



- (51) **International Patent Classification:**
A24F 47/00 (2006.01) *A61M 15/00* (2006.01)
- (21) **International Application Number:**
PCT/EP2011/057797
- (22) **International Filing Date:**
13 May 2011 (13.05.2011)
- (25) **Filing Language:** English
- (26) **Publication Language:** English
- (30) **Priority Data:**
12/787,258 25 May 2010 (25.05.2010) US
- (71) **Applicant (for all designated States except US):**
BRITISH AMERICAN TOBACCO (INVESTMENTS) LIMITED [GB/GB]; Globe House, 1 Water Street, London WC2R 3LA (GB).
- (72) **Inventor; and**
- (75) **Inventor/Applicant (for US only):** **SCHENNUM, Steven, Michael** [US/US]; 15154 Eyre Circle, Plainfield, IL 60544 (US).
- (74) **Agents:** **READ, Matthew** et al.; 20 Little Britain, London EC1A 7DH (GB).

- (81) **Designated States (unless otherwise indicated, for every kind of national protection available):** AE, AG, AL, AM, AO, AT, AU, AZ, BA, BB, BG, BH, BR, BW, BY, BZ, CA, CH, CL, CN, CO, CR, CU, CZ, DE, DK, DM, DO, DZ, EC, EE, EG, ES, FI, GB, GD, GE, GH, GM, GT, HN, HR, HU, ID, IL, IN, IS, JP, KE, KG, KM, KN, KP, KR, KZ, LA, LC, LK, LR, LS, LT, LU, LY, MA, MD, ME, MG, MK, MN, MW, MX, MY, MZ, NA, NG, NI, NO, NZ, OM, PE, PG, PH, PL, PT, RO, RS, RU, SC, SD, SE, SG, SK, SL, SM, ST, SV, SY, TH, TJ, TM, TN, TR, TT, TZ, UA, UG, US, UZ, VC, VN, ZA, ZM, ZW.
- (84) **Designated States (unless otherwise indicated, for every kind of regional protection available):** ARIPO (BW, GH, GM, KE, LR, LS, MW, MZ, NA, SD, SL, SZ, TZ, UG, ZM, ZW), Eurasian (AM, AZ, BY, KG, KZ, MD, RU, TJ, TM), European (AL, AT, BE, BG, CH, CY, CZ, DE, DK, EE, ES, FI, FR, GB, GR, HR, HU, IE, IS, IT, LT, LU, LV, MC, MK, MT, NL, NO, PL, PT, RO, RS, SE, SI, SK, SM, TR), OAPI (BF, BJ, CF, CG, CI, CM, GA, GN, GQ, GW, ML, MR, NE, SN, TD, TG).

Published:

— with international search report (Art. 21(3))

(54) **Title:** AEROSOL GENERATOR

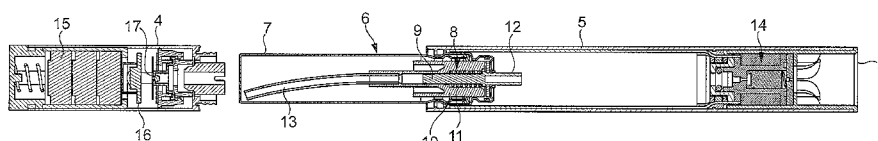

FIG. 5

(57) **Abstract:** An aerosol generator (1) has a generally cylindrical body with a mouthpiece at one end a canister (6) removably received within the body, the canister containing pressurised fluid, an interior, continuous canister valve (8) and a depressible discharge tube (12) that releases the fluid into the body. An electrically operable valve (14) controls the discharge of the fluid from the canister towards the mouthpiece, and a nozzle forms an aerosol of the fluid that discharges from the canister. A pressure switch (17) switches in response to a pressure reduction at the mouthpiece and supplies electrical power from internal batteries (15) to the valve to produce a discharge of the fluid through the valve to create an aerosol in the mouthpiece for the consumer.



WO 2011/147699 A1

Aerosol generator

Field of the invention

This invention relates to a portable, aerosol generator which may be hand held and
5 used to deliver aerosol to the mouth of a consumer, for example, but not exclusively
an aerosol containing nicotine.

Background

A nicotine dispensing aerosol device is disclosed in US 4,945,929, which simulates a
10 smoking article such as a cigarette, without having to burn tobacco.

Summary of the invention

The invention provides an aerosol generator that is electrically actuated by means of
a pressure switch and a valve. In an embodiment of the invention the aerosol device
15 has a body with a mouthpiece, the body being configured to receive a supply of
pressurised fluid to be discharged towards the mouthpiece as an aerosol, and an
electrically operable valve is provided to control the discharge of the fluid towards
the mouthpiece. The pressure switch is configured to switch electrical power to the
valve to produce a discharge of the fluid through the valve in response to a pressure
20 reduction at the mouthpiece.

Brief description of the drawings

In order that the invention may be more fully understood, an embodiment thereof
will now be described by way of illustrative example with reference to the
25 accompanying drawings in which:

Figure 1 is a side view of an aerosol generator;

Figure 2 is a mouth end view of the generator shown in Figure 1;

Figure 3 illustrates the aerosol generator when hand held for use by a consumer;

Figure 4 is a schematic illustration of the major components of the generator when
30 partially disassembled;

Figure 5 is a longitudinal sectional view of the generator when partially
disassembled;

Figure 6 is a longitudinal sectional view of the generator corresponding to Figure 5, when fully assembled;

Figure 7 is an exploded perspective view of the generator with the components at its proximal, mouth end shown in more detail;

5 Figure 8 is an exploded perspective view of the generator with the components intermediate the proximal and distal ends shown in more detail;

Figure 9 is an exploded perspective view of the generator with the components at its distal end shown in more detail;

10 Figure 10 is a schematic circuit diagram of the electrical components of the aerosol generator;

Figure 11a is an enlarged partial sectional view of the proximal, mouth end, showing the solenoid actuated valve for creating the aerosol, when closed;

Figure 11b corresponds to the view of Figure 11a but showing the solenoid actuated valve driven open to create the aerosol;

15 Figure 12 is an enlarged, broken away view of the distal end illustrating the puff actuated pressure switch in more detail;

Figure 13 an enlarged, broken away view of components in a region between the proximal and distal ends, illustrating a pressure communication passageway to the pressure switch;

20 Figures 14a and 14b illustrate the pressure switch in its inoperative and operative states respectively;

Figure 15 is a further broken away view of the mouth end showing the pressure communication passageway extending around the solenoid operated valve;

25 Figure 16 illustrates the interior arrangement of the solenoid operated valve within the mouth end shells and showing the pressure communication passageway extending around the solenoid operated valve; and

Figure 17 is a perspective view of the battery compartment.

Detailed description

Overview

An aerosol generator 1 is illustrated in Figures 1 and 2, which is generally cylindrical and may be held between the fingers of a consumer's hand as illustrated in Figure 3, to simulate a smoking article such as a cigarette. The generator 1 has a proximal, mouth end 2 and a distal end 3, and delivers an aerosol to the mouth end 2. The aerosol may contain nicotine.

Referring to Figure 4, the cylindrical body of the generator comprises a distal end housing 4 that contains batteries, control circuit and a pressure actuated switch to be described in more detail later. The distal end housing 4 is releasably attached coaxially to a cylindrical main housing 5. A canister 6 containing pressurised fluid for forming an aerosol is fitted into the main housing 5 and retained in place by the distal end housing 4.

The structure of the aerosol generator 1 will now be described in detail with reference to Figures 5 to 9. As shown in Figures 5 and 6, the canister 6 comprises a generally cylindrical body 7 and an integral valve 8 which includes a valve stem 9 slidably mounted in a valve seat 10, biased to be normally closed by spring 11. The valve stem 9 has an axial discharge tube 12 through which pressurised liquid from within the container is discharged when depressed axially inwardly of the canister, the liquid being fed through inlet tube 13 from within the canister 6 to the valve 8. The valve 8 is a so-called continuous valve, which, when the valve stem 9 is pushed inwardly to open the valve, discharges fluid from the canister continuously until empty or until the valve stem is released to close the valve.

Canister 6 can be interchanged by removal of the distal end housing 4 as can be seen from Figures 4, 5 and 6. The canister 6 may be charged with a nicotine containing liquid and propellant such as HFA although other flavourants and propellants may be used.

When the canister 6 is installed as shown in Figure 6, it is driven against a solenoid operated valve 14. When installed, the discharge tube 12 is pressed axially inwardly of the canister 6 to open the valve 8 against the force of its interior spring 11 so
5 that the discharge of liquid from the canister is controlled by the solenoid operated valve 14.

As shown in Figures 5 and 6, the distal end housing 4 contains batteries 15 which provide electrical power to circuitry on a printed circuit board (PCB) 16, which
10 controls the supply of the electrical power to the solenoid operated valve 14 in response to actuation of a pressure switch 17 that is responsive to changes in pressure in the mouthpiece 2.

Figure 10 illustrates the electrical circuitry of the aerosol generator schematically.
15 The batteries 15 are coupled to the control circuitry on printed circuit board 16 and electrical power is fed from the control circuitry to the solenoid operated valve 14 under the control of the pressure actuated switch 17. The control circuitry 16 may comprise an integrated circuit digital processor or may comprise an analog circuit. The circuitry 16 is responsive to operation of the pressure switch 17 to supply
20 power from the battery 15 to the solenoid operated valve 14 for a predetermined period so as to generate a puff of aerosol from liquid discharged from the canister 6. The switch 17 is actuated by the user drawing on the mouthpiece 2 and the pressure reduction is communicated along the cylindrical housing 5 to the switch 17 through passageways to be described in more detail hereinafter.

25

The control circuitry 16 may be configured so that once a first puff has been taken by the consumer, the solenoid operated valve 14 is inhibited from producing a further puff for a predetermined period of time. The control circuitry 16 may perform other functions and for example may include a battery sensor that indicates
30 when the batteries are becoming discharged, to operate a light emitting diode 18 or similar indicator illustrated in Figure 10 (not illustrated elsewhere in the drawings).

Also, it will be understood that whilst the device shown in the drawings utilises three button cell batteries 15, other battery configurations may be utilised, including rechargeable batteries.

5 **Solenoid operated valve**

The construction and operation of the solenoid operated valve 14 will now be described in more detail with reference to Figures 7 and 11. The valve 14 includes a solenoid body 19 in the form of a bobbin that receives a solenoid coil 20. Wires 21a, 21b run along the interior of the cylindrical housing 5 for supplying electrical
10 power to the solenoid coil 20.

The bobbin 19 includes a longitudinal passageway comprising a central bore 19a that receives a valve member comprising a solenoid plunger 22 biased by spring 23 against a valve seat 24. The plunger 22 is slidably received in the bore 19a with a
15 small clearance to allow the passage of fluid through the bore 19a from the canister around the plunger when the valve is open, as will be explained in more detail later. A valve seal 25 is fixed to the plunger 22 to seal against the valve seat 24 when the valve 14 is closed. The bobbin 19 includes at its distal end a stepped bore 26 which receives the discharge tube 12 of the canister 6. A gasket seal 27 is disposed
20 between the end of the discharge tube 12 and the stepped bore 26 to provide a seal. Additionally, an O-ring 28 is configured around the discharge tube 12 and is retained by a circular valve inlet member 29. The stepped bore 26 extends into an inlet bore 30, which is normally closed by the solenoid plunger 22 and seal 25.

25 The valve 14 also includes a nozzle outlet 31 in the form of a circular plate which is sealed against the proximal end of the bobbin 19 by a circular outlet gasket 32. The nozzle outlet 31 includes an axial outlet orifice 33 to discharge aerosol into the mouthpiece 2.

30 The solenoid valve and nozzle assembly is received within generally cylindrical housing shells 34a, 34b which when assembled together can be slide as a tubular

unit into the housing 5 from the proximal, mouthpiece end 2. The housing shells 34a, b include fins 35 for structural support.

When the canister 6 is installed in the housing 5, it is pressed against the bobbin 19
5 and gasket seal 27 so that the discharge tube 12 of the canister is pressed inwardly
against force of spring 11 with the result that fluid under pressure is applied from
the canister 6 against the valve seat 24. When the valve 14 is unenergised as
illustrated in Figure 11a, the solenoid plunger 22 is driven by spring 23 against the
valve seat 24 to close the valve and the seals 25, 27 and 28 ensure that no fluid
10 leakage occurs.

When the solenoid valve 14 is actuated, the magnetic field produced by the coil 20
urges the solenoid plunger 22 towards the proximal end 2 as illustrated in Figure
11b, against the force of the spring 23, so as to open the valve and produce a
15 spacing 36 between the distal end of the solenoid plunger 22 and seal 25, and the
valve seat 24. Fluid from the canister 6 can then pass through the discharge tube 12
and the inlet orifice 30, so as to pass through the gap between the cylindrical outer
surface of the solenoid plunger 22 and the central bore 19a of bobbin 19, to the
orifice 33 in the nozzle outlet 31. As a result, an aerosol spray illustrated by dotted
20 lines 37 is directed to the mouthpiece 2.

Pressure sensitive switch

Referring to Figures 8, 12, 13 and 14, the pressure sensitive switch 17 is located
between the canister 6 and the batteries 15. The switch 17 comprises a pair of
25 semicircular switch contacts 36a, 36b (also shown in Figure 10) which are spaced
apart and each electrically connected to the control circuit on PCB 16. The
switching contacts 36a, 36b are bridged selectively by a movable, electrically
conductive bridge contact 37 which has a location lug 38 received in an axial
extension 39 of a resilient diaphragm 40 sandwiched between a proximal and distal
30 annular switch supports 41, 42. As shown in Figure 13, the pressure switch
assembly abuts an annular spacer member 43 that comprises the proximal end of

the distal housing 4, which provides an end stop against the canister 6 when assembled.

The spacer member 43 includes an axial passageway 43a provided with radially
5 extending slots 44. The main housing 5 includes ribs 45 that provide locating
points for the canister 6 along its length so that an air passageway is provided
around the canister extending from the radial slots 44 towards the mouthpiece 2.

When the consumer puffs on the mouthpiece 2, a pressure reduction occurs so that
10 air travels in the direction of arrows A, producing a pressure differential across the
diaphragm 40. As a result, the lug 39 on the diaphragm is moved axially towards
the mouthpiece 2, pulling the bridge contact 37 into electrical connection with the
switch contacts 36a, 36b. The contacts 36a, 36b are electrically connected to the
control circuitry on PCB 16, which detects the electrical bridging of the contacts
15 and in response, feeds a drive current to the solenoid operated valve 14 through
conductors 21a, 21b and additional wires (not shown). As previously explained, the
control circuit may operate the solenoid 14 for a predetermined time to achieve a
particular duration of puff. Alternatively, the circuitry 16 may operate the solenoid
for the duration that the consumer lowers pressure in the mouthpiece 2, so as to
20 provide a continuous production whilst the consumer draws on the mouthpiece 2.

Thus, the negative pressure produced by the consumer results in the bridging
contact 37 moving from the position shown in Figure 14a spaced by a distance 46
from the contacts 36a, 36b, to the position shown in Figure 14b in which the
25 bridging contact 37 touches the switch contacts 36a, 36b.

Referring to Figures 15 and 16, a passageway is provided in the annular space
between the canister 6 and main housing 5 to allow negative pressure in the
mouthpiece 2 to communicate with the pressure sensitive switch 17. To this end,
30 the shells 34a, 34b are provided with cutaway portions 47 to provide axially
extending passageways that allow air to flow in the direction of arrows A when the

consumer sucks on the mouthpiece 2. The volume of the passageway between the mouthpiece and the switch 17 is made sufficiently small that the negative pressure produced by sucking the mouthpiece is not degraded significantly.

5 **Battery Compartment**

Referring to Figures 5, 6, 9 and 17, the batteries 15 are received in a stack within a generally cylindrical battery holder 48 having a removable closure member 49. In this example, the closure member 49 is located by lugs 50 that are received in corresponding slots 51 to provide a bayonet mounting. The batteries 15 are located
10 by a spring 52 which provides an electrical connection to a distal battery contact 53 that has axially extending tongues 53a that engage with battery contact 54 fixed to the exterior of the battery holder 48. The contact 54 is electrically connected to battery wire 55 that is mounted axially along the battery holder 48 and provides an electrical connection to the circuitry on PCB 16. A proximal battery contact 56 is
15 provided which, as shown clearly in Figure 13, is electrically connected to the proximal end of the stack of batteries 15. The proximal battery contact 56 is mounted directly on the PCB 16. A contact 57 also directly mounted on the PCB 16 provides an electrical connection between a proximal end of battery wire 55 and PCB 16.

20

As illustrated in Figure 12, the assembled battery compartment is push-fitted into the distal end housing 4 along with the pressure switch 17 so as to abut an interior, annular step 42a in the housing 4.

25 Figure 17 illustrates the distal end of the aerosol generator with the distal end of the housing 4 removed. The electrical conductors 21a, 21b that extend from the solenoid operated valve 17 terminate in distal end contacts 58a, 58b mounted within the distal end of the main housing 5. The contacts 58a, 58b electrically connect to contacts 59a, 59b mounted in the proximal end of the distal housing 4, within its
30 end piece 42 and are so configured that when the distal end housing 4 is screwed into place on the main housing 5, the contacts 58a, 58b mate with the contacts 59a,

59b respectively. The contacts 59 are each electrically connected to the PCB 16 by connecting wires (not shown) although it will be appreciated that metallisation contacts may be formed on the interior of the housing 4, if desired, instead of separate wiring.

5

Operation

In use, a consumer draws on the mouthpiece 2 in order to reduce the ambient pressure in the mouthpiece, which draws air from the vicinity of the pressure switch 17 in the direction of arrows A, causing the pressure switch to move from the position shown in Figure 14a to that shown in Figure 14b. As a result, the control circuitry on PCB 16 shown in Figure 10 energises the solenoid operated valve 14 to release a puff of aerosol to the consumer through the mouthpiece.

Many modifications and variations will be evident to those skilled in the art. For example, the canister 6 may be provided with an alignment mechanism to arrange the inlet tube 13 to be configured downwardly in normal use to ensure that the entire contents of the canister 6 can be consumed. For example, the supply tube of the pressurised canister may be of flexible construction and provided with a weighted end as to always assume the lowest position in the canister orientation and allow for complete consumption of the canister contents.

20

Furthermore, the circuitry on PCB 16 may include an LED to indicate when the pressure switch 17 is actuated. Many other modifications and variations falling within the scope of the claims will be evident to those skilled in the art.

Also whilst the described examples of generator device are generally cylindrical with a circular cross section, other cross sectional shapes can be used, such as rectangular or triangular.

Furthermore, although the canister is described as an interchangeable element to allow the supply of liquid to be replenished, an integral pressurised supply vessel may be provided in the device, so that the device can be used multiple times and then discarded once the liquid supply has been exhausted from the vessel. In a

30

modification, an inlet valve may be provided to allow the supply to be replenished from an exterior, pressurised source.

The mouth end can be configured differently from that shown in the Figures. For example the mouth end could be a tapered cylindrical shape with flat piece for easy
5 positioning and orientation cue in the mouth. Also, textured or rough finishes can be applied to the exterior surface of the mouthpiece to stimulate sensation in the lips.

Also, it will be appreciated that the device may include alternative electrical power
10 sources to the batteries described with reference to the drawings, for example rechargeable batteries or a portable fuel cell.

Claims

1. An aerosol generator comprising a body having a mouthpiece, the body being configured to receive a supply of pressurised fluid to be discharged towards
5 the mouthpiece as an aerosol, an electrically operable valve to control the discharge of the fluid towards the mouthpiece, and a pressure switch configured to switch electrical power to the valve to produce a discharge of the fluid through the valve in response to a pressure reduction at the mouthpiece.
- 10 2. A generator as claimed in claim 1 including a nozzle to form the aerosol from the fluid discharged from the valve.
3. A generator as claimed in claim 1 wherein the body is elongate and configured to be held between the fingers of a hand.
- 15 4. A generator as claimed in claim 1 wherein the body includes a compartment to receive a supply of the pressurised fluid.
5. A generator as claimed in claim 4 wherein the compartment comprises a
20 canister compartment that is configured to receive a canister containing the pressurised fluid with an interior canister valve and a depressible discharge tube that releases the fluid into the body, canister compartment being configured to hold the interior canister valve open when fitted into the body.
- 25 6. A generator as claimed in claim 5 and including the canister.
7. A generator as claimed in claim 1 wherein the body includes a battery compartment to receive a battery to power the valve.
- 30 8. A generator as claimed in claim 1 including a generally cylindrical main body housing and a distal end housing releasably attached to and coaxial with the main body housing.

9. A generator as claimed in claim 8 including a battery compartment and the pressure switch in the distal end housing.
10. A generator as claimed in claim 1 wherein the pressure switch includes a
5 diaphragm moveable in response to said pressure reduction at the mouthpiece, and an electrically conductive switch contact moved by the diaphragm in response to the pressure reduction.
11. A generator as claimed in claim 1 including electrical circuitry responsive to
10 operation of the pressure switch to supply electrical power to the valve.
12. A generator as claimed in claim 11 wherein the circuitry is operable to supply the electrical power to the valve for a predetermined time following actuation of the pressure switch.
15
13. A generator as claimed in claim 11 wherein the circuitry is operable to inhibit supply of the electrical power to the valve for a predetermined time following operation of the switch.
- 20 14. A generator as claimed in claim 1 wherein the electrically operable valve comprises a solenoid operated valve.
15. A generator as claimed in claim 14 wherein the valve includes a bobbin with a longitudinal passageway therein, a valve seat in the passageway, an inlet to supply
25 the fluid to the passageway, a valve member moveable in the passageway to engage the valve seat, and an electrical coil to be energised for moving the valve member to open and close the valve.
16. An aerosol generator comprising:
30 a generally cylindrical body having a mouthpiece and a canister compartment,

a canister removably received within the canister compartment, the canister containing pressurised fluid, an interior canister valve and a depressible discharge tube that releases the fluid into the body,

the canister compartment being configured to hold the interior canister valve
5 open,

an electrically operable valve to control the discharge of the fluid from the canister towards the mouthpiece,

a nozzle to form an aerosol of the fluid that discharges from the canister,
and

10 a pressure switch configured to switch electrical power to the valve to produce a discharge of the fluid through the valve in response to a pressure reduction at the mouthpiece.

17. A generator as claimed in claim 16 including a battery compartment at an
15 end of the housing distal from the mouthpiece, the pressure switch being located between the canister and the battery compartment.

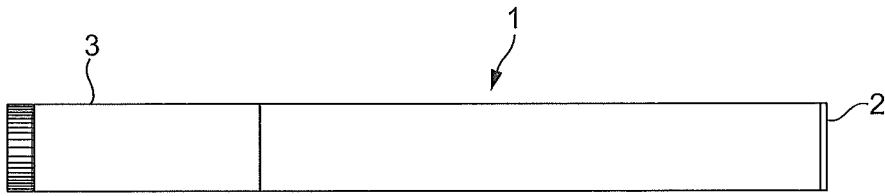

FIG. 1

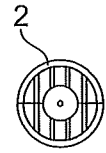

FIG. 2

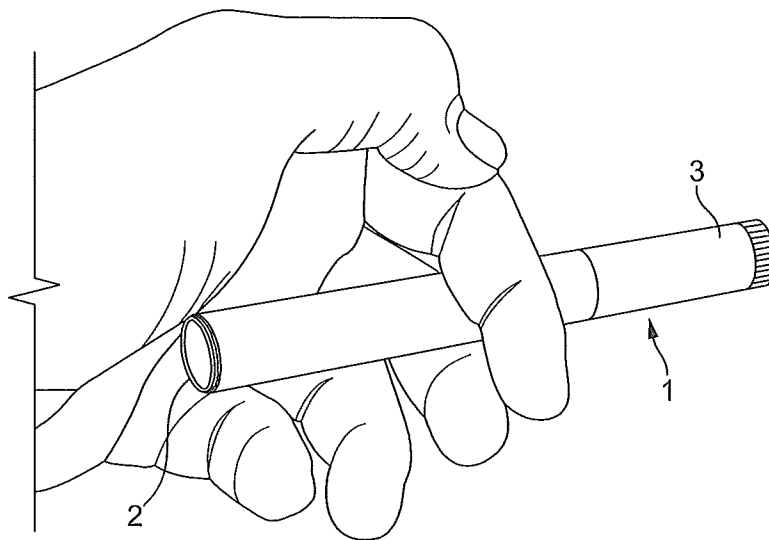

FIG. 3

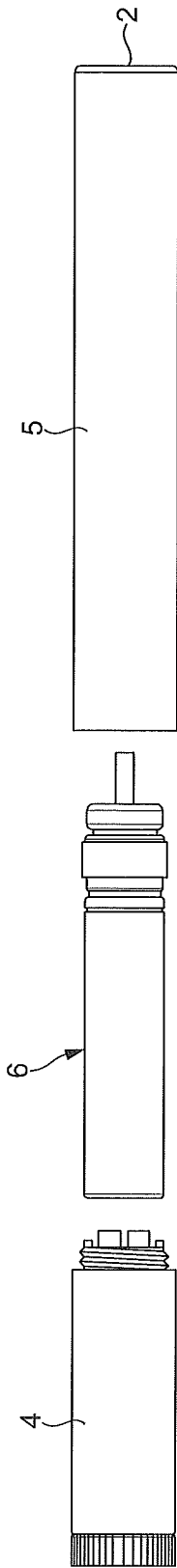

FIG. 4

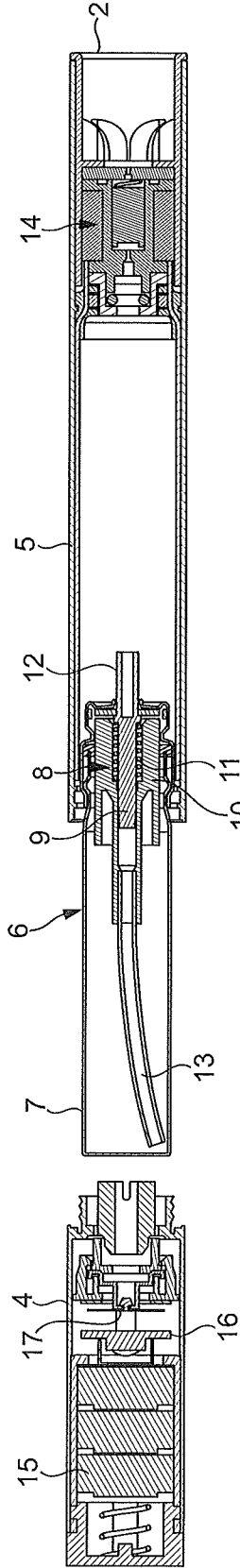

FIG. 5

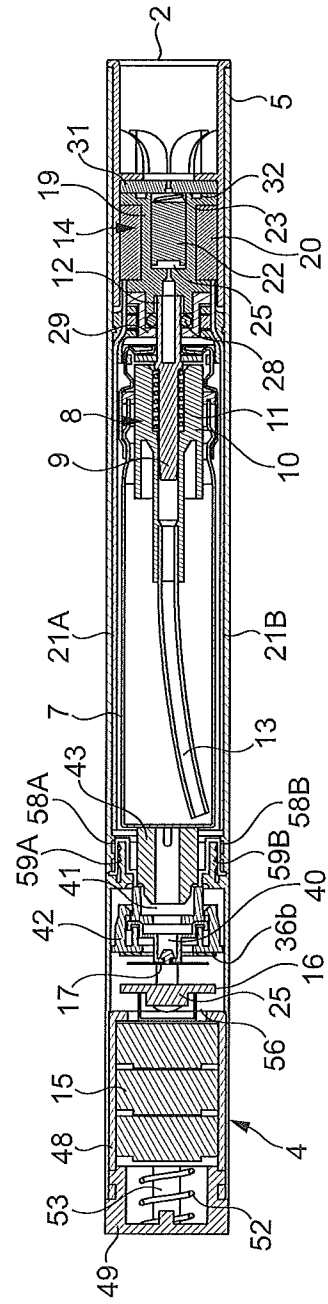

FIG. 6

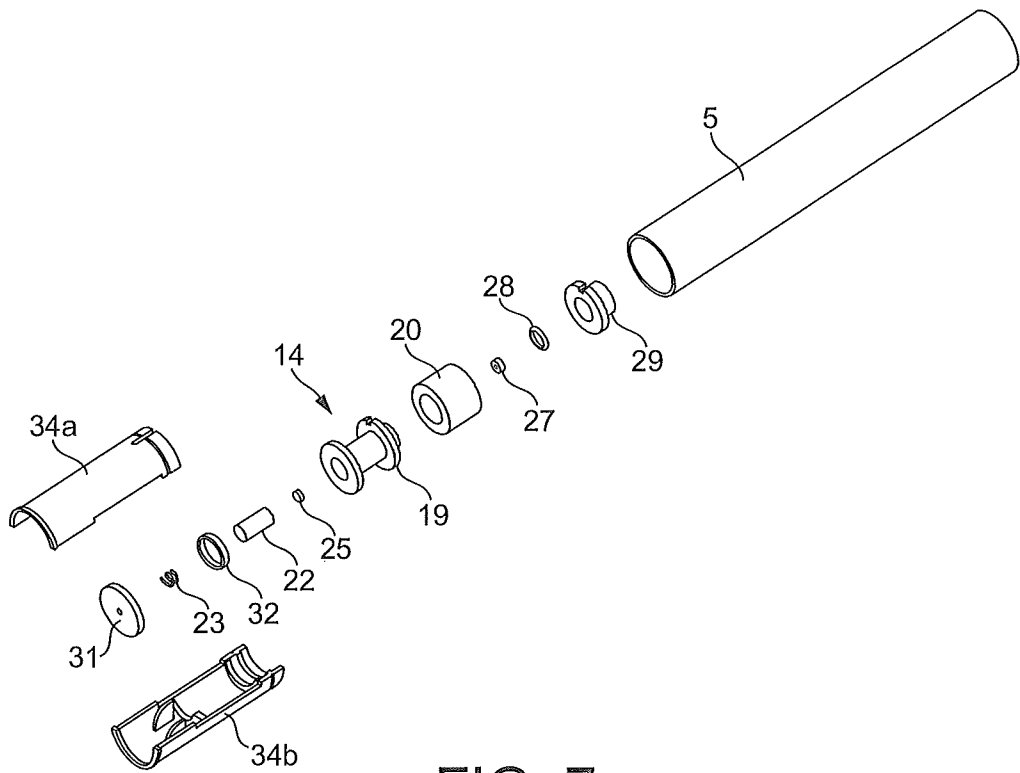

FIG. 7

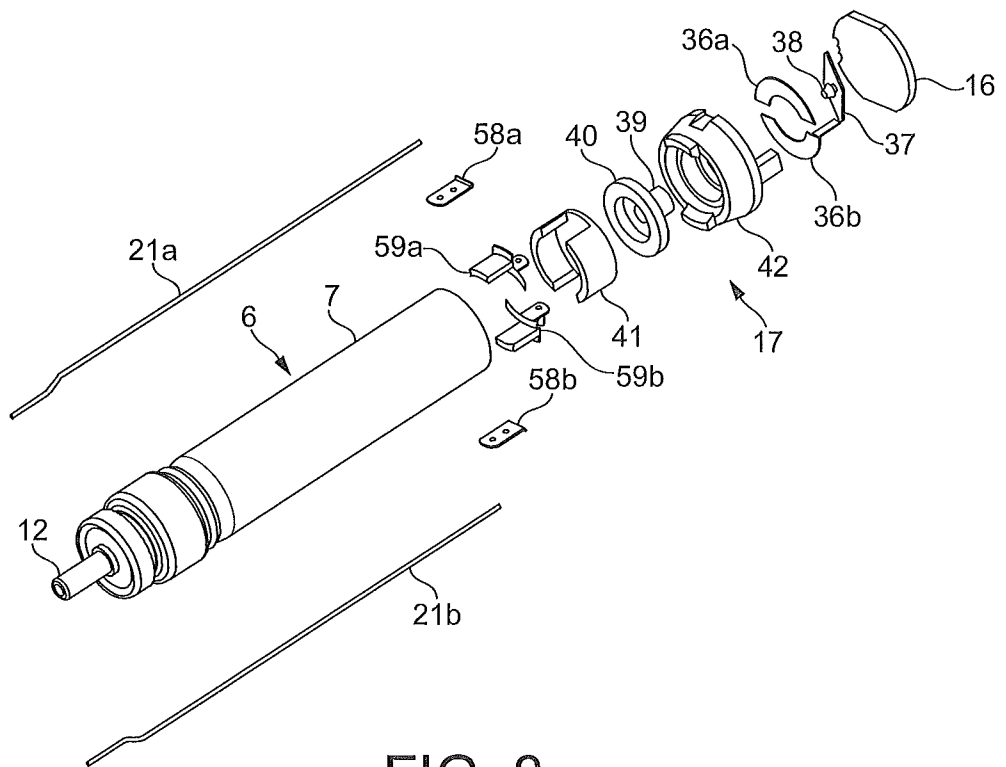

FIG. 8

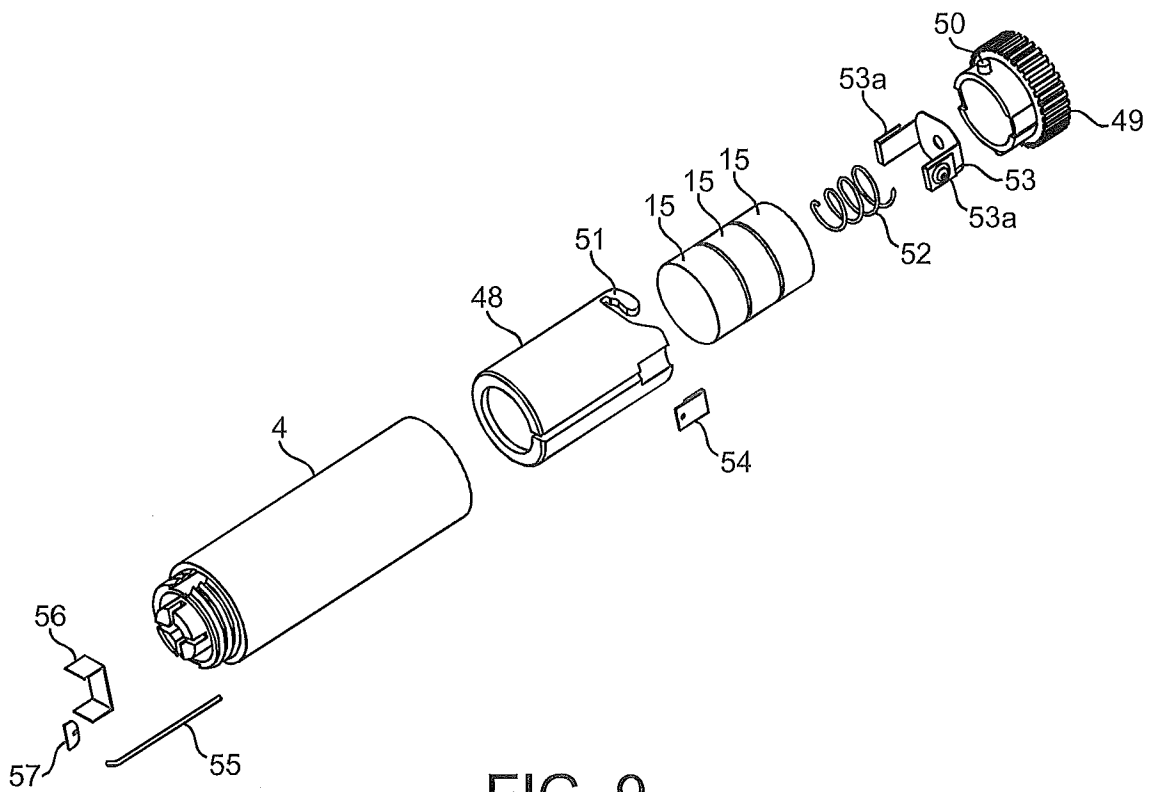

FIG. 9

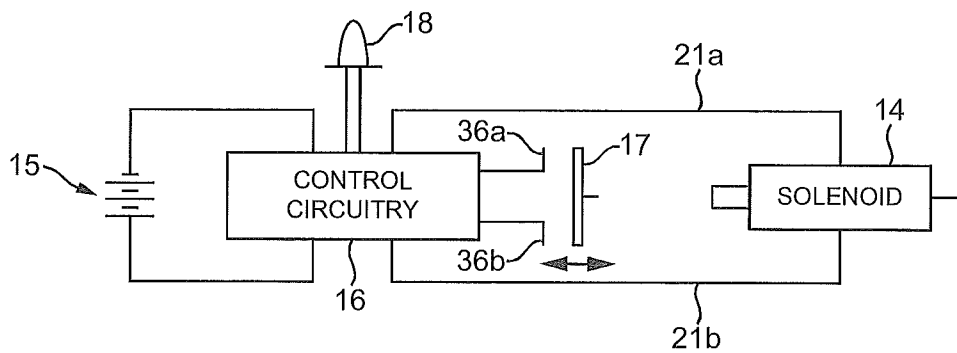

FIG. 10

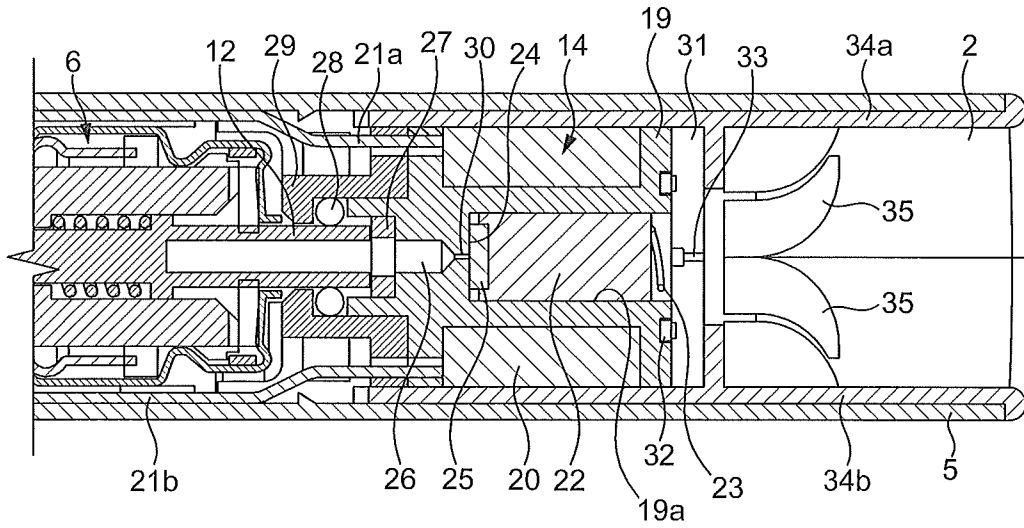

FIG. 11a

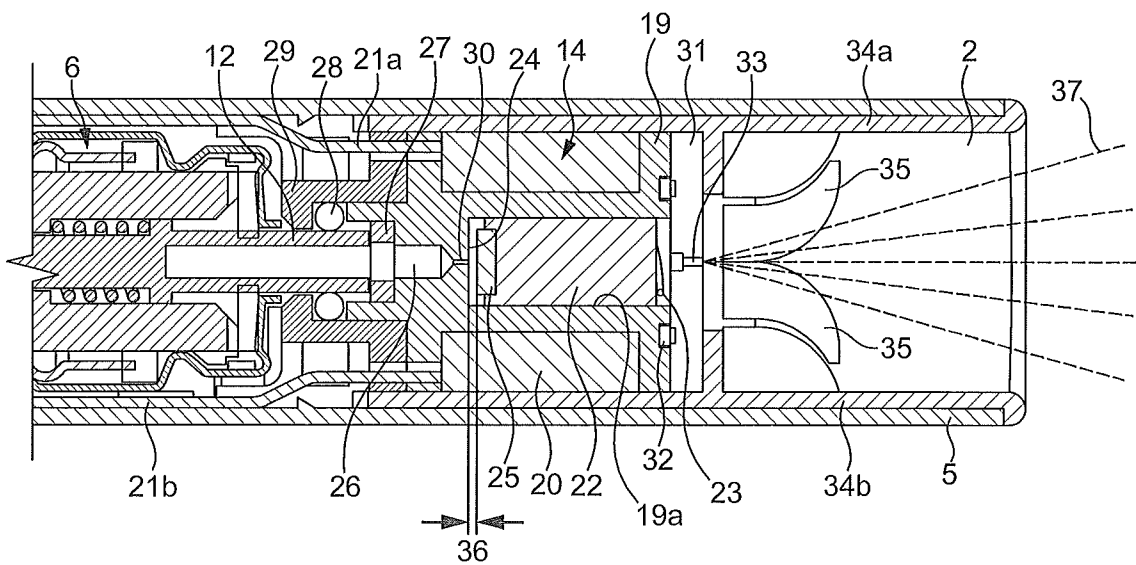

FIG. 11b

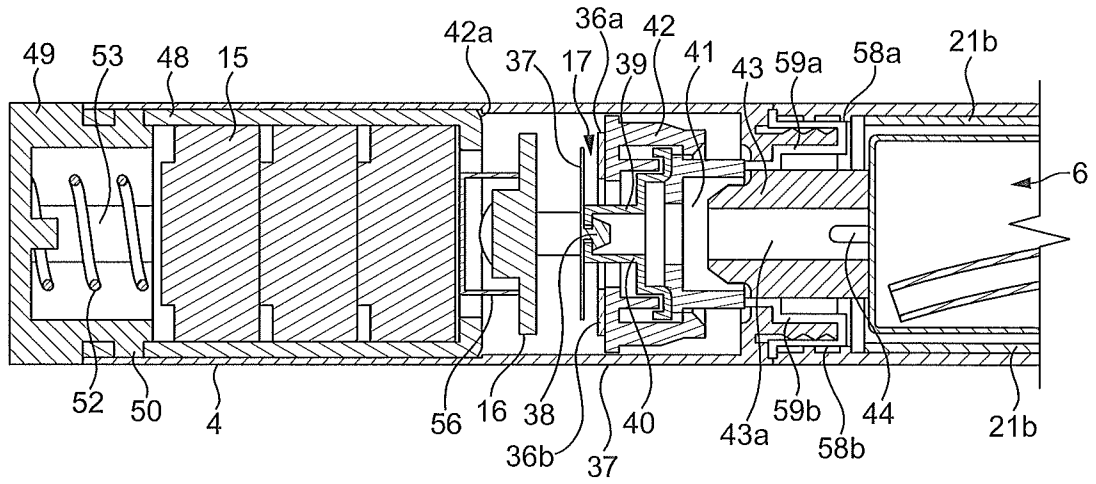

FIG. 12

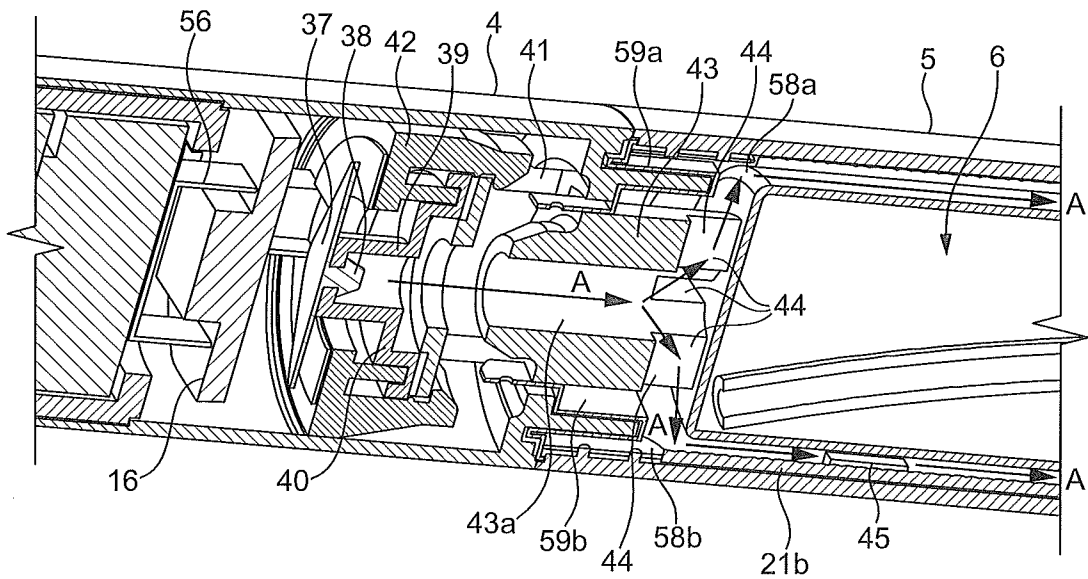

FIG. 13

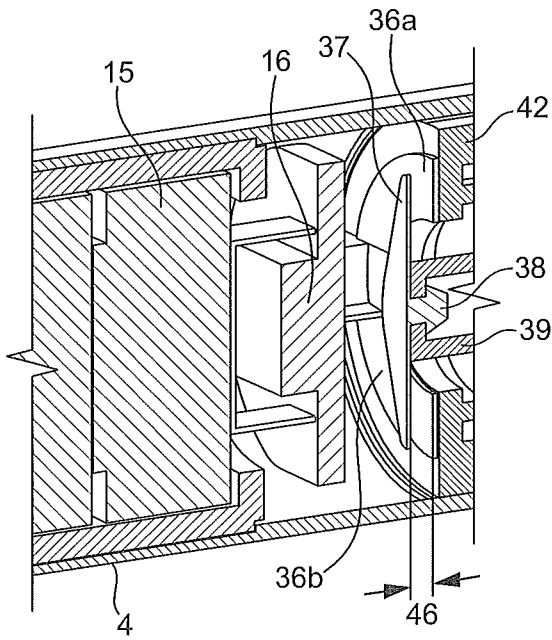

FIG. 14a

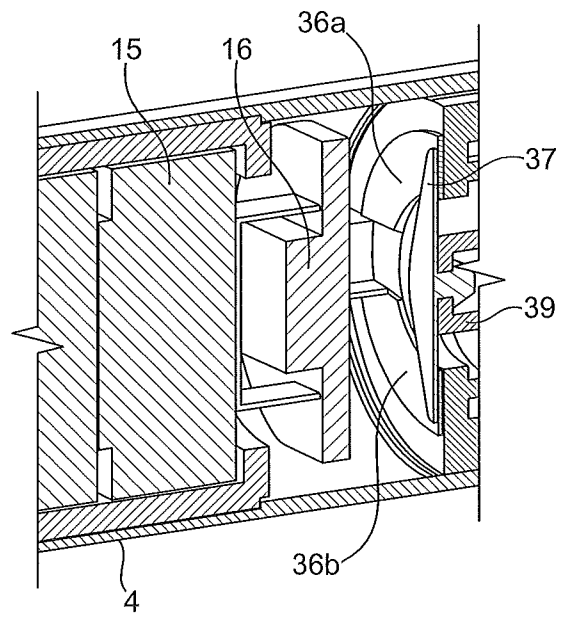

FIG. 14b

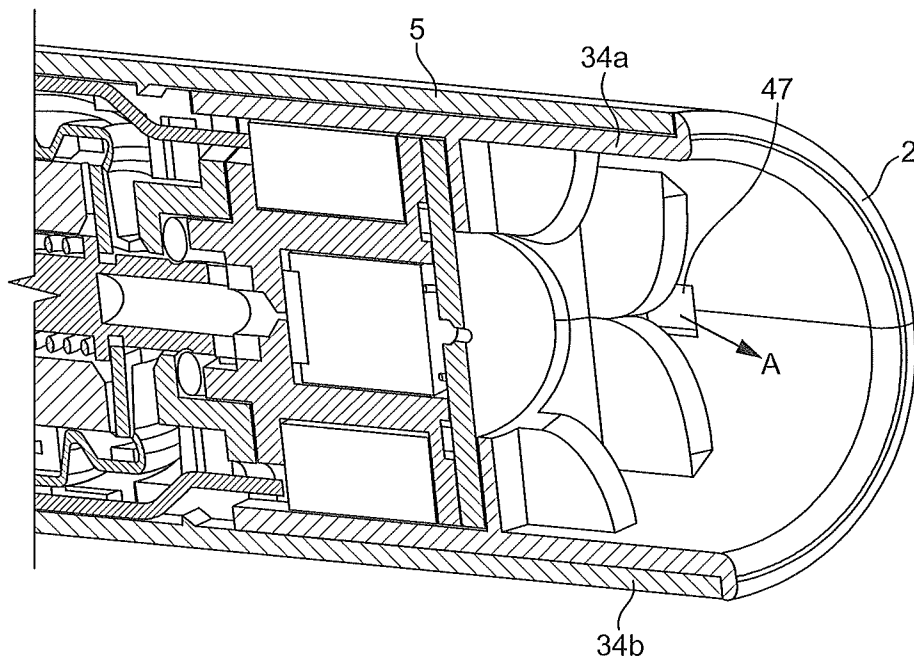

FIG. 15

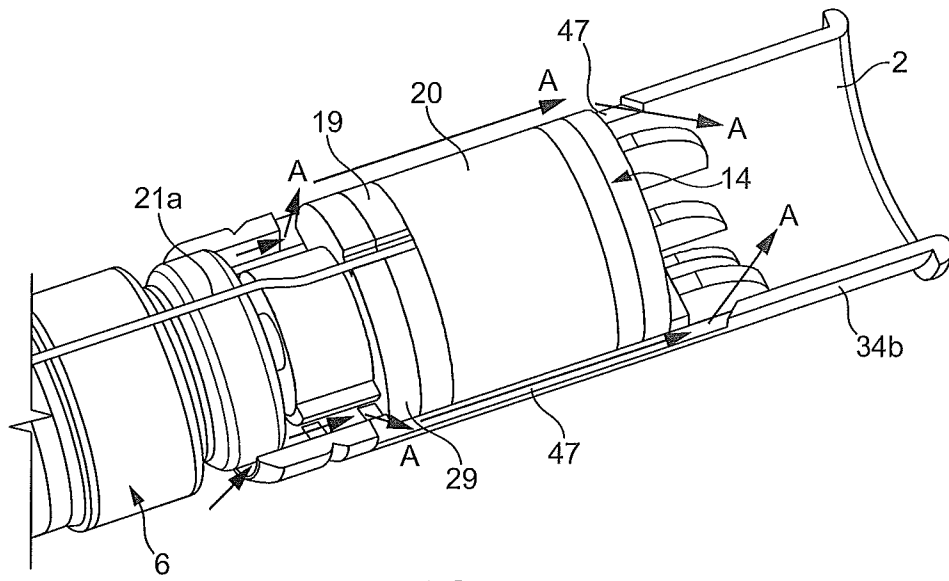

FIG. 16

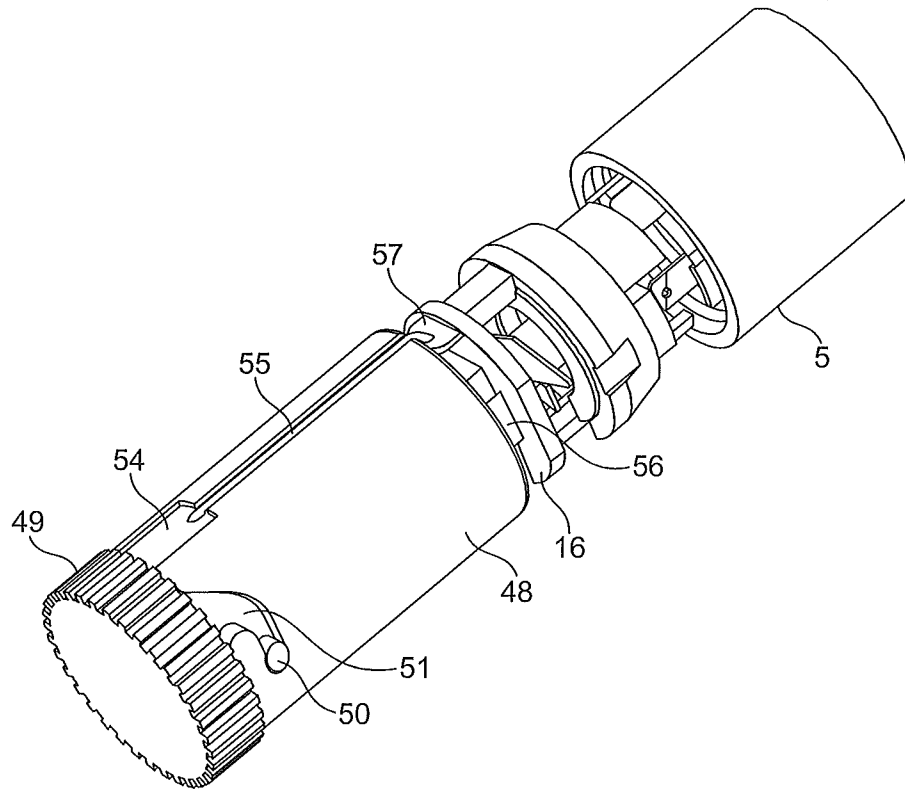

FIG. 17

INTERNATIONAL SEARCH REPORT

International application No
PCT/EP2011/057797

A. CLASSIFICATION OF SUBJECT MATTER
INV. A24F47/00 A61M15/00
ADD.
According to International Patent Classification (IPC) or to both national classification and IPC

B. FIELDS SEARCHED
Minimum documentation searched (classification system followed by classification symbols)
A24F A61M
Documentation searched other than minimum documentation to the extent that such documents are included in the fields searched

Electronic data base consulted during the international search (name of data base and, where practical, search terms used)
EPO-Internal

C. DOCUMENTS CONSIDERED TO BE RELEVANT		
Category*	Citation of document, with indication, where appropriate, of the relevant passages	Relevant to claim No.
X	GB 2 266 466 A (BESPAK PLC [GB]) 3 November 1993 (1993-11-03) page 3, line 2 - page 5, line 31; figures 1-3	1-17
X	----- WO 02/100469 A2 (GLAXO GROUP LTD [GB]; WALKER RICHARD IAN [GB]; BEAUMONT GARY ROBERT [G] 19 December 2002 (2002-12-19) page 3, line 26 - page 29, line 28; figures	1-17
X	----- WO 00/53247 A1 (GLAXO GROUP LTD [GB]; JONES ANTHONY PATRICK [GB]; ANDERSON GREGOR JOHN) 14 September 2000 (2000-09-14) page 2, line 34 - page 7, line 2; figures ----- -/--	1-17

Further documents are listed in the continuation of Box C.

See patent family annex.

* Special categories of cited documents :

<p>"A" document defining the general state of the art which is not considered to be of particular relevance</p> <p>"E" earlier document but published on or after the international filing date</p> <p>"L" document which may throw doubts on priority claim(s) or which is cited to establish the publication date of another citation or other special reason (as specified)</p> <p>"O" document referring to an oral disclosure, use, exhibition or other means</p> <p>"P" document published prior to the international filing date but later than the priority date claimed</p>	<p>"T" later document published after the international filing date or priority date and not in conflict with the application but cited to understand the principle or theory underlying the invention</p> <p>"X" document of particular relevance; the claimed invention cannot be considered novel or cannot be considered to involve an inventive step when the document is taken alone</p> <p>"Y" document of particular relevance; the claimed invention cannot be considered to involve an inventive step when the document is combined with one or more other such documents, such combination being obvious to a person skilled in the art.</p> <p>"&" document member of the same patent family</p>
--	--

Date of the actual completion of the international search 27 July 2011	Date of mailing of the international search report 04/08/2011
---	--

Name and mailing address of the ISA/ European Patent Office, P.B. 5818 Patentlaan 2 NL - 2280 HV Rijswijk Tel. (+31-70) 340-2040, Fax: (+31-70) 340-3016	Authorized officer Marzano Monterosso
--	--

INTERNATIONAL SEARCH REPORT

International application No
PCT/EP2011/057797

C(Continuation). DOCUMENTS CONSIDERED TO BE RELEVANT		
Category*	Citation of document, with indication, where appropriate, of the relevant passages	Relevant to claim No.
X	US 4 393 884 A (JACOBS ALLEN W [US]) 19 July 1983 (1983-07-19) page 2, line 56 - line 61 -----	1-4,16
X	WO 00/12162 A1 (GLAXO GROUP LTD [GB]; BONNEY STANLEY GEORGE [GB]; JONES ANTHONY PATRIC) 9 March 2000 (2000-03-09) the whole document -----	1-4,16
X,P	WO 2011/015825 A1 (KIND CONSUMER LTD [GB]; HEARN ALEX [GB]; MCDERMENT IAIN [GB]) 10 February 2011 (2011-02-10) the whole document -----	1-17
A	WO 2009/135729 A1 (BRITISH AMERICAN TOBACCO CO [GB]; MURPHY JAMES [GB]) 12 November 2009 (2009-11-12) the whole document -----	1-17

INTERNATIONAL SEARCH REPORT

Information on patent family members

International application No
PCT/EP2011/057797

Patent document cited in search report	Publication date	Patent family member(s)	Publication date
GB 2266466	A	03-11-1993	NONE

WO 02100469	A2	19-12-2002	AT 331549 T 15-07-2006
		AU 2002345757 A1	23-12-2002
		DE 60212837 T2	21-06-2007
		EP 1395320 A2	10-03-2004
		JP 2004528151 A	16-09-2004
		US 2005022806 A1	03-02-2005

WO 0053247	A1	14-09-2000	AT 289209 T 15-03-2005
		AU 3158600 A	28-09-2000
		DE 60018170 D1	24-03-2005
		DE 60018170 T2	16-02-2006
		EP 1159020 A1	05-12-2001
		JP 2002537951 U	12-11-2002
		US 6990975 B1	31-01-2006

US 4393884	A	19-07-1983	NONE

WO 0012162	A1	09-03-2000	AT 309021 T 15-11-2005
		AU 5970899 A	21-03-2000
		DE 69928267 D1	15-12-2005
		DE 69928267 T2	08-06-2006
		EP 1107810 A1	20-06-2001
		JP 2002523190 A	30-07-2002
		US 6651651 B1	25-11-2003

WO 2011015825	A1	10-02-2011	GB 2476611 A 29-06-2011
		GB 2476612 A	29-06-2011
		WO 2011015826 A1	10-02-2011

WO 2009135729	A1	12-11-2009	AR 071683 A1 07-07-2010
		AU 2009243645 A1	12-11-2009
		CA 2722826 A1	12-11-2009
		CN 102014996 A	13-04-2011
		EP 2274035 A1	19-01-2011
		KR 20110003564 A	12-01-2011
		US 2011120455 A1	26-05-2011
