



US00D826027S

(12) **United States Design Patent**
Carey et al.

(10) **Patent No.:** **US D826,027 S**

(45) **Date of Patent:** **** Aug. 21, 2018**

(54) **LATCH**

3,782,765 A 1/1974 Wallyn
D232,798 S 9/1974 Roche
D237,135 S 10/1975 Wiant et al.

(71) Applicant: **THE METAL WARE CORPORATION**, Two Rivers, WI (US)

(Continued)

Primary Examiner — Prabhakar Deshmukh

(72) Inventors: **Richard Carey**, Manitowoc, WI (US);
Ross Niemi, Chicago, IL (US)

(74) *Attorney, Agent, or Firm* — Seager, Tufte & Wickhem LLP

(73) Assignee: **The Metal Ware Corporation**, Two Rivers, WI (US)

(57) **CLAIM**

(**) Term: **15 Years**

The ornamental design for a latch, as shown and described.

(21) Appl. No.: **29/608,071**

DESCRIPTION

(22) Filed: **Jun. 19, 2017**

(51) **LOC (11) Cl.** **08-07**

(52) **U.S. Cl.**

USPC **D8/331**; D8/339; D8/343

(58) **Field of Classification Search**

USPC D8/330, 331, 333, 339, 343, 344, 345,
D8/349, 354, 355, 356, 367, 382; 70/14,
70/49, 58, DIG. 63, DIG. 35, 30, 51, 52,
70/57, 57.1, 141, 431, 465, 466, 29,
70/63-76, 78, DIG. 31, DIG. 26, DIG. 67;
292/288, DIG. 30, 292, 181-287,
292/DIG. 16, DIG. 53, DIG. 42; 24/458,
24/455, 572.1, 573.09, 265 R, 307 R
CPC E05C 19/10; E05C 19/18; E05B 73/00;
B25G 3/00; B25G 3/12

See application file for complete search history.

(56) **References Cited**

U.S. PATENT DOCUMENTS

1,483,953 A 2/1924 Rainey
D70,542 S 7/1926 Davis et al.
1,699,313 A 1/1929 Schlaich
2,960,216 A 11/1960 Brady
3,350,902 A * 11/1967 Chance E05B 65/50
70/74
D210,795 S 4/1968 Birger et al.

FIG. 1 is a perspective view of a latch showing our new design;

FIG. 2 is a front elevational view thereof;

FIG. 3 is a rear elevational view thereof;

FIG. 4 is a right side elevational view thereof;

FIG. 5 is a left side elevational view thereof;

FIG. 6 is a top plan view thereof;

FIG. 7 is a bottom plan view thereof;

FIG. 8 is a perspective view thereof, shown the latch in environmental use with the latch in an engaged position;

FIG. 9 is a perspective view thereof, shown the latch in environmental use with the latch in a released position;

FIG. 10 is another perspective view thereof, shown the latch in environmental use with the latch in an engaged position;

FIG. 11 is another perspective view thereof, shown the latch in environmental use with the latch in an engaged position; FIG. 12 is another perspective view thereof, shown the latch in further environmental use with the latch in an engaged position; and,

FIG. 13 is another perspective view thereof, shown the latch in further environmental use with the latch in an engaged position.

The broken lines indicate the environment of a cooler in FIGS. 8-13 and form no part of the claimed design.

1 Claim, 13 Drawing Sheets

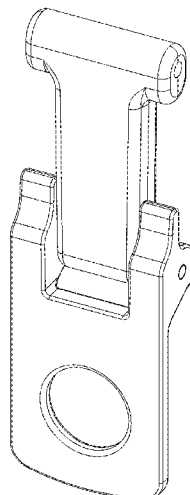

(56)

References Cited

U.S. PATENT DOCUMENTS

D257,934 S	1/1981	Buss	D467,770 S	12/2002	Blalock	
D259,232 S	5/1981	Tarozzi	D469,681 S *	2/2003	Votruba	D8/343
D266,822 S	11/1982	Seager	D475,248 S	6/2003	Cantor et al.	
D270,604 S	9/1983	Zauft	D486,457 S	2/2004	Leba et al.	
D281,695 S	12/1985	Ryan, Jr.	D492,184 S *	6/2004	Parker	D8/331
D283,480 S	4/1986	Bailey	D494,021 S	8/2004	Huthmaker	
D283,966 S	5/1986	Carlson	D511,247 S	11/2005	Tsuchiya	
D291,858 S	9/1987	Baker et al.	D511,624 S	11/2005	Rosine et al.	
4,702,504 A	10/1987	Brothers	D521,810 S	5/2006	Estes	
D305,397 S	1/1990	Balius	D528,368 S	9/2006	Maldonado	
D307,998 S	5/1990	Costello et al.	D541,627 S *	5/2007	Wolf	D8/331
D322,198 S	12/1991	Dringenburg	D552,426 S	10/2007	Jones et al.	
D325,323 S	4/1992	Kahl	D560,102 S	1/2008	Sumter	
D325,324 S	4/1992	Kahl	D563,731 S	3/2008	Thurston	
D325,853 S	5/1992	Kahl	D566,479 S	4/2008	Kabalin	
D328,221 S	7/1992	Piccarillo	D575,059 S	8/2008	Cappiello et al.	
D328,689 S	8/1992	Riskowski	7,424,813 B2 *	9/2008	Wu	E05B 37/0034 70/18
D330,329 S	10/1992	Brightbill	D587,972 S	3/2009	Dorisca et al.	
D333,775 S *	3/1993	Krape	7,533,782 B2	5/2009	Parker et al.	
D334,868 S	4/1993	Lau Woon	D595,185 S *	6/2009	Kouchi	D12/91
D340,167 S	10/1993	Kahl	7,540,364 B2	6/2009	Sanderson	
D340,620 S	10/1993	Peters	D604,994 S	12/2009	Greenlees	
D349,007 S	7/1994	Costello	D613,109 S	4/2010	Sanchez et al.	
D351,318 S	10/1994	Wedi	D613,560 S	4/2010	Robichaud et al.	
D352,208 S	11/1994	Brookshire	7,722,204 B1	5/2010	Sandberg	
D353,304 S	12/1994	Friedrich	7,810,220 B2 *	10/2010	Anthony	A01K 27/005 24/599.1
D354,419 S	1/1995	Kahl et al.	D634,982 S	3/2011	Melchert et al.	
D366,599 S	1/1996	Brown et al.	D637,459 S	5/2011	Giese	
D369,722 S	5/1996	Lopez, Jr. et al.	D640,102 S	6/2011	Hawkins	
D370,159 S	5/1996	Fenton et al.	D645,248 S	9/2011	Osiecki et al.	
D376,068 S	12/1996	Coy	D646,528 S	10/2011	Stallman et al.	
5,607,195 A	3/1997	Antonucci	D651,860 S	1/2012	Nie	
D380,369 S	7/1997	Antonucci	D660,885 S	5/2012	Crawford	
D386,649 S	11/1997	Arnfelt	8,210,702 B1	7/2012	Sandberg	
5,683,097 A	11/1997	Fenton et al.	D694,070 S	11/2013	Torres	
5,735,428 A	4/1998	Chern	D712,720 S	9/2014	Seiders	
5,738,238 A	4/1998	Yang	D712,721 S	9/2014	Seiders	
5,742,990 A	4/1998	Antonucci	D712,722 S	9/2014	Seiders	
D394,550 S	5/1998	Tanji	D712,723 S	9/2014	Seiders	
D396,779 S	8/1998	Moffett, III et al.	D714,125 S	9/2014	Seiders	
D397,585 S	9/1998	Rausch et al.	8,910,819 B2	12/2014	Seiders	
D398,816 S	9/1998	Koutsouflakis	D727,134 S *	4/2015	Yamamoto	D8/331
D407,609 S	4/1999	Rausch	D740,100 S *	10/2015	Alfredsson	D8/330
5,926,927 A *	7/1999	Winkler	9,187,232 B2	11/2015	Seiders	
		A41F 1/008 24/593.1	D747,950 S	1/2016	Jacobsen et al.	
D415,393 S	10/1999	Kei	D747,951 S	1/2016	Jacobsen et al.	
D415,658 S	10/1999	Frehse	D748,452 S	2/2016	Jacobsen et al.	
D421,552 S	3/2000	Frehse	D750,953 S	3/2016	Jacobsen et al.	
D423,294 S	4/2000	Klein et al.	D759,590 S *	6/2016	Wang	D13/119
D429,606 S	8/2000	Israel et al.	D779,306 S *	2/2017	Finkelstein	D8/331
D437,736 S	2/2001	Moffett, III et al.	2008/0025544 A1	1/2008	Maldonado	
D439,406 S	3/2001	Zimmerman	2008/0110892 A1	5/2008	House	
D439,913 S	4/2001	Jobst	2009/0139245 A1	6/2009	Blackway et al.	
D454,292 S	3/2002	Plummer et al.	2011/0203297 A1	8/2011	Oberweis	
6,398,272 B1	6/2002	Plummer et al.	2012/0132657 A1	5/2012	Seiders	
D467,470 S	12/2002	Cantor et al.	2014/0252010 A1	9/2014	Miller	

* cited by examiner

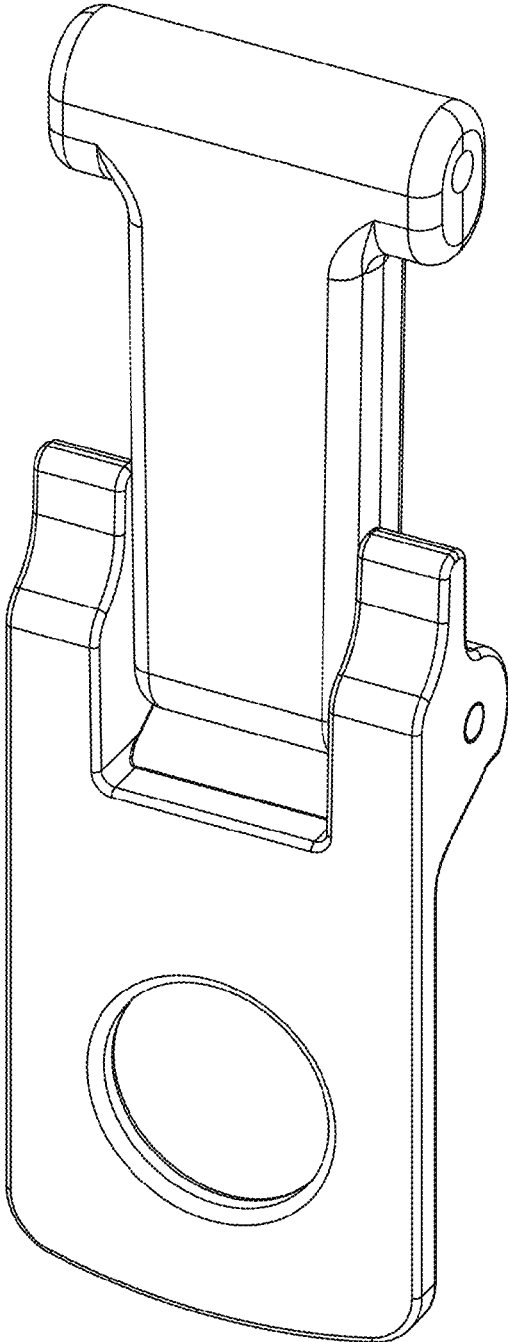

Figure 1

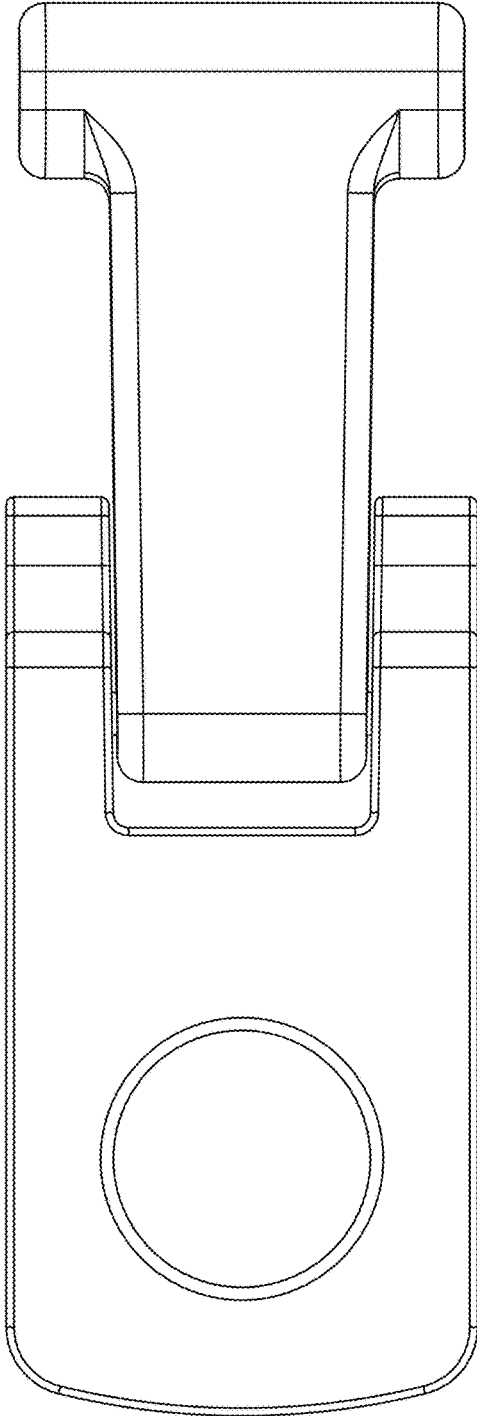

Figure 2

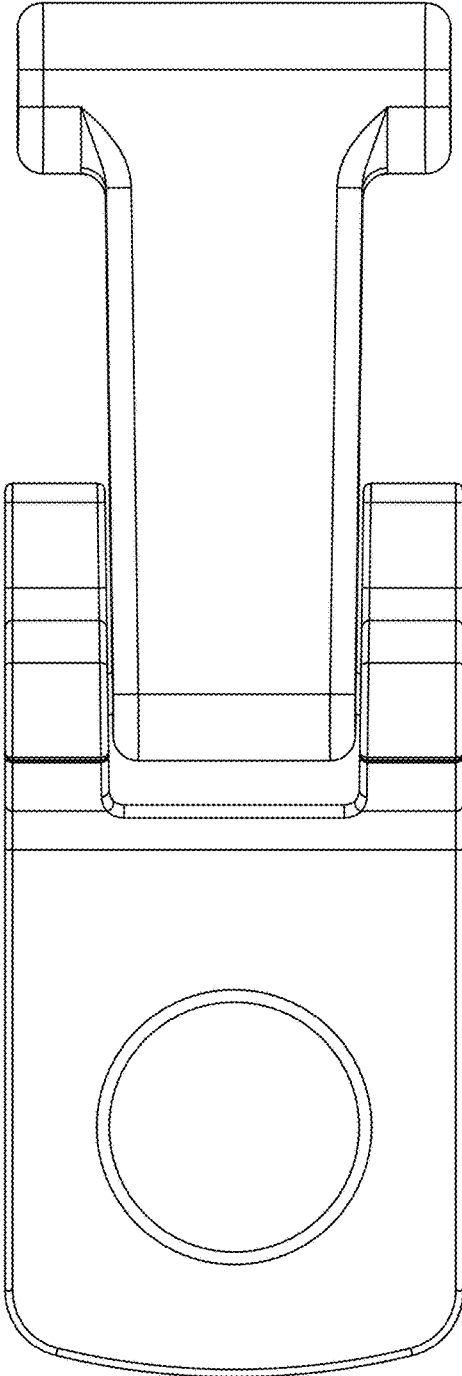

Figure 3

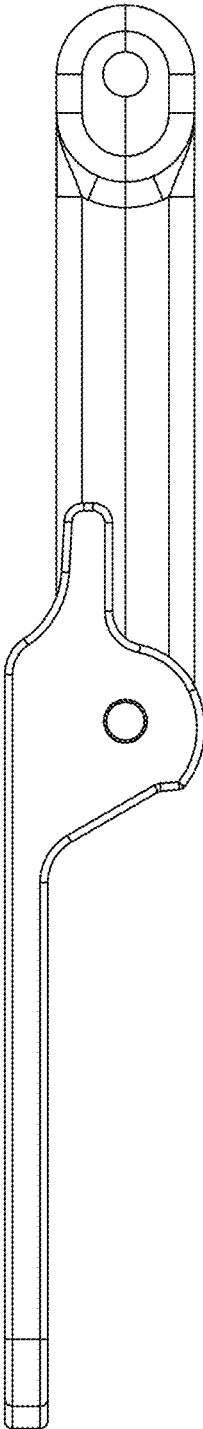

Figure 4

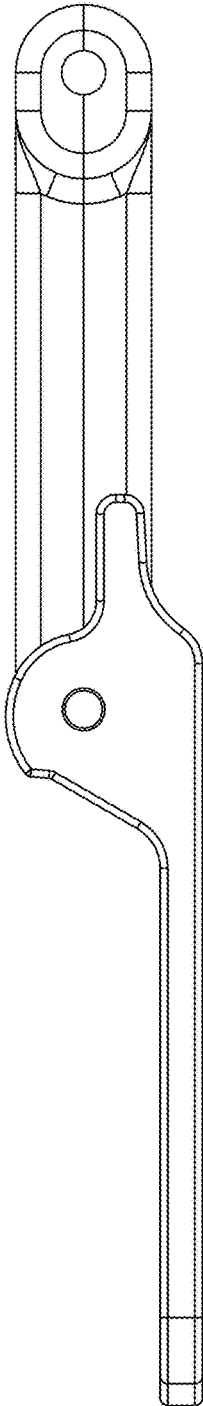

Figure 5

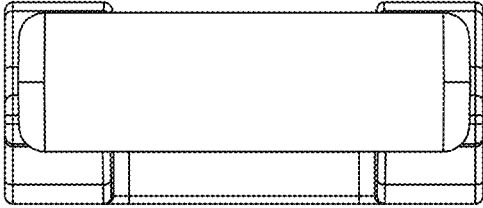

Figure 6

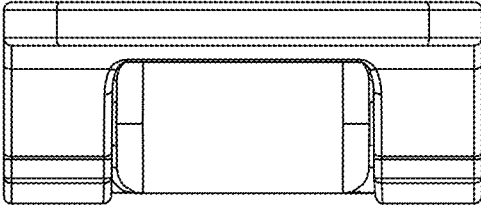

Figure 7

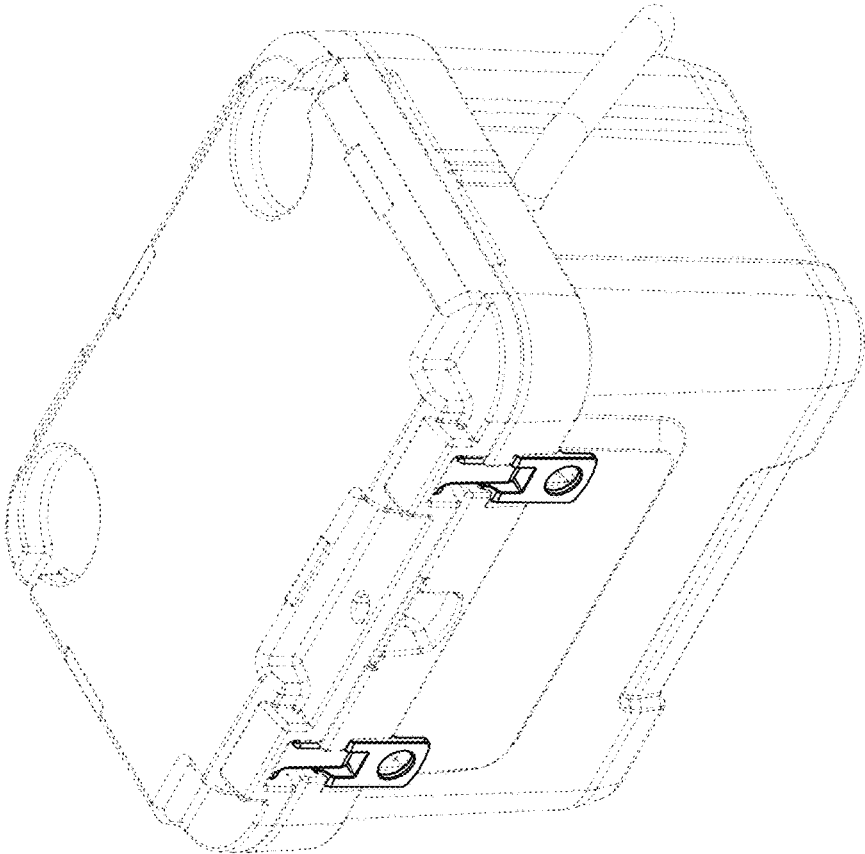

Figure 8

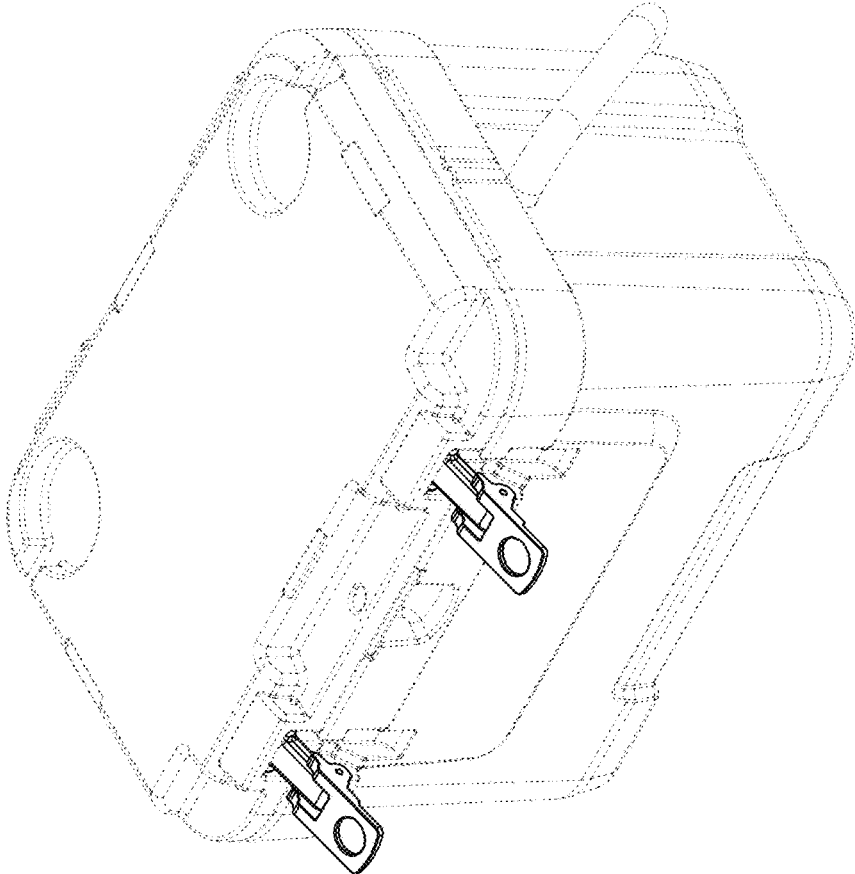

Figure 9

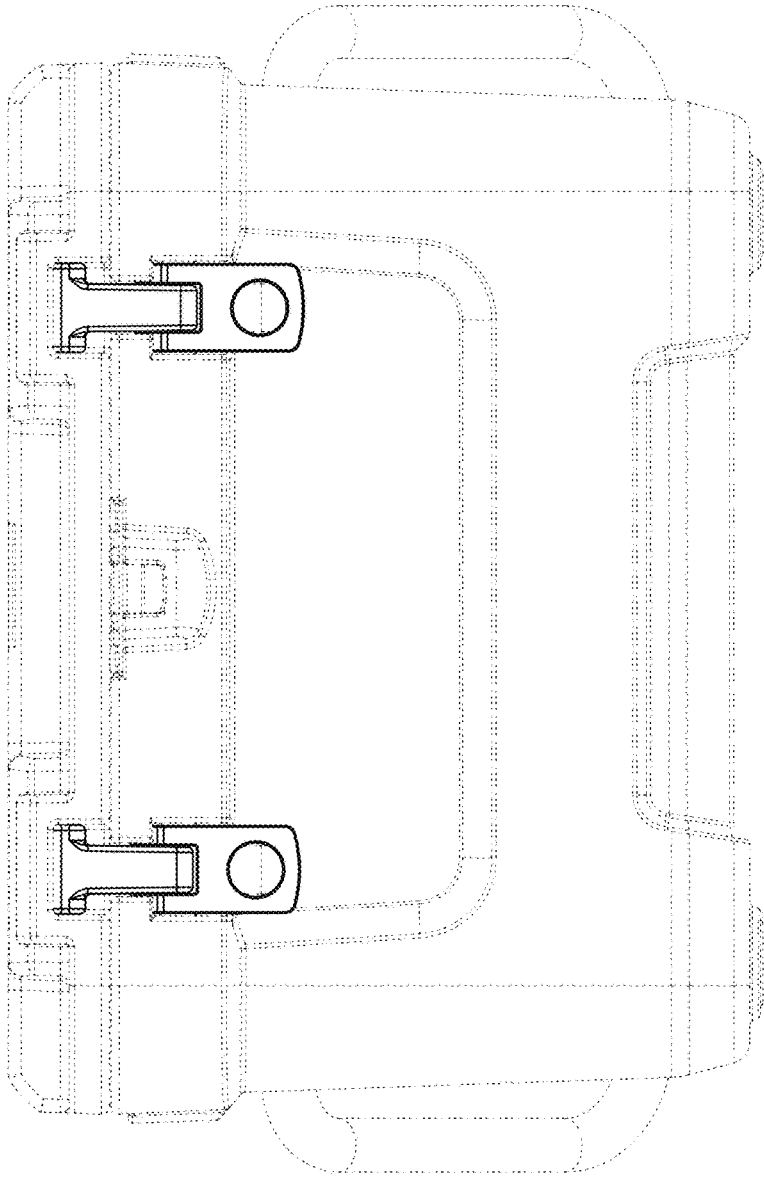

Figure 10

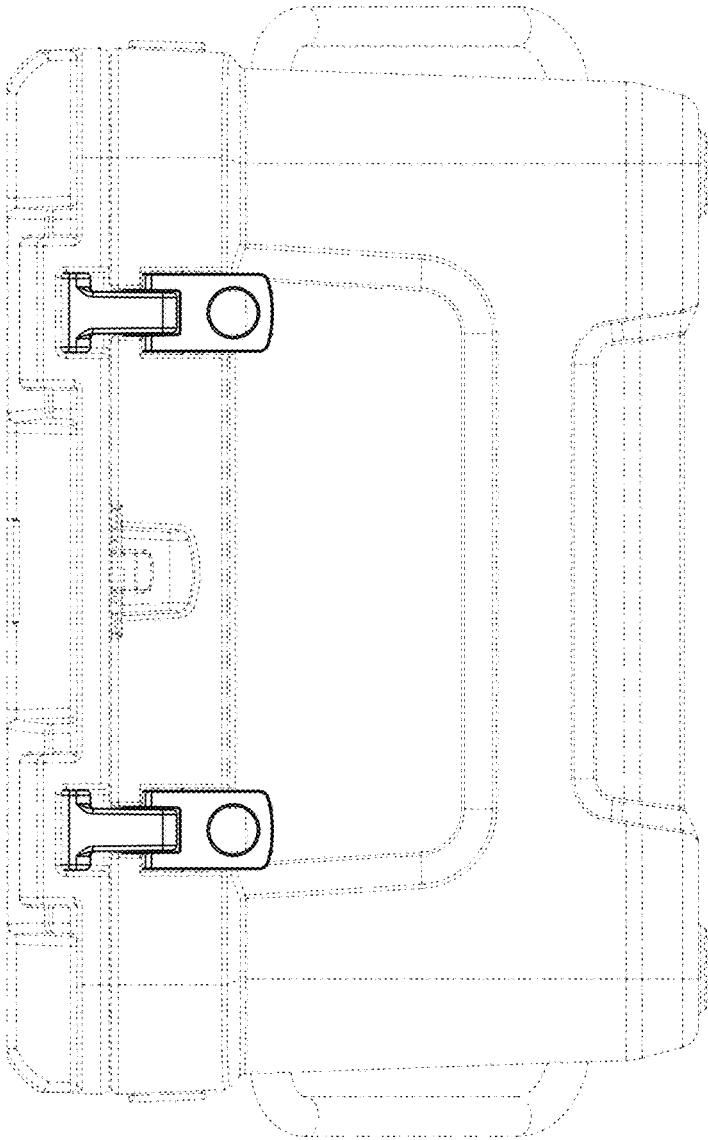

Figure 11

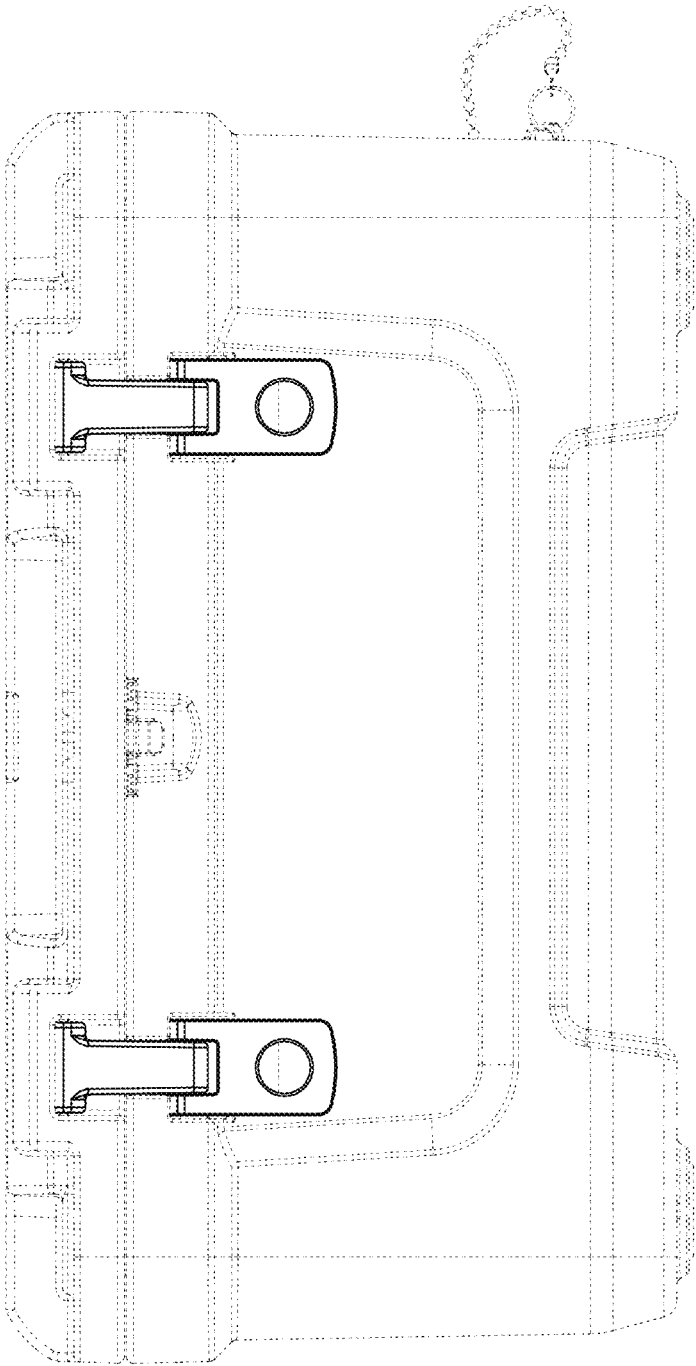

Figure 12

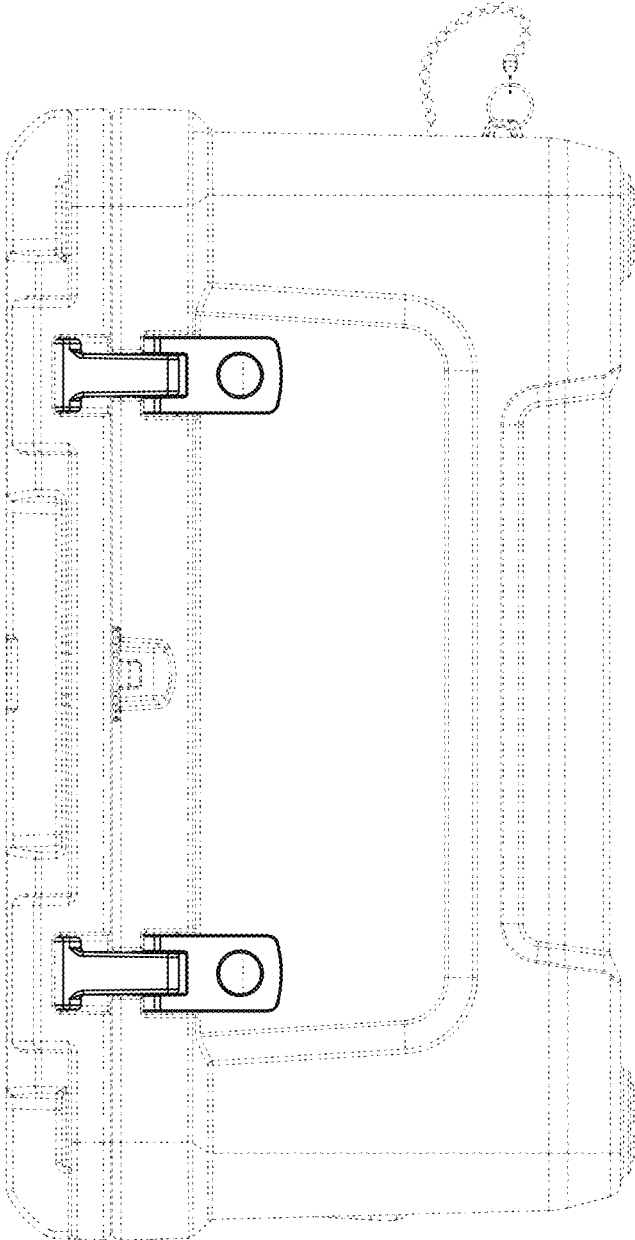

Figure 13