



(51) International Patent Classification:
E04F 15/10 (2006.01)

(21) International Application Number:
PCT/IB2015/057389

(22) International Filing Date:
25 September 2015 (25.09.2015)

(25) Filing Language: Dutch

(26) Publication Language: English

(30) Priority Data:
62/055,809 26 September 2014 (26.09.2014) US

(71) Applicant: FLOORING INDUSTRIES LIMITED, SARL [IE/LU]; 10b, Rue des Mérovingiens, (ZI Bourmicht), L-8070 Bertrange (LU).

(72) Inventor: CAPPELLE, Mark; Cardijnlaan 8, B-8840 Staden (BE).

(74) Agents: VAN HOOYDONCK, Guy et al.; Unilin Industries BVBA, Ooigemstraat 3, B-8710 Wielsbeke (BE).

(81) Designated States (unless otherwise indicated, for every kind of national protection available): AE, AG, AL, AM, AO, AT, AU, AZ, BA, BB, BG, BH, BN, BR, BW, BY, BZ, CA, CH, CL, CN, CO, CR, CU, CZ, DE, DK, DM,

DO, DZ, EC, EE, EG, ES, FI, GB, GD, GE, GH, GM, GT, HN, HR, HU, ID, IL, IN, IR, IS, JP, KE, KG, KN, KP, KR, KZ, LA, LC, LK, LR, LS, LU, LY, MA, MD, ME, MG, MK, MN, MW, MX, MY, MZ, NA, NG, NI, NO, NZ, OM, PA, PE, PG, PH, PL, PT, QA, RO, RS, RU, RW, SA, SC, SD, SE, SG, SK, SL, SM, ST, SV, SY, TH, TJ, TM, TN, TR, TT, TZ, UA, UG, US, UZ, VC, VN, ZA, ZM, ZW.

(84) Designated States (unless otherwise indicated, for every kind of regional protection available): ARIPO (BW, GH, GM, KE, LR, LS, MW, MZ, NA, RW, SD, SL, ST, SZ, TZ, UG, ZM, ZW), Eurasian (AM, AZ, BY, KG, KZ, RU, TJ, TM), European (AL, AT, BE, BG, CH, CY, CZ, DE, DK, EE, ES, FI, FR, GB, GR, HR, HU, IE, IS, IT, LT, LU, LV, MC, MK, MT, NL, NO, PL, PT, RO, RS, SE, SI, SK, SM, TR), OAPI (BF, BJ, CF, CG, CI, CM, GA, GN, GQ, GW, KM, ML, MR, NE, SN, TD, TG).

Declarations under Rule 4.17:

- as to applicant's entitlement to apply for and be granted a patent (Rule 4.17(ii))
- of inventorship (Rule 4.17(iv))

Published:

- with international search report (Art. 21(3))

(54) Title: FLOOR PANEL FOR FORMING A FLOOR COVERING AND METHOD FOR MANUFACTURING A FLOOR PANEL.

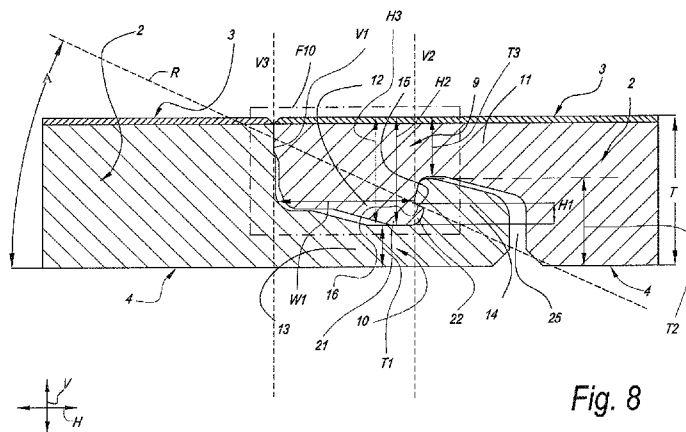

Fig. 8

(57) Abstract: Floor panel (1) for forming a floor covering, wherein this floor panel (1) comprises a substrate (2), which substrate (2) preferably is manufactured on the basis of synthetic material; wherein this floor panel (1), on at least one pair of opposite edges (5-6), comprises coupling parts (7-8), which coupling parts (7-8) allow that two such floor panels (1) can be coupled to each other by means of a downward movement (M) of one floor panel (1) in respect to the other floor panel (1).

WO 2016/046800 A1

Floor panel for forming a floor covering and method for manufacturing a floor panel.

- 5 This invention relates to a floor panel for forming a floor covering, as well as to a method for manufacturing a floor panel.

10 More particularly, the invention relates to a floor panel of the type wherein the floor panel comprises a substrate, which substrate preferably is manufactured on the basis of synthetic material; wherein this floor panel, on at least one pair of opposite edges, comprises coupling parts, which coupling parts allow that two such floor panels can be coupled to each other by means of a downward movement of one floor panel in respect to the other floor panel; wherein these coupling parts allow a locking in a first direction perpendicular to the plane of the floor panel, as well as in
15 a second direction perpendicular to the edges and in the plane of the floor panel; wherein these coupling parts substantially are formed of the material of said substrate and are made in one piece therewith; wherein these coupling parts consist of a downward-directed upper hook-shaped part, which is situated on the one edge of said pair of opposite edges, as well as of an upward-directed lower hook-shaped part, which is situated on the other, opposite edge of said pair of
20 opposite edges, which hook-shaped parts can be engaged behind each other by means of said downward movement; and wherein the upper hook-shaped part consists of a lip which is provided with a downward-directed locking element, whereas the lower hook-shaped part consists of a lip which is provided with an upward-directed locking element. Such floor panels are known, for example, from
25 EP 2 339 092 A1 and WO 2010/023042.

A general problem with such floor panels is that the locking in vertical direction can be weak. As a result of this weak locking, it is possible that, under the influence of
30 temperature, the individual floor panels set up and the coupling parts separate from each other or the floor panels move out of each other, whereby gaps may be created. This is due to shrinkage and expansion, or even warping, of the floor panels under the influence of temperature. The features of the floor panels of the state of the art are such that problems may occur already with heating by incident
35 sunlight, for example, at a window in a room.

The invention primarily aims at alternative floor panels of the above-mentioned type, wherein an improved locking is provided, wherein according to various preferred embodiments a solution can be obtained for the problems with the floor panels of the state of the art. More particularly, the invention does not only aim at providing an improved locking, but also at allowing a smooth installation of the floor panels.

To this aim, the invention relates to a floor panel as described in the independent claims 1 to 4, which respectively relate to four independent aspects of the invention. All characteristics of these independent claims or aspect can be combined at choice, as far as they are not contradictory.

Preferred, as well as deviating embodiments of these floor panels are described in the dependent claims 5 to 48.

According to the first independent aspect, the invention relates to a floor panel of the above-mentioned type, with the characteristic that the locking elements are provided with locking surfaces which at least partially allow the locking in said first direction perpendicular to the plane of the floor panels, which locking surfaces comprise a first and second locking surface, which first locking surface belongs to a proximal side of the downward-directed locking element and which second locking surface belongs to a proximal side of the upward-directed locking element; that said locking surfaces, in the coupled condition of two such floor panels, define a tangent line forming an angle with the plane of the floor panel, which angle is smaller than 30 degrees and is larger than 0 degrees, and/or that said second locking surface defines such angle; and that said locking surfaces extend continuously over the major part of the length of the respective edges.

As the locking surfaces form a rather small angle with the plane of the floor panel, the advantage is obtained that the vertical locking between the coupled floor panels can be made extremely strong. Moreover, this strong locking can be provided over the major part of the edges, as the locking surfaces extend continuously over the major part of the length of the edges. It is also noted that by the "major part" of the length of the edges at least 50%, preferably at least 75% and still more preferably at least 90% of the length of the respective edges is intended. The strong locking allows minimizing the risk of the occurrence of gaps,

for example, as a result of the setting up of the floor panels under the influence of temperature.

5 That the locking surfaces which at least partially provide for the vertical locking are situated on said proximal sides of the locking elements, offers the advantage that the floor panels can be coupled in a smooth manner. This location in fact allows a smooth deformation of the coupling parts during coupling of the floor panels. That the coupling parts can deform, can be effected by manufacturing the substrate on the basis of synthetic material. Synthetic material namely allows a certain elastic
10 deformation, such as bending and/or compressing actions, in particular when this is the synthetic material of the supple type.

According to the second independent aspect, the invention relates to a floor panel of the above-mentioned type, with the characteristic that the locking elements are
15 provided with locking surfaces which at least partially allow the locking in said first direction perpendicular to the plane of the floor panels, which locking surfaces comprise a first and second locking surface, which first locking surface belongs to a proximal side of the downward-directed locking element and which second locking surface belongs to a proximal side of the upward-directed locking element;
20 that said locking surfaces, in the coupled condition of two such floor panels, define a tangent line forming an angle with the plane of the floor panel, which angle is smaller than 90 degrees, and/or that said second locking surface defines such angle; and that said coupling parts are configured such that, in the coupled condition of two such floor panels, at least in said first direction perpendicular to
25 the plane of the floor panel a tensioning force is present at the location of the locking surfaces, and/or that at least in said second direction perpendicular to the edges and in the plane of the floor panel a tensioning force is present at the location of a vertical closing surface formed between the two floor panels.

30 As already mentioned in respect to the first aspect, the location of the locking surfaces offers the advantage that the floor panels can be installed in a smooth manner. In fact, the location allows a smooth deformation of the coupling parts during the coupling of the floor panels. That the coupling parts can deform, can be effected by manufacturing the substrate on the basis of synthetic material. To wit,
35 synthetic material allows a certain elastic deformation, such as bending and/or compressing actions, in particular when the synthetic material is of the supple type.

The strong locking is effected here in that the locking surfaces can define an undercut, as well as also in that the mentioned tensioning force is present. The synergy between both results in a particularly close connection between the mutually coupled floor panels, by which a possible gap formation can be counteracted. Moreover, the mentioned tensioning force allows to at least partially accommodate tolerances which occur, for example, by means of milling treatments, during manufacturing of the coupling parts.

According to the third independent aspect, the invention relates to a floor panel of the above-mentioned type, with the characteristic that the locking elements are provided with locking surfaces which at least partially allow the locking in said first direction perpendicular to the plane of the floor panels, which locking surfaces comprise a first and second locking surface, which first locking surface belongs to a proximal side of the downward-directed locking element and which second locking surface belongs to a proximal side of the upward-directed locking element; that said locking surfaces, in the coupled condition of two such floor panels, define a tangent line forming an angle with the plane of the floor panel, which angle is smaller than 90 degrees, and/or that said second locking surface defines such angle; that the floor panel, on distal sides of the locking elements, is free from locking parts which, partially or entirely, allow a locking in an aforementioned first direction; that said locking surfaces, in the coupled condition of two such floor panels, seen in cross-section, are situated entirely in the lower half of the floor panel; and that said locking surfaces extend continuously over the major part of the length of the respective edges.

As already mentioned in respect to the first and the second aspect, the location of the locking surfaces offers the advantage that the floor panels can be installed in a smooth manner. The location, to wit, allows a smooth deformation of the coupling parts during coupling of the floor panels. That the coupling parts can deform, can be effected by manufacturing the substrate on the basis of synthetic material. To wit, synthetic material allows a certain elastic deformation, such as bending and/or compressing actions, in particular when that synthetic material is of the supple type.

Moreover, the smooth installation of the floor panels is also effected in that the distal sides of the locking elements are free from locking parts which contribute to the vertical locking.

The installation ease is still increased in that the locking surfaces are situated entirely in the lower half of the floor panel. In this way, these locking surfaces can be realized relatively compact. Moreover, such rather low location in the floor panel
5 allows making the lip of the lower hook-shaped part at the position of the locking surfaces relatively thin. Thus, this lip can be provided with the necessary flexibility in order to allow a certain elastic deformation.

Notwithstanding that the herein above-mentioned distal sides are free from vertical
10 locking parts, still a strong locking can be provided in that the locking surfaces define the described angle, as well as in that they extend continuously over the major part of the length of the edges.

According to the fourth independent aspect, the invention relates to a floor panel of
15 the above-mentioned type, with the characteristic that the locking elements are provided with locking surfaces which at least partially allow the locking in said first direction perpendicular to the plane of the floor panels, which locking surfaces comprise a first and second locking surface, which first locking surface belongs to a proximal side of the downward-directed locking element and which second
20 locking surface belongs to a proximal side of the upward-directed locking element; that said locking surfaces, in the coupled condition of two such floor panels, define a tangent line forming an angle with the plane of the floor panel, which angle is smaller than 90 degrees, and/or that said second locking surface defines such angle; that the downward-directed locking element comprises a protrusion,
25 whereof, in the coupled condition of two such floor panels, at least a portion is situated beyond a vertical tangent line, which vertical tangent line touches the upward-directed locking element in a most proximally situated point of this upward-directed locking element; that the maximum height of said portion is at least $1/5$ of the maximum thickness of the downward-directed locking element and maximum
30 $1/4$ of this maximum thickness; that the horizontal distance between said most proximally situated point of the upward-directed locking element and the edge of the floor panel is larger than the vertical distance between the upper side of the floor panel and the most downward-situated point of the lip of the lower hook-shaped part, and that said locking surfaces extend continuously over the major
35 part of the length of the respective edges of the floor panel.

As already stated in respect to the first, the second and the third aspect, the location of the locking surfaces offers the advantage that the floor panels can be installed in a smooth manner. The location, to wit, allows a smooth deformation of the coupling parts during coupling of the floor panels. That the coupling parts can
5 deform, can be effected by manufacturing the substrate on the basis of synthetic material. To wit, synthetic material allows a certain elastic deformation, such as bending and/or compressing actions, in particular when that synthetic material is of the supple type.

10 In that the locking surfaces define the described angle, as well as in that they extend continuously over the major part of the edges, the advantage is obtained that a strong vertical locking can be effected. This strong vertical locking can also be effected by the deliberately chosen height of the mentioned protrusion, which is of sufficient thickness to provide for the desired locking, however, is made such
15 that the floor panels may be coupled in a smooth manner. That the horizontal distance between the aforementioned most proximally situated point of the upward-directed locking element and the edge of the floor panel is larger than the vertical distance between the upper side of the floor panel and the most downward-directed point of the lip of the lower hook-shaped part, contributes to the
20 strength of the locking, in view of the fact that this characteristic allows to make the downward-directed locking element extremely stable. As this downward-directed locking element can be made stable, also the advantage is created that the risk of breaking, for example, during coupling of the floor panels, can be minimized, thus, contributing to the smooth installation of the floor panels.

25 Said tangent line and/or the straight line through said second locking surface preferably is directed upward in the direction of a vertical, formed by a vertical closing surface, between two such floor panels in coupled condition. Still more preferably, said tangent line and/or the straight line through said second locking
30 surface closes off said vertical through the vertical closing surface in such a manner that the intersection with this vertical is situated at maximum 2 mm, and preferably maximum 1 mm, above the upper side of the floor panel. In particular, said intersection is situated underneath the upper side of the floor panel. Such configuration of the tangent line and/or the straight line through the second locking
35 surface allows a particularly strong vertical locking between the coupled floor panels, whereas the floor panels still can be coupled to each other in a smooth manner.

On a distal side of the downward-directed locking element, the floor panel can be free from locking parts which partially or entirely allow a locking in an aforementioned first direction. This increases the installation ease of the floor panels. With the same aim, the floor panel, on a distal side of the upward-directed locking element, can be free from locking parts which partially or entirely allow a locking in an aforementioned first direction.

The coupling parts preferably are configured such that in the coupled condition of two such floor panels, the downward-directed locking element is clamped between a vertical closing surface, which is formed between the two floor panels and the proximal side of the upward-directed locking element. Such clamping offers the advantage that possible gap formation, for example, as a consequence of the setting up of the floor panels under the influence of temperature, can be counteracted. By such clamping, the floor panels also can be coupled in a smooth manner, in view of the fact that the clamping can provide for that a clicking effect is clearly perceptible during coupling of the floor panels.

The thickness of the floor panel preferably is smaller than 6 mm. Still more preferably, this thickness is smaller than 5 mm, and most preferably the thickness is smaller than 4 mm. Such thickness offers the advantage that the floor panels can be made sufficiently strong, but still are sufficiently thin, which can result in material economization. Moreover, the coupling parts of the invention are particularly suitable for being applied in floor panels with such thickness.

In the coupled condition of two such floor panels, the aforementioned locking surfaces, seen in cross-section, may be situated entirely in the lower half of the floor panel. Due to this characteristic, the locking surfaces can be made rather compact, however, still sufficiently strong. This characteristic also allows to make the floor panels relatively thin, preferably with a thickness as described herein above.

The aforementioned angle preferably is smaller than 60 degrees. Still more preferably, the angle is smaller than 45 degrees. Most preferably, the angle is smaller than 30 degrees. Hereby, a particularly strong vertical locking can be provided while still guaranteeing the installation ease of the floor panels.

Preferably, the lip of the lower hook-shaped part comprises an incision on an underside of this lip, which incision extends in horizontal direction starting from a distal side of the upward-directed locking element and at least up to said locking surfaces. Such incision contributes to the installation ease of the floor panels. In fact, it provides for that the lip of the lower hook-shaped part can bend during coupling of the floor panels, such that sufficient space can be created for the mutual engagement of the hook-shaped parts. In particular, the incision extends in horizontal direction to beyond said locking surfaces.

10 In the coupled condition of two such floor panels, an interspace is provided in the entire intermediary space between a distal side of the upward-directed locking element of the one floor panel and the edge of the other floor panel. Such interspace contributes to the installation ease of the floor panels. In particular in combination with the herein above-mentioned incision, the interspace offers the possibility of creating sufficient space for the herein above-mentioned bending of the lip of the lower hook-shaped part during coupling of the floor panels. In particular, the interspace extends up to below the lip of the upper hook-shaped part.

20 Preferably, an interspace is present between a vertical closing surface, which is formed between two such floor panels in the coupled condition and a support surface, which belongs to the lip of the lower hook-shaped part and serves for supporting the downward-directed locking element. Such interspace contributes to the smooth installation of the floor panels. In fact, the interspace allows that sufficient space is created for pressing down the downward-directed locking element in order to achieve the coupled condition. In particular, the lip of the lower hook-shaped part also comprises a floating support surface for the downward-directed locking element, wherein preferably an interspace is present between the floating support surface and the downward-directed locking element. Such floating support surface offers the advantage that a boundary is set for the possibility of pressing down the downward-directed locking element. This offers the possibility of minimizing possibly obtained height differences, for example, when walking on the installed floor panels. To this aim, said interspace has a thickness of maximum 2 mm and still more preferably has a thickness of maximum 1 mm. However, still more preferably, the interspace between the floating support surface and the downward-directed locking element has a thickness of maximum 0.2 mm and most preferably of maximum 0.1 mm. The interspace between the floating support

surface and the downward-directed locking element also allows to accommodate tolerances which occur, for example, by means of milling treatments, during manufacturing of the coupling parts.

- 5 Preferably, said support surface is situated more closely to the upward-directed locking element than said floating support surface. Preferably, the support surface is situated lower than said floating support surface. Preferably, the interspace between the vertical closing surface and the support surface extends continuously from the vertical closing surface to said support surface. Such measures all
10 contribute to the installation ease of the floor panels.

The downward-directed locking element preferably comprises a protrusion, which is clamped between the second locking surface and said support surface. Hereby, a particularly strong vertical locking can be provided and it can be prevented that
15 the protrusion will come out of the locked condition, for example, under the influence of external forces.

The lip of the lower hook-shaped part preferably shows a minimum thickness which is larger than $1/4$ of the overall thickness of the floor panel. Hereby, the lip of
20 the lower hook-shaped part can be made stable. With the same aim, the lip of the lower hook-shaped part can show a minimum thickness which is larger than $1/3$, and preferably is larger than $5/12$, of the maximum thickness of the upward-directed locking element.

25 The lip of the lower hook-shaped part can show a varying thickness. This offers the possibility of providing the lip, on the one hand, with sufficient stability and providing the lip, on the other hand, with other features, such as flexibility. To this aim, the lip can be made relatively thick there, where stability is desired, whereas the lip can be made relatively thin there, where flexibility is desired. In particular,
30 the lip of the lower hook-shaped part becomes thicker in a direction away from the upward-directed locking element. Hereby, the lip can be connected to the core of the floor panel in a stable manner and can be provided with the necessary flexibility next to the upward-directed locking element. Such flexibility allows possibly bending the lip during coupling of the floor panels, such that this coupling
35 may be performed in a smooth manner.

The lip of the lower hook-shaped part preferably has a minimum thickness which is larger than $1/3$ of the overall thickness of the floor panel. Hereby, the lip of the upper hook-shaped part can be made stable. With the same aim, the lip of the upper hook-shaped part can show a minimum thickness which is larger than $1/2$ of the maximum thickness of the downward-directed locking element.

The lip of the upper hook-shaped part can show a varying thickness. This offers the possibility of providing the lip with sufficient stability, on the one hand, and providing the lip with other features, such as flexibility, on the other hand. To this aim, the lip can be made relatively thick there, where stability is desired, whereas the lip can be made relatively thin there, where flexibility is desired. In particular, the lip of the upper hook-shaped part becomes thicker in a direction away from the downward-directed locking element. Hereby, the lip can be connected to the core of the floor panel in a stable manner and can be provided with the necessary flexibility next to the downward-directed locking element. Such flexibility allows possibly bending the lip during coupling of the floor panels, such that this coupling may be performed in a smooth manner

Preferably, the coupling parts substantially are made massive. This means that, although weakened portions and/or recesses may be provided in the coupling parts, these are restricted such that they do not substantially determine the deformation of the coupling parts during coupling. Most preferably, the coupling parts are made massive and the coupling parts thus are free from weakened parts and/or recesses which allow deformations of the coupling parts.

Preferably, the floor panel is oblong, wherein the aforementioned pair of opposite edges is situated on the short sides of the floor panel and wherein the pair of opposite edges on the long sides of the floor panel also comprises coupling parts which allow a locking in a first direction perpendicular to the plane of the floor panel, as well as in a second direction perpendicular to said edges on the long sides and in the plane of the floor panel.

The coupling parts on the opposite pair of edges on the long sides of the floor panel preferably are configured such that two such floor panels can be coupled at these edges by means of a turning movement of one floor panel in respect to the other floor panel, in such a manner that a plurality of such floor panels can be coupled by means of the so-called "fold-down" technique.

The coupling parts on the opposite pair of edges on the long sides can be configured such that two such floor panels can be coupled at these edges by means of a horizontal snap movement of one floor panel in respect to the other
5 floor panel.

It is also noted that the herein above-mentioned preferred and alternative features of the invention can be combined at choice with each of the independent aspects, as far as these do not create any contradictions, or as far as they are not already
10 mentioned as a feature in the respective aspect.

The present invention also relates to a method as described in the independent claim 49 and 52.

15 Preferred, as well as deviating embodiments of this method are described in the dependent claims 50 to 51 and 53 to 58.

The invention relates to a method for manufacturing a floor panel for forming a floor covering, wherein this floor panel comprises a substrate, which substrate is
20 manufactured on the basis of synthetic material and comprises filling means; wherein this floor panel, on at least one pair of opposite edges, comprises coupling parts; and wherein these coupling parts allow a locking in a first direction perpendicular to the plane of the floor panel, as well as in a second direction perpendicular to the edges and in the plane of the floor panel; with the
25 characteristic that at least a portion of said coupling parts is manufactured from the material of said substrate by means of planing and/or scraping treatments, preferably broach and/ or broaching treatments. Such planing and/or scraping treatments offer the advantage that the coupling parts can be made very precisely. In particular, they can be advantageously employed for precise manufacturing of
30 finer portions of the coupling parts, such as an undercut or the like. Moreover, the inventor rather unexpectedly has found that such treatments can be successfully applied in substrates which comprise fillers.

The filling means can consist of plasticizers and/or fillers, such as chalk and/or
35 limestone. Such filling means allow giving new features to the synthetic substrate, for example, in the field of strength or flexibility. At the same time, fillers such as chalk and/or limestone offer economic advantages. According to an alternative,

whether or not combined with the herein above-mentioned filling means, the filling means may consist of wood fibers.

5 The invention also relates to a method for manufacturing a floor panel for forming a floor covering, wherein this floor panel comprises a substrate, which substrate is manufactured on the basis of synthetic material; wherein this floor panel, on at least one pair of opposite edges, comprises coupling parts, which coupling parts allow that two such floor panels can be coupled to each other by means of a downward movement of one floor panel in respect to the other floor panel; wherein
10 these coupling parts allow a locking in a first direction perpendicular to the plane of the floor panel, as well as in a second direction perpendicular to the edges and in the plane of the floor panel; with the characteristic that least a portion of said coupling parts is manufactured from the material of said substrate by means of planing and/or scraping treatments, preferably broach and/ or broaching treatments. In that such planing and/or scraping treatments are employed, the
15 advantage is created that the coupling parts can be manufactured in a precise manner.

Preferably, the method also shows the characteristic that said coupling parts
20 consist of a downward-directed upper hook-shaped part, which is situated on the one edge of said pair of opposite edges, as well as of an upward-directed lower hook-shaped part, which is situated on the other, opposite edge of said pair of opposite edges, which hook-shaped parts can be engaged behind each other by means of said downward movement; that the upper hook-shaped part consists of a
25 lip which is provided with a downward-directed locking element, whereas the lower hook-shaped part consists of a lip which is provided with an upward-directed locking element; that the locking elements are provided with locking surfaces which at least partially allow the locking in said first direction perpendicular to the plane of the floor panels; and that at least said locking surfaces are manufactured
30 from the material of said substrate by means of planing and/or scraping treatments, preferably broach and/ or broaching treatments. The inventor has found that such planing treatments are particularly advantageous when manufacturing the mentioned locking surfaces, which at least partially provide for the vertical locking.

35

In particular, the locking surfaces comprise a first and second locking surface, which first locking surface belongs to a proximal side of the downward-directed

locking element, and which second locking surface belongs to a proximal side of the upward-directed locking element.

5 Still more particularly, said locking surfaces, in the coupled condition of two such floor panels, define a tangent line forming an angle with the plane of the floor panel, which angle is smaller than 90 degrees, and/or said second locking surface defines such angle. Such locking surfaces may define an undercut, which is difficult to manufacture by means of traditional milling treatments. However, the inventor has found that such undercuts in fact can be manufactured easily and
10 precisely by means of the mentioned planing treatments.

The remainder of the coupling parts can be manufactured substantially from the material of said substrate substantially by means of milling treatments.

15 The methods, such as described herein above, can be applied for manufacturing a floor panel according to the herein above-described aspects of the invention, as well as for manufacturing a floor panel according to their preferred and alternative embodiments.

20 The invention also relates to a floor panel as obtained according to the method according to any of the claims 49 to 58.

With the intention of better showing the characteristics of the invention, herein below, as an example without any limitative character, some preferred
25 embodiments are described, with reference to the accompanying drawings, wherein:

Figure 1 represents a floor panel according to the invention;
Figures 2 and 3, at a larger scale, represent a cross-section according to
30 the lines II-II and III-III, respectively, shown in figure 1;
Figures 4 to 7 represent how two floor panels can be coupled to each other at the edges from figure 2;
Figure 8 for clearness' sake represents the coupling parts from figure 2 in completely coupled condition;
35 Figure 9, at a larger scale, represents a view of the part indicated by F10 in figure 8;
Figures 10 to 14 represent variants of the invention;

Figures 15 and 16 represent in perspective how the long and short edges of the floor panel from figure 1 can be coupled to similar floor panels, wherein figure 16 at a larger scale provides a view on the area indicated by F11 in figure 15;

- 5 Figure 17 represents a variant of the embodiment in figure 3; and
Figures 18 and 19 represent how two floor panels can be coupled to each other at the edges from figure 3.

10 Figure 1 represents a floor panel 1 according to the invention, which can be applied for forming a floor covering. The floor panel 1 is oblong and comprises a pair of opposite edges 5-6 on the short sides of the floor panel 1 and a pair of opposite edges 30-31 on the long sides of the floor panel 1. The pair of opposite edges 5-6 comprises coupling parts 7-8, whereas the pair of opposite edges 30-31 comprises coupling parts 32-33.

15 Figure 2 represents a cross-section according to line II-II in figure 1. The floor panel 1 comprises a substrate 2, which preferably is manufactured on the basis of synthetic or thermoplastic material, such as polyvinyl chloride. The floor panel 1 comprises a top layer 28, which comprises at least a decor and a transparent or
20 translucent wear layer situated on the decor.

The coupling parts 7-8 are entirely formed from the material of the substrate 2 and are made in one piece therewith. Moreover, substantially they are made massive.

25 The coupling parts 7-8 consist of a downward-directed upper hook-shaped part 9, which is situated on the one edge 5 of said pair of opposite edges 5-6, as well as an upward-directed lower hook-shaped part 10, which is situated on the other, opposite edge 6 of the aforementioned pair of opposite edges 5-6.

30 The upper hook-shaped part 9 consists of a lip 11 which is provided with a downward-directed locking element 12, whereas the lower hook-shaped part 10 consists of a lip 13 which is provided with an upward-directed locking element 14.

35 The locking elements 12 and 14 are provided with locking surfaces 15-16, which at least partially, and here entirely, allow the locking in said first direction V perpendicular to the plane of the floor panels 1. The locking surfaces 15-16 comprise a first locking surface 15 and a second locking surface 16. The first

locking surface 15 belongs to a proximal side 17 of the downward-directed locking element 12, and the second locking surface 16 belongs to a proximal side 18 of the upward-directed locking element 14. That the locking surfaces 15-16 belong to the mentioned proximal sides 17-18, offers the advantage that the floor panels 1
5 can be coupled in a smooth manner.

On a distal side 19 of the downward-directed locking element 12, the floor panel 1 is free from locking parts, which partially or entirely allow a locking in an aforementioned first direction V. Also, the floor panel 1, on a distal side 19 of the
10 upward-directed locking element, is free from locking parts which, partially or entirely, allow a locking in an aforementioned first direction V. The absence of such locking parts on the mentioned distal sides 19-20 contributes to the possibility of smoothly coupling the floor panels 1.

15 Figure 3 represents a cross-sectional view according to line III-III in figure 1. The coupling parts 32-33 are realized in the form of a tongue and a groove, respectively.

Figure 4 to 7 represent how two floor panels 1 can be coupled to each other at the
20 edges 5-6. The coupling parts 7-8 allow that two such floor panels 1 can be coupled to each other by means of a downward movement M of one floor panel 1 in respect to the other floor panel 1.

Figure 5 represents that the coupling parts 7-8 do not just like that drop into each
25 other during the downward movement M. As a result of the presence of the locking surfaces 15-19, a resistance has to be overcome, such that the hook-shaped parts 9-10 will engage in each other. The elasticity of the synthetic material of the substrate 2 helps to overcome this resistance in view of the fact that it allows deformations of the coupling parts 7-8. Thus, it provides, together with the specific
30 configuration of the coupling parts 7-8, for a smooth coupling of the coupling parts 1 at the edges 5-6.

Hereby, it is also noted that a resistance as mentioned herein above, which is the
35 consequence of the presence of the locking surfaces 15-16 on the proximal sides 17-18, can be overcome more simply than a possible resistance which is created by locking parts present on the distal sides 19-20. Such last-mentioned resistance,

to wit, less easily allows an elastic deformation of the coupling parts, such as, for example, a downward bending of the lip of the lower hook-shaped part.

Figure 6 represents an example of a deformation of the coupling parts 7-8, wherein the lip 13 of the lower hook-shaped part 10 is bent downward when performing the downward movement M, such as represented by the dotted line. Such elastic bending of the lip 13 increases the available space for the locking element 12, such that this locking element 12 simply can be pressed down.

In an analogous way, it is possible that the lip 11 of the upper hook-shaped part 9 is bent upward when performing the downward movement M. Such upward bending of the lip 11, however, is not represented here.

Another example of a possible deformation, which is not represented here, relates to an elastic compression of the locking element 12 and/or the locking element 14, more particularly an elastic compression of the portion of the locking element 12 to which the locking surface 15 belongs and/or the portion of the locking element 14 to which the locking surface 16 belongs.

It is also noted that two or more of the herein above-described deformations may occur together when performing the coupling movement between the floor panels 1.

Figure 7 represents the floor panels 1 in coupled condition. In this coupled condition, the coupling parts 7-8 allow a locking in a first direction V perpendicular to the plane of the floor panels 1, as well as in a second direction H perpendicular to the edges 5-6 and in the plane of the floor panels 1.

Figure 8, at a larger scale, represents the coupled condition from figure 7.

The floor panel 1 shows a thickness T which is smaller than 6 mm and preferably is smaller than 5 mm, and still more preferably is smaller than 4 mm.

In the coupled condition of two such floor panels 1, the locking surfaces 15-16 define a tangent line R forming an angle A with the plane of the floor panel 1. The angle A is smaller than 30 degrees and larger than 0 degrees. More particularly, the angle A is equal to 25 degrees. Such rather minor angle offers the advantage

that a very strong vertical locking is allowed, by which the risk of height differences or gap formation between the coupled floor panels can be minimized.

5 The inventor has found that for realizing such locking surfaces 15-16, planing and/or scraping treatments, or breach and/or breaching treatments, can be applied in an advantageous matter. Such treatments allow to manufacture the locking surfaces 15-16 precisely as well as efficient. The remaining portions of the coupling part 7-8 can be realized by means of milling treatments.

10 The tangent line R is directed upward in the direction of the vertical V3 through the vertical closing surface V1 formed between the coupled floor panels 1. More particularly, the tangent line R intersects the vertical V3 in such a manner that the intersection point is situated underneath the upper side 3 of the floor panels 1. That the mentioned intersection point is situated underneath the upper side 3 of the floor panels, is also caused by the relatively small angle A, as well as by the
15 the floor panels, is also caused by the relatively small angle A, as well as by the relatively low position of the locking surfaces 15-16 in the floor panel. It offers as an advantage that a particularly strong vertical locking can be effected between the floor panels, whereas the floor panels still can be installed in a smooth manner.

20 The locking surfaces 15-16 extend continuously over the major part of the length of the edges 5-6. Hereby, a strong vertical locking can be effected over the major part of the edges.

In the coupled condition of the floor panels 1, the locking surfaces 15-16, seen in
25 cross-section, are situated entirely in the lower half of the floor panel 1. So, the locking surfaces 15-16 can be realized relatively compact, such that a smooth installation of the floor panels 1 remains possible. The resistance, as described herein above, then is sufficiently small. Such relatively low position of the locking surfaces 15-16 also offers as an advantage that the lip 13 can be made relatively
30 thin at the position of the locking surfaces 15-16, and that the lip 13 as such can undergo elastic deformations relatively easy.

The downward-directed locking element 12 comprises a protrusion 21, of which, in the coupled condition of the floor panels 1, at least a portion 22 is situated past
35 beyond the vertical tangent line V2. The vertical tangent line V2 touches the upward-directed locking element 14 in a most proximally situated point of this upward-directed locking element 14. The maximum height H1 of the part 22 is at

least $1/5$ of the maximum thickness $H2$ of the downward-directed locking element 12 and maximum $1/4$ of this maximum thickness $H2$. That the part 22 shows such height $H1$, offers the advantage that the portion can be realized relatively compact, which is beneficial for the smoothness of installation, however, can also be provided with sufficient strength in order to provide a strong vertical locking. In that the part 22 has the height $H1$, this part 22 also is extremely suitable for being applied in relatively thin floor panels 1.

The horizontal distance $W1$ between said most proximally situated point of the upward-directed locking element 14 and the edge 6 of the floor panel 1 is larger than the vertical distance $H3$ between the upper side 3 of the floor panel 1 and the most downward-situated point of the lip 13 of the lower hook-shaped part 10. That the opening for the locking element 12 is realized this wide, offers the advantage that the locking element 12 can be made very stable, such that the risk of breaking, for example, during coupling of the floor panels 1, can be minimized.

In the coupled condition of the floor panels 1, an interspace 25 is provided in the entire intermediary space between the distal side 20 of the upward-directed locking element 14 of the one floor panel 1 and the edge 5 of the other floor panel 1. The interspace 25 extends up to below the lip 11 of the upper hook-shaped part 9. Such interspace 25 contributes to the installation ease of the floor panels 1, in view of the fact that the interspace 25, for example, creates space for a possible bending of the lip 13 during the coupling movement.

The lip 13 of the lower hook-shaped part 10 shows a minimum thickness $T1$, which is larger than $1/4$ of the overall thickness T of the floor panel 1. This offers the advantage that the lip 13 can be realized sufficiently strong and stable, such that the lip 13 does not break off, for example, during the herein above-described bending. For this same purpose, the minimum thickness $T1$ of the lip 13 is larger than $1/3$ and preferably larger than $5/12$ of the maximum thickness $T2$ of the locking element 14.

Moreover, the lip 13 has a varying thickness. In this manner, the lip 13 can be provided with sufficient strength and stability, on the one hand, and obtain sufficient flexible features, on the other hand. More particularly, the lip 13 becomes thicker in a direction away from the upward-directed locking element 14. In this manner, a strong connection with the core of the floor panel 1 can be guaranteed.

With the purpose of providing the lip 11 with sufficient strength and stability, this lip 11 shows a minimum thickness $T3$ which is larger than $1/3$ of the overall thickness T of the floor panel. More particularly, the minimum thickness $T3$ is larger than $1/2$ of the maximum thickness $H2$ of the downward-directed locking element.

The lip 11 of the upper hook-shaped part 9 has a varying thickness. In this manner, the lip 11 can be provided with sufficient strength and stability, on the one hand, and obtain sufficient flexible features, on the other hand. More particularly, the lip 11 becomes thicker in a direction away from the downward-directed locking element 12. In this manner, a strong connection with the core of the floor panel 1 can be guaranteed.

Figure 9, at a larger scale, represents the part indicated by F10 in figure 8. The contours of the coupling parts 7-8, which are represented here, correspond to the contours of the coupling parts in the uncoupled condition of the floor panels 1. As represented, the coupling parts 7-8 are configured such that their contours overlap. Due to the overlapping contours, in the coupled condition one or more tensioning forces are created, which have a positive influence on the locking between the floor panels 1. Such tensioning forces allow minimizing the risk of gap formation and height differences in the installed condition of the floor panels 1.

Figure 9 represents a first tensioning force $F1$, which is present at the location of the locking surfaces 15-16. This tensioning force $F1$ provides for that the locking surfaces 15-16 are pressed towards each other and thus can effect a particularly strong locking. Moreover, a second tensioning force $F2$ is present at the location of the vertical closing surface $V1$. Hereby, the edges 5-6 present at the closing surface $V1$ are pressed towards each other, such that gap formation can be counteracted in the installed condition of the floor panels.

Figure 9 also shows that as a result of the overlapping contours, the locking element 12 is clamped between the closing surface $V1$ and the proximal side 18 of the locking element 18. Herein, also the protrusion 21 is sitting clamped between the locking surface 16 and the support surface $S1$.

Figure 9 represents that the lip 13 comprises a support surface $S1$ for supporting the locking element 12. Between this support surface $S1$ and the vertical closing

surface V1, an interspace 26 is present. This interspace 26 helps with the smooth coupling of the floor panels 1.

The lip 13 also comprises a floating support surface S2, wherein an interspace 27 is present between this support surface S2 and the locking element 12. The interspace 27 has a thickness of maximum 2 mm and preferably of maximum 1 mm. Such interspace 2 provides for the necessary space for pressing down the downward-directed locking element 12. Also, the floating support surface S2 provides for the at least partial taking up of tolerances which occur during the manufacture of the coupling parts 7-8.

The support surface S1 is situated closer to the locking element 14 than the floating support surface S2 and is situated lower than the support surface S2.

The herein above-mentioned interspace 26 extends continuously from said vertical closing surface (V2) up to said support surface (S1).

Figure 10 represents another variant of the invention, wherein the lip 13 comprises an incision 23 on the lower side 24 of the lip 13. The incision 23 extends in horizontal direction from the distal side 20 of the upward-directed locking element 14 and at least up to said locking surfaces 15-16. Such incision facilitates the possible downward bending of the lip 13 during the coupling movement. Here, the incision 23 extends to beyond the locking surfaces 15-16.

Figures 11 to 14 represent more variants of the invention, wherein the floor panel 1 is provided with one or more reinforcement layers 29.

Figure 15 represents how the floor panels 1 can be coupled to each other by means of the so-called fold-down technique. Herein, the floor panel 1C to be coupled is coupled at one of its long sides to the floor panels 1A of a preceding row, whereas the floor panel 1A simultaneously, i.e. with the same turning movement W, is coupled on one of its short sides to a floor panel 1B from the same row. To this aim, the long sides of the floor panels 1 are provided with coupling parts 32-33, which allow the coupling by means of the turning movement W, and the short sides are provided with coupling parts 7-8, which allow a coupling by means of a downward movement as a result of the turning movement W. The herein above-described coupling parts 7-8 can be applied particularly

advantageous in such so-called fold-down floor panels 1. In fact, they provide for a smooth installation, as well as for a strong locking in the coupled condition.

Figure 16 represents in an enlarged manner what is indicated by F11 in figure 15.

5

Figure 17 represents coupling parts 32-33, which allow that the floor panels can be coupled by means of a turning movement W and which can be applied in the herein above-mentioned fold-down movement. The coupling parts 32-33 allow a locking in a first direction V perpendicular to the plane of the floor panel 1, as well as in a second direction H perpendicular to the aforementioned edges 30-31 and in the plane of the floor panel 1.

10

Figure 18 represents an alternative of the coupling parts 32-33 of figure 17, which allow that the floor panels can be coupled by means of a turning movement, and can be applied with the herein above-described fold-down technique.

15

Moreover, the coupling parts 32-33 of figure 18 are configured such that they also allow a horizontal snap movement S of one floor panel 1 in respect to the other floor panel 1 in order to couple the floor panels 1. Such horizontal snap movement S is represented in figure 19.

20

It is clear that in figure 9 the shape of the coupling parts is represented such as it is in the free condition of these coupling parts. The coupling parts show an overlapping shape, such that the floor panels in coupled condition are seated in each other with a so-called "pretension".

25

It is clear that this primarily relates to decorative floor panels, thus, with a decorative upper side, for forming a floor covering on an existing supporting floor, and more particularly for forming a floating floor covering.

30

In particular, the invention is intended for floor panels which substantially consist of synthetic material, and still more for floor panels of the supple type. More particularly, the invention shows its advantages best with vinyl floor panels, in particular so-called vinyl tiles, and in particular with floor panels of the so-called LVT type ("Luxury Vinyl Tile") or VCT type ("Vinyl Composite Tile", also called "Vinyl Composition Tile").

35

Such synthetic material floor panel, and in particular supple synthetic material floor panel, and more particularly such vinyl tile, preferably shows any of the following characteristics:

- 5 - the floor panel is substantially composed of a substrate of one or more basic layers and at least a top layer, wherein the top layer as such may or may not be composed of a plurality of layers;
- herein, the top layer comprises at least a decorative layer, preferably in the form of a print, preferably provided on a foil or film;
- the top layer comprises at least a translucent or transparent wear layer;
- 10 - the floor panel substantially is composed of a thermoplastic material, preferably a soft thermoplastic material;
- the floor panel, or at least the substrate, substantially is composed of polyvinyl chloride, more particularly of soft polyvinyl chloride, more particularly provided with plasticizers or the like; a composition
15 "substantially" on the basis of PVC must be interpreted broadly in view of the fact that a large number of additives, for example, fillers, can be used in PVC floors;
- the floor panel comprises at least one reinforcement layer, preferably formed of fibers, more particularly reinforcement fibers, such as glass
20 fibers; preferably, the reinforcement layer is situated halfway the thickness of the floor panel; preferably, the reinforcement layer is not interrupted across the floor panel, which results in an increased stability of the floor panel in comparison with an interrupted reinforcement layer; preferably, the reinforcement layer is situated at the height of the protrusion (21) and/or at
25 the height of the locking surfaces (15-16), with the advantage that the strength of this protrusion and/or these locking surfaces, and consequently the strength of the vertical locking between the floor panels, is increased;

30 It is noted that "soft PVC" is a term expressing that this relates to supple PVC, in other words, PVC which is relatively readily bendable. The term soft PVC is generally known in the technique. Such soft PVC consists of PVC which is softened, preferably by means of a plasticizer added during the production process. Depending on the added amount of plasticizer, of course various degrees of suppleness can be obtained.

By a plasticizer, any material is to be understood which, by being added, results in a more supple PVC. Typical examples are phthalate plasticizers and isosorbide plasticizers.

- 5 By PVC which has been softened, of course also PVC can be understood, or a composition on the basis of PVC can be understood, which, for example, as it has been modified, as such has the feature of being supple.

10 The same is also valid for other "soft synthetic materials", and the above is not restricted to PVC.

As already mentioned herein above, the present invention shows its advantages beset when it is applied with floor panels which substantially are manufactured of supple or soft synthetic material, or in other words with supple floor panels.

15

By supple floor panels, floor panels are meant which, when they, in the case of a rectangular floor panel, for example, having a width of less than 50 centimeters, are clamped on one or both short sides of the floor panel and herein protrude over a length of 100 centimeters and are not supported, the floor panels will bend under the influence of their own weight, wherein this bending at the height of the free extremity in respect to the clamped extremity is minimum 10 centimeters. For this bending, a bending time of 10 seconds is taken into account, and wherein the floor panel starts from a flat horizontal position.

20

25 Also, the invention primarily shows its advantages best when being applied in floor panels of the WPC type ("Wood Plastics Composite").

It is clear that the coupling parts in free condition preferably show a somewhat overlapping shape, such that the floor panels in coupled condition are seated in each other with a so-called "pretension".

30

The present invention is in no way restricted to the embodiment described herein above and represented in the figures, on the contrary may such floor panel be realized in various forms and dimensions, without leaving the scope of the invention.

35

So, for example, it is noted that, although in figure 1 an oblong floor panel is represented, the invention may also be applied to square floor panels.

5 It is also noted that by an “upward-directed” locking element not only a locking element is understood which extends in height in respect to the lip of the lower hook-shaped part. By this, also a locking element is understood which extends in the height in respect to a recess which is provided in this lip and which thus does not necessarily extend higher than the lip, with the exception of this recess.

10 It is noted that by a “downward movement” not only a movement is understood having only a downward component. By this, also a so-called fold-down movement is understood, as well as a movement which, besides a substantially downward component, for example, also comprises a lateral component.

15 It is noted that by “locking surfaces” not only surfaces are understood which, in the coupled condition of two floor panels, in fact come into contact. By this, also surfaces are understood which only make contact when the one floor panel is moving upward in respect to the other floor panel, for example, under the influence of external forces, and which consequently also allow at least a locking in vertical
20 direction.

It is noted that “planing and/or scraping treatments” have to be interpreted broadly as linear cutting movements by which a thin layer can be removed from a surface. More particularly, by “planing and/or scraping treatments”, broach and/or
25 broaching treatments have to be understood.

Claims

1.- Floor panel (1) for forming a floor covering, wherein this floor panel (1) comprises a substrate (2), which substrate (2) preferably is manufactured on the basis of synthetic material; wherein this floor panel (1), on at least one pair of opposite edges (5-6), comprises coupling parts (7-8), which coupling parts (7-8) allow that two such floor panels (1) can be coupled to each other by means of a downward movement (M) of one floor panel (1) in respect to the other floor panel (1); wherein these coupling parts (7-8) allow a locking in a first direction (V) perpendicular to the plane of the floor panel (1), as well as in a second direction (H) perpendicular to the edges (5-6) and in the plane of the floor panel (1); wherein these coupling parts (7-8) substantially are formed of the material of said substrate (2) and are made in one piece therewith; wherein these coupling parts (7-8) consist of a downward-directed upper hook-shaped part (9), which is situated on the one edge (5) of said pair of opposite edges (5-6), as well as of an upward-directed lower hook-shaped part (10), which is situated on the other, opposite edge (6) of said pair of opposite edges (5-6), which hook-shaped parts (9-10) can be engaged behind each other by means of said downward movement (M); and wherein the upper hook-shaped part (9) consists of a lip (11) which is provided with a downward-directed locking element (12), whereas the lower hook-shaped part (10) consists of a lip (13) which is provided with an upward-directed locking element (14); characterized in that the locking elements (12-14) are provided with locking surfaces (15-16) which at least partially allow the locking in said first direction (V) perpendicular to the plane of the floor panels (1), which locking surfaces (15-16) comprise a first (15) and second locking surface (16), which first locking surface (15) belongs to a proximal side (17) of the downward-directed locking element (12) and which second locking surface (16) belongs to a proximal side (18) of the upward-directed locking element (14); that said locking surfaces (15-16), in the coupled condition of two such floor panels (1), define a tangent line (R) forming an angle (A) with the plane of the floor panel (1), which angle (A) is smaller than 30 degrees and larger than 0 degrees, and/or that said second locking surface (16) defines such angle (A); and that said locking surfaces (15-16) extend continuously over the major part of the length of the respective edges (5-6).

35

2.- Floor panel (1) for forming a floor covering, wherein this floor panel (1) comprises a substrate (2), which substrate (2) preferably is manufactured on the

basis of synthetic material; wherein this floor panel (1), on at least one pair of opposite edges (5-6), comprises coupling parts (7-8), which coupling parts (7-8) allow that two such floor panels (1) can be coupled to each other by means of a downward movement (M) of one floor panel (1) in respect to the other floor panel (1); wherein these coupling parts (7-8) allow a locking in a first direction (V) perpendicular to the plane of the floor panel (1), as well as in a second direction (H) perpendicular to the edges (5-6) and in the plane of the floor panel (1); wherein these coupling parts (7-8) substantially are formed of the material of said substrate (2) and are made in one piece therewith; wherein these coupling parts (7-8) consist of a downward-directed upper hook-shaped part (9), which is situated on the one edge (5) of said pair of opposite edges (5-6), as well as of an upward-directed lower hook-shaped part (10), which is situated on the other, opposite edge (6) of said pair of opposite edges (5-6), which hook-shaped parts (9-10) can be engaged behind each other by means of said downward movement (M); and wherein the upper hook-shaped part (9) consists of a lip (11) which is provided with a downward-directed locking element (12), whereas the lower hook-shaped part (10) consists of a lip (13) which is provided with an upward-directed locking element (14); characterized in that the locking elements (12-14) are provided with locking surfaces (15-16) which at least partially allow the locking in said first direction (V) perpendicular to the plane of the floor panels (1), which locking surfaces (15-16) comprise a first (15) and second locking surface (16), which first locking surface (15) belongs to a proximal side (17) of the downward-directed locking element (12) and which second locking surface (16) belongs to a proximal side (18) of the upward-directed locking element (14); that said locking surfaces (15-16), in the coupled condition of two such floor panels (1), define a tangent line (R) forming an angle (A) with the plane of the floor panel (1), which angle (A) is smaller than 90 degrees, and/or that said second locking surface (16) defines such angle (A); and that said coupling parts (7-8) are configured such that, in the coupled condition of two such floor panels (1), at least in said first direction (V) perpendicular to the plane of the floor panel (1), a tensioning force (F1) is present at the location of the locking surfaces (15-16), and/or that at least in said second direction (H) perpendicular to the edges (5-6) and in the plane of the floor panel (1), a tensioning force (F2) is present at the location of a vertical closing surface (V1) formed between the two floor panels (1).

35

3.- Floor panel (1) for forming a floor covering, wherein this floor panel (1) comprises a substrate (2), which substrate (2) is manufactured on the basis of

synthetic material and preferably has a thickness (T) which is smaller than 5 mm; wherein this floor panel (1), on at least one pair of opposite edges (5-6), comprises coupling parts (7-8), which coupling parts (7-8) allow that two such floor panels (1) can be coupled to each other by means of a downward movement (M) of one floor panel (1) in respect to the other floor panel (1); wherein these coupling parts (7-8) allow a locking in a first direction (V) perpendicular to the plane of the floor panel (1), as well as in a second direction (H) perpendicular to the edges (5-6) and in the plane of the floor panel (1); wherein these coupling parts (7-8) substantially are formed of the material of said substrate (2) and are made in one piece therewith; wherein these coupling parts (7-8) consist of a downward-directed upper hook-shaped part (9), which is situated on the one edge (5) of said pair of opposite edges (5-6), as well as of an upward-directed lower hook-shaped part (10), which is situated on the other, opposite edge (6) of said pair of opposite edges (5-6), which hook-shaped parts (9-10) can be engaged behind each other by means of said downward movement (M); and wherein the upper hook-shaped part (9) consists of a lip (11) which is provided with a downward-directed locking element (12), whereas the lower hook-shaped part (10) consists of a lip (13) which is provided with an upward-directed locking element (14); characterized in that the locking elements (12-14) are provided with locking surfaces (15-16) which at least partially allow the locking in said first direction (V) perpendicular to the plane of the floor panels (1), which locking surfaces (15-16) comprise a first (15) and second locking surface (16), which first locking surface (15) belongs to a proximal side (17) of the downward-directed locking element (12) and which second locking surface (16) belongs to a proximal side (18) of the upward-directed locking element (14); that said locking surfaces (15-16), in the coupled condition of two such floor panels (1), define a tangent line (R) forming an angle (A) with the plane of the floor panel (1), which angle (A) is smaller than 90 degrees, and/or that said second locking surface (16) defines such angle (A); that the floor panel (1), on distal sides (19-20) of the locking elements (12-14), is free from locking parts which, partially or entirely, allow a locking in an aforementioned first direction (V); that said locking surfaces (15-16), in the coupled condition of two such floor panels (1), seen in cross-section, are situated entirely in the lower half of the floor panel (1); and that said locking surfaces (15-16) extend continuously over the major part of the length of the respective edges (5-6).

35

4.- Floor panel (1) for forming a floor covering, wherein this floor panel (1) comprises a substrate (2), an upper side (3) and a lower side (4), which substrate

(2) is manufactured on the basis of synthetic material and preferably has a thickness (T) which is smaller than 5 mm; wherein this floor panel (1), on at least one pair of opposite edges (5-6), comprises coupling parts (7-8), which coupling parts (7-8) allow that two such floor panels (1) can be coupled to each other by means of a downward movement (M) of one floor panel (1) in respect to the other floor panel (1); wherein these coupling parts (7-8) allow a locking in a first direction (V) perpendicular to the plane of the floor panel (1), as well as in a second direction (H) perpendicular to the edges (5-6) and in the plane of the floor panel (1); wherein these coupling parts (7-8) substantially are formed of the material of said substrate (2) and are made in one piece therewith; wherein these coupling parts (7-8) consist of a downward-directed upper hook-shaped part (9), which is situated on the one edge (5) of said pair of opposite edges (5-6), as well as of an upward-directed lower hook-shaped part (10), which is situated on the other, opposite edge (6) of said pair of opposite edges (5-6), which hook-shaped parts (9-10) can be engaged behind each other by means of said downward movement (M); and wherein the upper hook-shaped part (9) consists of a lip (11) which is provided with a downward-directed locking element (12), whereas the lower hook-shaped part (10) consists of a lip (13) which is provided with an upward-directed locking element (14); characterized in that the locking elements (12-14) are provided with locking surfaces (15-16) which at least partially allow the locking in said first direction (V) perpendicular to the plane of the floor panels (1), which locking surfaces (15-16) comprise a first (15) and second locking surface (16), which first locking surface (15) belongs to a proximal side (17) of the downward-directed locking element (12) and which second locking surface (16) belongs to a proximal side (18) of the upward-directed locking element (14); that said locking surfaces (15-16), in the coupled condition of two such floor panels (1), define a tangent line (R) forming an angle (A) with the plane of the floor panel (1), which angle (A) is smaller than 90 degrees, and/or that said second locking surface (16) defines such angle (A); that the downward-directed locking element (12) comprises a protrusion (21), whereof, in the coupled condition of two such floor panels (1), at least a portion (22) is situated beyond a vertical tangent line (V2), which vertical tangent line (V2) touches the upward-directed locking element (14) in a most proximally situated point of this upward-directed locking element; that the maximum height (H1) of said portion (22) is at least 1/5 of the maximum thickness (H2) of the downward-directed locking element (12) and maximum 1/4 of this maximum thickness (H2); that the horizontal distance (W1) between said most proximally situated point of the upward-directed locking element (14) and the edge

(6) of the floor panel (1) is larger than the vertical distance (H3) between the upper side (3) of the floor panel (1) and the most downward-situated point of the lip (13) of the lower hook-shaped part (10), and that said locking surfaces (15-16) extend continuously over the major part of the length of the respective edges (5-6) of the floor panel (1).

5
10
5.- Floor panel according to any of the preceding claims, characterized in that said tangent line (R) and/or the straight line through said second locking surface (16) is directed upward in the direction of a vertical (V3) through a vertical closing surface (V1) formed between two such floor panels (1) in coupled condition.

15
6.- Floor panel according to claim 5, characterized in that said tangent line (R) and/or the straight line through said second locking surface (16) intersects said vertical (V3) through the vertical closing surface (V1), such that the point of intersection with this vertical (V3) is situated maximum 2 mm, and preferably maximum 1 mm above the upper side (3) of the floor panel (1).

20
7.- Floor panel according to claim 6, characterized in that said point of intersection is situated below the upper side (3) of the floor panel (1).

25
8.- Floor panel according to any of the preceding claims, characterized in that the floor panel (1), on a distal side (19) of the downward-directed locking element (12), is free from locking parts which, partially or entirely, allow a locking in an aforementioned first direction (V).

30
9.- Floor panel according to any of the preceding claims, characterized in that the floor panel (1), on a distal side (20) of the upward-directed locking element (14), is free from locking parts which, partially or entirely, allow a locking in an aforementioned first direction (V).

35
10.- Floor panel according to any of the preceding claims, characterized in that the coupling parts (7-8) are configured such that, in the coupled condition of two such floor panels (1), the downward-directed locking element (12) is clamped between a vertical closing surface (V1), which is formed between the two floor panels (1), and the proximal side (18) of the upward-directed locking element (14).

- 11.- Floor panel according to any of the preceding claims, characterized in that the floor panel (1) has a thickness (T) which is smaller than 6 mm, and preferably is smaller than 5 mm, and still more preferably is smaller than 4 mm.
- 5 12.- Floor panel according to any of the preceding claims, characterized in that said locking surfaces (15-16), in the coupled condition of two such floor panels (1), seen in cross-section, are situated entirely in the lower half of the floor panel (1).
- 10 13.- Floor panel according to any of the preceding claims, characterized in that said angle (A) is smaller than 60 degrees, and preferably smaller than 45 degrees, and still more preferably smaller than 30 degrees.
- 15 14.- Floor panel according to any of the preceding claims, characterized in that the lip (13) of the lower hook-shaped part (10) comprises an incision (23) on an underside (24) of this lip (13), which incision (23) extends in horizontal direction starting from a distal side (20) of the upward-directed locking element and at least up to said locking surfaces (15-16).
- 20 15.- Floor panel according to claim 14, characterized in that said incision (23) extends in horizontal direction to beyond said locking surfaces (15-16).
- 25 16.- Floor panel according to any of the preceding claims, characterized in that, in the coupled condition of two such floor panels (1), an interspace (25) is provided in the entire intermediary space between a distal side (20) of the upward-directed locking element (14) of the one floor panel (1) and the edge (5) of the other floor panel (1).
- 30 17.- Floor panel according to claim 16, characterized in that said interspace (25) extends up to below the lip (11) of the upper hook-shaped part (9).
- 35 18.- Floor panel according to any of the preceding claims, characterized in that a vertical closing surface (V1) is formed between two such floor panels (1) in the coupled condition; that the lip (13) of the lower hook-shaped part (10) comprises a support surface (S1) for supporting the downward-directed locking element (12); and that an interspace (26) is present between said vertical closing surface (V1) and the aforementioned support surface (S1).

- 19.- Floor panel according to claim 18, characterized in that the lip (13) of the lower hook-shaped part (10) comprises a floating support surface (S2) for the downward-directed locking element (12).
- 5 20.- Floor panel according to claim 19, characterized in that an interspace (27) is present between said floating support surface (S2) and said downward-directed locking element (12).
- 21.- Floor panel according to claim 20, characterized in that said interspace (27)
10 has a thickness of maximum 2 mm and preferably has a thickness of maximum 1 mm.
- 22.- Floor panel according to any of the claims 19 to 21, characterized in that said support surface (S1) is situated closer to the upward-directed locking element
15 (14) than said support surface (S2).
- 23.- Floor panel according to any of the claims 19 to 22, characterized in that said support surface (S1) is situated lower than said floating support surface (S2).
- 20 24.- Floor panel according to any of the claims 18 to 23, characterized in that said interspace (26) extends continuously from said vertical closing surface (V2) up to said support surface (S1).
- 25.- Floor panel according to any of the claims 18 to 24, characterized in that
25 the downward-directed locking element (12) comprises a protrusion (21), which is clamped between said second locking surface (16) and said support surface (S1).
- 26.- Floor panel according to any of the preceding claims, characterized in that the lip (13) of the lower hook-shaped part (10) has a minimum thickness (T1)
30 which is larger than $1/4$ of the overall thickness (T) of the floor panel (1).
- 27.- Floor panel according to any of the preceding claims, characterized in that the lip (13) of the lower hook-shaped part (10) has a minimum thickness (T1) which is larger than $1/3$, and preferably is larger than $5/12$, of the maximum
35 thickness (T2) of the upward-directed locking element (14).

- 28.- Floor panel according to any of the preceding claims, characterized in that the lip (13) of the lower hook-shaped part (10) has a varying thickness.
- 29.- Floor panel according to claim 28, characterized in that the lip (13) of the
5 lower hook-shaped portion (10) becomes thicker in a direction away from the upward-directed locking element (14).
- 30.- Floor panel according to any of the preceding claims, characterized in that the lip (11) of the lower hook-shaped part (9) has a minimum thickness (T3) which
10 is larger than 1/3 of the overall thickness (T) of the floor panel (1).
- 31.- Floor panel according to any of the preceding claims, characterized in that the lip (11) of the upper hook-shaped part (9) has a minimum thickness (T3) which
15 is larger than 1/2 of the maximum thickness (T2) of the downward-directed locking element (12).
- 32.- Floor panel according to any of the preceding claims, characterized in that the lip (11) of the upper hook-shaped part (9) has a varying thickness.
- 20 33.- Floor panel according to claim 32, characterized in that the lip (11) of the upper hook-shaped part (9) becomes thicker in a direction away from the downward-directed locking element (12).
- 34.- Floor panel according to any of the preceding claims, characterized in that
25 said coupling parts (7-8) substantially are made massive.
- 35.- Floor panel according to any of the preceding claims, characterized in that the substrate (2) substantially is made of synthetic material.
- 30 36.- Floor panel according to claim 35, characterized in that the floor panel (1) is of the supple type.
- 37.- Floor panel according to claim 35 or 36, characterized in that the floor panel
35 (1) substantially is composed of a thermoplastic material, preferably a soft thermoplastic material, or that at least the substrate (2) of the floor panel (1) consist of such material.

- 38.- Floor panel according to any of the claims 35 to 37, characterized in that the floor panel (1) substantially is composed of said substrate (2), which comprises one or more basic layers, and at least one top layer (28).
- 5 39.- Floor panel according to any of the claims 35 to 38, characterized in that the floor panel (1) substantially is made on the basis of polyvinyl chloride, more particularly on the basis of soft polyvinyl chloride, or at least the substrate (2) is made on the basis of polyvinyl chloride, more particularly soft polyvinyl chloride.
- 10 40.- Floor panel according to any of the claims 35 to 39, characterized in that the floor panel (1) is a vinyl panel, more particularly a so-called vinyl tile, and in particular a floor panel (1) of the so-called LVT type ("Luxury Vinyl Tile") or VCT type ("Vinyl Composite Tile", also called "Vinyl Composition Tile").
- 15 41.- Floor panel according to any of the claims 35 to 38, characterized in that the floor panel (1), or at least the substrate (2) thereof, substantially is formed on the basis of polyurethane or polypropylene.
- 42.- Floor panel according to any of the claims 35 to 41, characterized in that
20 the substrate (2) comprises one or more plasticizers, wherein these plasticizers, in the case that the substrate consists of several layers, are situated in one or more layers thereof, in particular basic layers thereof.
- 43.- Floor panel according to any of the claims 35 to 42, characterized in that
25 the substrate (2) comprises at least one filler material, such as chalk and/or limestone, wherein this filler, in the case that the substrate (2) consists of a plurality of layers, is situated in one or more layers thereof, in particular, basis layers thereof.
- 30 44.- Floor panel according to any of the claims 35 to 43, characterized in that the floor panel (1) is provided with at least one reinforcing layer (29), preferably of glass fiber or the like.
- 45.- Floor panel according to any of the claims 1 to 34, characterized in that the
35 floor panel is of the WPC type ("Wood Plastic Composite").

46.- Floor panel according to any of the preceding claims, characterized in that the floor panel (1) is oblong and that said pair of opposite edges (5-6) is situated at the short sides of the floor panel; and that the pair of opposite edges (30-31) on the long sides of the floor panel (1) also comprise coupling parts (32-33), which
5 coupling parts (32-33) allow a locking in a first direction (V) perpendicular to the plane of the floor panel (1), as well as in a second direction (H) perpendicular to said edges (30-31) and in the plane of the floor panel (1).

47.- Floor panel according to claim 46, characterized in that the coupling parts
10 (32-33) on the opposite pair of edges (30-31) on the long sides of the floor panel (1) are configured such that two such floor panels (1) can be coupled at these edges (30-31) by means of a turning movement (W) of one floor panel (1) in respect to the other floor panel (1), in such a manner that a plurality of such floor panels (1) can be coupled by means of the so-called "fold-down" technique.

15

48.- Floor panel according to claim 46 or 47, characterized in that the coupling parts (32-33) on the opposite pair of edges (30-31) on the long sides of the floor panel (1) are configured such that two such floor panels (1) can be coupled at these edges (30-31) by means of a horizontal snap movement of one floor panel
20 (1) in respect to the other floor panel (1).

49.- Method for manufacturing a floor panel (1) for forming a floor covering, wherein this floor panel (1) comprises a substrate (2), which substrate is manufactured on the basis of synthetic material and comprises fillers; wherein this
25 floor panel (1), on at least one pair of opposite edges (5-6), comprises coupling parts (7-8); and wherein these coupling parts (7-8) allow a locking in a first direction (V) perpendicular to the plane of the floor panel (1), as well as in a second direction (H) perpendicular to the edges (5-6) and in the plane of the floor panel (1); characterized in that at least a portion of said coupling parts (7-8) is
30 manufactured from the material of said substrate (2) by means of planing and/or scraping treatments, preferably broach and/ or broaching treatments.

50.- Method according to claim 49, characterized in that the fillers consist of plasticizers and/or chalk and/or limestone.

35

51.- Method according to claim 49, characterized in that the fillers consist of wood fibers.

52.- Method for manufacturing a floor panel (1) for forming a floor covering, wherein this floor panel (1) comprises a substrate (2), which substrate is manufactured on the basis of synthetic material; wherein this floor panel (1), on at least one pair of opposite edges (5-6), comprises coupling parts (7-8), which coupling parts (7-8) allow that two such floor panels (1) can be coupled to each other by means of a downward movement (M) of one floor panel (1) in respect to the other floor panel (1); wherein these coupling parts (7-8) allow a locking in a first direction (V) perpendicular to the plane of the floor panel (1), as well as in a second direction (H) perpendicular to the edges (5-6) and in the plane of the floor panel (1); characterized in that least a portion of said coupling parts (7-8) is manufactured from the material of said substrate (2) by means of planing and/or scraping treatments, preferably broach and/ or broaching treatments.

53.- Method according to claim 52, characterized in that said coupling parts (7-8) consist of a downward-directed upper hook-shaped part (9), which is situated on the one edge (5) of said pair of opposite edges (5-6), as well as an upward-directed lower hook-shaped part (10), which is situated on the other, opposite edge (6) of said pair of opposite edges (5-6), which hook-shaped parts (9-10) can be engaged behind each other by means of said downward movement (M); that the upper hook-shaped part (9) consists of a lip (11) which is provided with a downward-directed locking element (12), whereas the lower hook-shaped part (10) consists of a lip (13) which is provided with an upward-directed locking element (14); that the locking elements (12-14) are provided with locking surfaces (15-16) which at least partially allow the locking in said first direction (V) perpendicular to the plane of the floor panels (1); and that at least said locking surfaces (15-16) are manufactured from the material of said substrate (2) by means of planing and/or scraping treatments, preferably broach and/ or broaching treatments.

54.- Method according to claim 53, characterized in that said locking surfaces (15-16) comprise a first (15) and second locking surface (16), which first locking surface (15) belongs to a proximal side (17) of the downward-directed locking element (12) and which second locking surface (16) belongs to a proximal side (18) of the upward-directed locking element (14).

55.- Method according to claim 54, characterized in that said locking surfaces (15-16), in the coupled condition of two such floor panels (1), define a tangent line

(R) forming an angle (A) with the plane of the floor panel (1), which angle (A) is smaller than 90 degrees, and/or that said second locking surface (16) defines such angle (A).

5 56.- Method according to any of the claims 49 to 55, characterized in that the remainder of the coupling parts (7-8) is manufactured of the material of said substrate (2) substantially by means of milling treatments.

10 57.- Method according to any of the preceding claims 49 to 56, characterized in that it is applied for manufacturing a floor panel according to any of the claims 1 to 48.

15 58.- Method according to any of the preceding claims 49 to 57, characterized in that it is applied to a floor panel having characteristics such as defined as such in any of the claims 11 or 35 to 48.

59.- Floor panel, such as obtained according to the method according to any of the claims 49 to 58.

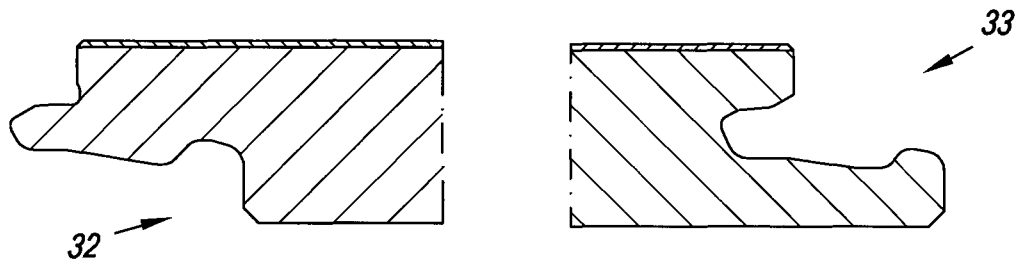
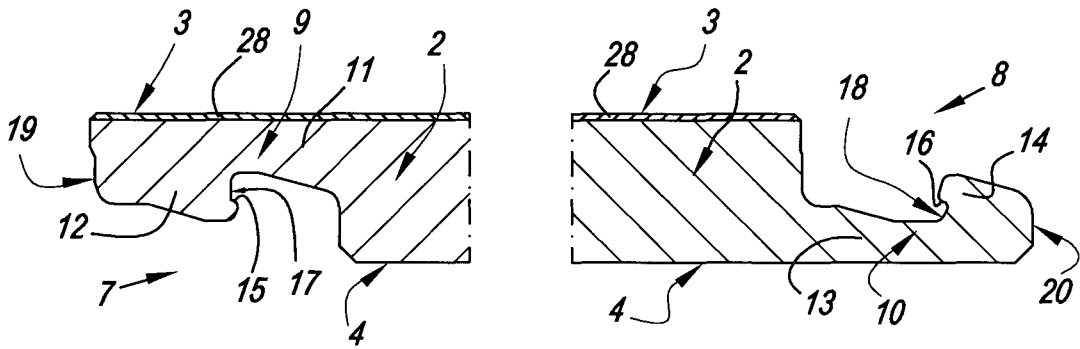
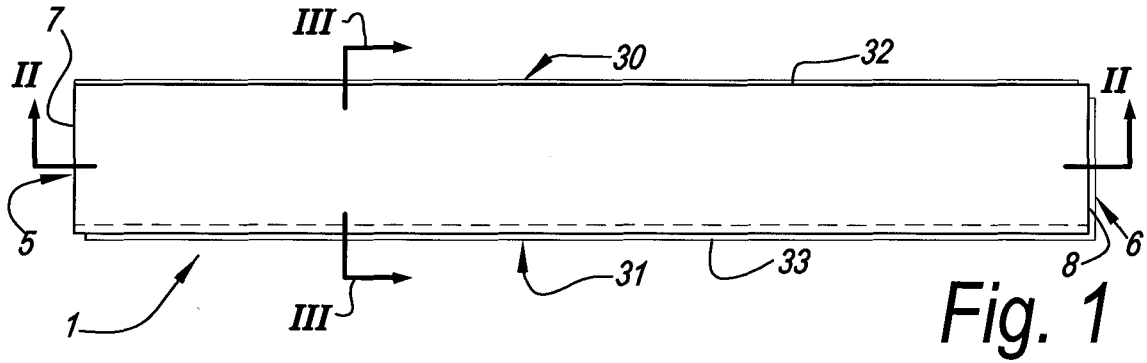

Fig. 3

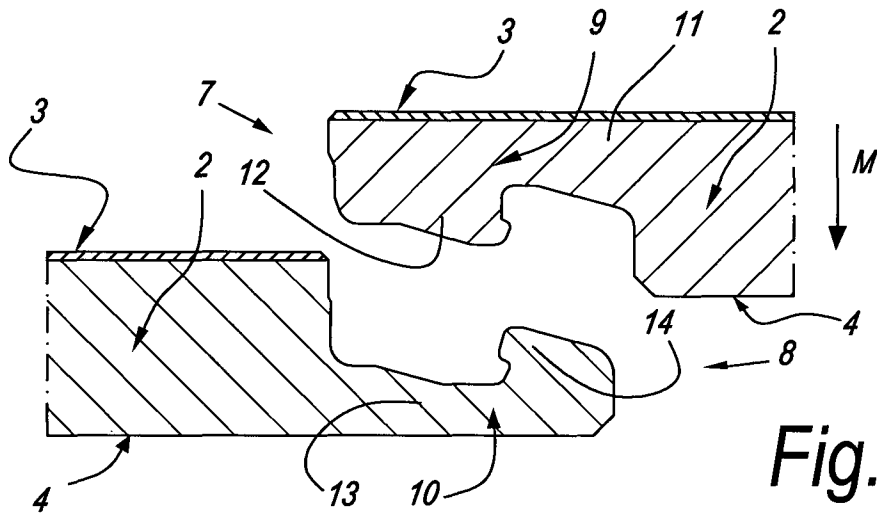

Fig. 4

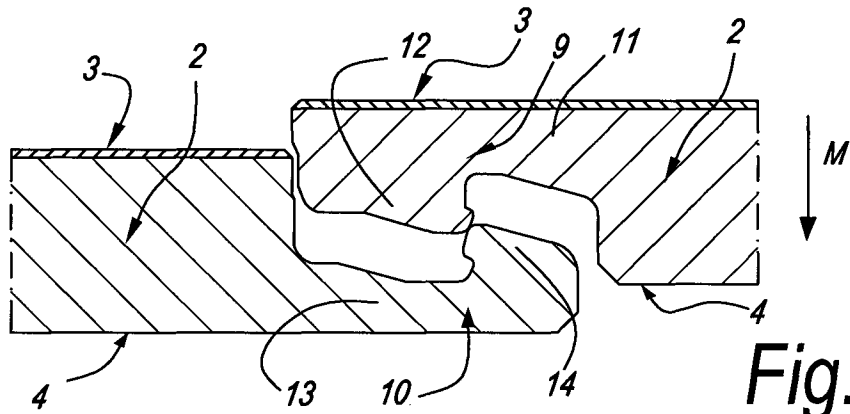

Fig. 5

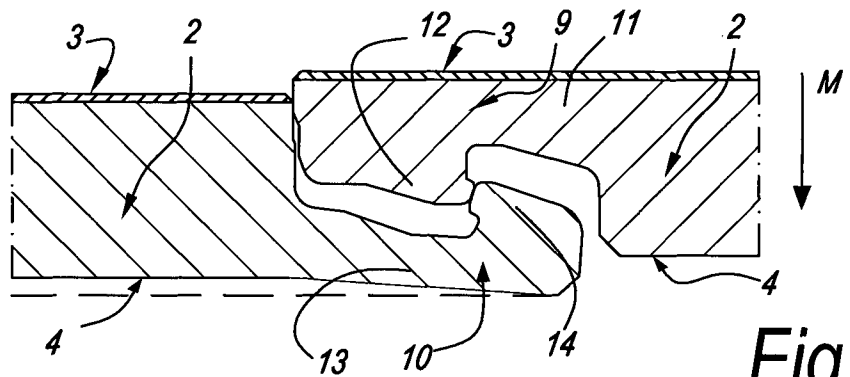

Fig. 6

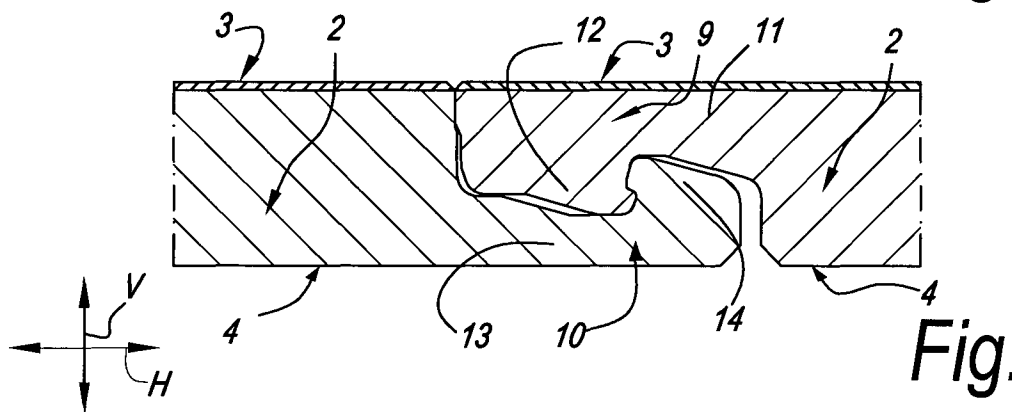

Fig. 7

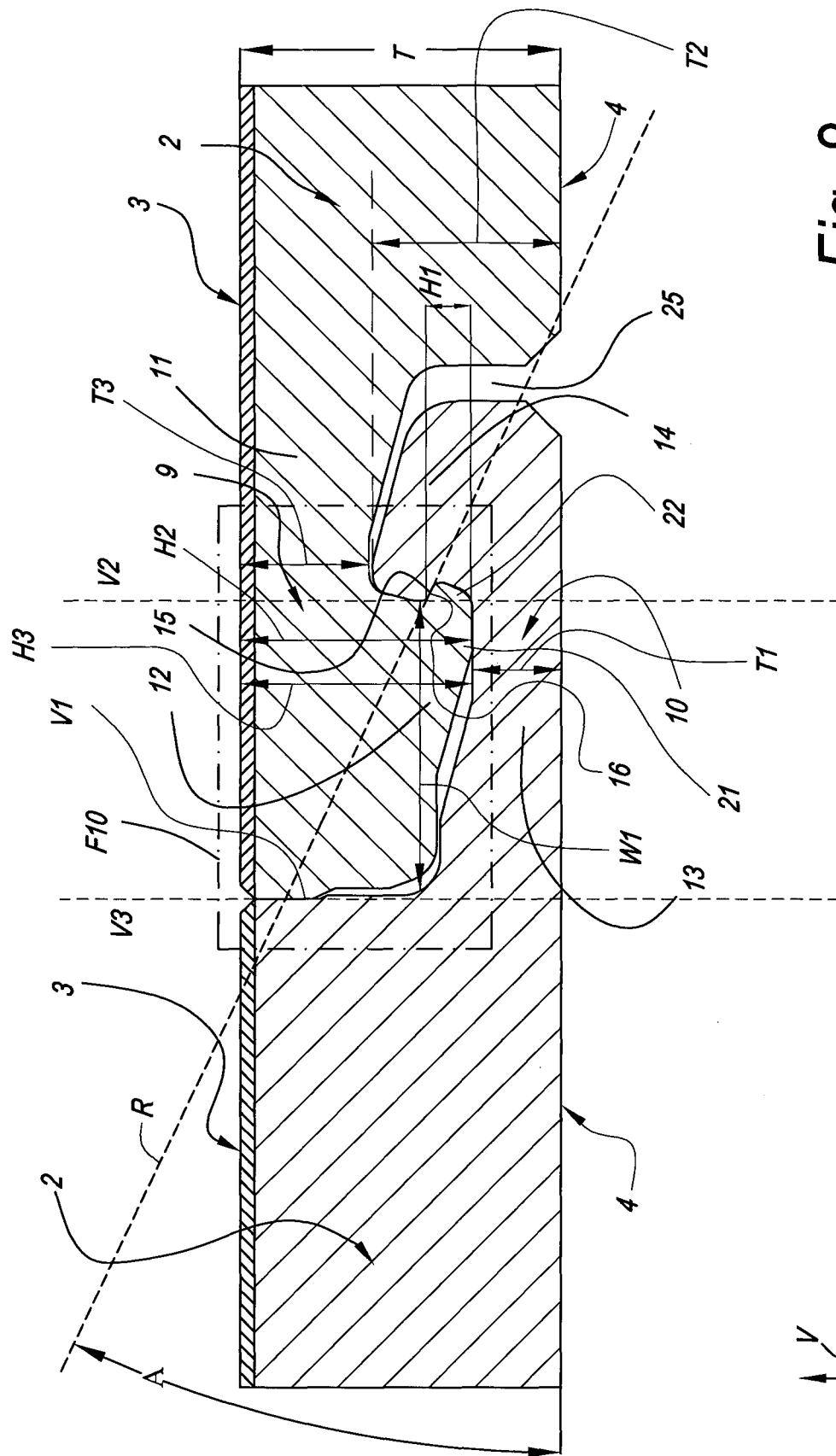

Fig. 8

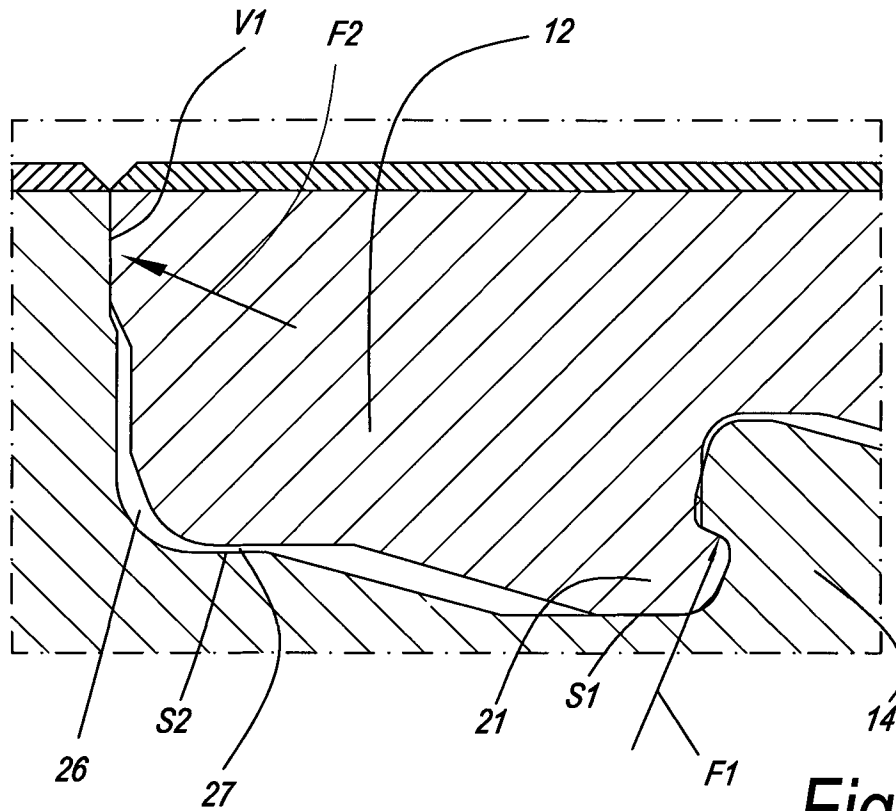

Fig. 9

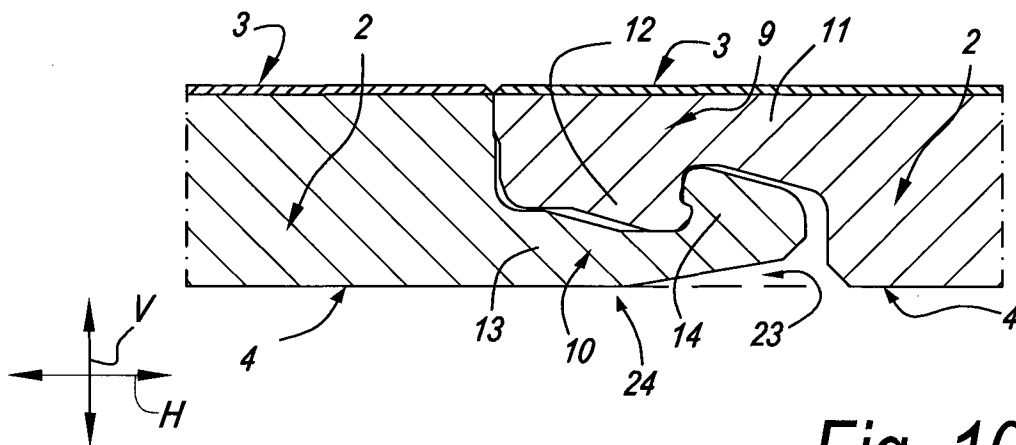

Fig. 10

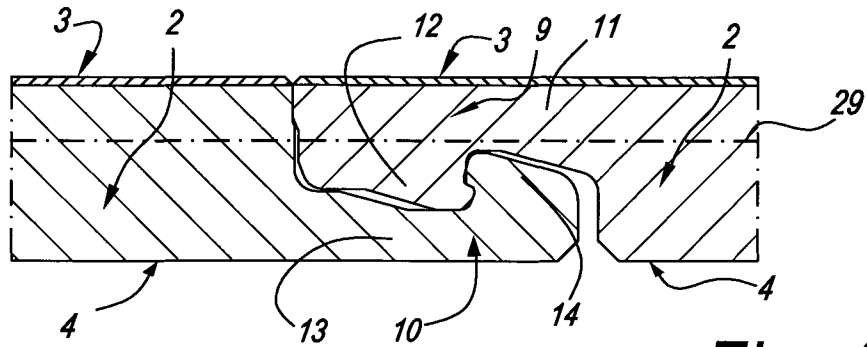

Fig. 11

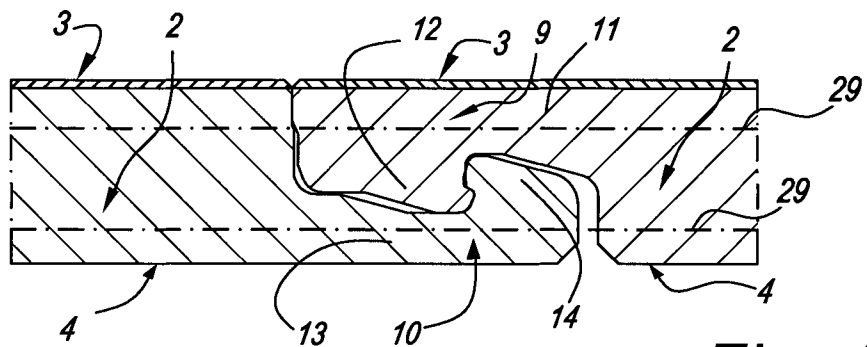

Fig. 12

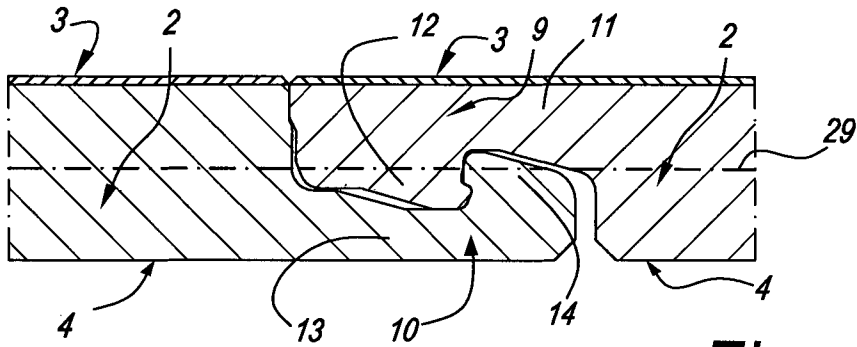

Fig. 13

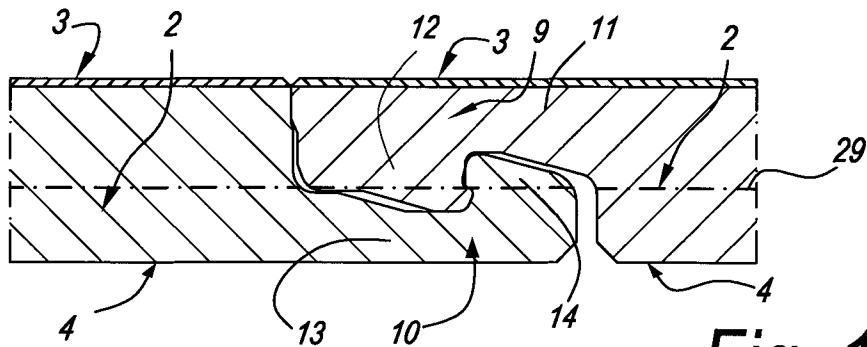

Fig. 14

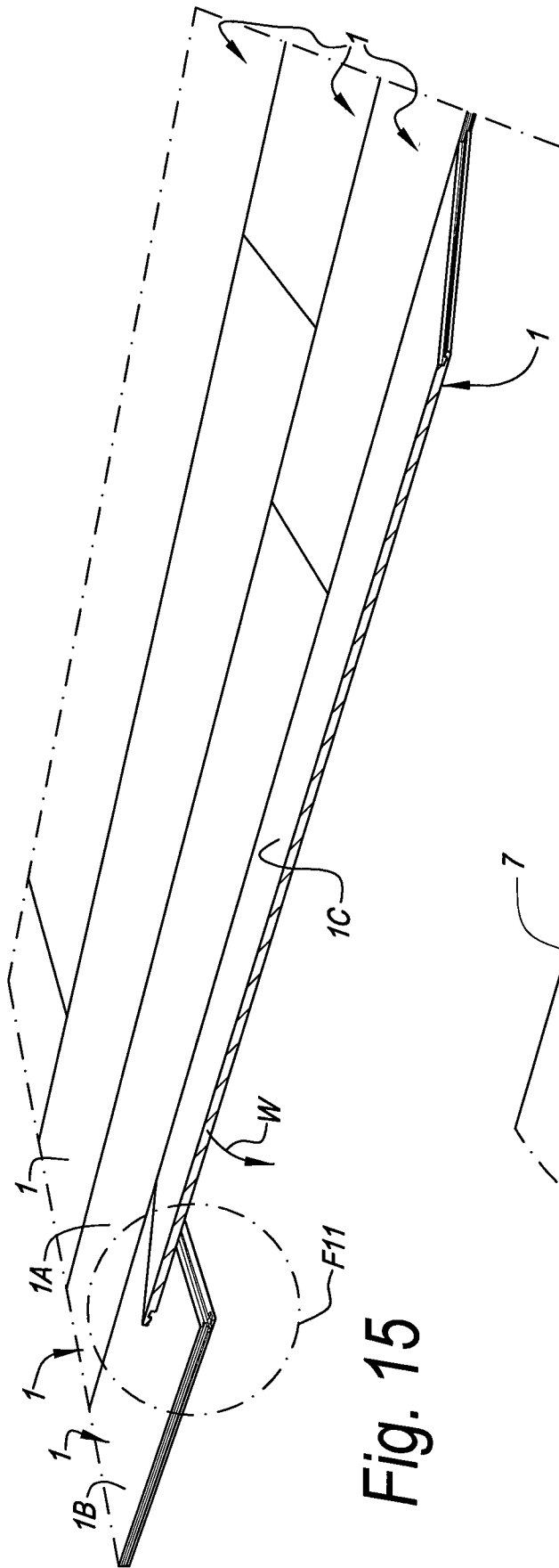

Fig. 15

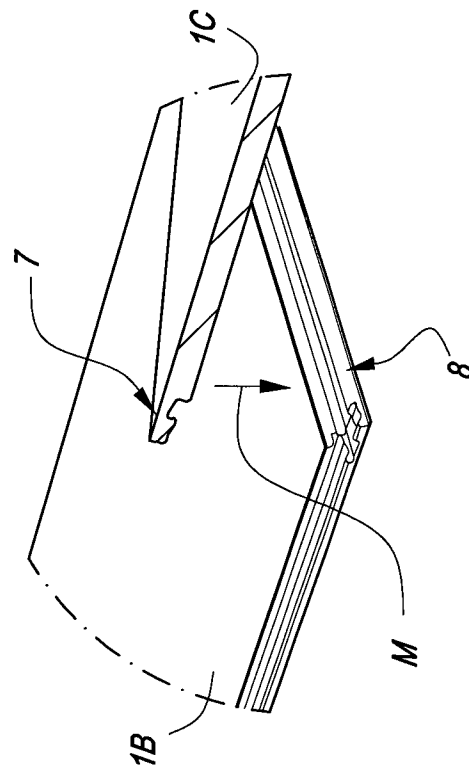

Fig. 16

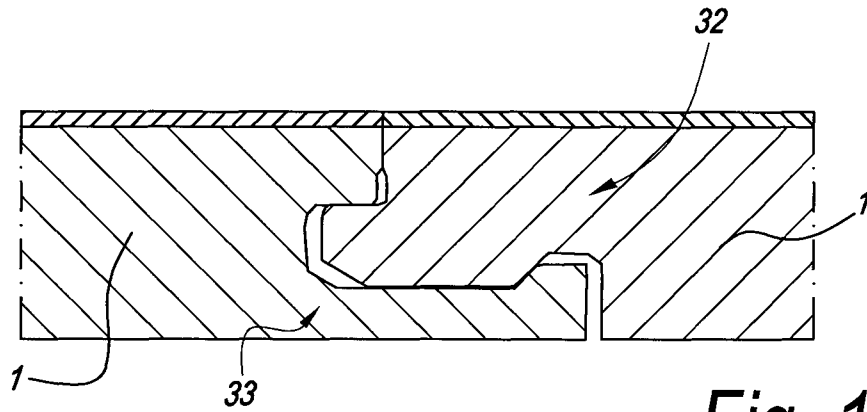

Fig. 17

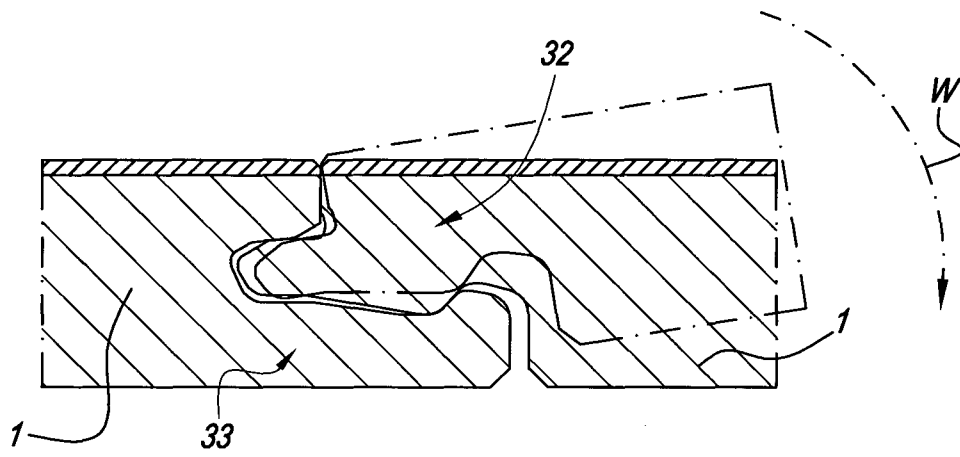

Fig. 18

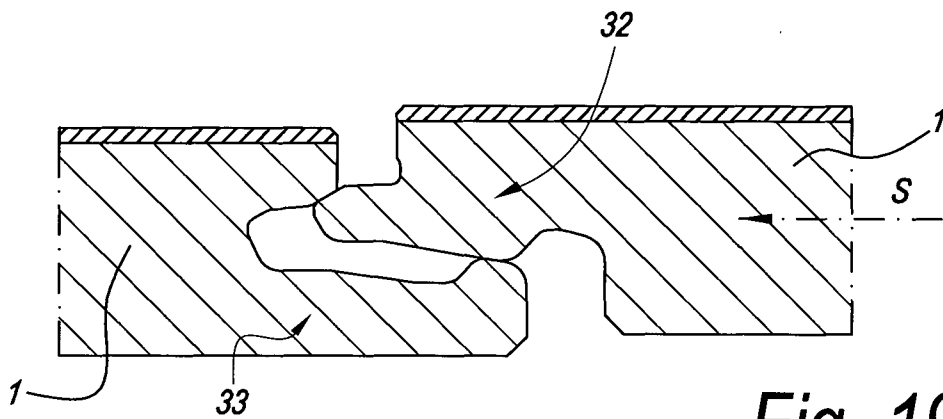

Fig. 19

INTERNATIONAL SEARCH REPORT

International application No
PCT/IB2015/057389

A. CLASSIFICATION OF SUBJECT MATTER INV. E04F15/10 ADD.		
According to International Patent Classification (IPC) or to both national classification and IPC		
B. FIELDS SEARCHED Minimum documentation searched (classification system followed by classification symbols) E04F		
Documentation searched other than minimum documentation to the extent that such documents are included in the fields searched		
Electronic data base consulted during the international search (name of data base and, where practicable, search terms used) EPO-Internal, WPI Data		
C. DOCUMENTS CONSIDERED TO BE RELEVANT		
Category*	Citation of document, with indication, where appropriate, of the relevant passages	Relevant to claim No.
X	WO 2014/033628 A1 (PERGO EUROP AB [SE]) 6 March 2014 (2014-03-06) paragraphs [0006], [0037], [0038], [0044], [0078] figures 1-5	1-59
X	----- US 2011/094178 A1 (BRAUN ROGER [CH]) 28 April 2011 (2011-04-28) paragraphs [0033], [0037] figures 1,2a-2d ----- -/--	1-4,49, 52,59
<input checked="" type="checkbox"/> Further documents are listed in the continuation of Box C. <input checked="" type="checkbox"/> See patent family annex.		
* Special categories of cited documents :		
"A" document defining the general state of the art which is not considered to be of particular relevance "E" earlier application or patent but published on or after the international filing date "L" document which may throw doubts on priority claim(s) or which is cited to establish the publication date of another citation or other special reason (as specified) "O" document referring to an oral disclosure, use, exhibition or other means "P" document published prior to the international filing date but later than the priority date claimed		"T" later document published after the international filing date or priority date and not in conflict with the application but cited to understand the principle or theory underlying the invention "X" document of particular relevance; the claimed invention cannot be considered novel or cannot be considered to involve an inventive step when the document is taken alone "Y" document of particular relevance; the claimed invention cannot be considered to involve an inventive step when the document is combined with one or more other such documents, such combination being obvious to a person skilled in the art "&" document member of the same patent family
Date of the actual completion of the international search 5 January 2016		Date of mailing of the international search report 12/01/2016
Name and mailing address of the ISA/ European Patent Office, P.B. 5818 Patentlaan 2 NL - 2280 HV Rijswijk Tel. (+31-70) 340-2040, Fax: (+31-70) 340-3016		Authorized officer Arsac England, Sally

INTERNATIONAL SEARCH REPORT

International application No

PCT/IB2015/057389

C(Continuation). DOCUMENTS CONSIDERED TO BE RELEVANT		
Category*	Citation of document, with indication, where appropriate, of the relevant passages	Relevant to claim No.
X A	WO 2014/108875 A1 (FLOORING IND LTD SARL [LU]) 17 July 2014 (2014-07-17) page 9, line 5 - line 7 page 10, line 32 - page 11, line 14 page 26, line 10 - line 19 page 33, line 34 - page 34, line 2 page 34, line 20 - line 22 page 38, line 17 - line 20 page 40, line 19 - line 22 page 43, line 13 - line 18 figures 1,2,5-7,33 -----	2,4,49, 52,59 1,3
X A	EP 2 339 092 A1 (FLOORING IND LTD SARL [LU]) 29 June 2011 (2011-06-29) cited in the application paragraphs [0026], [0037], [0059] figures 6-9 -----	2,49,52, 59 1,3,4
X A	EP 1 614 829 A2 (UNILIN BEHEER BV [NL]) 11 January 2006 (2006-01-11) paragraphs [0028], [0075], [0088] - [0093], [0100] figures 22-25 -----	49-51,59 1-48, 52-58
X,P A,P	WO 2015/130169 A1 (INNOVATIONS 4 FLOORING HOLDING N V) 3 September 2015 (2015-09-03) page 3, line 16 - line 28 page 14, line 4 - line 20 page 15, line 14 - line 20 page 16, line 26 - line 29 page 17, line 14 - line 21 page 20, line 6 - page 22, line 4 figures 1,3,4a,4b -----	2,4 1,3,49, 52
A	WO 2010/023042 A1 (AKZENTA PANELEE & PROFILE GMBH [DE]; HANNIG HANS-JUERGEN [DE]) 4 March 2010 (2010-03-04) cited in the application page 2, line 27 - page 3, line 3 figures 1,2a,2b -----	1-59

INTERNATIONAL SEARCH REPORT

Information on patent family members

International application No

PCT/IB2015/057389

Patent document cited in search report	Publication date	Patent family member(s)	Publication date
WO 2014033628 A1	06-03-2014	EP 2895667 A1 US 2015240500 A1 WO 2014033628 A1	22-07-2015 27-08-2015 06-03-2014
US 2011094178 A1	28-04-2011	AT 548528 T CA 2723913 A1 CA 2785051 A1 CN 102046899 A EP 2213812 A1 ES 2383934 T3 JP 5096617 B2 JP 2011528761 A PL 2213812 T3 RU 2010143283 A US 2011094178 A1 WO 2010086084 A1	15-03-2012 05-08-2010 05-08-2010 04-05-2011 04-08-2010 27-06-2012 12-12-2012 24-11-2011 31-07-2012 27-04-2012 28-04-2011 05-08-2010
WO 2014108875 A1	17-07-2014	CA 2895312 A1 CN 104968873 A EP 2946047 A1 KR 20150106918 A US 2015337542 A1 WO 2014108875 A1	17-07-2014 07-10-2015 25-11-2015 22-09-2015 26-11-2015 17-07-2014
EP 2339092 A1	29-06-2011	CA 2784227 A1 CN 102753772 A CN 104847083 A CN 104847084 A CN 104847085 A CN 104847086 A CN 104847087 A CN 104847088 A CN 104847089 A CN 104912293 A CN 104912294 A CN 104912295 A EP 2339092 A1 EP 2516768 A2 US 2012266555 A1 WO 2011077311 A2	30-06-2011 24-10-2012 19-08-2015 19-08-2015 19-08-2015 19-08-2015 19-08-2015 19-08-2015 19-08-2015 16-09-2015 16-09-2015 16-09-2015 29-06-2011 31-10-2012 25-10-2012 30-06-2011
EP 1614829 A2	11-01-2006	AR 008996 A1 AR 044640 A2 AR 060214 A2 AT 5566 U1 AT 196790 T AT 219812 T AT 246760 T AT 307249 T AT 419440 T AT 421623 T AT 445059 T AT 445750 T AT 461330 T AT 490384 T AT 501320 T AU 713628 B2 AU 752409 B2	08-03-2000 21-09-2005 04-06-2008 26-08-2002 15-10-2000 15-07-2002 15-08-2003 15-11-2005 15-01-2009 15-02-2009 15-10-2009 15-10-2009 15-04-2010 15-12-2010 15-03-2011 09-12-1999 19-09-2002

INTERNATIONAL SEARCH REPORT

Information on patent family members

International application No

PCT/IB2015/057389

Patent document cited in search report	Publication date	Patent family member(s)	Publication date
		AU 2002300410 B2	06-07-2006
		AU 2006201668 A1	18-05-2006
		AU 2006225242 A1	26-10-2006
		AU 2007201959 A1	24-05-2007
		AU 2010246529 A1	23-12-2010
		BE 1010487 A6	06-10-1998
		BG 62216 B1	31-05-1999
		BR 9702325 A	09-03-1999
		CA 2226286 A1	18-12-1997
		CA 2475076 A1	18-12-1997
		CA 2521949 A1	18-12-1997
		CA 2522085 A1	18-12-1997
		CA 2522092 A1	18-12-1997
		CA 2522130 A1	18-12-1997
		CA 2522141 A1	18-12-1997
		CA 2522321 A1	18-12-1997
		CA 2559357 A1	18-12-1997
		CA 2560527 A1	18-12-1997
		CA 2569612 A1	18-12-1997
		CA 2569614 A1	18-12-1997
		CA 2693267 A1	18-12-1997
		CA 2701554 A1	18-12-1997
		CA 2735317 A1	18-12-1997
		CA 2783398 A1	18-12-1997
		CL 2007001991 A1	30-05-2008
		CN 1195386 A	07-10-1998
		CN 1399051 A	26-02-2003
		CN 1572993 A	02-02-2005
		CN 1880702 A	20-12-2006
		CN 1880703 A	20-12-2006
		CN 1891951 A	10-01-2007
		CN 1928294 A	14-03-2007
		CN 1928295 A	14-03-2007
		CN 1928296 A	14-03-2007
		CN 1928297 A	14-03-2007
		CN 1932203 A	21-03-2007
		CN 1932204 A	21-03-2007
		CN 1932205 A	21-03-2007
		CN 1932206 A	21-03-2007
		CN 1932207 A	21-03-2007
		CN 1932208 A	21-03-2007
		CN 1932209 A	21-03-2007
		CN 1932210 A	21-03-2007
		CN 1982638 A	20-06-2007
		CN 101016797 A	15-08-2007
		CN 101078293 A	28-11-2007
		CN 101078294 A	28-11-2007
		CN 102051973 A	11-05-2011
		CZ 299093 B6	23-04-2008
		CZ 9800391 A3	12-08-1998
		DE 1024234 T1	06-09-2001
		DE 1026341 T1	05-07-2001
		DE 02076363 T1	30-09-2004
		DE 05075560 T1	29-12-2005
		DE 05075635 T1	15-12-2005
		DE 05076551 T1	09-03-2006
		DE 05077262 T1	14-08-2008
		DE 05077327 T1	30-11-2006

INTERNATIONAL SEARCH REPORT

Information on patent family members

International application No

PCT/IB2015/057389

Patent document cited in search report	Publication date	Patent family member(s)	Publication date
		DE 05077348 T1	30-11-2006
		DE 07024053 T1	31-07-2008
		DE 08020631 T1	25-02-2010
		DE 29710175 U1	14-08-1997
		DE 29724428 U1	05-04-2001
		DE 29724742 U1	03-07-2003
		DE 29724868 U1	13-01-2005
		DE 29724876 U1	27-01-2005
		DE 29724883 U1	07-04-2005
		DE 69703230 D1	09-11-2000
		DE 69703230 T2	01-03-2001
		DE 69713629 D1	01-08-2002
		DE 69713629 T2	06-02-2003
		DE 69724013 D1	11-09-2003
		DE 69724013 T2	09-06-2004
		DE 69734406 T2	06-07-2006
		DK 0843763 T3	29-01-2001
		DK 1024234 T3	14-10-2002
		DK 1026341 T3	24-11-2003
		DK 1223267 T3	20-02-2006
		DK 1338721 T3	15-02-2010
		DK 1541778 T3	01-03-2010
		DK 1541779 T3	31-05-2010
		DK 1589161 T3	16-03-2009
		DK 1612346 T3	27-06-2011
		DK 1614828 T3	08-09-2013
		DK 1614829 T3	16-03-2009
		DK 1898026 T3	16-09-2013
		DK 2031148 T3	23-09-2013
		DK 2031149 T3	14-02-2011
		DK 2077358 T3	14-10-2013
		EG 21186 A	31-12-2000
		EP 0843763 A1	27-05-1998
		EP 1024234 A2	02-08-2000
		EP 1026341 A2	09-08-2000
		EP 1223267 A2	17-07-2002
		EP 1338721 A2	27-08-2003
		EP 1541778 A1	15-06-2005
		EP 1541779 A1	15-06-2005
		EP 1589161 A2	26-10-2005
		EP 1612346 A2	04-01-2006
		EP 1614828 A2	11-01-2006
		EP 1614829 A2	11-01-2006
		EP 1898026 A2	12-03-2008
		EP 2031147 A2	04-03-2009
		EP 2031148 A2	04-03-2009
		EP 2031149 A2	04-03-2009
		EP 2077358 A2	08-07-2009
		EP 2116668 A1	11-11-2009
		EP 2275622 A2	19-01-2011
		EP 2275623 A2	19-01-2011
		EP 2280131 A2	02-02-2011
		EP 2280132 A2	02-02-2011
		EP 2280133 A2	02-02-2011
		EP 2280134 A2	02-02-2011
		EP 2280135 A2	02-02-2011
		ES 2152679 T3	01-02-2001
		ES 2153799 T1	16-03-2001

INTERNATIONAL SEARCH REPORT

Information on patent family members

International application No

PCT/IB2015/057389

Patent document cited in search report	Publication date	Patent family member(s)	Publication date
		ES 2153800 T1	16-03-2001
		ES 2220244 T1	16-12-2004
		ES 2246751 T1	01-03-2006
		ES 2246752 T1	01-03-2006
		ES 2247961 T1	16-03-2006
		ES 2300234 T1	16-06-2008
		ES 2306634 T1	16-11-2008
		ES 2321417 T3	05-06-2009
		ES 2333647 T3	25-02-2010
		ES 2429163 T3	13-11-2013
		ES 2429293 T3	14-11-2013
		ES 2429294 T3	14-11-2013
		GR 3034933 T3	28-02-2001
		HK 1016234 A1	22-11-2002
		HK 1050232 A1	09-09-2005
		HU 228451 B1	28-03-2013
		HU 9901996 A2	28-10-1999
		ID 17097 A	04-12-1997
		JP 3742658 B2	08-02-2006
		JP 4463745 B2	19-05-2010
		JP H11510869 A	21-09-1999
		JP 2006052641 A	23-02-2006
		KR 100430315 B1	04-08-2004
		MA 24198 A1	31-12-1997
		MY 125475 A	30-08-2006
		MY 128251 A	31-01-2007
		MY 138281 A	29-05-2009
		MY 141102 A	15-03-2010
		NO 980569 A	10-02-1998
		NO 20016048 A	10-02-1998
		NZ 329581 A	28-02-2000
		PL 324923 A1	22-06-1998
		PT 843763 E	30-03-2001
		PT 1024234 E	29-11-2002
		PT 1026341 E	31-12-2003
		PT 1338721 E	06-01-2010
		PT 1541778 E	07-01-2010
		PT 1541779 E	31-05-2010
		PT 1589161 E	06-03-2009
		PT 1612346 E	25-05-2011
		PT 1614828 E	01-10-2013
		PT 1614829 E	22-04-2009
		PT 1898026 E	21-10-2013
		PT 2031148 E	01-10-2013
		PT 2031149 E	03-03-2011
		PT 2077358 E	09-10-2013
		RO 119641 B1	28-01-2005
		RO 122418 B1	29-05-2009
		RO 122818 B1	26-02-2010
		RO 130356 A2	30-06-2015
		RU 2200809 C2	20-03-2003
		RU 2285777 C2	20-10-2006
		RU 2327019 C1	20-06-2008
		RU 2352738 C2	20-04-2009
		RU 2010150363 A	20-06-2012
		SI 9720009 A	31-08-1998
		SK 16398 A3	09-09-1998
		SK 287700 B6	06-06-2011

INTERNATIONAL SEARCH REPORT

Information on patent family members

International application No

PCT/IB2015/057389

Patent document cited in search report	Publication date	Patent family member(s)	Publication date
		TN SN97099 A1	01-09-2000
		TR 9800209 T1	22-06-1998
		US 6006486 A	28-12-1999
		US 6490836 B1	10-12-2002
		US 2003024200 A1	06-02-2003
		US 2003024201 A1	06-02-2003
		US 2003029115 A1	13-02-2003
		US 2003029116 A1	13-02-2003
		US 2003029117 A1	13-02-2003
		US 2005284075 A1	29-12-2005
		US 2005284076 A1	29-12-2005
		US 2006005499 A1	12-01-2006
		US 2006032177 A1	16-02-2006
		US 2006196138 A1	07-09-2006
		US 2006201095 A1	14-09-2006
		US 2006225370 A1	12-10-2006
		US 2006225377 A1	12-10-2006
		US 2006236630 A1	26-10-2006
		US 2006236631 A1	26-10-2006
		US 2006236632 A1	26-10-2006
		US 2006236633 A1	26-10-2006
		US 2006236634 A1	26-10-2006
		US 2006236635 A1	26-10-2006
		US 2006236636 A1	26-10-2006
		US 2006236637 A1	26-10-2006
		US 2006236638 A1	26-10-2006
		US 2006236643 A1	26-10-2006
		US 2006248829 A1	09-11-2006
		US 2006248830 A1	09-11-2006
		US 2006248831 A1	09-11-2006
		US 2006254183 A1	16-11-2006
		US 2006254184 A1	16-11-2006
		US 2006254185 A1	16-11-2006
		US 2006260249 A1	23-11-2006
		US 2006272263 A1	07-12-2006
		US 2007094986 A1	03-05-2007
		US 2007094987 A1	03-05-2007
		US 2007107360 A1	17-05-2007
		US 2007107363 A1	17-05-2007
		US 2007251188 A1	01-11-2007
		US 2008010928 A1	17-01-2008
		US 2008010929 A1	17-01-2008
		US 2008053027 A1	06-03-2008
		US 2008053028 A1	06-03-2008
		US 2008060309 A1	13-03-2008
		US 2008060310 A1	13-03-2008
		US 2008060311 A1	13-03-2008
		US 2008066416 A1	20-03-2008
		US 2010319292 A1	23-12-2010
		US 2011023405 A1	03-02-2011
		US 2013104487 A1	02-05-2013
		US 2014290174 A1	02-10-2014
		US 2015211238 A1	30-07-2015
		WO 9747834 A1	18-12-1997

WO 2015130169	A1	03-09-2015	NONE

WO 2010023042	A1	04-03-2010	CA 2734801 A1

INTERNATIONAL SEARCH REPORT

Information on patent family members

International application No

PCT/IB2015/057389

Patent document cited in search report	Publication date	Patent family member(s)	Publication date
		CN 102137978 A	27-07-2011
		DE 202008011589 U1	27-11-2008
		DK 2318613 T3	08-12-2014
		EP 2318613 A1	11-05-2011
		ES 2525471 T3	23-12-2014
		HK 1156992 A1	20-12-2013
		KR 20110055565 A	25-05-2011
		PT 2318613 E	12-12-2014
		RU 2011112392 A	10-10-2012
		US 2011138722 A1	16-06-2011
		WO 2010023042 A1	04-03-2010
