

(No Model.)

2 Sheets—Sheet 1.

H. P. HOLLAND. ROTARY ENGINE.

No. 502,818.

Patented Aug. 8, 1893.

Fig. 1.

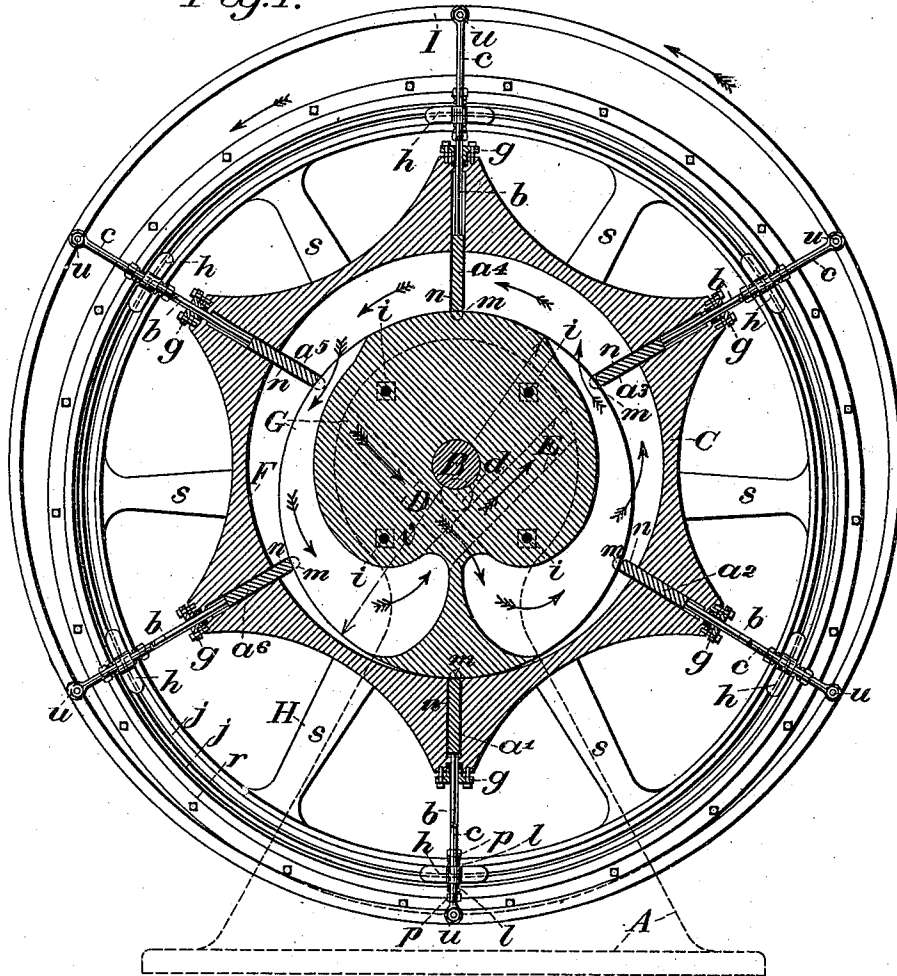
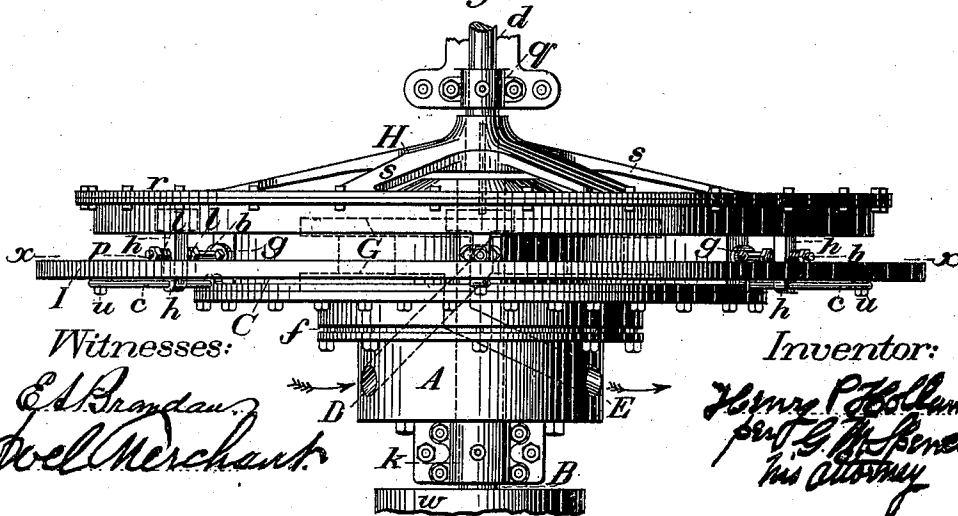

Fig. 2.



Witnesses:
Ed. Brandau
Joel Merchant

Inventor:
Henry P. Holland
per G. M. Spencer
his Attorney

H. P. HOLLAND.
ROTARY ENGINE.

No. 502,818.

Patented Aug. 8, 1893.

Fig. 3.

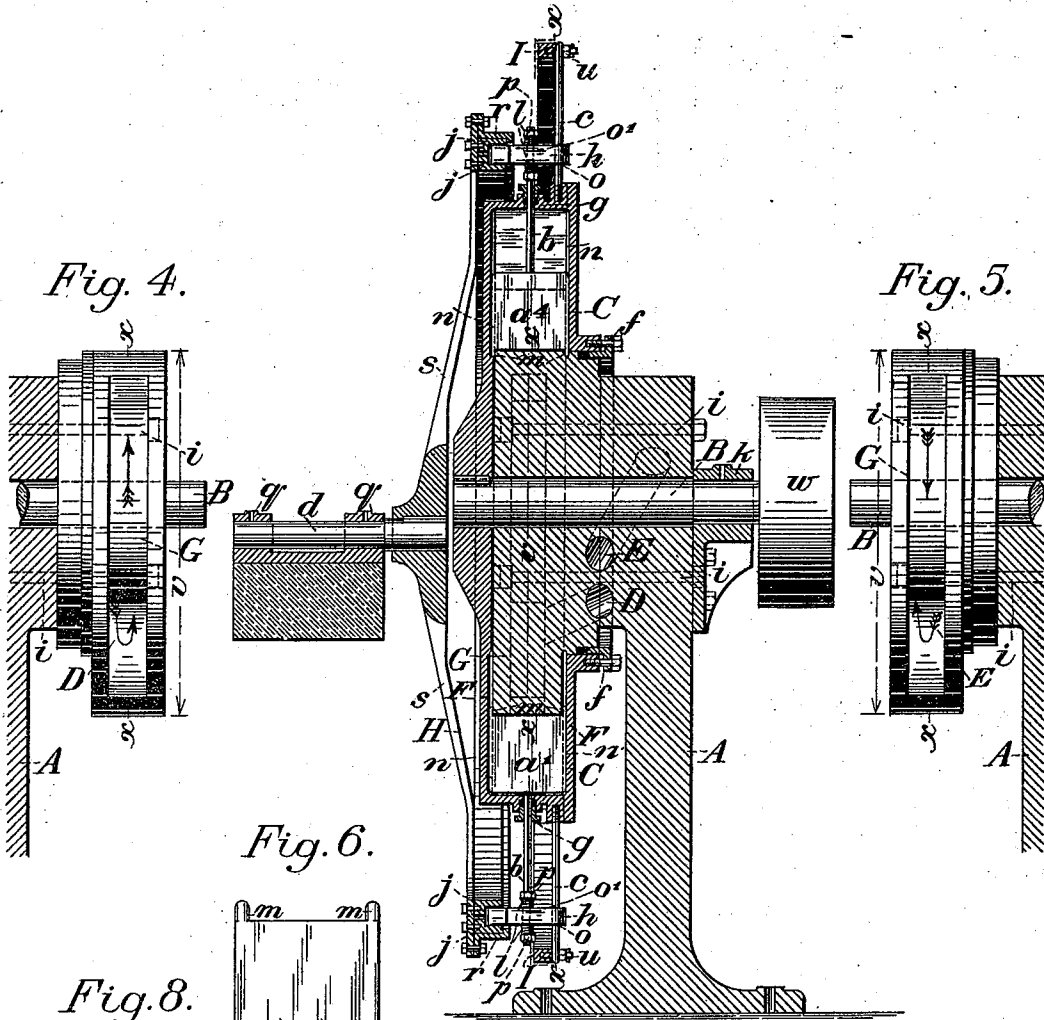

Fig. 4.

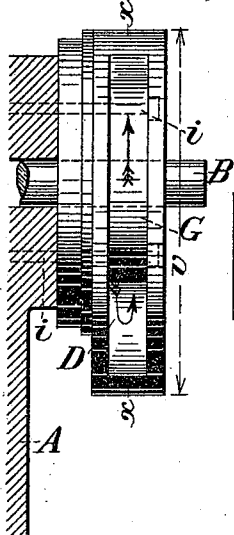

Fig. 5.

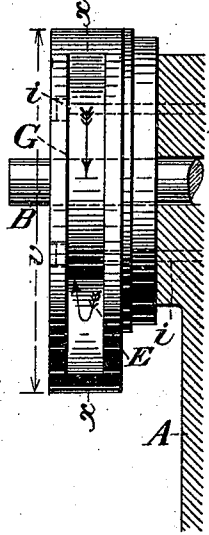

Fig. 6.

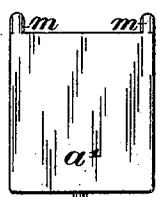

Fig. 8.

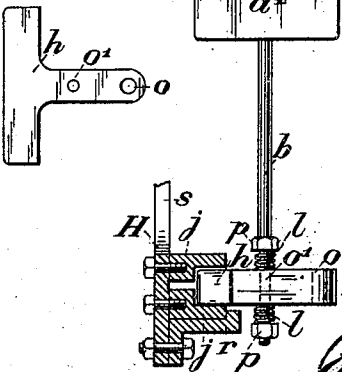

Fig. 7.



Witnesses:

Ed Brandau
Joel Merchant

Inventor:

H. P. Holland
Per S. McSpencer
his Attorney

UNITED STATES PATENT OFFICE.

HENRY P. HOLLAND, OF SAN FRANCISCO, CALIFORNIA.

ROTARY ENGINE.

SPECIFICATION forming part of Letters Patent No. 502,818, dated August 8, 1893.

Application filed September 24, 1892. Serial No. 446,846. (No model.)

To all whom it may concern:

Be it known that I, HENRY P. HOLLAND, of San Francisco, county of San Francisco, and State of California, have invented a certain new and useful Improvement in Rotary Engines, of which the following is a specification.

My invention relates to improvements in rotary engines by the application of the power as a continuous uninterrupted force, bearing directly upon the pistons, acting thereupon without any break or check of the same to produce thereby a steady and rapid revolution of the engine, by means of which, machinery may be operated so as to save a large percentage of the power that is now lost in all other methods of its application. There is absolutely no cut off or break of the force acting upon the pistons of the engine. Hence a much less force is required to accomplish the same results than by any other device now in use. The engine may be operated most effectively by steam, water, compressed air, and gas, and may be used as an air compressor or water pump. The motive power employed enters the port inlet of the revolving cylinder, and escapes, (after acting upon the pistons that slide therein) by the exhaust port, operating with a direct and continuous push in its rotary circular movement, and with the full degree of volume of power applied. The power acts in combination with the centrifugal force produced by the rapid revolution of the cylinder or engine, to propel the same.

I attain the objects of my invention by the mechanism illustrated in the accompanying drawings, in which—

Figure 1,—shows a transverse section of rotary engine on the line *x. x.* as seen in Fig. 3; Fig. 2,—a plan of rotary engine; Fig. 3,—a longitudinal section; Fig. 4,—view of port inlet or cylinder; Fig. 5,—view of exhaust port to cylinder; Fig. 6,—a detailed view of piston slide and slide rings; Fig. 7,—top view of piston; Fig. 8,—top view of slide.

The rotating engine consists of shaft B. mounted in the bed piece A. and carrying at its end a cylinder C. revolved by steam, water, air, gas or other power employed, passing into it through inlet port D, and out of it through exhaust port E, after acting upon the

pistons that slide in and out of said cylinder; and having the spider wheel H. fastened on small shaft *d.* being out of line with the main shaft, with arms *s. s.* attached at their outer ends to the rotating ring slides or cam-way *j. j.* said spider wheel with the said rotating ring slides acts as an eccentric with said main shaft, and is revolved by it. The slides or cam-way *h.* are inclosed in ring slides or cam-way *j. j.* and contain opening *o'* through which the ends of the piston rods *b. b.* pass and are fastened to it by nuts *p. p.* and by means of this connection of the piston rods with the rotating ring slides or cam-way the pistons *a' a² a³ a⁴ a⁵ a⁶* are moved in and out in the cylinder C, as the shaft B, and the cylinder revolve. Through the opening *o.* in the slides *h.* the guiding rods *c. c.* attached to, and governing the ring slides or cam-way and rotating them evenly pass, and are joined to the outer ring I; springs *e. e.* are placed on the ends of the piston rods on each side of slides *h. h.* secured in place by nuts *p. p.*; *m. m.* projections to piston pieces extending upward on same and moving in grooves *n. n.*; *q. q.* bearings for small shaft; *r.* flange to spider wheel; *u. u.* bolts fastening ends of guiding rods to outer ring, *i. i. i.* bolts that fasten bed pieces and support an inside cylinder wall together; *f.* packed joint in the cylinder for closing it tightly to prevent the escape of steam, air or gas, &c.; *g.* packing box in the cylinder where the pistons slide. *x. x.* show line of transverse section of engine, *w.* driving pulley; F. rotating wall of cylinder; G. fixed wall of cylinder; *v.* outer circumference of cylinder; *k.* bearings to main shaft. The steam or motive power employed entering the inlet port of the cylinder strikes against the pistons *a² a³* partly closed, and *a⁴* wholly closed, revolving the engine rapidly, and as the pistons *a⁵* and *a⁶* partly closed (as shown in the drawings) rise by the action of the ring slides to which the ends of the piston rods are attached, escapes through the exhaust port, and by the rapid revolutions of the engine the steam, water, or power employed is hurled against the outer circumference wall of the cylinder, and against the pistons so as to add force, and greatly to accelerate the speed of the engine, thus operating it by the power and centrifugal force combined.

The small shaft with the spider wheel acts as an eccentric with the main shaft and cylinder and operates the ring slides that work the pistons on the guiding rods, rotating said slides evenly. The driving pulley *w.* attached to main shaft operates the machinery with which it is connected by belts or other connection. The springs on each side of slides *h. h.* act to prevent rigidity of the action of the pistons, so as to enable them to give passage for any obstructions that might enter the cylinder and be forced against them.

The inner and outer ring slides inclosing slides *h. h.* are retained in place by means of bolts. *s. s.* are arms of spider wheel attached at the outer ends to the ring slides. The guiding rods to the pistons are attached at their outer ends to the outside ring and are secured at their other or lower ends to the outside of the cylinder near the packing box.

What I claim as my invention, and desire to secure by Letters Patent of the United States, is—

1. A rotary engine consisting of shaft B. with driving pulley *w.* mounted in the bed piece A. and carrying at its end a cylinder C. with inlet port D. and exhaust port E. having the spider wheel H. fastened on small shaft *d.* operating as an eccentric with main shaft B. with arms *s. s.* attached at their outer ends to rotating ring slides or cam-way *j. j.* which inclose slides *h.* to which the piston rods *b. b.* are fastened for moving the pistons in and out as the engine revolves and through which the guiding rods pass and are joined to the outer ring I, the springs *b. b.*; the packed joint *f.*, and packed box *g.*, substantially as herein described.

2. In a rotary engine, the combinations of the shaft B., the cylinder C. (formed by rotating wall F., fixed wall G. and circumference wall *v.*) mounted on bed piece A. the pistons *a' a² a³ a⁴ a⁵ a⁶* for sliding in and out of the cylinder, upon which the power employed acts for rotating the engine, the piston rods *b. b.* fastened in slides *h.* in the opening *o'*, the guiding rods *c. c.* passing through opening *o*, in slides *h.* and joined at their ends to the outer ring I; with the spider wheel H, attached to small shaft *d.*, rotated by and working as an eccentric with main shaft B., the arms of which are joined at their outer ends to rotating ring slides or cam-way *j. j.*, which inclose the slides *h.* to which the piston rods are joined, and by means of which the pistons are moved in and out as the power employed for propelling the engine passes into and

through the cylinder, substantially as herein described.

3. In a rotary engine the combination of the inlet and exhaust ports D. and E. with the pistons *a' a² a³ a⁴ a⁵ a⁶* sliding in and out of the cylinder C. as the main shaft B. revolves and rotates the cylinder, the piston rods *b. b.* the slides *h.* guiding rods *c. c.* outer ring I, the rotating ring slides or cam-way *j. j.*, the spider wheel H on small shaft *d.* having arms *s. s.* attached to and rotating the ring slides by means of which said pistons are operated in the cylinder so that the power employed to rotate the engine may act upon them and be set free to escape, substantially as herein described.

4. In a rotary engine the combination of the spider wheel H. attached to small shaft *d.* having arms *s. s.* fastened at their outer ends to rotating ring slides or cam-way *j. j.*, operated as an eccentric with main shaft B. and cylinder C., with the pistons *a' a² a³ a⁴ a⁵ a⁶* piston rods *b. b.*, slides *h.*, inclosed in said rotating ring slides, or cam-way the guiding rods *c. c.* and outer ring I. moved and operated by steam, water, compressed air, gas or other power passing into and out of inlet and exhaust ports D. and E. through cylinder C., substantially as herein described and set forth.

5. In a rotary engine the combination of the pistons *a' a² a³ a⁴ a⁵ a⁶* in a cylinder as C. mounted on a shaft as B., the piston rods *b. b.* inclosing slides *h.*, rotating rings or cam-way *j. j.*, with a spider wheel fastened upon small shaft *d.* outside of the cylinder operating said pistons and rotating rings slides or cam-way moved and carried by the revolutions of shaft B. when the steam or other power employed is admitted to and passes through and out of the cylinder C. through inlet and exhaust ports D. and E., substantially as herein described and set forth.

6. In a rotary engine the combination of the outer ring I, to which the ends of the guiding rods are joined; the guiding rods *c. c.* and slides *h.*, with the cylinder C., main shaft B., for the purpose of operating and carrying the spider wheel H. on small shaft *d.*, the arms of which are attached to rotating rings or cam-way *j. j.* inclosing slides *h.*, to which piston rods *a' a² a³ a⁴ a⁵ a⁶* are attached, thereby moving them in and out as the shaft B. revolves, substantially as herein described.

HENRY P. HOLLAND.

Witnesses:

JAMES JOYES,

GEORGE WASHINGTON TOWLE, Jr.