



US 20050241248A1

(19) **United States**

(12) **Patent Application Publication**
Ridenour

(10) **Pub. No.: US 2005/0241248 A1**

(43) **Pub. Date: Nov. 3, 2005**

(54) **RIDGE CAP CLOSURE SYSTEM**

Publication Classification

(75) **Inventor: Randall D. Ridenour, Mansfield, OH (US)**

(51) **Int. Cl.⁷ E04D 3/36**

(52) **U.S. Cl. 52/198**

Correspondence Address:
Thomas W. Ryan
PIPER RUDNICK LLP
P.O. Box 64807
Chicago, IL 60664-0807 (US)

(57) **ABSTRACT**

A roof closure system for use with corrugated panel roofs having a ridge cap and ventilated or non-ventilated foam closures permanently attached thereto, the ridge cap and the foam assembled as a ready-to-use single unit. The foam closure is formed a highly malleable foam material such that the closure may be used with any style of corrugated metal roof panels.

(73) **Assignee: ATLAS BOLT & SCREW CO.**

(21) **Appl. No.: 10/695,041**

(22) **Filed: Oct. 28, 2003**

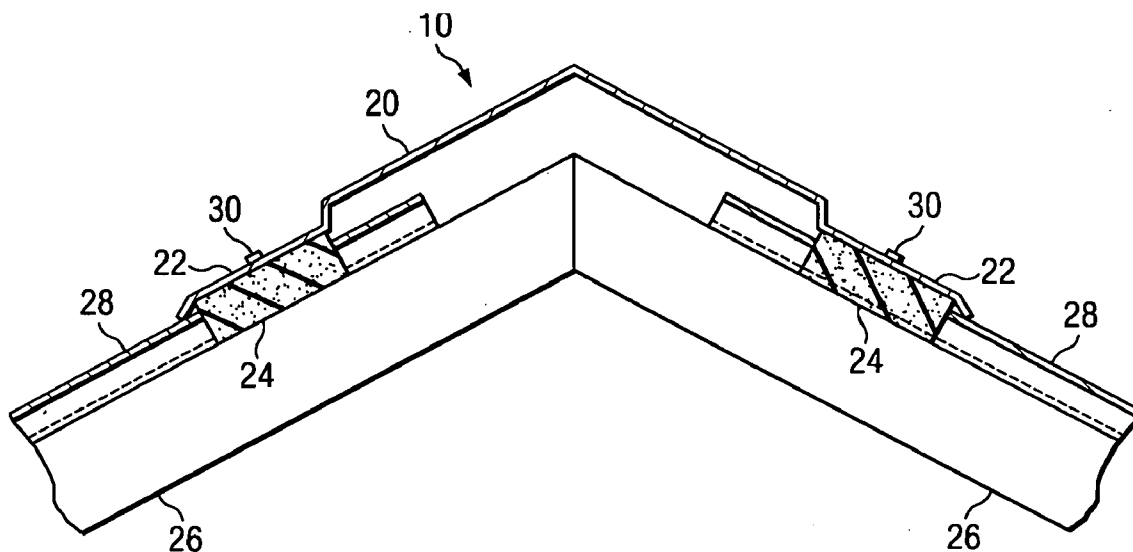

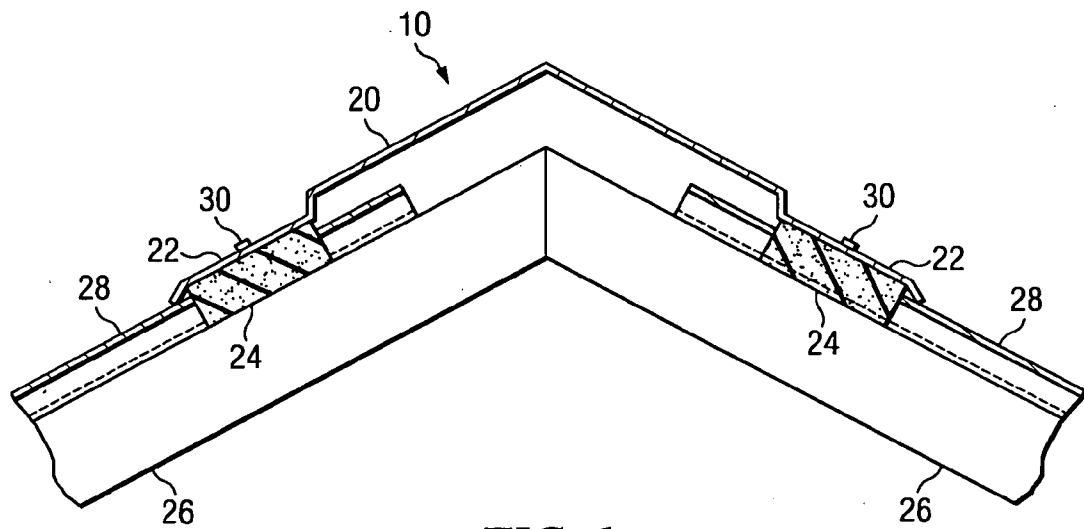

FIG. 1

RIDGE CAP CLOSURE SYSTEM

BACKGROUND OF THE INVENTION

[0001] 1. Field of Invention

[0002] This invention finds use in the field of ridge or roof caps for freestanding structures. More particularly, this invention relates to a ridge or roof cap for structures having corrugated metal roofs and vented or non-vented foam closures.

[0003] 2. Background

[0004] Many types of freestanding structures, particularly commercial buildings, are constructed with roofs formed from corrugated metal panels or sheets. In a building having a peaked or pitched roof, as opposed to a flat roof, a roof or ridge cap is placed at the peak. Depending on the requirements of the building, the ridge cap may serve to assist ventilation in the building in combination with ridge vents in the eaves.

[0005] By its very nature, the surface of a corrugated metal panel has a series of repeating troughs and crests. When an object, such as the flat attachment portions of a ridge cap are placed on top of such troughs and crests, gaps are formed between the object and the corrugated metal panel. Such gaps are not welcome due to issues of insulation, moisture weathering, and wear from debris collecting in the gaps. It is therefore custom practice to place a strip of foam between the ridge cap attachment portions (flaps) and the corrugated roof panels. The foam is usually contoured on one side to the pattern of the corrugated roof panel and contains an adhesive backing. At the construction site, the adhesive backing on the foam is exposed and the foam is attached to the roof panels. The ridge cap is lined up with the foam closure on the corrugated roof and fastened using conventional means known in the art such as screw, nails, or bolts.

[0006] While there is no doubt that prior art foam closure systems are functional, they present several usability problems which can interfere with an otherwise smooth installation in the field. The adhesive backing can sometimes be difficult to expose and, upon exposure, can pick up dirt, dust and other debris from the job site, leading to problems with adhesion and possible premature wear of the foam or the ridge cap. It can also be difficult to line up the exposed adhesive portions of the foam with the roof panels, leading to possible waste of materials and manpower to correct misaligned pieces of foam. Finally requiring corrugated metal panels, foam closures needing to correspond to the shape of the corrugations, and ridge caps, all possibly from separate manufacturers, complicates the ordering and delivery process and leads to clutter on the job site

[0007] It is therefore an object of the present invention to provide a roof ridge cap and foam closure that is easy and economical to install in the field.

[0008] It is another object of the present invention to provide a roof ridge cap and foam enclosure that reduced the likelihood of collecting unwanted dust, dirt and debris.

[0009] It is yet another object of the present invention to provide a foam closure that is able to mate to a wide variety of corrugation styles of metal roof panels so as not to be profile sensitive.

[0010] These and other objects of the invention will be apparent to those skilled in the art for the following detailed description of the preferred embodiments of the invention.

SUMMARY OF INVENTION

[0011] The invention comprises roof closure system for use with corrugated panel roofs having a a ridge cap and ventilated or non-ventilated foam closures permanently attached thereto, manufactured as a single unit. In the preferred embodiment of the invention, the foam closure is formed a highly malleable foam material such that the closure may be used with any style of corrugated metal roof panels. It is also contemplated that the foam closures attached to the ridge caps may be formed of a shaped foam that corresponds to a particular pattern or style of a corrugated metal roof panel.

BRIEF DESCRIPTION OF THE DRAWING

[0012] Specific embodiments of the invention have been chosen for purposes of illustration and description, and are shown in the accompanying drawing, forming a part of the specification wherein:

[0013] **FIG. 1** is a cross-sectional view of the inventive ridge cap closure system on a metal paneled roof.

DESCRIPTION OF PREFERRED EMBODIMENTS

[0014] The ridge cap closure system according to the present invention will be described herein by reference to the accompanying drawing wherein **FIG. 1** shows a cross-sectional view of of the inventive ridge cap closure system on a metal paneled roof.

[0015] As described in further detail, below, the subject ridge cap closure system **10** is generally comprised of a ridge cap **20** having two or more dependant ledges **22** runing the entire length of both sides of the ridge cap and foam closure strips **24** attached to each of said dependant ledges **22**. The ridge cap **20** portion of closure system **10** is constructed of metal conventionally used in metal panel roof buildings, such as galvanized steel, aluminum or copper and is available pre-formed from numerous suppliers or can be bent in situ during the manufacturing process of the entire closure system **10**. As shown in **FIG. 1**, the ridge cap **20** generally is formed in a triangular or peaked shape although a rounded or flatened shape may used, as dictated by the project. Ridge caps normally sold and used in **10'** sections.

[0016] In the preferred embodiment of the invention, the foam closure strips **24** are generally formed from a flexible, semi-rigid, cross-linked polyethylene foam, such as is produced by Hibco Plastics, Inc. (Yadkinville, N.C.) or any other foam material used in the art. Depending on the building application, the foam closures **24** can be non-ventilating or ventilating, closed or open-celled. In the preferred embodiment of the invention, the foam closure **24** is formed in a convoluted, egg-crate style and is highly mailable, such that it can conform to any pattern of corrugation of the corrugated roof panels **28**. One advantage of using a mailable foam closure **24** over the prior art is that a contractor need only be concerned about ordering the closure system **10** having the appropriate type of ridge cap **20** and not being concerned with ordering the appropriate type

of contoured foam to match the style of corrugated panels being used on the building project. Further, malleable foam **24**, as used as part of the inventive system **10**, offers the added advantage of being able to use different corrugation styles of corrugated panel **28** on the same roof with a continuous strip of foam **24**. Of course, the closure system **10** of the instant invention functions, albeit less preferably, using specifically contoured foam matching the contours of the specific corrugated panel **28**, as is currently practiced in the art.

[0017] The inventive closure system **10** is formed at a factory or other manufacturing facility as a single component rather than a ridge cap **20** and foam strips **24** separately ordered and transported to a construction site and assembled by workers exposing an adhesive backing the foam **24** and adhering the foam to the roof panels. The closure system **10** may be formed as part of a unitary assembly process where the ridge cap **20** and the foam are assembled on the same line with automated means, such as a manufacturing line, or otherwise with minimal human intervention. In an alternative embodiment of the assembly process, the ridge cap **20** and the foam **24** are manufactured in separate facilities, possibly by unrelated manufacturers, brought together at another manufacturing line, an adhesive is applied to the back of the foam **24** which is then precisely mated to the ridge cap **20**. In either manufacturing embodiment, the complete closure system **10** is then ready to be transported to a construction site and used, without concern of lining up the foam **24** with the roof panels **28** and subsequently lining up the cap **20** with the roof panels **28** and the foam **24**.

[0018] Referring again to FIG. 1, a building roof is formed of a series of beams or struts **26**, two of which are shown in the cut-away view. A series of corrugated panels **28**, typically metal, are affixed to and between the struts **26**. The closure system **10** is placed upon the metal panels **28** such that the peak of the ridge cap **20** is aligned with the peak of the roof. The closure system is then attached to the metal panels **28** and the struts **26** by way of fastening means **30** such as screws, bolts, nails, and rivets. Upon attachment, the malleable foam **24** conforms to and fills the various troughs and crests of the corrugated panels **28**, forming a tight seal between the ridge cap **20** and the roof panels **28**.

[0019] In addition to the use with ridge caps **20**, the instant invention is adaptable to base plates and eave struts. It should also be noted that the foam may be placed underneath the ridge cap **20** or on top of the base plates or eave struts, depending on the needs of the contractor.

[0020] In addition to the structures, sequences, and uses immediately described above, it will be apparent to those skilled in the art that other modifications and variations can be made the method of the instant invention without diverging from the scope, spirit, or teaching of the invention. Therefore, it is the intention of the inventors that the description of instant invention should be considered illustrative and the invention is to be limited only as specified in the claims and equivalents thereto.

I claim:

- 1. A pre-assembled closure system for a corrugated roof, the closure system comprising a ridge cap having a plurality of dependent ledges, each of said dependent ledges having a foam closure permanently attached thereto.
- 2. The pre-assembled closure system of claim 1 wherein the foam closure is formed of a malleable foam material whereby the foam closure can conform to a wide variety of patterns of corrugated panels.
- 3. The pre-assembled closure system of claim 1 wherein the foam closure is selected from the group comprising ventilating foams and non-ventilating foams.
- 4. A manufacturing method of forming a pre-assembled closure system, the method comprising:
 - a) forming a ridge cap for a peaked corrugated roof building, said ridge cap having a plurality of dependant ledges;
 - b) permanently attaching a foam closure to said ridge cap, wherein said attachment is undertaken by automated means.
- 5. The method of claim 5 wherein forming the ridge cap and attaching the foam closure are undertaken concurrently on a manufacturing line.

* * * * *