



US00D517992S

(12) **United States Design Patent**
Riku

(10) **Patent No.:** **US D517,992 S**

(45) **Date of Patent:** **** *Mar. 28, 2006**

(54) **ELECTRICAL CONNECTOR**

(75) Inventor: **Kazuya Riku**, Tokyo (JP)

(73) Assignee: **Tyco Electronics AMP K.K.**,
Kanagawa-ken (JP)

(*) Notice: This patent is subject to a terminal disclaimer.

(**) Term: **14 Years**

(21) Appl. No.: **29/219,303**

(22) Filed: **Dec. 14, 2004**

(30) **Foreign Application Priority Data**

Jun. 15, 2004 (JP) 2004-017851

(51) **LOC (8) Cl.** **13-03**

(52) **U.S. Cl.** **D13/147**

(58) **Field of Classification Search** D13/133,
D13/184, 154, 199, 146-147; 439/79, 101,
439/108, 344, 350, 352, 447, 557, 571, 573,
439/540.1, 541.5, 607-608, 825

See application file for complete search history.

(56) **References Cited**

U.S. PATENT DOCUMENTS

- 5,139,426 A * 8/1992 Barkus et al. 439/65
- 5,403,206 A * 4/1995 McNamara et al. 439/608
- 5,582,519 A * 12/1996 Buchter 439/101
- 5,667,392 A * 9/1997 Kocher et al. 439/79

- D449,821 S * 10/2001 Shimojyo D13/147
- 6,319,075 B1 11/2001 Clark et al.
- D453,735 S * 2/2002 Yoneyama et al. D13/147
- D462,057 S * 8/2002 Okamoto D13/147
- 6,431,886 B1 * 8/2002 Ramey et al. 439/101
- 2002/0034891 A1 * 3/2002 Laurer et al. 439/488
- 2003/0087556 A1 * 5/2003 Korsunsky et al. 439/626

* cited by examiner

Primary Examiner—Stella Reid

Assistant Examiner—Daniel Bui

(74) *Attorney, Agent, or Firm*—Barley Snyder LLC

(57) **CLAIM**

The ornamental design for an electrical connector, as shown and described.

DESCRIPTION

FIG. 1 is a front elevation view of an electrical connector, showing my new design;
 FIG. 2 is a top plan view thereof;
 FIG. 3 is a bottom plan view thereof;
 FIG. 4 is a right side elevation view thereof;
 FIG. 5 is a left side elevation view thereof;
 FIG. 6 is a rear elevation view thereof;
 FIG. 7 is a cross sectional view thereof, taken along the line 7—7 in FIG. 1;
 FIG. 8 is a cross sectional view thereof, taken along the line 8—8 in FIG. 1; and,
 FIG. 9 is a top, front and right side perspective view thereof.

1 Claim, 9 Drawing Sheets

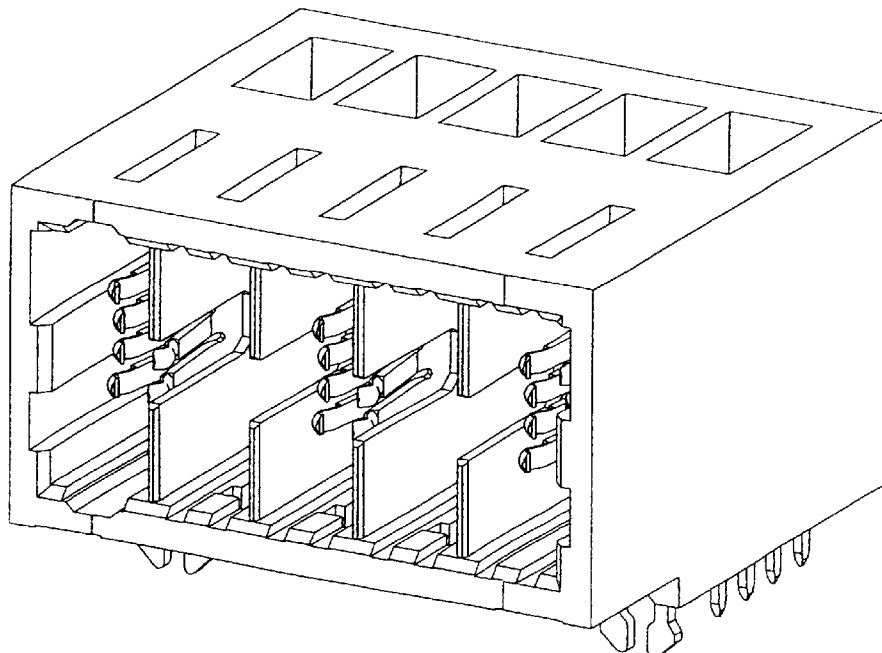

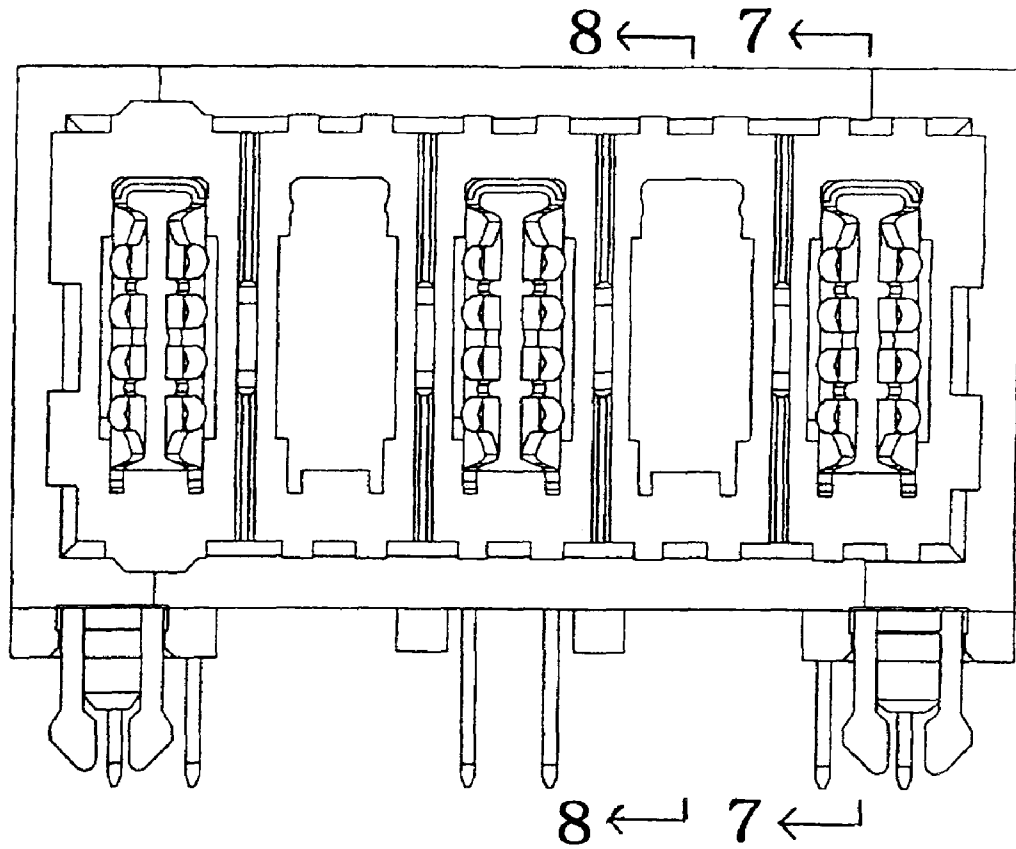

FIG. 1

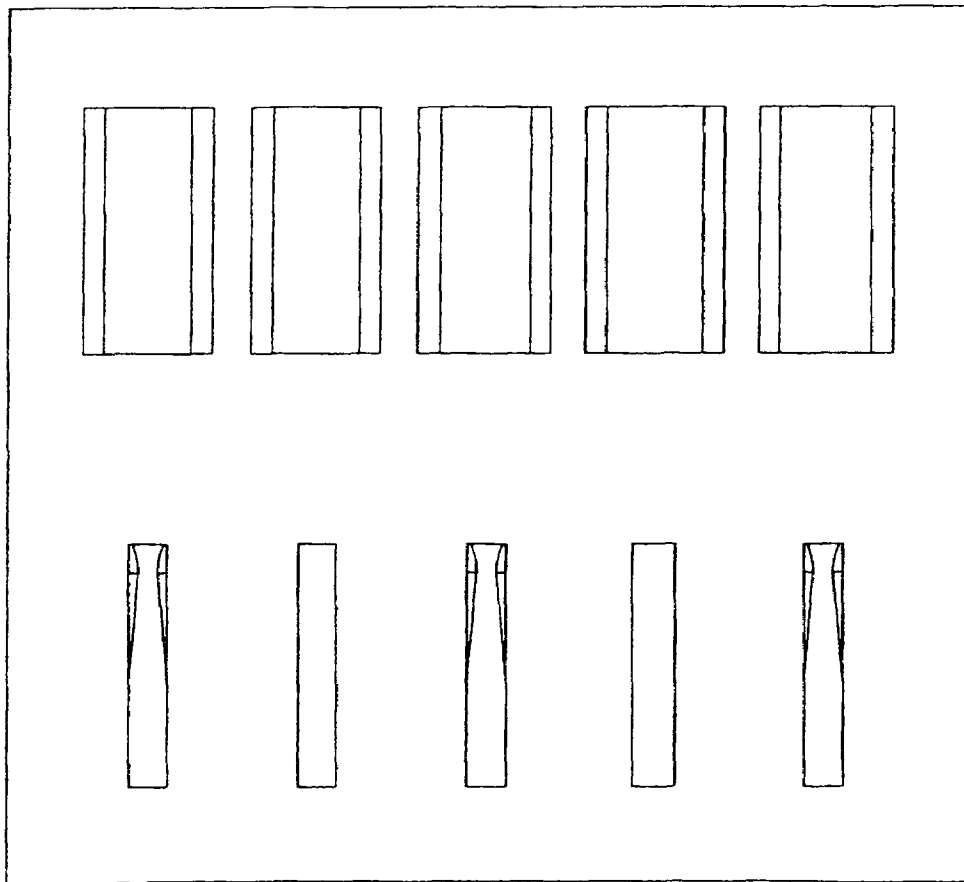

FIG. 2

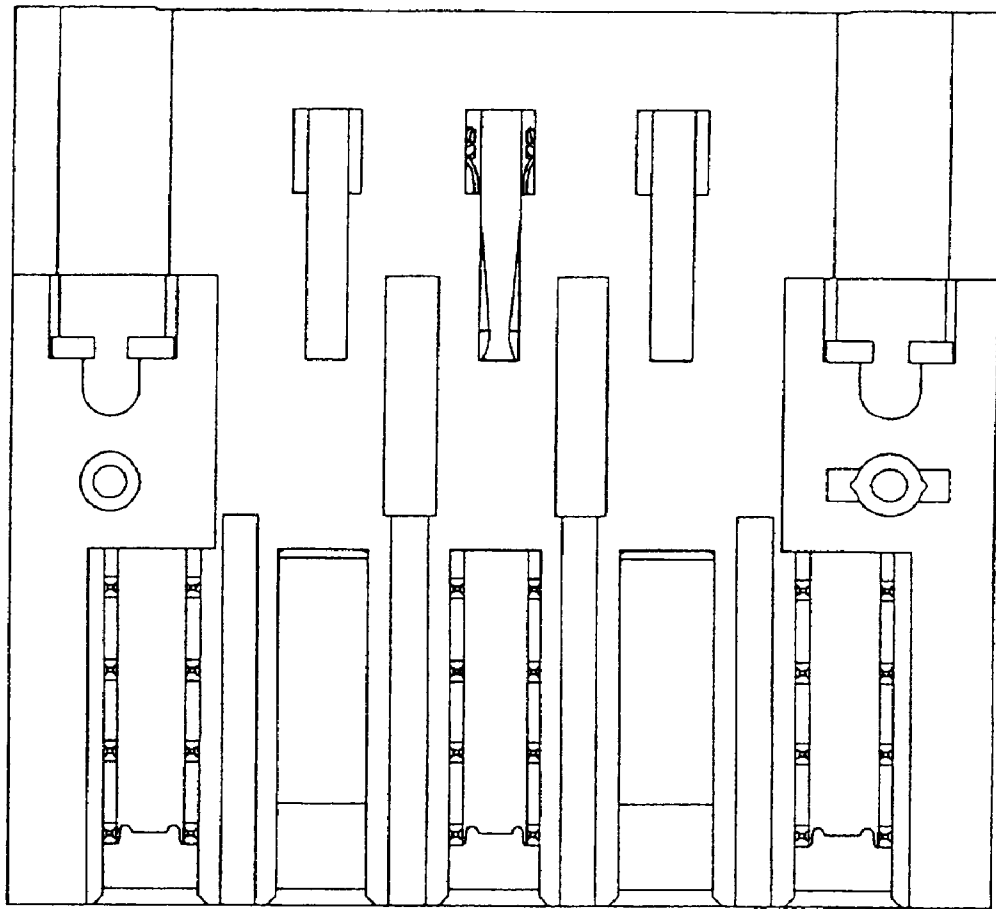

FIG. 3

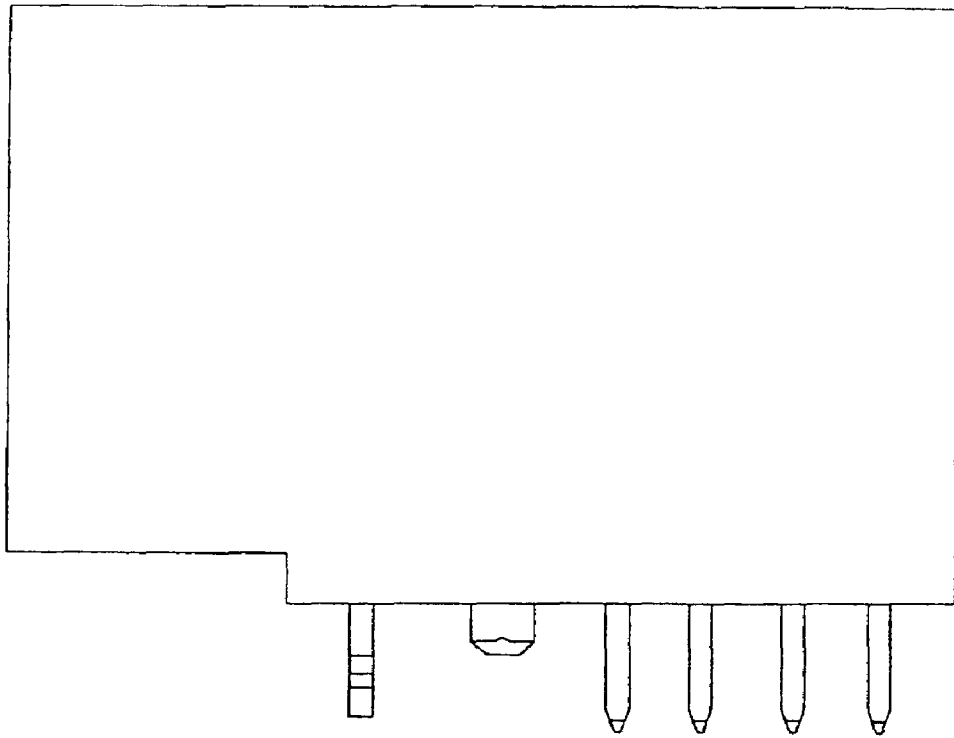

FIG. 4

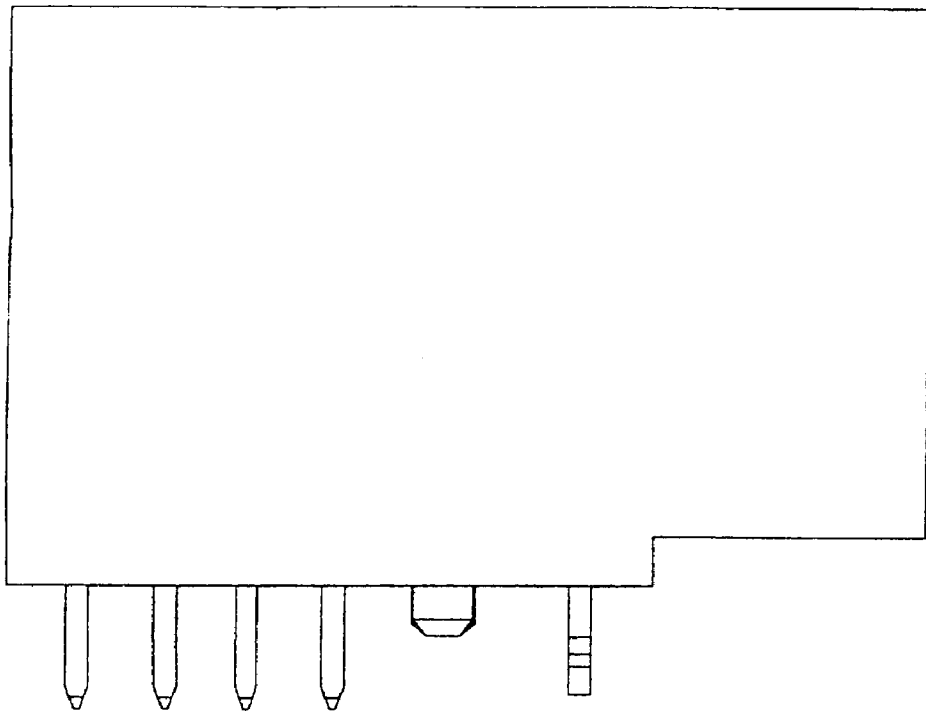

FIG. 5

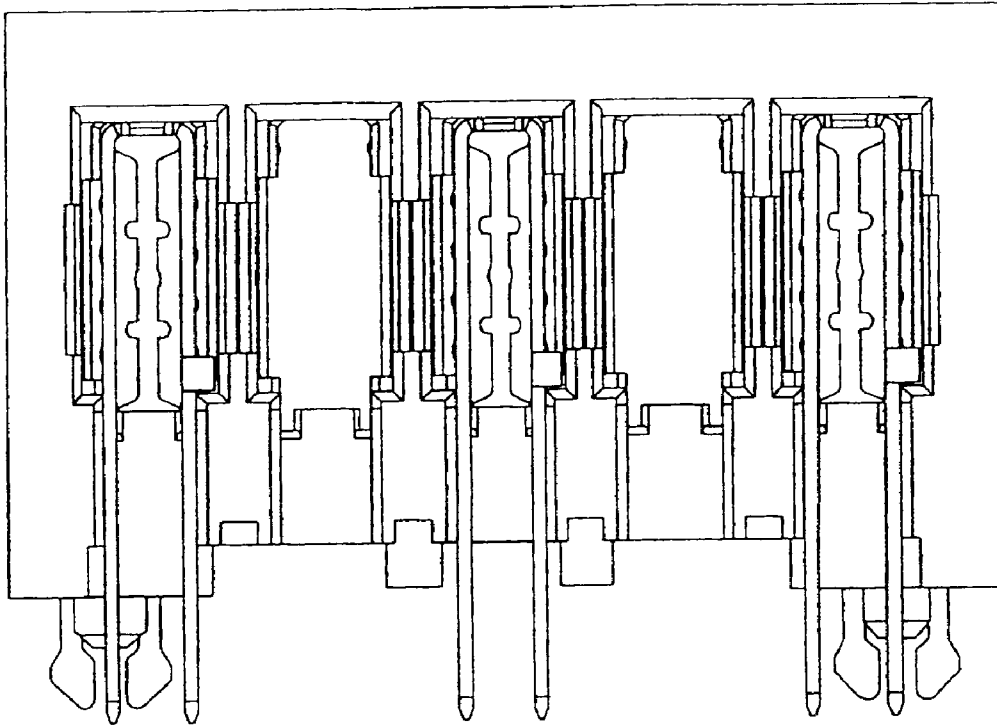

FIG. 6

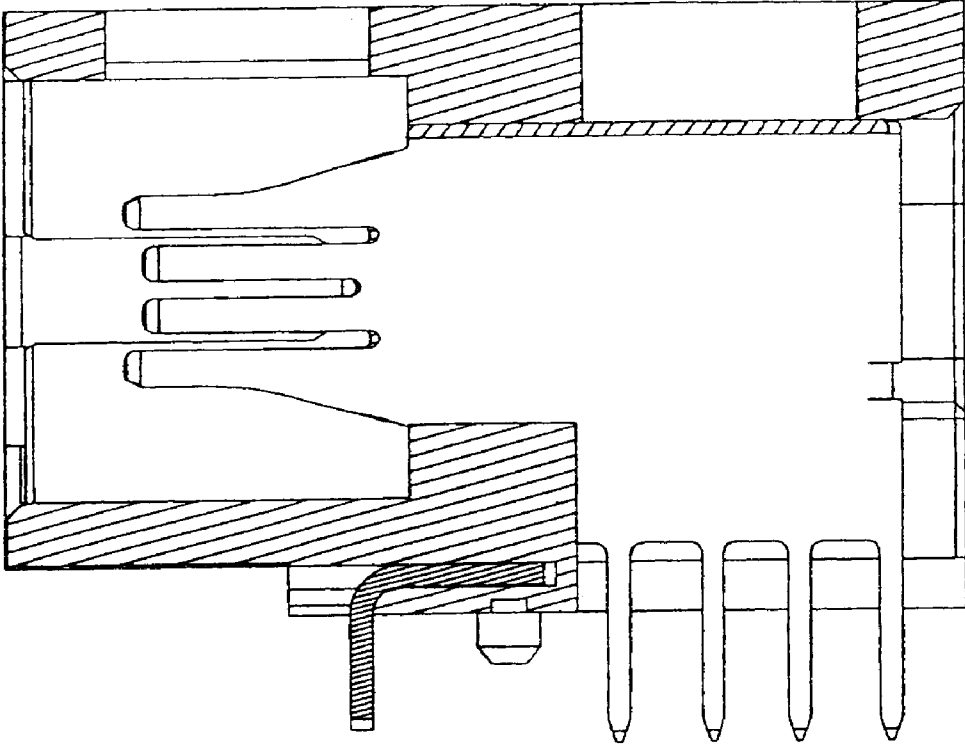

FIG. 7

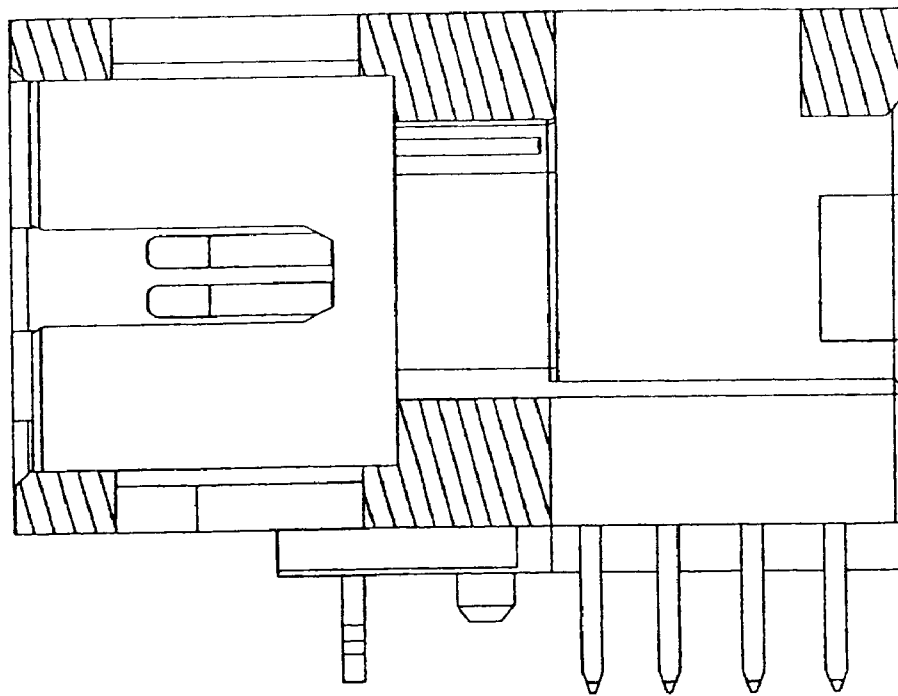

FIG. 8

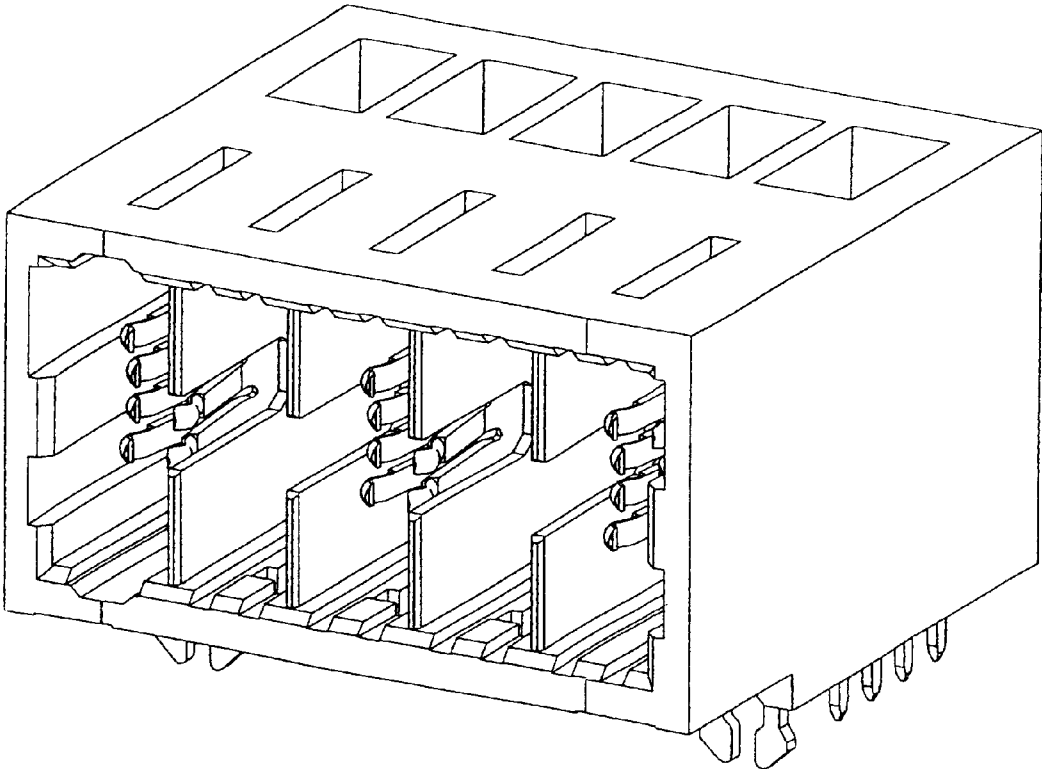

FIG. 9