



US00D787648S

(12) **United States Design Patent**  
**Smith**

(10) **Patent No.:** **US D787,648 S**

(45) **Date of Patent:** **\*\* May 23, 2017**

- (54) **RAINTIGHT FITTING CONNECTOR BODY**
- (71) Applicant: **Bridgeport Fittings, Inc.**, Stratford, CT (US)
- (72) Inventor: **Lawrence J. Smith**, Stamford, CT (US)
- (73) Assignee: **BRIDGEPORT FITTINGS, INC.**, Stratford, CT (US)
- (\*\*) Term: **15 Years**

1,888,343 A	11/1932	Bohlman et al.
2,139,413 A	10/1933	Kreidel
2,100,796 A	11/1937	Church
2,158,757 A *	5/1939	Kuestermeier ..... F16L 19/083 285/340
2,233,214 A	2/1941	Neil
2,255,673 A	9/1941	McDermott
2,448,888 A	9/1948	Hynes
2,474,319 A	6/1949	Jacques
2,503,169 A	4/1950	Phillips
2,651,529 A	7/1951	Wayman

(Continued)

(21) Appl. No.: **29/559,036**

(22) Filed: **Mar. 24, 2016**

**Related U.S. Application Data**

- (63) Continuation-in-part of application No. 14/068,663, filed on Oct. 31, 2013, now Pat. No. 9,343,883.
- (51) **LOC (10) Cl.** ..... **23-01**
- (52) **U.S. Cl.**
- USPC ..... **D23/259**
- (58) **Field of Classification Search**
- USPC ..... D23/262-266, 269; D13/149-151; D8/382, 387, 396-397, 399; 285/154.1, 285/151.1, 149.1, 248-249, 340-343, 354
- CPC . F16J 15/10; F16J 15/028; F16L 19/06; F16L 19/08; F16L 19/061; F16L 5/06; H02G 3/0616; H02G 3/065; H02G 3/0658
- See application file for complete search history.

(56) **References Cited**

**U.S. PATENT DOCUMENTS**

1,186,812 A	6/1916	McFerran
1,327,106 A	1/1920	Leahy
1,488,175 A	3/1924	Strandell
1,772,536 A	8/1930	Cox
1,796,806 A	3/1931	Pearson
1,809,582 A *	6/1931	Church ..... F16L 19/08 285/154.1
1,809,583 A	6/1931	Church

**FOREIGN PATENT DOCUMENTS**

CN 102011904 A 4/2011

*Primary Examiner* — Eric Goodman

*Assistant Examiner* — Amy Wierenga

(74) *Attorney, Agent, or Firm* — Ware, Fressola, Maguire & Barber LLP

(57) **CLAIM**

The ornamental design for a raintight fitting connector body, as shown and described.

**DESCRIPTION**

FIG. 1 is a front perspective view of the raintight fitting connector body of my design;  
 FIG. 2 is a right side view thereof;  
 FIG. 3 is left side view thereof;  
 FIG. 4 is top view thereof;  
 FIG. 5 is a bottom view thereof;  
 FIG. 6 is a front view thereof;  
 FIG. 7 is a rear view thereof; and,  
 FIG. 8 is an elevational view of FIG. 2 shown in a position of use.

The dashed lines shown in FIG. 7 depict portions of the article that form no part of the claim. The dashed lines shown in FIG. 8 depict environmental subject matter that forms no part of the claim.

**1 Claim, 4 Drawing Sheets**

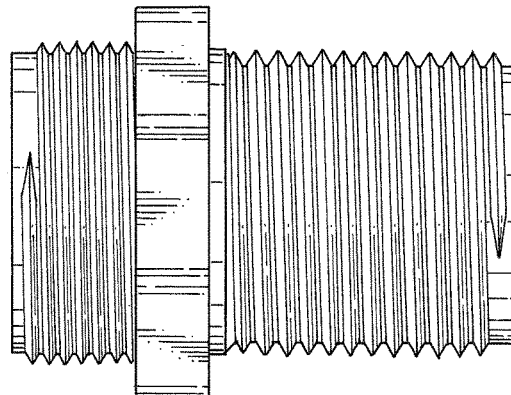
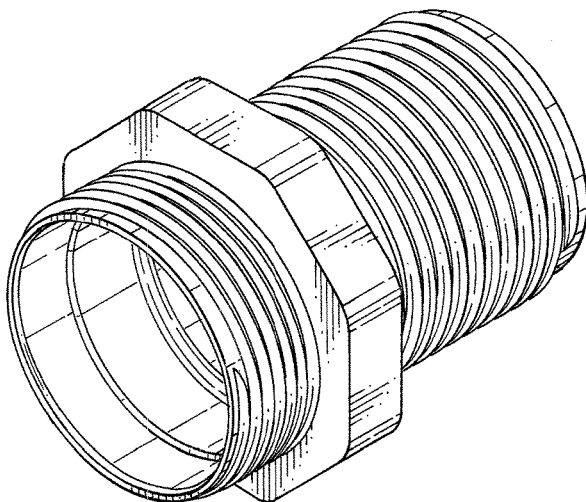

# US D787,648 S

Page 2

(56)

## References Cited

### U.S. PATENT DOCUMENTS

2,761,705	A	9/1956 Kreidel	6,641,180	B2	11/2003 Udhoefner
2,833,569	A	5/1958 Budnick	6,702,336	B1	3/2004 Chelchowski et al.
2,836,438	A	5/1959 Turnipseed	6,835,088	B2	12/2004 Shemtov
3,275,347	A	9/1966 William	6,840,550	B2	1/2005 Sundholm
3,393,931	A	7/1968 Wurzbarger	6,851,728	B2	2/2005 Minami
3,647,934	A	3/1972 Hurtt	6,988,746	B2	1/2006 Olson
3,667,783	A	6/1972 Sotolongo	7,002,077	B2	2/2006 Pyron
3,794,362	A	2/1974 Mooney	7,080,859	B1	7/2006 Gretz et al.
3,801,131	A	4/1974 Appleton	7,390,027	B2 *	6/2008 Kiely ..... F16L 19/061
3,891,294	A *	6/1975 Philibert ..... H02G 3/0683			174/652
		174/663			
3,907,335	A	9/1975 Burge et al.	7,438,327	B2	10/2008 Auray
3,972,547	A	8/1976 Itoya	7,604,261	B2 *	10/2009 Kiely ..... F16L 19/061
4,019,762	A	4/1977 Eidelberg et al.			285/248
4,030,741	A	6/1977 Fidrych	7,841,630	B1	11/2010 Auray
4,145,075	A	3/1979 Holzmann	7,900,974	B1 *	3/2011 Plattner ..... F16L 19/061
4,250,348	A	2/1981 Kitagawa			285/332.1
4,376,873	A	3/1983 Lackinger	7,976,070	B2 *	7/2011 Kiely ..... F16L 19/061
4,508,466	A	4/1985 Dennis			174/652
4,515,991	A	5/1985 Hutchison	8,129,633	B1	3/2012 Shemtov
4,547,623	A	10/1985 Van Brunt et al.	8,474,877	B2	7/2013 Smith
4,549,755	A	10/1985 Kot et al.	D691,033	S *	10/2013 Allman ..... D8/397
4,606,562	A	8/1986 Saraceno	D709,834	S *	7/2014 Liu ..... D13/151
4,608,454	A	8/1986 Lackinger	D712,840	S *	9/2014 Sykes ..... D13/151
4,676,533	A	6/1987 Gerondale	9,343,883	B2 *	5/2016 DeCesare ..... H02G 3/0616
4,877,270	A	10/1989 Phillips	2004/0090067	A1	5/2004 Pridham
4,915,427	A	4/1990 Zahuranec	2005/0035593	A1 *	2/2005 Auray ..... F16L 19/063
4,983,784	A	1/1991 Whitlock			285/154.1
5,028,078	A	7/1991 Schwarz et al.	2005/0194785	A1	9/2005 Shemtov
5,037,140	A	8/1991 Anderson	2005/0212288	A1 *	9/2005 Stewart ..... F16L 19/065
5,068,494	A	11/1991 Bolante			285/249
5,208,427	A	5/1993 Couto et al.	2007/0205601	A1 *	9/2007 Shemtov ..... F16L 5/06
5,230,536	A	7/1993 Rider et al.			285/151.1
5,393,109	A	2/1995 Gumpel	2008/0143103	A1	6/2008 Kiely
D363,767	S *	10/1995 Swaim ..... D23/260	2014/0117660	A1 *	5/2014 Smith ..... H02G 3/088
5,466,890	A	11/1995 Stagnitti			285/141.1
5,621,191	A	4/1997 Norris et al.	2014/0265321	A1 *	9/2014 DeCesare ..... H02G 3/0616
5,951,327	A	9/1999 Marik			285/343
6,073,976	A	6/2000 Schmidt et al.	2015/0048614	A1 *	2/2015 Coyle, Jr. .... F16L 19/12
6,268,565	B1	7/2001 Daoud			285/322
D462,058	S *	8/2002 Montena ..... D13/133	2015/0069750	A1 *	3/2015 Jung ..... H02G 3/0412
D469,742	S *	2/2003 Michon ..... D13/151			285/14
			2016/0204587	A1 *	7/2016 DeCesare ..... F16J 15/028
					285/343

\* cited by examiner

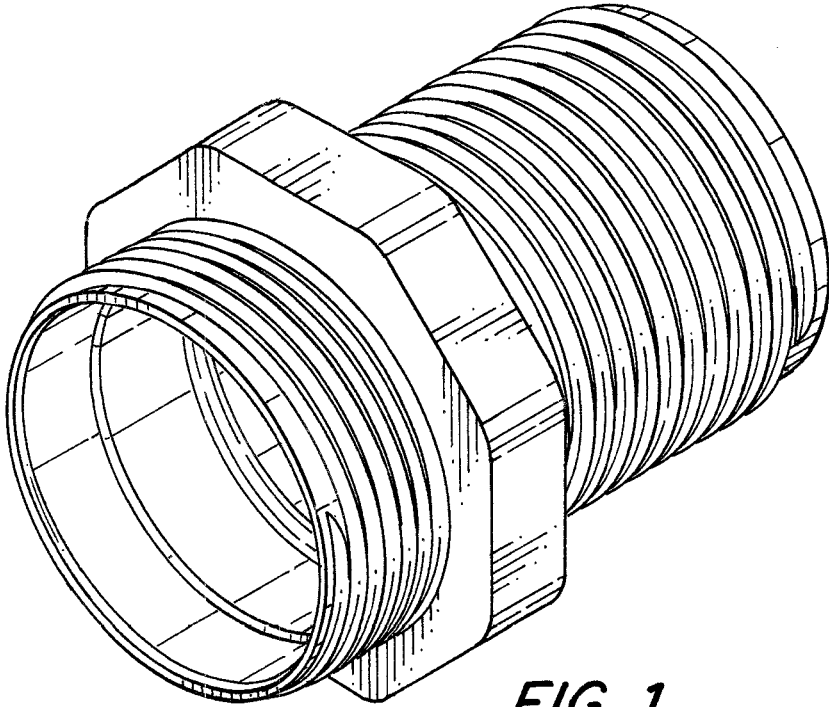

*FIG. 1*

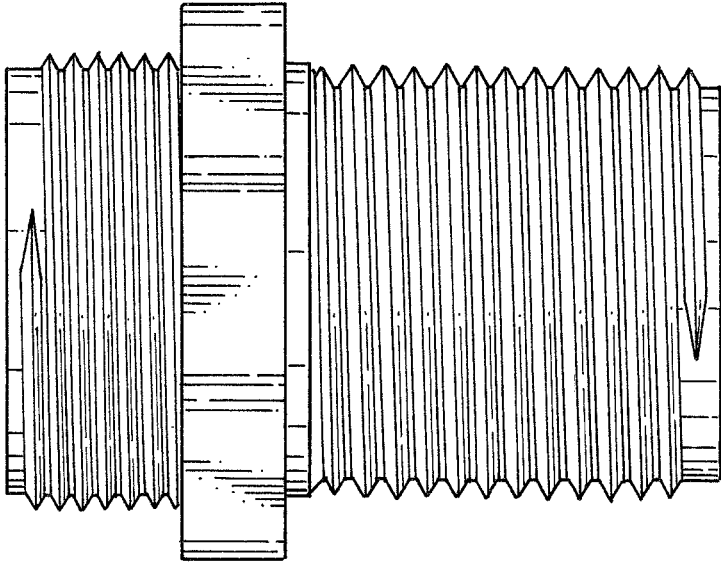

*FIG. 2*

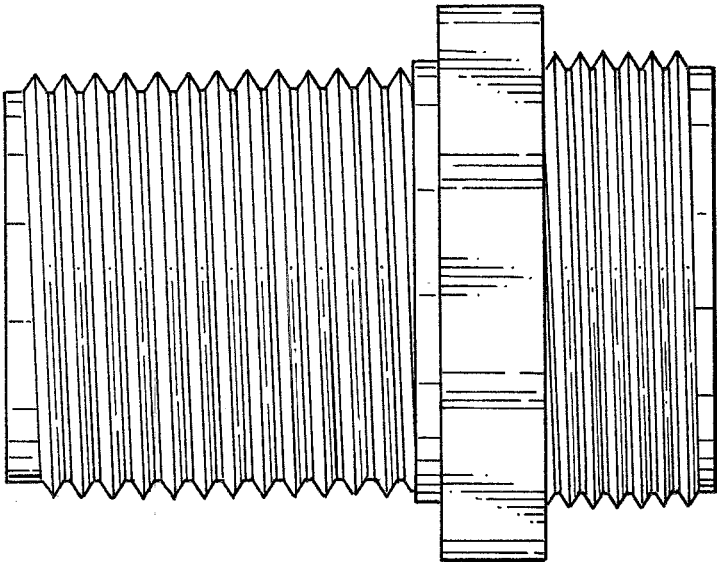

*FIG. 3*

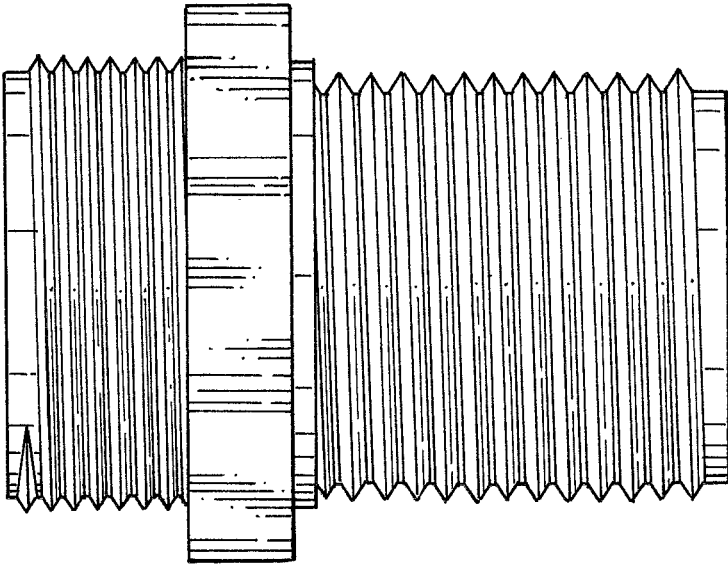

*FIG. 4*

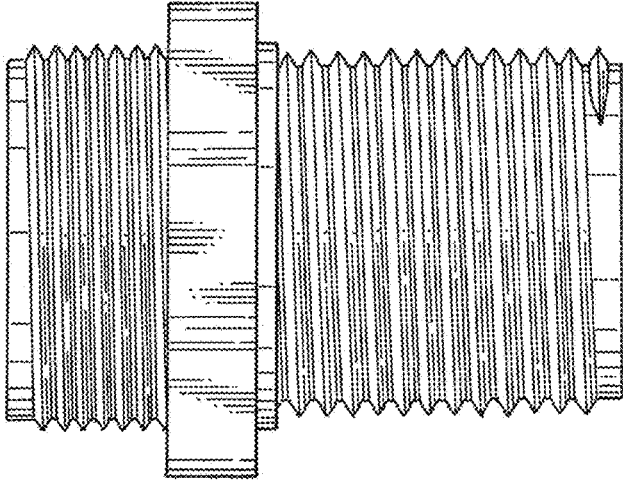

FIG. 5

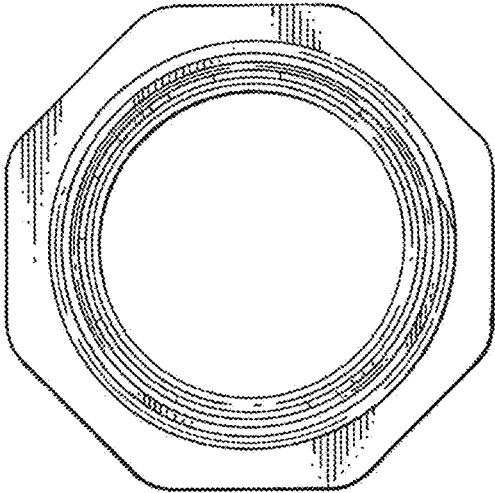

FIG. 6

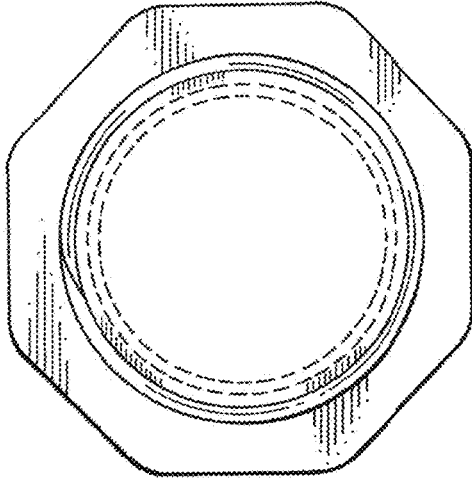

FIG. 7

