

(12) PATENT
(19) AUSTRALIAN PATENT OFFICE

(11) Application No. AU 199857907 B2
(10) Patent No. 735726

(54) Title
Integrated multipane window unit and sash

(51)⁶ International Patent Classification(s)
E06B 003/66

(21) Application No: 199857907

(22) Application Date: 1997 .11 .24

(87) WIPO No: W098/25001

(30) Priority Data

(31) Number	(32) Date	(33) Country
60/032776	1996 .12 .05	US
08/935924	1997 .09 .23	US

(43) Publication Date : 1998 .06 .29

(43) Publication Journal Date : 1998 .08 .20

(44) Accepted Journal Date : 2001 .07 .12

(71) Applicant(s)
John S. France

(72) Inventor(s)
John S. France

(74) Agent/Attorney
JOHN CHRISTIANSEN,PO Box 287,PORT MELBOURNE Vic 3207

(56) Related Art
US 4753056
US 4904732
US 5364921

OPI DATE 29/06/98 APPLN. ID 57907/98
ACJP DATE 20/08/98 PCT NUMBER PCT/US97/21752



AU9857907

(T)

(51) International Patent Classification ⁶ : E06B 3/66		A2	(11) International Publication Number: WO 98/25001
(21) International Application Number: PCT/US97/21752		(43) International Publication Date: 11 June 1998 (11.06.98)	
(22) International Filing Date: 24 November 1997 (24.11.97)		(81) Designated States: AL, AM, AT, AU, AZ, BA, BB, BG, BR, BY, CA, CH, CN, CU, CZ, DE, DK, EE, ES, FI, GB, GE, GH, HU, ID, IL, IS, JP, KE, KG, KP, KR, KZ, LC, LK, LR, LS, LT, LU, LV, MD, MG, MK, MN, MW, MX, NO, NZ, PL, PT, RO, RU, SD, SE, SG, SI, SK, SL, TJ, TM, TR, TT, UA, UG, UZ, VN, YU, ZW, ARIPO patent (GH, KE, LS, MW, SD, SZ, UG, ZW), Eurasian patent (AM, AZ, BY, KG, KZ, MD, RU, TJ, TM), European patent (AT, BE, CH, DE, DK, ES, FI, FR, GB, GR, IE, IT, LU, MC, NL, PT, SE), OAPI patent (BF, BJ, CF, CG, CI, CM, GA, GN, ML, MR, NE, SN, TD, TG).	
(30) Priority Data: 60/032,776 5 December 1996 (05.12.96) US 08/935,924 23 September 1997 (23.09.97) US		Published <i>Without international search report and to be republished upon receipt of that report.</i>	
(71)(72) Applicant and Inventor: FRANCE, John, S. [US/US]; 633 Ridgeline Drive, Cuyahoga Falls, OH 44223 (US).			
(74) Agent: BOLEY, William, F.; Dow Corning Corporation, Patent Dept. - C01232, P.O. Box 994, Midland, MI 48686-0994 (US).			

(54) Title: INTEGRATED MULTIPANE WINDOW UNIT AND SASH

(57) Abstract

A window unit comprising a sash and two or more essentially parallel spaced apart glazing panes where the sash comprises an integral spacing structure for maintaining the glazing panes in the essentially parallel spaced apart configuration.

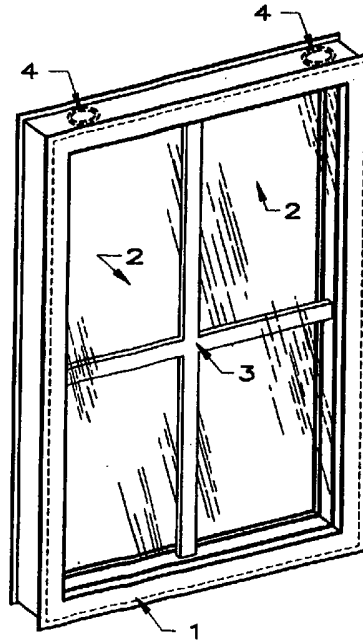

INTEGRATED MULTIPANE WINDOW UNIT AND SASH

BACKGROUND OF INVENTION

5 A window unit comprising a sash and two or more essentially parallel spaced apart glazing panes where the sash comprises an integral spacing structure for maintaining the glazing panes in the essentially parallel spaced apart configuration.

10 Insulating glass units (IG units) are used in windows and doors to reduce heat loss from building interiors in winter and into air-conditioned building interiors in summer. The insulating glass units are typically formed separate from the sash and then in a separate step the insulated glass unit is installed in a sash. In the present invention the IG unit and sash are fabricated as a single unit, thereby eliminating the need for a separate manufacture of the IG unit.

15 IG units generally consist of two or more parallel sheets of glass which are spaced apart from each other and which have the space between the panes sealed along the peripheries of the panes to enclose an air space between them. Spacer bars are placed along the periphery of the space between the two panes. The spacer bars are typically long hollow perforated metal sections, usually made from an aluminum alloy and fabricated either in the form of an extrusion or by rolling from flat strip material. The hollow interior of the spacer contains a desiccant material which is used
20 to absorb any residual moisture that may be in the enclosed air and absorb any additional moisture that may enter into the sealed unit over a period of time. The spacers are assembled into a generally rectangular-shaped frame either by bending or the use of corner keys.

25 IG units are constructed using either a single or dual seal. For single seal units, the structural, air and moisture vapor seal is combined in one seal. Sealant materials typically used with single seal design include either thermoplastic sealants such as butyl or thermosetting sealants such as polysulphide and polyurethane. In general, the thermosetting sealants are more permeable to moisture vapor than the
30 thermoplastic sealants.

For dual seal IG units, there is an inner seal, as well as the main outer seal with the inner seal generally functioning as an additional moisture vapor seal. Typically, for dual seal units, the inner seal is a thermoplastic material such as polyisobutylene and a bead of the polyisobutylene is attached to the sides of the
5 spacer adjacent to the glass sheets. The spacer frame is then placed between the panes and heat and/or pressure is applied to ensure that the polyisobutylene is compressed and fully wets out on the surface of the glass. For the second outer seal, typically a thermosetting sealant such as silicone, polyurethane, or polysulphide is used and is applied in the outward facing perimeter between the
10 two glass panes.

The construction of IG units, as described above, are well known in the art and are described in, for example, Bowser et al., U.S. Pat. No. 3,919,023; Reichert et al., U.S. Pat. No. 4,994,309; Dawson, U.S. Pat. No. 4,479,988; Leopold, U.S. Pat. No. 5,313,761; and Peterson U.S. Pat. No. 5,568,714. Manufacturing
15 methods for such IG units are also well known and are described, for example, in Leopold, U.S. Pat. No. 5,295,292. The IG units as described above are constructed as a separate and distinct unit which is then incorporated into a sash. The sash having incorporated therein the IG units can then be installed as a window, door, or insulating panel in buildings, refrigerated units, vehicles, and
20 the like.

The invention provides a window unit comprising a sash and two or more substantially parallel spaced apart glazing panes, where the sash comprises an integral spacing structure for maintaining the glazing panes in the substantially parallel spaced apart configuration, and the glazing panes are adhesively affixed
25 to the spacing structure by respective strips of adhesive that run along said spacing structure without extending over the edges of said glazing panes.

The invention also provides a window unit comprising a sash and two substantially parallel spaced apart glass panes, where the sash comprises an integral spacing structure for maintaining the glass panes in the substantially parallel spaced apart configuration, the sash and integral spacing structure being



2a

formed from a plastic comprising polyvinylchloride as a major component, and the glazing panes are adhesively affixed to the spacing structure by respective strips of adhesive that run along said spacing structure without extending over
5 the edges of said glazing panes.

It can be seen that the present inventor has invented and describes herein a window unit comprising an integrated window sash design where the window sash incorporates an integral spacing structure to allow two or more glazing panes to be glazed directly to the sash member in substantially parallel spaced
10 apart configuration. The integrated window sash design allows for the manufacture of a window unit comprising a sash and insulating panes as a single unit, thereby eliminating the cost and processing steps associated with making a separate IG unit and then installing the IG unit in a sash.

Throughout this specification, the terms "aluminum" and "aluminium" are used
15 interchangeably, and the terms "fiberglass" and "fibreglass" are also used interchangeably.

5
10
15



BRIEF DESCRIPTION OF DRAWINGS

Figure 1 illustrates a window unit comprising a sash having two essentially parallel spaced apart glazing panes contained therein.

Figure 2 illustrates a cross-section of a sash comprising two parallel spaced apart glazing panes maintained in an essentially parallel spaced apart configuration by an integral spacing structure of the sash.

Figure 3 illustrates a cross-section of a sash comprising an integral spacing structure.

DESCRIPTION OF INVENTION

The present invention is a window unit comprising a sash and two or more essentially parallel spaced apart glazing panes where the sash comprises an integral spacing structure for maintaining the glazing panes in the essentially parallel spaced apart configuration.

The present invention will now be explained by reference to Figures 1-3 provided herein. Figure 1 illustrates a window unit within the scope of the present invention. The window unit represented by Figure 1 comprises sash 1 having positioned therein two essentially parallel spaced apart glazing panes 2. Also illustrated in Figure 1 is muntin bar simulating assembly 3 positioned between glazing panes 2 and attached to sash 1. Sash 1 contains sealed channels 4 for evacuating the space between glazing panes 2 and if desired providing an insulating gas between glazing panes 2.

Those skilled in the art will appreciate that the present invention is not limited to a window unit as represented in Figure 1, but can include window units suitable for use as casement windows, double hung windows, single hung windows, permanent and fixed position windows, and insulating panels for both residential and commercial buildings. The window unit comprising the present invention may be used as doors and windows, for example, in refrigerators and refrigerated display cases. The window unit comprising the present invention may be used as windows in vehicles including automobiles, trucks, heavy construction equipment, and boats.

The sash of the present invention can be constructed of standard materials for constructing window unit sashes. By the term "sash" it is meant a component

adapted to enclose the periphery of the two or more glazing panes thereby forming a window unit suitable for positioning and affixing to a support structure such as, for example, a window frame, building structure, refrigerated unit, or vehicle. The material of construction of the sash can be, for example, wood, metal such as aluminum, plastic, such as ABS or styrene, fiberglass, plastic composites, and composites comprising wood and plastic. Considerations in choosing the material of construction of the sash include compressive strength, hardness, brittleness, coefficient of elasticity, thermal conductivity, workability, ability to retain fasteners, and appearance, and cost. The method of fabricating the sash is not critical to the present invention and will dependent upon the material of fabrication. The sash may be fabricated by such methods as milling, rolling, stamping, extruding, molding, and combinations thereof.

A preferred sash for use in the present invention is constructed from a plastic comprising polyvinylchloride (PVC) as a major component. The PVC may contain minor amounts of additives such as process aids, process modifiers, solid fillers, reinforcing materials, lubricants to facilitate extrusion, and curing compounds. In addition the PVC may contain other polymeric components as blends or mixtures to modify the performance of the PVC. In a preferred embodiment of the present invention the sash is formed by extrusion of PVC.

The sash is adapted to enclose the periphery of two or more glazing panes. As illustrated in Figure 1, in one embodiment the sash is formed in a rectangular or square format. However, the shape of the sash is not critical to the present invention as long as the sash adequately conforms to the shape of the glazing panes. The sash may be formed, for example, as multiple components which are then joined at mitered ends by such methods as screws, rivets, bolts, clips, inserts, and welding or combinations thereof. The sash may be formed as a single linear component by such means as stamping or extruding and then the linear component bent to an appropriate configuration and joined end-to-end by such methods as previously described.

The sash of the present window unit comprises an integral spacing structure for maintaining two or more glazing panes in an essentially parallel spaced apart configuration. By the term "integral" it is meant that the spacing structure is part of

the sash and that the glazing panes are affixed separately to the spacing structure as part of the sash. By way of illustration, Figure 2 represents a cross-section of sash 1 having integral spacing structure 5. Figure 2 illustrates an example of a sash within the scope of the present invention comprising integral spacing structure 5. Figure 2 is not intended to limit the scope of the claims herein to such structures. The physical shape of the integral spacing structure is not critical to the present invention as long as it can maintain the two or more glazing panes in an essentially parallel spaced apart configuration. The physical shape will depend to an extent on the material of composition of the sash. Although it is preferred that the integral spacing structure be prepared as part of the process of, for example, milling, extruding, or stamping the sash, the integral spacing structure can be made separately and then attached to the sash by such methods as gluing, welding, bolts, screws, and similar such attachment methods. The sash and integral spacing structure can be made of similar or different materials. For example, the sash may be formed as a co-extrusion where the sash and the integral spacing structure are made from different polymeric materials. In some applications, for example, a co-extrusion method may be desirable to provide a sash with adequate physical properties such as strength and an integral spacing structure with, for example, an acceptable coefficient of expansion and adhesion properties to be compatible with the glazing panes. The integral spacing structure can be in the form of, for example, a solid ridge, hollow ridge, or trough. The shape of the integral spacing structure is not important as long as sufficient surface area and strength is provided for the two or more glazing panes to be maintained in essentially parallel spaced apart configuration by, preferably, an adhesive interposed between the walls of the integral spacing structure and the inside surface edge of the glazing panes. Figure 2 illustrates a preferred configuration for the integral spacing structure, where the structure forms a trough into which a desiccant may be placed and into which a muntin simulating assembly maybe secured by, for example, clips or friction fit.

The window unit of the present invention comprises two or more essentially parallel spaced apart glazing panes. By the term "essentially parallel" it is meant that the glazing panes when positioned in the sash abutting the integral spacing structure and any intervening materials such as adhesive and barrier materials form an inner

chamber. The glazing panes can be sheets formed from, for example, simple glass, tempered glass, safety glass, glass-thermoplastic laminates, or thermoplastics. The glazing panes may be clear or translucent. The glazing panes may be coated with standard coatings for reducing ultraviolet and visible light transmission. The glazing panes be colored by those methods known in the art. The preferred glazing panes for use in the present window unit comprise glass and glass laminates.

Although the sash structure illustrated in Figures 1-3 provides for the positioning of two glazing panes, the present invention is not limited to only two glazing panes. The present sash may be designed to accommodate additional glazing panes or films positioned between the essentially parallel glazing panes.

The present invention is further illustrated by reference to Figure 3. Figure 3 illustrates a cross-sectional area of a window unit within the scope of the present invention. In Figure 3, sash 1 comprises integral spacing structure 5. Glazing panes 2 are positioned within the sash structure with their edges adjacent to integral spacing structure 5 and maintained thereby by adhesive 6. Positioned within the cavity formed between glazing panes 2 is muntin simulating assembly 3, which is maintained in position by means of a clip inserted into a slot extending the long axis of the integral spacing structure. Positioned within integral spacing structure 5 is adsorbent 7. Sash 1 further comprises grooves 8 into which glazing beads 9 can be positioned and secured thereby forming a weather seal adjacent the outer surfaces of panes 2.

In a preferred embodiment of the present window unit the two or more essentially spaced apart glazing panes are attached to the integral spacing structure by an adhesive such as a structural sealant. It is further preferred that the adhesive be capable of forming an air and moisture resistant seal between the integral spacing structure and the glazing panes. The specific adhesive required will depend upon the materials of construction of the sash and the glazing panes as well as the conditions of use of the window unit. A wide variety of materials may be considered for use as the adhesive. For example, the adhesive may be a natural or synthetic thermoplastic resin such as polysulphide, polyurethane, polyisobutylene, epoxy, epoxy polysulphide mixture, and polysulphide-polyurethane mixture. The adhesive may be a heat curable platinum catalyzed silicone rubber composition as described in Gray, et al., U. S. Pat.

No. 5,364,921 which is hereby incorporated by reference as teaching adhesive compositions which may be useful in the present invention. The adhesive may be a room temperature curable composition comprising an acrylic-functional isobutylene polymer as described by Saxena et al., U. S. Pat. No. 5,665,823, which is hereby
5 incorporated by reference as teaching examples of adhesive compositions which may be useful in the present invention. Preferred is when the adhesive is a room temperature curable composition such as described in Saxena et al., supra. The adhesive may be a preformed glazing tape comprising materials such as butyl, polyethylene, polyurethane, or polyvinylchloride.

10 In a preferred embodiment of the present invention an adsorbent or absorbent is positioned within the space created between the glazing panes to prevent moisture accumulation between the panes and if necessary to adsorb chemical species which may be emitted into the space between the glazing panes and cause fogging of the glazing panes. For purposes herein the terms adsorbent and absorbent are collectively
15 referred to as adsorbent to indicate those materials which by either adsorption or absorption are able to retain water, chemical species, or both. In a preferred embodiment, adsorbent 7 is positioned within a channel formed by the integral spacing structure. Those skilled in the art will recognize that the channel formed by the integral spacing structure may have various configurations such as rectangular,
20 square, and oval and need not be entirely open to the space created between the glazing panes. The channel formed by or within the integral spacing structure may communicate with the space created between the glazing panes, for example by means of a slot as illustrated in Figure 3 or by holes spaced along the integral spacing structure connecting a channel formed within the integral spacing structure with the
25 space created between the glazing panes.

The adsorbent or adsorbents which may be used in the present window unit may be any of the naturally occurring or synthetically produced adsorbents which will adsorb water and preferably any chemical species released into the space formed by the glazing panes which may cause fogging of the panes. Preferred adsorbents are
30 zeolite A, zeolite X, and mixtures thereof. The physical form of the adsorbent used will depend upon the channel formed within the integral spacing structure. The

adsorbent may be in the form of a powder, in which case the channel formed within the integral spacing structure must be essentially closed with suitably sized holes connecting the channel with the space created between the glazing panes. For example, Ulsich, U. S. Pat. No. 3,868,299 discloses the use of an adsorbent designed for use in multiple layer insulating glass windows comprising a narrow-pore zeolite in combination with a wide-pore adsorbent, and optionally a clay binder. The teachings of Ulsich, supra, are hereby incorporated by reference as teaching examples of desiccants useful in the present invention. Cohen et al., U. S. Pat. No. 5,493,821 teaches hollow, low-density agglomerates useful for adsorbing water which may be useful in the present invention, and these teachings are hereby incorporated by reference for teaching such useful adsorbents.

The adsorbent may be in a matrix in which a particulate adsorbent is incorporated in a vehicle material which is adhered within the channel formed in the integral spacing structure. The vehicle material may be, for example, silicone rubber, butyl, hot melt, or polyurethane. The adsorbent may be incorporated into a curable liquid silicone rubber composition or sealant which is extruded into a channel formed in the integral spacing structure and adheres thereto upon curing.

To improve the insulating performance of the window unit of the present invention it may be desirable to evacuate the air from the space created between the glazing panes or to replace the air with an inert gas such as nitrogen, argon, or krypton. As illustrated in Figure 1, sealed channels 4 may be provided in the sash for effecting the formation of a vacuum or replacement of air with a gas.

In Figure 3, sash 1 comprises grooves 8 into which glazing beads 9 can be positioned and secured thereby forming a weather seal adjacent the outer surfaces of panes 2. The shape of grooves 8 are not critical to the present invention and the shape illustrated in Figure 3 is only one of many possible. It is preferred that grooves 8 be of a shape such that glazing beads 9 can be snapped into place and retained. Alternatively glazing beads 9 could be press fitted into grooves 8 or glued to effect retention.

Glazing beads 9 are affixed to sash 1 and abutted to the outer surface of glazing panes 2. The material of construction of glazing beads 9 is not critical and can

be any of those materials known in the art for use in such applications. Glazing beads 9 can be fabricated from, for example, natural or synthetic rubber, or a plastic.

Glazing beads 9 can be fabricated from, for example, a silicone rubber. Glazing beads 9 can also serve an ornamental purpose and therefore may be fabricated by such methods as extrusion into ornamental shapes and designs and may be colored as required.

Also illustrated in Figures 1 and 3 is muntin bar simulating assembly 3 positioned between glazing panes 2 and affixed to sash 1 by means of a slot in integral spacing structure 5. Muntin bar simulating assembly 3 is optional to the present invention and can be of convention design and materials of fabrication as known in the art. It is preferred that muntin bar simulating assembly 3 be fabricated from aluminum or a plastic material that does not release chemical species into the space created between the glazing panes that could cause fogging of the glazing panes. Muntin bar simulating assembly 3 may be fabricated such that it readily clips onto the sash, one such design of which is illustrated in Figure 3.

THE CLAIMS DEFINING THE INVENTION ARE AS FOLLOWS:

1. A window unit comprising a sash and two or more substantially parallel spaced apart glazing panes, where the sash comprises an integral spacing structure for maintaining the glazing panes in the substantially parallel spaced
5 apart configuration, and the glazing panes are adhesively affixed to the spacing structure by respective strips of adhesive that run along said spacing structure without extending over the edges of said glazing panes.
2. A window unit according to claim 1, where the sash and the integral spacing structure are formed from aluminium.
- 10 3. A window unit according to claim 1, where the sash and the integral spacing structure are formed from polyvinylchloride.
4. A window unit according to any preceding claim, where the glazing panes are independently selected from the group consisting of simple glass pane, tempered glass pane, safety glass pane, glass-thermoplastic laminate pane, and
15 thermoplastic pane.
5. A window unit according to claim 1, where the glazing panes are glass panes.
6. A window unit according to claim 1, wherein the glazing panes are glass laminate panes.
- 20 7. A window unit according to any preceding claim, wherein the adhesive is a heat curable platinum catalyzed silicone rubber composition.
8. A window unit according to any one of claims 1 to 6, where the adhesive is an acrylic-functional isobutylene polymer.
9. A window unit according to any preceding claim, where an absorbent,



adsorbent, or mixture of absorbent and adsorbent is positioned within the space created between the substantially parallel spaced apart glazing panes.

10. A window unit according to claim 9, where the integral spacing structure forms a trough communicating with the space between the two or more
5 substantially parallel spaced apart glazing panes and the trough contains the absorbent, adsorbent, or mixture of absorbent and adsorbent.

11. A window unit according to any preceding claim, where the space between the substantially parallel spaced apart glazing panes is filled with an inert gas.

12. A window unit according to claim 11, where the inert gas is selected from
10 the group consisting of nitrogen, krypton, and argon.

13. A window unit according to any preceding claim further comprising a muntin bar simulating assembly positioned between the substantially parallel spaced apart glazing panes.

14. A window unit according to claim 13, where the muntin bar assembly is
15 affixed to the integral spacing structure.

15. A window unit comprising a sash and two substantially parallel spaced
apart glass panes, where the sash comprises an integral spacing structure for
maintaining the glass panes in the substantially parallel spaced apart
configuration, the sash and integral spacing structure being formed from a plastic
20 comprising polyvinylchloride as a major component, and the glazing panes are
adhesively affixed to the spacing structure by respective strips of adhesive that
run along said spacing structure without extending over the edges of said glazing
panes.

16. A window unit according to any preceding claim, where the sash and the
25 integral spacing structure are formed from a plastic.



17. A window unit according to any one of claims 1 to 16, where the sash and the integral spacing structure are formed from a material from the group consisting of fibreglass, plastic composites, and composites comprising wood and plastic.
- 5 18. A window unit substantially as herein described with reference to the accompanying drawings.

DATED this 23 April 2001

JOHN CHRISTIANSEN

Member, Fédération Internationale des Conseils en Propriété Industrielle
(International Federation of Intellectual Property Attorneys)

10

Patent Attorney for the Applicant:

JOHN S. FRANCE



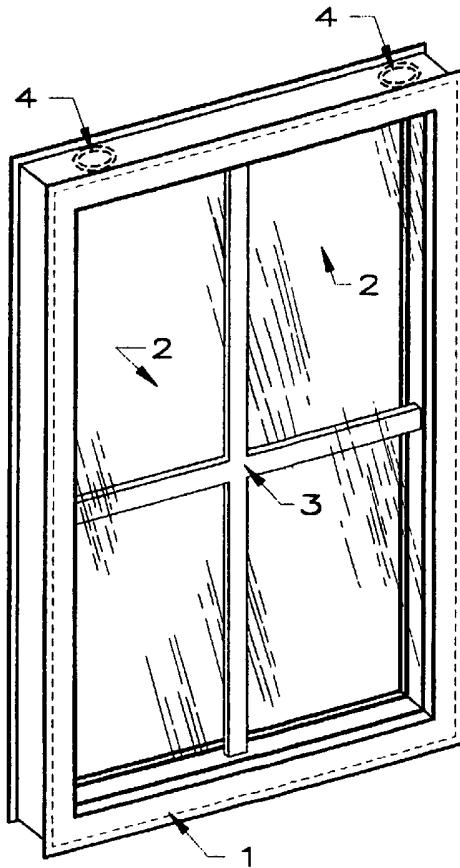

Fig. 1

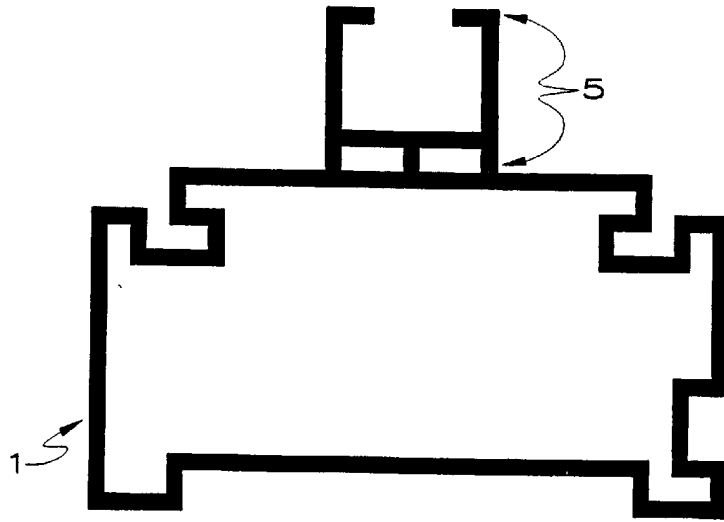

Fig. 2

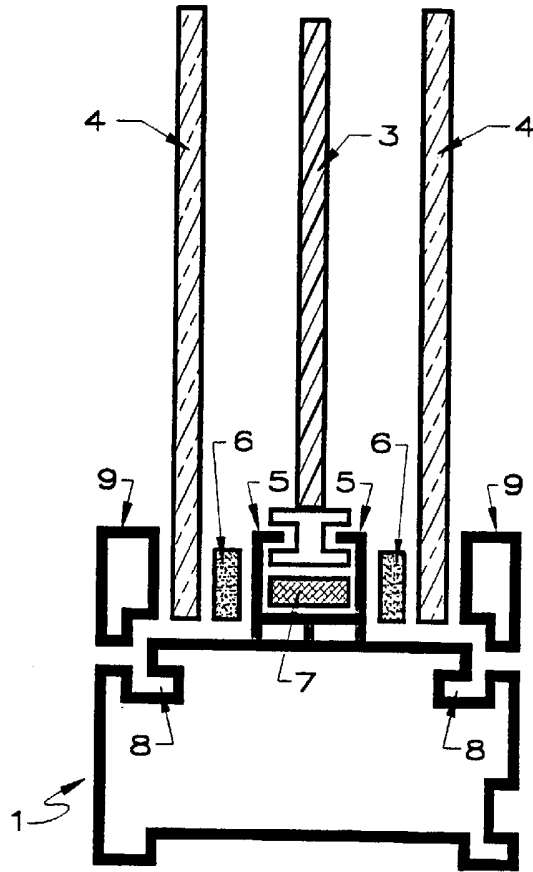

Fig. 3