

(No Model.)

2 Sheets—Sheet 1.

H. F. WHEELER. MAGAZINE PISTOL.

No. 546,369.

Patented Sept. 17, 1895.

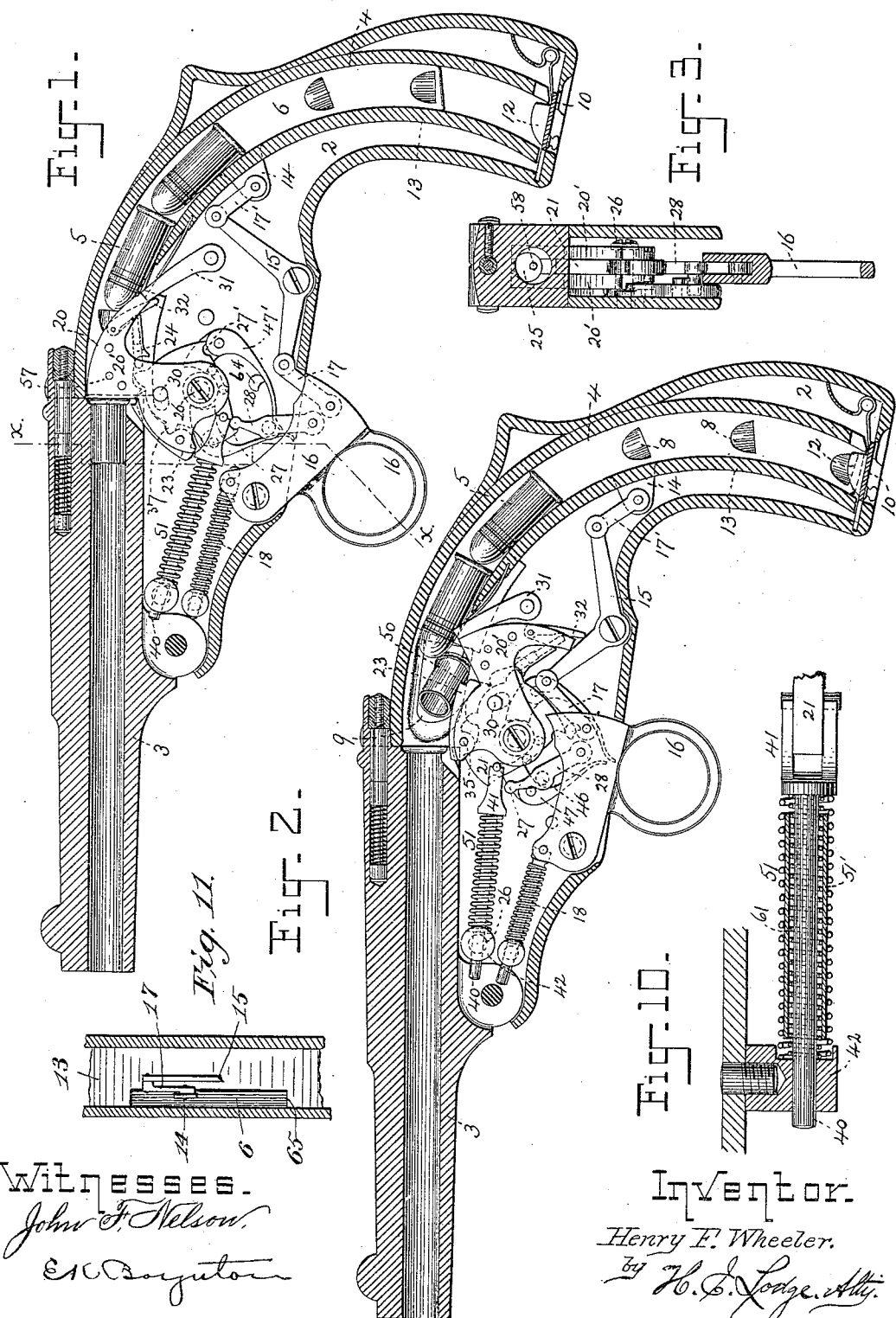

Witnesses.
John F. Nelson.
E. C. Boynton

Inventor.
Henry F. Wheeler.
 by *H. S. Lodge, Att'y.*

(No Model.)

2 Sheets—Sheet 2.

H. F. WHEELER.
MAGAZINE PISTOL.

No. 546,369.

Patented Sept. 17, 1895.

Fig. 4.

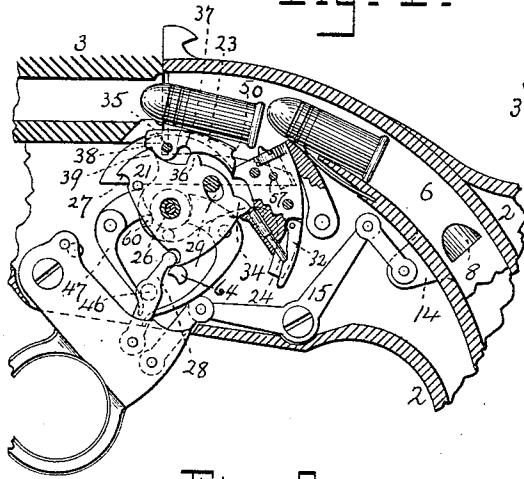

Fig. 5.

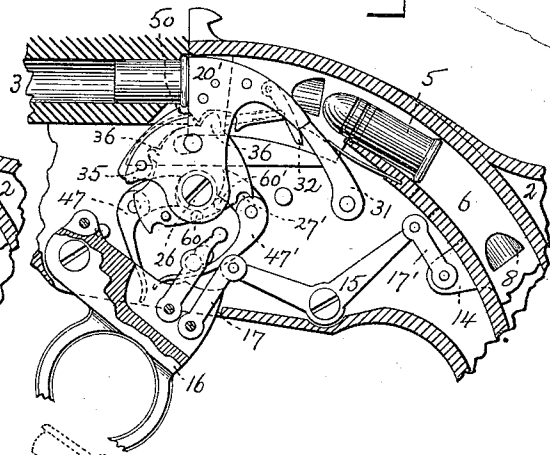

Fig. 8.

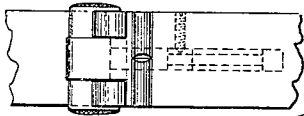

Fig. 6.

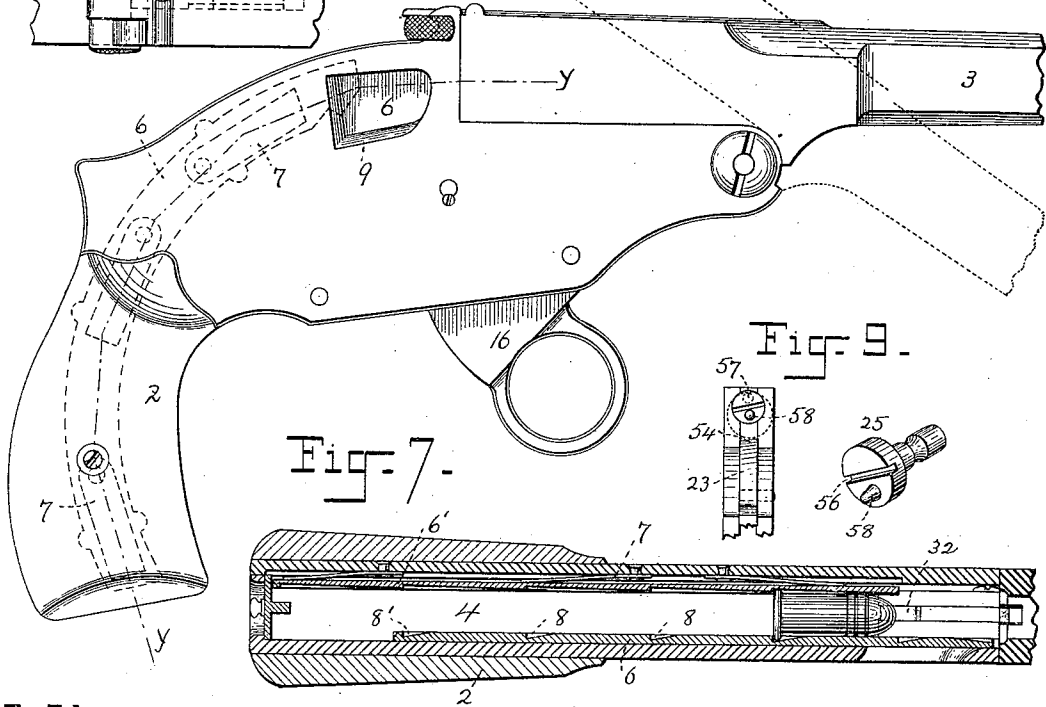
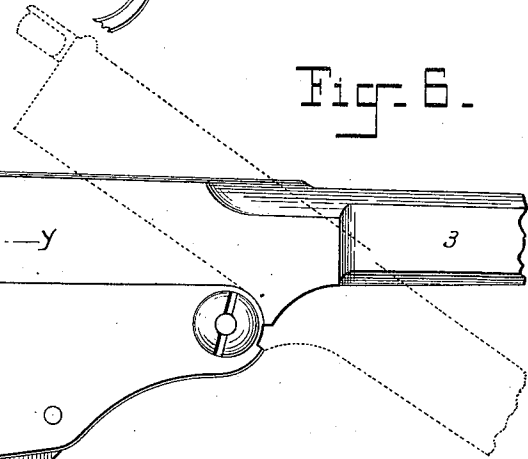
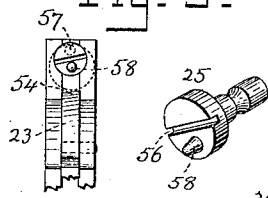

Fig. 9.



Witnesses.
John F. Nelson.
E. W. Dayton.

Inventor.
Henry F. Wheeler.
by H. C. Lodge Atty.

UNITED STATES PATENT OFFICE.

HENRY F. WHEELER, OF PETERBOROUGH, NEW HAMPSHIRE.

MAGAZINE-PISTOL.

SPECIFICATION forming part of Letters Patent No. 546,369, dated September 17, 1895.

Application filed October 24, 1894. Serial No. 526,842. (No model.)

To all whom it may concern:

Be it known that I, HENRY F. WHEELER, a citizen of the United States, residing at Peterborough, in the county of Hillsborough and State of New Hampshire, have invented certain new and useful Improvements in Magazine-Pistols; and I do hereby declare the following to be a full, clear, and exact description of the invention, such as will enable others skilled in the art to which it appertains to make and use the same, reference being had to the accompanying drawings, and to figures of reference marked thereon, which form a part of this specification.

This invention relates to firearms, particularly pistols; and its primary object is to produce a magazine weapon or one in which the cartridges are to be fed forward from the handle of the weapon to the barrel in contradistinction to that class in which a revoluble cylinder adapted to contain the several charges is caused to deliver them in succession opposite the breech of the barrel.

My invention is further embodied in the various instrumentalities by which the loaded cartridges are successively fed forward and entered in the breech or rear end of the barrel by the action of the trigger, and likewise in the extractor for ejecting the empty shells.

A prominent feature of my invention consists in a compound hammer fitted with a semirotary block or supplemental hammer, this latter part moving in advance of the main hammer, which latter it overtakes, and the two then move as one piece in the final act of cocking.

A further feature includes mechanism to create movement of the locking-bolt to release the hammer prior to cocking the weapon. Likewise in a magazine-feeder attached to the trigger and operated in one direction by the trigger-spring. Moreover, in an adjustable firing-pin adapted to be used either for rim or center-fire cartridges.

Other peculiar and novel characteristics will be more fully and specifically mentioned and described hereinafter.

The drawings represent, in Figure 1, a longitudinal section of the barrel, the parts in their relative positions after discharge of the weapon, and with the trigger in readiness to cock the hammer. Fig. 2 is a similar view of

a magazine-pistol embodying my invention, the several parts being shown in the act of discharging an empty shell and with the hammer cocked. Fig. 3 is a vertical transverse section on line *xx* in Fig. 1. Fig. 4 is a central longitudinal section in part showing the hammer cocked, while release of the trigger-spring has advanced the feeder-plate and partially inserted a cartridge within the barrel. Fig. 5 is a similar view just after the hammer has fallen. Fig. 6 is a side elevation showing the aperture for ejection of shells now closed. Fig. 7 is a section transversely of the magazine-chamber on line *yy* in Fig. 6. Fig. 8 is a plan of the locking mechanism to allow tilting of the barrel. Fig. 9 includes a face view of the firing-pin and the extractor in position, as likewise a perspective view of said pin enlarged. Fig. 10 is a sectional plan of the mainspring, enlarged. Fig. 11 is a sectional elevation showing the slot through which the feeder-plate is operated.

As before premised, this invention has for its object the elimination of the revoluble cylinder commonly in use in pistols for repetitive firing. In lieu thereof I propose to substitute a magazine in the stock or handle portion of the weapon; furthermore, to provide positive and direct feed of the cartridge, as likewise ready withdrawal and expulsion of the empty shells. In the present instance I have shown the weapon as composed of a stock 2 and a barrel 3, adapted to be tilted in order the more readily to cleanse the bore thereof. Within the stock is formed the magazine, comprising a curved passage-way 4 of a size to admit the loaded shells 5. These latter are arranged to be advanced along and fed successively forward at each movement of the trigger necessary to cock the hammer, and finally thrust into the rear end of the barrel, where they are held and discharged, as will be hereinafter explained.

The elements for properly advancing the several cartridges include two flat curved plates 6 6'. The latter plate is stationary, but is thrust laterally by springs 7 toward the opposite corresponding plate, which is adapted to reciprocate, and hence termed the "feed-plate." Furthermore, similar and corresponding notches 8 are cut in each plate to engage the rims of the shells, the length of

said plate being such that the rear end reaches the end of the stock to insure that the cartridge last inserted shall engage the feed-plate, while the front end of said feeder laps by and is intended to close an aperture 9 laterally in the stock, and through which empty shells are ejected. The feed-entrance to the magazine is closed by a sliding gate 10, fitted with an inwardly-projecting lug 12. This latter is intended to force the cartridge last entered home when closing the mouth of the magazine. Hence when the feed-plate is retracted in the act of cocking the weapon the rim of said cartridge will engage the lowest notch 8' in the feed-plate.

To actuate the feed-plate 6 I have formed a space 65 between the inner wall 13 of the magazine (see Fig. 11) and the adjacent side plate of the stock. Laterally of the feed-plate is affixed a lug 14, which projects beyond the magazine and moves in the above-mentioned space. A two-armed lever 15 is secured to the stock, the trigger 16 is likewise pivoted thereto, while links 17 17' interconnect the trigger, the lever, and the feeder-plate. As a result when the trigger is pulled to cock the hammer, this weapon being of the class termed "double-action," the feed-plate retreats and slides toward the end of the stock, at the same time opening the aperture 9 for the expulsion of an empty shell. In its retreat movement the feed-plate slides past the several cartridges, which are supported by the notches in the fixed plate 6, and thereby causes them to enter the next adjacent higher notch. When the trigger is released the spring 18, which serves to restore said trigger to its former position, likewise returns the feed-plate and closes the aperture 9 prior to the next discharge. Thus at each pull of the trigger every cartridge in the magazine is advanced one notch on the feed-plate, and comes nearer to the final point of delivery or the rear end of the barrel.

One of the peculiar features of my invention is embodied in the hammer, which comprises several elements all grouped and interconnected, but so positioned as to operate at different times. These several parts include a hammer-plate proper 20, which acts as a breech-block, a supplemental hammer 21, (see Fig. 4, in which drawing part of the main hammer is omitted,) an extractor 23, a bolt 24 to release the main hammer after a discharge, and a firing-pin 25. Specifically these various parts co-operate and are arranged as follows:

At 26 is the main pivot for the hammer, upon which are mounted twin plates 20', with the main hammer-plate 20 between them and which contains the firing-pin. Below the hammer-plate and likewise on the same pivot is a rocking plate 21, which is formed with two notches, one 27 for cocking, and one 27' for releasing the hammer. A fly 28, spring-actuated and carried by the trigger, successively engages said notches. In addition a

transverse slot 29 (see Fig. 4) is cut in the supplemental hammer 21, while a pin 30 extends therethrough and is fastened in the main hammer. Thus a limited travel of the supplemental hammer may occur before the main hammer moves. To effect this a swinging spring-actuated locking bolt or latch 31 is pivoted to the side plates of the stock and engages beneath the rear part of the main hammer, (see Figs. 1 and 5,) while a finger 32, secured on the main hammer, is intended to swing up and disengage this bolt or latch from said hammer. This disengagement of the latch or bolt and release of the hammer are produced through the agency of a push-pin 24 and an ear 34, projecting from the upper part of the supplemental hammer. (See Fig. 4.) Thus this initial movement of this portion 21 not only releases the main hammer preparatory to cocking, but it likewise actuates the extractor 23. This element consists of a curved bar located between the main-hammer plates 20' and in alignment with, but in front of, the supplemental hammer 21, and is held in place by a transverse pin 35. A tooth 36 on the hammer 21 enters a notch 37 in the extractor as a normal position, but upon rocking of the supplemental hammer said tooth leaves the notch and lifts the free end of the extractor during this initial hammer movement. A lip 38 on said extractor contacts with the point 39 (see Fig. 4) on the supplemental hammer, whereby engagement of the shell with the free end of the extractor is maintained, while the extractor is prevented from dropping, as it otherwise might, since the rocking of the hammer backward separates the tooth 36 from the extractor. This free end of the extractor is formed with a spur 50 of a form to fit and grasp the rim of the cartridge.

The hammer is spring-actuated; but in lieu of the spring I have provided double-coiled springs 51 51', secured about a rod 40, with an interposed sleeve 61 to prevent friction. This rod 40 terminates at one end in a stirrup 41, pivotally on the supplemental hammer, while the opposite end plays in a post 42, affixed to the frame. The passage of the pivot of this spring on either side of a straight line extended between the post 42 and the hammer-pivot 26 serves to allow the said spring to exert its tension either in holding the hammer down or in imparting momentum thereto when released in the act of firing. To maintain the fly 28 in one of two positions, either in the notch 27 or 27', as occasion may require, a lateral offset or pin 46 is inserted, and this part is adapted to engage alternately with the free ends of twin springs 47 47'. Thus in Figs. 4 and 5 this arrangement is illustrated. In Fig. 4 spring 47 is actively employed to hold the fly 28 in the notch 27' in position to release the hammer on a pull of the trigger, while after the weapon has been fired the opposite spring 47' is brought into use and thrusts the fly over into the cocking-

notch 27. Hence, in whichever position the hammer may be positive engagement of the fly with the cocking or firing notches is obtained. A spring 18, employed to operate the trigger, is constructed in a similar manner to that of the mainspring—that is, with a coiled spring or springs about a rod.

The activity or inactivity of the springs 47 47' is produced by means of two studs 60 60', which are mounted upon the main hammer and adapted to engage the rigid end portion of the springs. Thus in Fig. 4 the hammer is cocked, at which time the stud 60 bears firmly against the rigid end of the spring 47, while the free end of the latter is thrown inwardly against the fly and tends to thrust the latter into the firing-notch. Conversely, when the hammer is down after discharge of the weapon, as in Fig. 5, the corresponding stud 60' bears against the spring 47', which is rendered active in order to throw the fly into the cocking-notch.

It will be seen that the opening and closing of the breech requires two operations of the trigger mechanism, and that the connection between the trigger and the cartridge-carrying slide, being a positive one, would produce a double action of the said carrier unless provision was made to prevent such. This is effected as follows: As before premised, the fly, when in the cocking-notch, serves not only to cock the hammer and opens the breech, but produces a full retrograde motion of the carrier-slide in order that the notches in the latter may engage fresh cartridges and advance them before the breech is closed. After the hammer is cocked cessation of the pull allows the trigger to return to its normal forward position and advances the carrier-slide for an active feed movement. This act further allows the fly to enter and engage the firing-notch 27'. Now it is evident that the positive connection between the carrier-slide and trigger would create a second feed upon fall of the hammer and release of the trigger were such not prevented. This is effected by means of a stop 64, (see Figs. 1 and 4,) recessed upon its lower front portion, and which is designed to receive the pin 46 on the fly, and thus limit the movement of the trigger in this direction. This stop is so located with reference to the fly that the latter is permitted to advance sufficiently to release the hammer, but is then immediately stopped. Hence only a partial retreat movement of the carrier-slide is produced, and because said motion is so small no engagement of fresh cartridges takes place, and no second feed can occur. As soon as the pull on the trigger ceases and the latter resumes its normal position the carrier-slide likewise returns. This travel does not exceed a quarter of an inch. Conversely, in cocking the hammer the fly is in the other extreme of position, and for this reason the trigger is permitted full movement, since the stop cannot engage the fly, and hence remains an inactive element.

The operation of this firearm, comprising the above-described co-operating instrumentalities, is as follows: With the parts in the relative positions, as shown in Fig. 1, the gate 10 is opened and the magazine is filled, the cartridge first introduced assuming the position as there shown with respect to the hammer. Furthermore, it will be seen that a discharge has just occurred, an empty shell now resting in the breech of the barrel, while the fly 28 is in engagement with the cocking-notch 27. If the weapon is to be fired again, the trigger is pulled back. This lifts the fly and rocks the supplemental hammer, which, as it swings, causes the ear 34 to strike the push-pin 24 and forces the latter to advance against the holding bolt or latch 31. This bolt is thereby disengaged from the main hammer, which is now unlocked or cleared. A further result accomplished by this motion of the supplemental hammer is activity of the extractor. As will be seen in Fig. 1, the fall of the hammer has thrust the tooth 36 into the notch in said extractor; but as the supplemental hammer rocks the tooth moves out from the notch and the free end of the extractor is raised. This free end now rests with the spur 50 against the rim of the empty cartridge. A third duty performed by the supplemental hammer is as follows: Simultaneously with the movement of said hammer, the uplifting of the extractor, and the disengagement of the latch from the main hammer a change in the lever 15 and links 17 17' occurs, which causes a retraction of the feed-plate 6, and opens the aperture 9 in the side plate of the weapon in readiness for the expulsion of the empty shell. The pull on the trigger is continued and as the latter rises the slot 29 in the supplemental hammer contacts with the transverse pin 30, when the main hammer now starts, the two hammers from this point acting as a unit. This rearward oscillation of the main hammer carries with it the extractor, now grasping the empty shell. As the latter is withdrawn from the barrel it rests upon the top of the extractor 23. In order to direct said shell in the proper direction and cause it to pass out through the aperture 9, a bevel or inclined surface 54 is given the back of the extractor. (See Fig. 9.) When the trigger has attained its full backward movement, the mainspring has passed to a point above the pivot 26, and the tension of the spring is now exerted to hold the hammer and its co-operating parts in their retracted position, while the trigger is still free to move. At this moment (see Fig. 4) the free end of the extractor is held positively depressed, since the point 39 on the supplemental plate 21 is in contact with the shoulder 38 on said extractor. Cessation of pull on the trigger and release of the same allows it to return to its first position through the action of its spring 18. This act has again operated the lever 15 and caused the feed-plate 6 to rise, thereby advancing the cartridges in the magazine, and thrusting the

uppermost one across the top of the hammer, as likewise over the extractor, and at the same time closing the aperture 9 in advance and compelling said cartridge to enter the bore of the barrel. The partial release of the trigger has carried with it the fly, which has been freed from the action of the spring 47', whose duty was to hold said fly in the cocking-notch, and said fly is now influenced by the corresponding spring 47, which thrusts it in an opposite direction. Thus it will be understood that when the trigger is again pulled back the fly, now in the firing-notch, is operating the supplemental hammer upon the opposite side, and a continued pull now advances the hammer until the mainspring passes the center, when the said spring exerts an opposite force and the hammer is suddenly and forcibly carried against the cartridge. At this moment, or just prior to the discharge by the fall of the hammer, the latch 31 is released and locks the hammer, which closes the breech and acts as a breech-block. The parts will then have assumed the relative positions shown in Fig. 5, where it will be seen that the fly is just in the act of swinging forward to engage the cocking-notch 27.

In Fig. 2 it will be seen that the hammer is there held cocked by means of the mainspring, while the empty shell is just passing through the aperture 9. Furthermore, the trigger is in the act of swinging forward, due to a relaxation of the pull, and the fly has separated from the supplemental hammer, while the feed-plate and the cartridge next in readiness for discharge are about to move forward.

In Fig. 9 I have shown a novel form of firing-pin, adapted for either central or rim fire, as may be desired. This I accomplish by recessing the front face of the main hammer and inserting a firing-pin 25. This latter is adapted to be rotated axially, if so desired, and hence a transverse slot 56 is cut in the head, while the shank of the said pin is grooved to admit a fastening-pin 57. (See Fig. 4.) A boss or stud 58 is preferably cast upon the face of the firing-pin. Hence by axial rotation of said pin such adjustments are obtained as will enable the hammer to serve either for central or rim fire cartridges, the axial motion of the firing-pin changing the boss 58 to a point either central of a cartridge or circumferentially to the edge of the rim.

What I claim is—

1. In fire-arms a hammer adapted to serve as a breech block, comprising a hammer, and a rocking plate within the hammer, said plate arranged to have independent movement in advance of the hammer, combined with an extractor mounted on and carried by the hammer, said extractor being rendered active or inactive by the movements of the rocking plate, substantially as specified.

2. In fire arms, a slotted hammer, a firing-pin thereupon, a push pin movable in the hammer, and a locking bolt operated by the push-pin, combined with a rocking plate, a

pivot common to the hammer and the plate, interconnecting mechanism to allow movement of the rocking plate in advance of the hammer, a trigger, and a fly to alternately engage the cocking and firing notches formed in the rocking plate, substantially as stated.

3. In fire-arms the combination with a hammer, a rocking plate located within the hammer, and cocking and firing notches formed in the rocking plate, of a trigger, and a fly operated by oppositely disposed springs and arranged to alternately engage the cocking and firing notches in the rocking plate on different sides of the hammer pivot, substantially as described.

4. In magazine fire-arms a curved feeder-plate attached to the trigger and operated by the trigger spring to advance the cartridge forward, substantially as explained.

5. In magazine fire-arms the combination with a magazine having laterally notched wall plates adapted to feed the loaded cartridges upwardly into the breech of the weapon, of a sliding gate which serves to close the entrance to the magazine, and an interior lug affixed upon the gate and adapted to raise the cartridge last entered and cause said cartridge to engage the lowest notches in the magazine walls in the act of closing the magazine by the gate, as stated.

6. In fire arms, a curved magazine having notched wall plates, one stationary, the other movable, an operating trigger, and interconnecting levers by which the trigger in cocking the weapon causes retreat of said movable plate, as explained.

7. In fire-arms the combination with an apertured side plate for passage of empty shells, and a magazine formed with notched wall plates, one fixed the other adapted to reciprocate, of a trigger connected with said movable wall plate and adapted to positively withdraw said wall plate and open the shell aperture after discharge of the weapon, substantially as stated.

8. In fire-arms an extractor beveled transversely along its top edge and adapted to seize an empty shell and direct the latter through an aperture arranged for this purpose.

9. In fire-arms a hammer which serves as a breech-block, and a plate rocking within the hammer and both upon the same pivot, combined with a rocking extractor carried on the hammer, an ear 34 upon the rocking plate to engage said extractor and positively raise the extractor in the act of rocking the weapon, substantially as described.

10. In combination with a hammer, a rocking plate, both upon the same pivot, and an operating trigger, an extractor pivotally on the hammer, a notch 37 on one side of its pivot, and a lip 38 upon the opposite side, said notch and lip to engage respectively a tooth 36, and a shoulder 39 upon the rocking plate, whereby upon rocking of said hammer, the extractor is first raised to clasp an empty shell and then depressed to allow a loaded cartridge to pass

over it into the barrel, substantially as explained.

5 11. In fire-arms the combination with a hammer adapted to serve as a breech-block, and a rocking plate which operates the hammer by means of the trigger and both on a common pivot, of an operating trigger, a fly which engages the firing and rocking notches on the hammer, and two springs which control the
10 movement of the fly and are placed alternately under tension by the movements of the hammer in the acts of cocking or firing the weapon, substantially as specified.

15 12. In fire-arms the combination with a hammer adapted to serve as a breech-block, and a trigger for operating the same, of a fly which engages the cocking and firing notches in the hammer, a fixed stop in the side plate of the weapon, and means for causing the fly
20 to engage the stop, whereby the trigger is permitted only partial movement in the discharge of the weapon, substantially as described.

25 13. The combination with a hammer, a trigger for operating the same, and a spring-actuated carrier slide for feeding cartridges, of

mechanism which unites the said slide with the trigger, an oscillating fly carried by the trigger, and a fixed stop which engages said fly in the discharge of the weapon and thereby limits the travel of said slide, substantially as
30 set forth.

14. In fire arms the combination with a hammer, a carrier slide for feeding cartridges, a trigger which operates said hammer and slide, and mechanism which unites the slide
35 and trigger, of an oscillating fly carried by the trigger and adapted to engage the hammer, and a fixed stop so positioned upon the side plate of the weapon that the fly can engage therewith only when said fly is in one extreme
40 of position, whereby a full movement of the trigger is permitted in cocking the hammer and a partial movement of said trigger in the release of the hammer substantially as stated.

In testimony whereof I affix my signature
45 in presence of two witnesses.

HENRY F. WHEELER.

Witnesses:

JOHN F. NELSON,
H. E. LODGE.