

No. 811,675.

PATENTED FEB. 6, 1906.

G. H. TERRY.  
CEMENT FENCE POST MOLD.  
APPLICATION FILED MAR. 16, 1905.

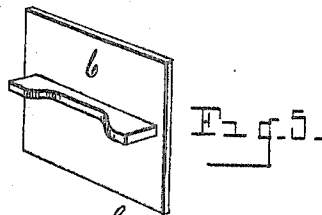
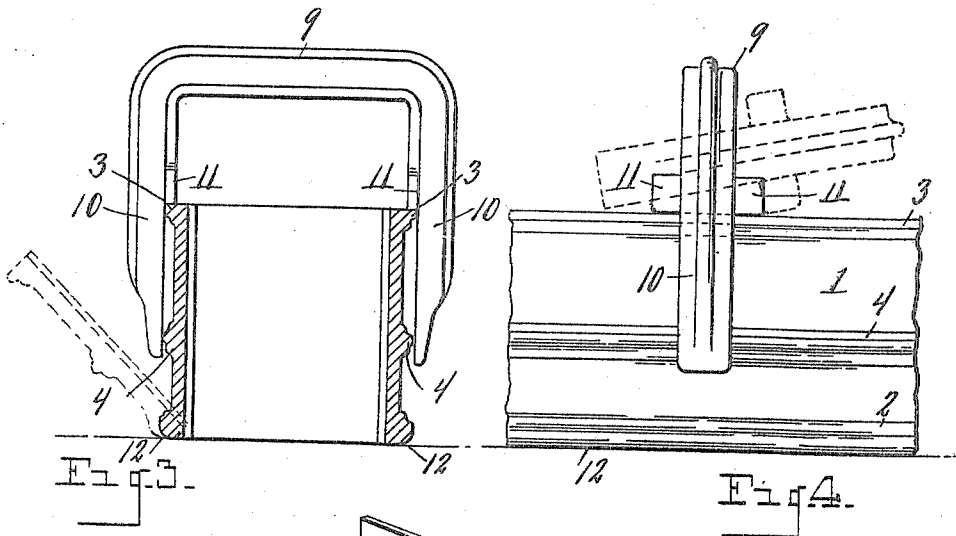
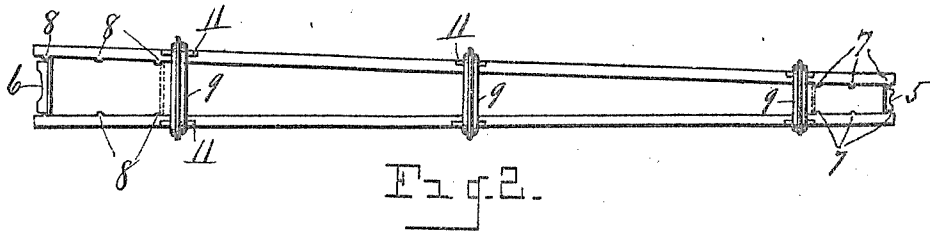
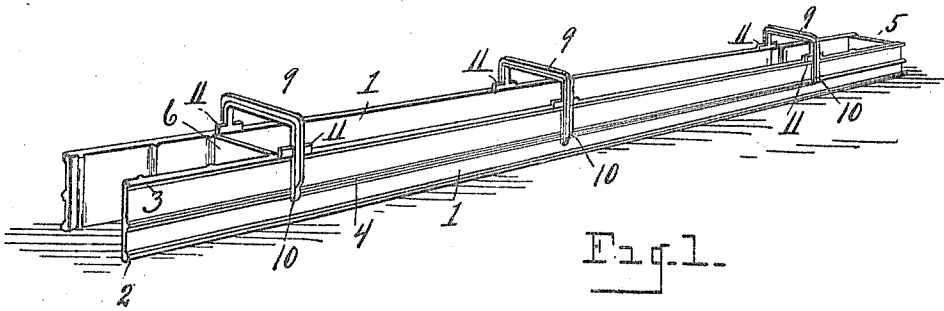

Witnesses:  
O. B. Baenzger,  
J. H. Howlett.

By his Attorneys  
George H. Terry,  
E. Wheeler & Co.

# UNITED STATES PATENT OFFICE.

GEORGE H. TERRY, OF LESLIE, MICHIGAN, ASSIGNOR, BY DIRECT AND MESNE ASSIGNMENTS, TO THE ECONOMY CEMENT POST MACHINE COMPANY, OF LESLIE, MICHIGAN, A CORPORATION OF MICHIGAN.

## CEMENT-FENCE-POST MOLD.

No. 811,675.

Specification of Letters Patent.

Patented Feb. 6, 1906.

Application filed March 16, 1905. Serial No. 250,353.

To all whom it may concern:

Be it known that I, GEORGE H. TERRY, a citizen of the United States, residing at Leslie, in the county of Ingham, State of Michigan, have invented certain new and useful Improvements in Cement-Fence-Post Molds; and I do declare the following to be a full, clear, and exact description of the invention, such as will enable others skilled in the art to which it appertains to make and use the same, reference being had to the accompanying drawings, and to the figures of reference marked thereon, which form a part of this specification.

This invention relates to cement-fence-post molds; and it consists in the construction and arrangement of parts hereinafter fully set forth, and pointed out particularly in the claims.

The objects of the invention are to provide simple and efficient means for molding fence-posts of cement, the arrangement being such as to enable the mold to be quickly placed in position, the fence-post shaped therein, and the mold at once removed without disturbing the post, said mold being adapted to be again set up to mold a succeeding post, and so on, the same mold being adaptable for molding as many posts as desired.

A further object is to provide a mold of the character described of light, strong, and durable structure so formed as to insure rigidity in the sides thereof, obviating all springing or warping of the sides and enabling the molding of any number of posts desired of unvarying form.

A further object is to provide for varying the length and also the diameter of the posts and also to provide for clamping the sides upon the end gates in a manner to allow said sides to be readily removed after the post is formed.

The above objects are attained by the construction illustrated in the accompanying drawings, in which—

Figure 1 is a perspective view of my improved mold in position for use. Fig. 2 is a plan view of Fig. 1. Fig. 3 is an enlarged transverse section through the sides of the mold. Fig. 4 is a fragmentary view in elevation, showing by dotted lines the manner of

removing the clamping-yokes. Fig. 5 is a perspective view of one of the end gates.

Referring to the characters of reference, 1 designates the sides of the mold, which are preferably formed of comparatively thin metal to render them sufficiently light for handling and which are provided with the longitudinally-extending strengthening-flanges 2 and 3 at the top and bottom, respectively, and the interposed longitudinally-extending strengthening-bead 4. By means of the strengthening bead and flanges the side is rendered sufficiently rigid to prevent it from springing laterally, thereby insuring a uniform shape to the posts. Interposed between the sides is the upper end gate 5 and the lower end gate 6.

It will be noted that the sides of the mold taper from the lower toward their upper ends and that the lower end gate 6 is correspondingly larger than the upper end gate. By reason of the taper to the sides of the mold and the difference in the sizes of the upper and lower end gates the post formed in the mold is rendered equally tapering on all sides. The end gates are supported against the opposed beads or shoulders 7 and 8, formed upon the inner faces of the sides at their upper and lower ends, respectively. By having a plurality of said beads or stop-shoulders the post may be varied in length and also varied in transverse diameter.

To make a post of the largest possible diameter, the end gate 6 at the base of the mold is placed against the stops 8 at the extreme ends of the sides and the upper end gate 5 is placed against the lower of the upper stops 7, as shown by dotted lines in Fig. 2.

In ordinary use the end gates will be placed as shown in Fig. 1, the upper end gate against the stops at the extreme upper ends of the sides and the lower end gate against the uppermost stops 8 at the lower ends thereof.

To provide for clamping the sides together so as to hold them in position when the cement is being placed therein, there are employed a plurality of U-shape yokes or clamps 9 of various sizes adapted to engage over the sides of the mold at a point where the mold is sufficiently narrow to allow the parallel side arms 10 of the clamps to pass thereover, when

by sliding the clamps toward the larger end of the mold they may be made to tighten thereon and securely hold the sides against expansion.

It will be noted on referring to Fig. 3 that the lower ends of the side arms 10 of the clamps engage the bead 4 on the sides of the mold, while the central portions of said arms engage the upper flanges 3. By this arrangement the sides are held at their bottom edges as well as at their top edges and are prevented from springing outwardly at the bottom when the plastic cement mixture is being tamped therein. Each of the clamps is provided upon the depending arms thereof with the transverse bars 11, which bear upon the upper flanges 3 of the sides and hold the clamps in an upright position, the ends of said bars also affording a fulcrum-bearing to enable the clamps to be pried off of the sides after the post has been formed by forcing the upper part of the clamp sidewise, as shown by dotted lines in Fig. 4.

On referring to Fig. 3 it will be noted that the bottom edges of the sides are slightly rounded, as at 12, whereby they are caused to tip outwardly when the clamps are removed therefrom, enabling them to be easily removed.

In using this mold it is only necessary to find a smooth surface, such as a barn-floor or other convenient place where the molded posts may be left to season. The mold is then set up upon this floor or surface with the end gates between the sides so positioned as to form the size of post required. The plastic cement mixture is then placed in the mold and tamped to cause it to perfectly fill the same, when the clamps are removed, enabling the sides and ends to be taken away and again set up for a succeeding operation,

the formed posts remaining undisturbed until such time as they shall have become sufficiently seasoned to allow handling.

Having thus fully set forth my invention, what I claim as new, and desire to secure by Letters Patent, is—

1. A cement-fence-post mold, comprising the opposed flaring sides, each of said sides having marginal strengthening-flanges, and a longitudinally-extending strengthening-bead interposed between said flanges and the clamping-yokes adapted to embrace the sides and to bear upon said strengthening-flanges and said bead.

2. A mold for cement fence-posts, comprising the opposed tapering sides arranged to diverge and having strengthening-flanges, the end gates movably located between said divergent sides, a plurality of clamping-yokes of various sizes adapted to embrace said sides between their ends, and to slide into binding relation therewith.

3. A mold for cement fence-posts comprising the converging metallic sides, having strengthening-flanges at their margins, and a longitudinally-extending strengthening-bead interposed between said flanges, movable end gates located between said sides, clamping-yokes adapted to embrace the sides and to bear against the flanges and beads, there being upon said yokes a supporting cross-bar adapted to rest upon the upper flanges of the sides.

In testimony whereof I sign this specification in the presence of two witnesses.

GEORGE H. TERRY.

Witnesses:

E. S. WHEELER,  
I. G. HOWLETT.