

(19) World Intellectual Property Organization
International Bureau



(43) International Publication Date
10 May 2012 (10.05.2012)

PCT

(10) International Publication Number
WO 2012/061549 A2

(51) International Patent Classification:
H04N 13/00 (2006.01) *H04N 13/02* (2006.01)

(21) International Application Number:
PCT/US2011/059057

(22) International Filing Date:
3 November 2011 (03.11.2011)

(25) Filing Language: English

(26) Publication Language: English

(30) Priority Data:
61/409,664 3 November 2010 (03.11.2010) US

(71) Applicant (for all designated States except US): **3DME-DIA CORPORATION** [US/US]; 1005 Slater Road, Suite 300, Durham, NC 27517 (US).

(72) Inventors; and

(75) Inventors/Applicants (for US only): **FELTEN, John, James** [US/US]; 615 Cedar Run Lane, Chapel Hill, NC 27516 (US). **MCNAMER, Michael** [US/US]; 21 Deerfield Road, Apex, NC 27523 (US). **MARKAS, Tassos** [US/US]; 10399 Holt, Chapel Hill, NC 27517 (US).

(74) Agent: **OLIVE, Bentley, J.**; Olive Law Group, PLLC, 130 Edinburgh South Drive, Suite 107, Cary, NC 27511 (US).

(81) Designated States (unless otherwise indicated, for every kind of national protection available): AE, AG, AL, AM, AO, AT, AU, AZ, BA, BB, BG, BH, BR, BW, BY, BZ, CA, CH, CL, CN, CO, CR, CU, CZ, DE, DK, DM, DO, DZ, EC, EE, EG, ES, FI, GB, GD, GE, GH, GM, GT, HN, HR, HU, ID, IL, IN, IS, JP, KE, KG, KM, KN, KP, KR, KZ, LA, LC, LK, LR, LS, LT, LU, LY, MA, MD, ME, MG, MK, MN, MW, MX, MY, MZ, NA, NG, NI, NO, NZ, OM, PE, PG, PH, PL, PT, QA, RO, RS, RU, RW, SC, SD, SE, SG, SK, SL, SM, ST, SV, SY, TH, TJ, TM, TN, TR, TT, TZ, UA, UG, US, UZ, VC, VN, ZA, ZM, ZW.

(84) Designated States (unless otherwise indicated, for every kind of regional protection available): ARIPO (BW, GH, GM, KE, LR, LS, MW, MZ, NA, RW, SD, SL, SZ, TZ, UG, ZM, ZW), Eurasian (AM, AZ, BY, KG, KZ, MD, RU, TJ, TM), European (AL, AT, BE, BG, CH, CY, CZ, DE, DK, EE, ES, FI, FR, GB, GR, HR, HU, IE, IS, IT, LT, LU, LV, MC, MK, MT, NL, NO, PL, PT, RO, RS, SE, SI, SK, SM, TR), OAPI (BF, BJ, CF, CG, CI, CM, GA, GN, GQ, GW, ML, MR, NE, SN, TD, TG).

Published:

— without international search report and to be republished upon receipt of that report (Rule 48.2(g))



WO 2012/061549 A2

(54) Title: METHODS, SYSTEMS, AND COMPUTER PROGRAM PRODUCTS FOR CREATING THREE-DIMENSIONAL VIDEO SEQUENCES

(57) Abstract: Methods and systems for creating three-dimensional video sequences of a scene are disclosed. An example method can include receiving multiple frames of a scene. The method may include selecting a target frame from among the multiple frames; selecting a first subset of frames, N, from among the multiple frames that are associated with the target frame that is representative of a large stereo baseline; and analyzing the first frame subset to identify two images for forming a stereoscopic pair of frames. Further, the method includes extracting depth data of static objects in the stereoscopic pair. The method includes selecting a second subset of frames that are associated with the target frame that is representative of a smaller stereo baseline than that represented by N; and utilizing the second frame subset to calculate depth of moving objects. The method includes generating a three-dimensional video frame based on the depth data.

DESCRIPTION

METHODS, SYSTEMS, AND COMPUTER PROGRAM PRODUCTS FOR CREATING THREE-DIMENSIONAL VIDEO SEQUENCES

CROSS REFERENCE TO RELATED APPLICATION

[0001] This application claims the benefit of U.S. provisional patent application serial number 61/409,664, filed November 3, 2010; the disclosure of which is incorporated herein by reference in its entirety.

TECHNICAL FIELD

[0002] The subject matter disclosed herein relates to generating a video sequence of a scene. In particular, the subject matter disclosed herein relates to methods, systems, and computer program products for using a two-dimensional video sequence of a scene to create a three-dimensional video sequence of the scene.

BACKGROUND

[0003] Stereoscopic, or three-dimensional, video is based on the principle of human vision. Video is a sequence of captured images (or frames), each of which, when combined with camera displacement, can record the same object(s) or new objects from slightly different angles. In such case, the captured sequence can then be transferred to a processor that may assign the captured sequence as the view for one eye (i.e., left or right eye), may analyze the individual frames and possibly interpolate additional frames/frame views, and may, for each frame generate a corresponding view for the other eye. The two resulting video sequences may then be combined to create a three-dimensional video sequence. The resulting three-dimensional video sequence can further be encoded using, but not limited, to one of the popular video encoding formats such as motion JPEG, MPEG, H.264, and the like. The video sequence can further be stored with audio to a digital media using a format such as, but not limited to, .avi, .mpg, and the like.

[0004] Many techniques of viewing stereoscopic video have been developed and include the use of colored or polarizing filters to separate the two views, temporal selection by successive transmission of video using a shutter arrangement, or physical separation of the two views in the

viewer and projecting them separately to each eye of a viewer. In addition, display devices have recently been developed that are well-suited for displaying stereoscopic images and videos. For example, such display devices include, but are not limited to, digital still cameras, personal computers, digital picture frames, set-top boxes, high-definition televisions (HDTVs), and the like.

[0005] The use of digital image capture devices, such as, but not limited to, digital still cameras, digital camcorders (or video cameras), and phones with built-in cameras, for use in capturing digital images has become widespread and popular. Because video sequenced captured using these devices are stored in a digital format, such video can be easily distributed and edited. For example, the videos can be easily distributed over networks, such as the Internet. In addition, the videos can be edited by use of suitable software on the image capture device or a personal computer.

[0006] Video sequences captured using conventional single lens, single sensor image capture devices are inherently two-dimensional. While dual lens/sensor combinations can be used to create three-dimensional content, it is desirable to provide methods and systems for using these conventional devices for generating three-dimensional videos.

SUMMARY

[0007] Methods, systems, and computer program products for creating three-dimensional video sequences of a scene are disclosed herein. Particularly, embodiments of the presently disclosed subject matter can include a method that uses a processor and memory for receiving a two-dimensional video sequence of a scene. The two-dimensional video sequence can include multiple frames. The method may also include selecting a target frame, T, from among the multiple frames. Further, the method may include selecting a first subset of frames representative of a large camera displacement, N, from among the multiple frames that are associated with the target frame T. The method may also include analyzing the first subset of frames to identify two images for use in forming a stereoscopic pair of frames with a predetermined spatial difference. Further, the method may include extracting depth data of static objects in the stereoscopic pair of frames. The method may also include selecting a second subset of frames representative of a small camera displacement, n ($n \ll N$), from among the multiple frames that are associated with T. The method may include utilizing the second subset of frames to calculate depth of moving objects. The method may also include combining the static and moving objects based on the depth data. Further, the method may include generating a three-

dimensional video frame corresponding to the target frame based on the depth data.

[0008] The Summary is provided to introduce a selection of concepts in a simplified form that are further described below in the Detailed Description. This Summary is not intended to identify key features or essential features of the claimed subject matter, nor is it intended to be used to limit the scope of the claimed subject matter. Furthermore, the claimed subject matter is not limited to any limitations that solve any or all disadvantages noted in any part of this disclosure.

BRIEF DESCRIPTION OF THE DRAWINGS

[0009] The foregoing summary, as well as the following detailed description of various embodiments, is better understood when read in conjunction with the appended drawings. For the purposes of illustration, there is shown in the drawings exemplary embodiments; however, the present subject matter is not limited to the specific methods and instrumentalities disclosed. In the drawings:

[0010] FIG. 1 is a front view of a user holding a camera and moving the camera for creating an initial panning sequence of a scene in accordance with embodiments of the present subject matter;

[0011] FIG. 2 is a diagram depicting a top view of an example panning sequence that may be implemented by use of an image capture device in accordance with embodiments of the present subject matter;

[0012] FIG. 3 is a block diagram of an example image capture device including an image sensor and a lens for use in capturing a two-dimensional video sequence of a scene according to embodiments of the presently disclosed subject matter;

[0013] FIGs. 4A and 4B depict a flow chart of an example method for creating a three-dimensional video sequence of a scene using the image capture device, alone or together with any other suitable device, in accordance with embodiments of the present disclosure;

[0014] FIGs. 5A and 5B depict a flow chart of an example method for creating a three-dimensional video sequence of a scene in accordance with embodiments of the present subject matter;

[0015] FIG. 6 is an example method for depth creation according to an embodiment of the present subject matter;

[0016] FIG. 7 is a flow chart of an exemplary method for depth creation using a macro-stereo based technique according to an embodiment of the present subject matter;

[0017] FIG. 8 is a flow chart of an example method for depth creation using a micro-stereo based technique according to an embodiment of the present subject matter;

[0018] FIG. 9 is a diagram showing depth calculation using a micro-based technique in accordance with an embodiment of the present subject matter;

[0019] FIG. 10 illustrates diagrams of a micro stereo based technique using frame-by-frame analysis in accordance with an embodiment of the present subject matter; and

[0020] FIG. 11 illustrates an exemplary environment for implementing various aspects of the subject matter disclosed herein.

DETAILED DESCRIPTION

[0021] The subject matter of the present subject matter is described with specificity to meet statutory requirements. However, the description itself is not intended to limit the scope of this patent. Rather, the inventors have contemplated that the claimed subject matter might also be embodied in other ways, to include different steps or elements similar to the ones described in this document, in conjunction with other present or future technologies. Moreover, although the term “step” may be used herein to connote different aspects of methods employed, the term should not be interpreted as implying any particular order among or between various steps herein disclosed unless and except when the order of individual steps is explicitly described.

[0022] Methods, systems, and computer programs products for creating three-dimensional video sequences are disclosed. According to an aspect, a method includes receiving a two-dimensional video sequence of a scene. For example, a camera or other image capture device may capture the two-dimensional video sequence. The two-dimensional video sequence can include a plurality of frames. The method also includes selecting a target frame from among the plurality of frames. Further, the method includes selecting a subset of frames from among the plurality of frames that are associated with the target frame. The method also includes determining a depth of the scene based on the target frame and the subset of frames. Further, the method includes generating a three-dimensional video frame corresponding to the target frame and based on the determined depth.

[0023] Embodiments of the present subject matter relate to an image capture device, such as a camera, that allows a user to capture a two-dimensional video sequence or use a stored two-dimensional video sequence for generating a three-dimensional video sequence based on the two-

dimensional video sequence. The functions disclosed herein can be implemented in hardware, software, and/or firmware that can be executed within the image capture device. Example image capture devices include, but are not limited to, a digital still camera, a video camera (or camcorder), a personal computer, a digital picture frame, a set-top box, an HDTV, a phone, and the like.

[0024] According to one or more other embodiments of the present subject matter, a method can include use of macro stereo base- techniques (i.e., utilizing two or more frames captured at a large horizontal displacement of the capture device in the original video sequence) to create a very accurate representation of the background and the non-moving objects on the scene. Further, the method can include the use of micro stereo base techniques (i.e., utilizing two or more frames captured at a small horizontal displacement of the capture device in the original video sequence) to create a very accurate representation of close as well as moving objects. Such three-dimensional video sequences can be viewed or displayed on a suitable stereoscopic display.

[0025] The functions and methods described herein can be implemented on an image capture device capable of capturing still images and executing computer executable instructions or computer readable program code on a processor. The image capture device may be, for example, a digital still camera, a video camera (or camcorder), a personal computer, a digital picture frame, a set-top box, an HDTV, a phone, or the like. The functions of the image capture device may include methods for selecting video segments, creating corresponding views for each image in the sequence, rectifying and registering at least two views, matching the color and edges of the views, performing stabilization of the sequence, altering the perceived depth of objects, and display-specific transformation to create a single, high-quality three-dimensional video sequence.

[0026] Image capture devices as disclosed herein may be utilized in various types of shooting modes for capturing a video sequence. In an example shooting mode, a video camera may remain static. For example, the video camera may be mounted on a tripod or otherwise kept stationary during image capture. A user may control the video camera to capture images of an event that is fully or partially contained within a fixed field of view of the video camera. The video camera may pan left, right, or another suitable direction for capturing panoramic scenery of the event.

[0027] In another example shooting mode, a user may hold the camera during use of the camera to capture images of an event. The event may be fully or partially contained within a fixed field of view of the camera. In contrast with the aforementioned example of using a tripod or

otherwise keeping the camera stationary, the camera may not be kept perfectly static in this example, because it can be difficult for someone holding the camera to keep it still. In this case, there may be some vertical and/or horizontal movement even if anti-shaking techniques are implemented on the camera.

[0028] In yet another example shooting mode, a user may pan the camera or move in various directions to either follow an object that is moving from the camera's field of view, or to refocus on a different object within the same field of view. The panning movement may be a parallel and/or rotating movement of the camera.

[0029] According to an embodiment, a method may include utilizing macro stereo base techniques to estimate depth when there is a significant movement of the camera. The results from the micro stereo base techniques may be further used in conjunction with the macro stereo base results to estimate the depth of a scene when the movement of the camera is very small.

[0030] In an embodiment, a first step in creation of a stereoscopic sequence is to define an initial three-dimensional representation of a scene or environment. Once a three-dimensional static space has been defined, moving objects may be identified. A depth of the moving objects can be estimated. Further, the objects may subsequently be placed a suitable depth in the previously constructed scene. The moving objects may be tracked while they are moving into the scene, and the location of the objects may be adjusted accordingly. Other objects may enter the field of view, or other static objects may appear on the scene as a result of camera panning. These other objects may also be detected and incorporated at a suitable depth into the scene.

[0031] FIG. 1 illustrates a front view of a user **100** holding a camera **102** and moving the camera **102** for creating an initial panning sequence of a scene (not shown) in accordance with embodiments of the present subject matter. A method of creating a three-dimensional video sequence of the scene may include creating a panning sequence of the scene by having a user move the camera in any direction (e.g., generally to the right or left). In this example, the user **100** is moving the camera **102** to his right as indicated by the direction arrow **104**. Alternatively, the user **100** may move the camera **102** to his left or any other suitable direction. As the camera **102** is moved, the camera **102** may capture a two-dimensional video sequence of the scene. The two-dimensional video sequence may include multiple frames of images. After the initial panning sequence has been completed, the user **100** can keep the camera **102** on the same field of view to continue capturing a moving object that

remains in the same place (i.e., a person talking), or the user **100** can move the camera **102** to re-center to either a different object, or to a new object entering or leaving the field of view. The captured video sequence, which can be a combination of the previously described shooting techniques, may be used for creating a three-dimensional video sequence in accordance with embodiments described herein.

[0032] FIG. 2 illustrates a diagram depicting a top view of an example panning sequence that may be implemented by use of an image capture device **200** in accordance with embodiments of the present subject matter. Referring to FIG. 2, the image capture device **200** is a camera positioned for capturing images of a background **202** of a scene. Objects **204** and **206** are positioned in a foreground area of the scene. In these positions, images of the objects **204** and **206** are also captured by the device **200**. In this example, the device **200** is moved or panned between a position generally referenced as **208**, where the device **200** is depicted by solid lines, and a position generally referenced as **210**, where the device **200** is depicted by broken lines. During panning between positions **208** and **210**, the device **200** captures and stores a two-dimensional video sequence of the scene. When the device **200** is located at position **208**, the device **200** captures one or more images of a field of view defined by lines **212** and **214**, which contains segments **216** through **218** of the background **202** of the scene, as well as images of the object **204** and part of the object **206**. When the device **200** is located at position **210**, the device **200** captures one or more images of a field of view defined by lines **220** and **222**, which contains segments **224** through **226** of the background **202** of the scene, as well an image of the object **206**.

[0033] Method embodiments described herein can be implemented on an image capture device capable of capturing still images and video sequences. The image capture device may also be capable of displaying three-dimensional images or videos, and executing computer readable program code on a processor. Such computer readable program code may be stored on a suitable computer readable storage medium. The image capture device may be, for example, a digital still camera, a video camera (or camcorder), a personal computer, a digital picture frame, a set-top box, an HDTV, a phone, or the like. As an example, FIG. 3 illustrates a block diagram of an example image capture device **300** including an image sensor **302** and a lens **304** for use in capturing a two-dimensional video sequence of a scene according to embodiments of the presently disclosed subject matter. Further, the image capture device **300** may include a video generator **306** configured to create three-dimensional video sequences in accordance with embodiments of the presently disclosed subject matter. In this

example, the image capture device **302** is capable of capturing a digital camera digital video of a scene. The image sensor **302** and lens **304** may operate to capture multiple consecutive still digital images of the scene. In another example, the image capture device **300** may be a video camera capable of capturing a video sequence including multiple still images of a scene. A user of the image capture device **300** may position the system in different positions for capturing images of different perspective views of a scene. The captured images may be suitably stored and processed for creating a three-dimensional video sequence of the scene as described herein. For example, subsequent to capturing the images of the different perspective views of the scene, the image capture device **300**, alone or in combination with a computer such as computer **306**, may use the images for creating a three-dimensional video sequence of the scene and for displaying the three-dimensional video sequence to the user.

[0034] Referring to FIG. 3, the image sensor **302** may include an array of charge coupled device (CCD) or CMOS sensors. The image sensor **302** may be exposed to a scene through the lens **304** and a respective exposure control mechanism. The video generator **306** may include analog and digital circuitry such as, but not limited to, a memory **308** for storing computer readable program code including computer readable code that controls the image capture device **300**, together with at least one CPU **310**, in accordance with embodiments of the presently disclosed subject matter. The CPU **310** executes the computer readable code so as to cause the image capture device **300** to expose the image sensor **302** to a scene and derive digital images corresponding to the scene. The digital images may be captured and stored in the memory **308**. All or a portion of the memory **308** may be removable, so as to facilitate transfer of the digital images to other devices such as the computer **306**. Further, the image capture device **300** may be provided with an input/output (I/O) interface **312** so as to facilitate transfer of digital image even if the memory **308** is not removable. The image capture device **300** may also include a display **314** controllable by the CPU **310** and operable to display the captured images in real-time for real-time viewing by a user. The display **314** may also be controlled for displaying the three-dimensional video sequences created in accordance with embodiments of the present subject matter.

[0035] The memory **308** and the CPU **310** may be operable together to implement the video generator **306** for performing image processing including generation of three-dimensional images in accordance with embodiments of the presently disclosed subject matter. The video generator **306** may control the image sensor **302** and the lens **304** for capturing a two-dimensional video sequence of a

scene. The video sequence may include multiple frames. Further, the video generator **306** may further process the images and generate a three-dimensional video sequence of the scene as described herein. FIGs. 4A and 4B illustrate a flow chart of an example method for creating a three-dimensional video sequence of a scene using the image capture device **300**, alone or together with any other suitable device, in accordance with embodiments of the present disclosure. Referring to FIGs. 4A and 4B, the method includes using **400** an image capture device to capture a two-dimensional video sequence of a scene. For example, the video generator **306** shown in FIG. 3 may control the image sensor **302** and the lens **304** to capture a two-dimensional video sequence of a scene. The captured video sequence may include images of the same or different perspective views of the scene. The CPU **310** may then implement computer readable code stored in the memory **308** for receiving and storing the captured video sequence in the memory **308**.

[0036] The method of FIGs. 4A and 4B includes selecting **402** a target frame from among frames of the captured video sequence. For example, the video generator **306** may select a target frame T from among multiple frames captured by the image sensor **302** and the lens **304**. The method of FIGs. 4A and 4B includes selecting **404** a first subset of frames, N, from among the plurality of frames that are associated with the target frame TN represents a desired macro stereo base offset of camera position from the position related to the target frame T, as measured by camera pose information gathered from the sequence or by camera positional sensor data. The method of FIGs. 4A and 4B includes analyzing **406** the first subset of frames to identify two images or frames for use in forming a stereoscopic pair of frames representative of the desired macro stereo baseline (predetermined spatial displacement of the capture device). For example, the video generator **306** may analyze the first subset of frames for identifying the two images or frames. The predetermined spatial difference may be such that the two images provide an optimal viewing of the scene.

[0037] The method of FIGs. 4A and 4B includes extracting **408** depth data of static objects via measurement of their pixel disparities in the stereoscopic pair of frames. For example, the video generator **306** may extract depth data of static objects in the stereoscopic pair of frames.

[0038] The method of FIGs. 4A and 4B includes selecting **410** a second subset of frames, n, from among the plurality of frames, N, that are representative of a substantially smaller stereo baseline separation of camera positions than is N. For example, the video generator **306** may select a second subset of frames from among multiple captured frames that are associated with the sequence of frames,

N.

[0039] The method of FIGs. 4A and 4B includes utilizing **412** the second subset of frames, **n**, to measure small disparities of and construct depth data for moving objects. For example, the video generator **306** may utilize the second subset of frames to calculate depth data of moving objects.

[0040] The method of FIGs. 4A and 4B includes combining **414** the static and moving objects based on the depth data. For each image, image warping techniques may be used, along with the two-dimensional capture data, to generate a suitable second view for a stereo pair. For example, the video generator **306** may combine the static and moving objects based on the depth data.

[0041] The method of FIGs. 4A and 4B includes generating **416** a three-dimensional video frame corresponding to the target frame based on the depth data. For example, the video generator **306** may generate a three-dimensional video frame corresponding to the target frame based on the depth data.

[0042] In an example, the method of FIGs. 4A and 4B may include one or more steps of identifying suitable frames, registration, stabilization, color correction, transformation, and depth adjustment. Further, the method may include generating one or more additional frames and frame viewpoints using one of existing raster data and depth information. Further, the method may include using a micro or macro stereo based technique for generating image representations of close and moving objects of the scene. A display, such as the display **314** or a display of the computer **306**, may display multiple three-dimensional video frames in a sequence.

[0043] FIGs. 5A and 5B illustrate a flow chart of an example method for creating a three-dimensional video sequence of a scene in accordance with embodiments of the present subject matter. The example method of FIGs. 5A and 5B may be implemented by any suitable image capture device, such as the image capture device **300** shown in FIG. 3. For example, the video generator **306** shown in FIG. 3 may control components of the image capture device **300** to implement the steps of the method of FIGs. 5A and 5B. Referring to Figure 5, the method includes segmenting **500** a video stream into panning sequences based on camera motion. In an example, such segmenting may include identifying instances in which a camera pans horizontally or vertically, instances in which the camera is still, combinations of these, and the like. Each instance of horizontal panning (alone or in part with other camera motion) may represent an instance of a macro stereo base, while still instances and instances dominated by only vertical motion may utilize micro stereo base. Sequences can be divided by

utilizing a combination of a scene change detection technique and camera pose information. Camera pose can be generated using any combination of any suitable on-board motion sensor data and suitable computer vision techniques that utilize camera calibrations matrices.

[0044] Subsequent to step 500, processing for each panning sequence is implemented as shown in FIGs. 5A and 5B. The processing of each panning sequence begins at step 502. For each target frame, T, a subset of frames, N, representing a desired horizontal displacement of the capture device, herein referred to as the macro stereo base can be identified. In the event that a given panning sequence does not displace the camera enough to reach the targeted stereo baseline, a lesser value may be used, provided it is representative of a macro stereo base, typically representing a distance at least as wide as typical human eye separation (6-7 cm), and preferably longer. Measurement of this displacement can be performed using either analysis of camera pose or using positional sensor data from the camera. Further, following step 502, processing for each video frame in the panning sequence is implemented in a process which begins at step 504. Once such panning sequence information is gathered, the resulting video segment can be used to create an accurate depth representation of the scene (step 506). The accuracy of these measurements may be further enhanced via interpolation (upsampling) of intermediate frame data, if needed. The captured video sequence can be partitioned in panning sequences that are processed separately (e.g., beginning at step 502). A new panning sequence can be defined when there is a significant or predetermined change on the rate at which the video sequence is captured (e.g., camera is panning, remaining static, accelerating/decelerating in one direction, and the like) and/or a significant change in the contents of the scene (e.g., objects passing into or out of view). In each panning sequence, the individual frames can be processed to determine the depth of the objects. For each frame, object segmentation can be performed to identify static and moving objects.

[0045] Extraction of the depth information can be a two-step process. During the first step, macro stereo base techniques can be used to identify depth of static objects. During the second step, micro stereo base techniques can be used to identify the depth of moving objects. FIG. 6 illustrates an example method for depth creation according to an embodiment of the present subject matter. Referring now to FIG. 6, the method includes segmenting video frames to moving and static objects (step 600). At step 602, the method includes using macro-stereo base techniques to estimate a depth of the static objects. At step 603, the method may include estimating the camera movement. At step 604,

the method includes using micro stereo base techniques to estimate depth of moving objects. Next, at step **606**, the method includes combining the estimated depths from the micro- and macro-stereo base techniques to create a depth map of a video frame.

[**0046**] Referring now to Figure 7, which illustrates a macro stereo base technique in accordance with embodiments of the present subject matter, the method includes identifying ideal stereo based of static objects (step **700**), which selects the subset of frames, N, from the current panning sequence of frames (step **702**). Further, the method includes registering the selected frames (step **704**) and calculating disparity (step **706**). The method also includes assigning depth on static objects (step **708**).

[**0047**] The initial panning sequence may include of collection of frames that are taking at different locations. Each symmetric pair of such collection can create a stereoscopic representation of static objects or subjects on the scene at different depths.

[**0048**] Objects that are relatively far from the capture device may require a larger stereo base (defined herein as a macro stereo base) to accurately estimate depth of the objects. Referring to FIG. 2 for example, and during the capture of a video sequence, N frames may have been captured between positions **208** and **210** of the image capture device **200**. Each pair of those frames around the center of the **208** and **210** positions can form a stereoscopic pair of different stereo base and therefore a different depth perception. For accurate representation of the depth, it may be more ideal that image capture device positions between positions **208** and **210** moves laterally without toeing out. Based on the example of FIG. 2, a pair of those frames may be used to create an initial three-dimensional representation of the space outlined by lines **214** and **220** that includes the segment between **218** and **224**, the object **204**, and a small portion of object **206**. By continuing this example method, other areas can be covered to generate a stereoscopic view of the area of interest. For example, FIG. 7 illustrates a flow chart of an exemplary method for depth creation using a macro-stereo based technique according to an embodiment of the present subject matter. For such a macro stereo base, measurement of the depth of individual objects may be accomplished by analyzing image pairs at an interval N, such that the interval is representative of a target stereo baseline, or by maintaining depth values of those same objects in the case that the capture device is no longer being displaced (between panning sequences). Image pairs are registered and processed by use of suitable techniques. The displacement, or disparity, of objects in the image pairs may then be measured and translated into depth under the general stereo

equation $n = \frac{Baseline * FocalLength}{disparity}$, where Baseline is the distance of camera movement in the interval

of N frames and FocalLength is the focal length of the camera lens. This macro-stereo base technique may allow identification of disparities of, and assign depth to, static objects in the scene. In an embodiment, a dense disparity map may be generated, producing a disparity result (and hence, a depth estimate) for each pixel in the frame. In another embodiment, in part because the calculation of a dense disparity map may be difficult, techniques using feature detection and tracking can be used to generate only a sparse disparity map for a subset of pixels. Additionally, moving objects may be identified and ignored during this process.

[0049] Returning to FIGs. 5A and 5B, the method may include a small stereo baseline (micro-stereo) analysis to calculate depth of moving objects and near objects for which disparity techniques are weak at larger stereo baselines(e.g., step **504**). Prior to micro-stereo analysis, the movement of the camera may be computed to increase the accuracy of the micro-stereo analysis since it relies on small camera movements (step **603** of FIG. 6).

[0050] For each frame in the sequence, camera movement can be recorded via a suitable module such as, but not limited to, a gyroscopic sensor residing in the camera. Another method of identifying the positioning of the camera includes analyzing two frames, identifying key points in both frames, rectifying and extracting the fundamental matrix relationship, and combining with camera parameters (focal length and the like) to generate the projective camera matrices for each position.

[0051] Analysis of the motion vectors of each pixel within the context of object segmentation can provide detailed information of the depth of a scene. Analysis of motion vectors of static objects, due to camera movement, can detect the movement of an image capture device. If an object is at the same depth, motion vectors of that object can accurately detect the lateral (horizontal and/or vertical movement of the camera). If parts of an object reside in various depths, the motion vectors of the individual pixels can accurately detect the rotational movement of the image capture device.

[0052] In an example, FIG. 8 illustrates a flow chart of an example method for depth creation using a micro-stereo based technique according to an embodiment of the present subject matter. This may be accomplished by analyzing image pairs at an interval M, such that $M \ll N$. The value of n may be the equivalent of the motion incurred in panning for 1/60 to 1/15 of a second. Each

pair of images may again be registered and processed with suitable techniques. Disparities of objects in the scene that may have been previously recognized as moving or non-static can be measured using the same general techniques and again, depths can be assigned. Since the camera movement during the interval of n frames may be relatively small, this represents a micro-stereo based approach that allows evaluation of object depth for non-static objects with a high degree of confidence, such as may not be possible by use of a macro-stereo technique, due to temporal latency. By also compensating for camera movement as described at step **303** of FIG. 6 can further improve the quality of micro-stereo analysis.

[0053] Referring now to FIG. 8, the method includes analyzing video frames between 1 and n , where n is less than N (step **800**). The method also includes selecting two video frames of distance n to match stereo base (step **802**). Further, the method includes registering the selected frames (step **804**). The method also includes calculating disparity (step **806**) and assigning depth of close objects and objects identified as moving (step **808**).

[0054] FIG. 9 illustrates a diagram showing depth calculation using a micro-based technique in accordance with an embodiment of the present subject matter. Referring to FIG. 9, a scene including a background area generally designated **900**, a moving object **902** (person), a static object **904** (window), and another static object **906** (base) is captured using a camera. During the initial panning sequence, two frames taken at times t and $t + H$ (indicated by frame **908** and **910**, respectively) have been used to construct the macro stereo base depth representation of the scene. The objects captured in the first frame **908** are designated by "a" (e.g., objects **902a**, **904a**, and **906a**), and the object captured in the second frame **910** are designated by "b" (e.g., objects **902b**, **904b**, and **906b**). The disparity between the moving object **902a**, **902b** in the frames **908** and **910** is indicated by D_m , the disparity between the static object **904a**, **904b** in the frames **908** and **910**, which is further in the back in the background **900** is indicated by D_w , and the disparity between the static object **904a**, **904b** is indicated by D_v . In this particular example, $D_m < D_v < D_w$.

[0055] During a panning sequence, if the object **902a**, **902b** is moving, a smaller stereo base technique can be used for the depth analysis. Under the micro stereo basis analysis shown on the right side of FIG. 9, two frames **912** and **914** that are close in time are examined (t and $t + h$, where h is much smaller than H). In such case, the movement of the object **902a**, **902b** is very small and conceptually static. In an example, motion estimation techniques may be used to compensate for the

motion of the moving object. By disabling any motion stabilization capabilities inside the camera, there can be some natural micro-stereo based because of handshaking and this can result in movement of the camera from positions **916** to **918** of the camera **901**. The process may be repeated multiple times with different values of n (where $n < h$) until a disparity value for each object identified as moving is available that discounts most or all of the motion of the object. It is noted that the disparity values may only be important in relative relation to the image, and need not represent specifically accurate disparity for each object.

[0056] Now referring back to FIGs. 5A and 5B at step **506**, at the point of having data from step **508** in FIGs. 5A and 5B and step **808** in FIG. 8, macro and micro stereo base information can be combined. Disparity information from the macro stereo base calculations is assigned to the objects identified as “non-moving” or distant, relative to a given camera separation represented by a set of frames, N . Disparity information must then be added for moving and close objects using the result from the micro analysis. For close objects, this may be performed simply by noting the disparity result(s) from step **808** and the ratio between the specific value of n used to assign the value and N . The disparity for these pixels can become the value from step **808** multiplied by the factor N/n .

[0057] In FIG. 9, a D_m ’ disparity of the object **902a**, **902b** can be compared with the D_w ’ disparity of the known static object **904a**, **904b** and the D_w disparity of the static object in the macro stereo base case.

[0058] For moving objects, the relative relationships of the same pixels in the different analyses may be relied upon. From the micro calculation (e.g., step **808**), a value of n can be identified for which a disparity can be assigned to the pixels in question. This disparity can have a relation to other pixels in the scene, and specifically, to pixels identified and placed in a previous video segment, or to pixels identified and placed at a particular static disparity in step **708**. For pixels that correspond to those placed in an earlier segment, the depth assigned in that segment can be extrapolated to the current segment, while recognizing a possibility of approach toward or retreat from the camera.

[0059] For pixels not previously assigned, the ratios of the depth and disparity of known objects can be used to place unknown object. Without loss of generality, a pixel classified as moving at coordinate (j, k) in the micro analysis can be assumed to have an assigned disparity d_1 for the selected frame M , and a pixel at coordinate (m, n) that has a static disparity D_2 for separation N in the macro analysis and a value of d_2 for the selected frame n in the micro analysis. The disparity assigned

this pixel in the final combined map can subsequently be calculated as $D_1 = D_2 * d_1/d_2$. Repetition of this process for multiple small intervals of n across a video segment can also be used to place approaching and retreating objects in a scene.

[0060] In one case, a suitable n may not be found, and other micro-based methods can be employed to calculate the depth of moving objects or movement of the camera. Utilization of those techniques may apply to values of n ranging from one to two. In other words, successive frames may be used to measure movement of various subjects.

[0061] At any given time, each of the above shooting modes can create movement of subjects that can be classified as of one of the following categories: absolute movement of objects on the scene; and movement of an image capture device that results into a movement of static objects on the scene (global motion for all static pixels on the scene) and a relative motion for the moving objects on the scene (global minus absolute motion). In the category of absolute movements of objects on the scene, this can be a three dimensional movement where objects travel in x , y , and z (i.e., depth) dimensions. In the category of movement of an image capture device, the movement of the camera can be three dimensional. Further, in this category, besides movement on the horizontal and vertical coordinates, movement on the depth (i.e., z -plane) can be caused by the actual camera moving closer or further away from the object or by utilizing the zoom capability of the image capture device. Further, movement of the image capture device can be either lateral or rotational.

[0062] Because the movement of an image capture device can be rotational, global motion may not be identical for all the static pixels on the scene. Pixels closer to the image capture device may have larger motion vectors and pixels far away from the image capture device may have smaller magnitude motion vectors compared to the closer objects. In addition, the movement of the image capture device cannot be constant and is expected that it can change over time. Therefore, at any given time each pixel (P) located in 'i' horizontal, a 'j' vertical, and a 'k' depth coordinates can potentially have a different static motion vector caused by image capture device movement $mvsx(t, i, j, k)$, $mvsy(t, i, j, k)$ and $mvsz(t, i, j, k)$ for horizontal, vertical, and z -plane movement, as well as absolute motion vector caused by the movement of the object ($mvmx(t, i, j, k)$, $mvmy(t, i, j, k)$ and $mvmz(t, i, j, k)$ for horizontal, vertical, and depth movements). Knowing the location of any static pixel (P_s) in a frame (t), its location in time ($t + 1$) can be found using the following equation:

$$P_s(t+1, i, j, k) = P_s(t, i + mv_{sx}(t, i, j, k), j + mv_{sy}(t, i, j, k), k + mv_{sz}(t, i, j, k) + mv_{mz}(t, i, j, k) \quad (\text{Equation 1})$$

[0063] Any moving pixel (P_m) in a frame ($t+1$) can be found in frame (t) using the following equation:

$$P_m(t+1, i, j, k) = P_m(t, i + mv_{sx}(t, i, j, k) + mv_{mx}(t, i, j, k), j + mv_{sy}(t, i, j, k) + mv_{my}(t, i, j, k), k + mv_{sz}(t, i, j, k) + mv_{mz}(t, i, j, k) \quad (\text{Equation 2})$$

[0064] The static motion vectors (mv_{sx} , mv_{sy} , mv_{sz}) can be calculated by analyzing the captured frames, identifying highly correlated static points on the images (P_s) rectifying and registering the frames, and then calculating the inverse registration transform that can result from the movement of those points into the three dimensional space (Equation 1).

[0065] Once the static motion vectors have been calculated, the absolute motion vectors (mv_{mx} , mv_{my} , mv_{mz}) can be calculated by performing the same operation for the P_m points using Equation (2).

[0066] By subsequently subtracting the static motion vectors from the combined motion vectors, the absolute motion vectors for moving objects in the scene can be obtained. With the present analysis, the camera movement, the static background, and the moving objects can be fully defined into the three-dimensional space.

[0067] Non-flying objects can have an anchor point which is the ground for most part of static object staying at the ground. The initial position of such objects is based on their anchor points to the ground. The ground, or in general any static object, can be placed on the three-dimensional space by using the following technique:

- First, the image can be analyzed to detect all static objects by looking at the disparity between two images comprising a stereo pair during macro stereo-base analysis;
- The image can be segmented into static objects in objects;
- In each object, key features can be identified that are also key features on a corresponding stereo pair during macro analysis; and
- The disparity of the key points provides a surface on the three dimensional space which is the static object.

[0068] For flying objects as well as non-flying in certain instances, their trajectory path can be identified and determine their path across other objects. If their path hides static objects, it can be

implied that they are in front of them. If their path places them behind objects, their path is behind objects.

[0069] In case there is no much movement on the camera (both laterally and rotationally), the background can remain constant, and its depth has already been estimated. For moving objects and once an initial estimate is obtained, utilize motion compensation techniques can be used to estimate the speed of the object in the horizontal and vertical dimensions, and the rate of scaling methods to estimate its speed on the z-plane. Based on those estimates, the proper depth representation can be created.

[0070] Returning to FIGs. 5A and 5B, the method further includes the dynamic adjustment of the background or static objects when user pans the camera left or right to maintain the high depth accuracy obtained using the large stereo base (step 508). This adjustment may be performed by looking at the depth map gradient of the different surfaces that comprise the background scene and interpolating based on the amount of movement.

[0071] The method of FIGs. 5A and 5B further includes the dynamic adjustment of moving objects (step 510). For example, the size of moving objects may be compared with the size on the previous frames and if the size gets larger it is appropriately adjusted on the depth map by taking in consideration the size of the increase and the time frame at which this increase took place. Similarly, if the object size gets smaller, it can be moved back on the depth plane with the amount that is appropriate based on the size of the decrease and the time for this decrease took place.

[0072] Once the lateral and rotational motion vectors of the camera have been estimated, the absolute motion vectors of the moving objects can also be estimated. The rate of increase of the size of a moving object determines its motion towards the camera (closer in depth) and the rate of decrease of the size determines the motion away from the camera (farther in depth).

[0073] According to an embodiment, rate of scaling is a technique where key features of an object are measured between successive frames. Upon approach or retreat of an object from the camera (or camera from the object), object motion vectors may be indicative of the movement. FIG. 10 illustrates diagrams of a micro stereo based technique using frame-by-frame analysis in accordance with an embodiment of the present subject matter. For an object 1000a at its position at time t , which is approaching the image capture device, its location at time $t + 1$ may be closer to the image capture device than when the object 1000b is at its location at time $t + 1$, and therefore it will appear larger.

For an object **1002a** at its position at time t and is retreating from the image capture device, its location at time $t + 1$ will be further away when the object **1002b** is at its location at time $t + 1$, and therefore it will appear smaller. For motion directly in line with the image capture device center, directionality of the mode measurements of pixel movement on the left, right, top, and bottom centers is indicative of the object (or camera) motion toward or away from the camera. Approaching motion may have a negative motion component on the left and top of the object, and positive on the right and bottom, such that the magnitude between left and right side vectors and between top and bottom vectors can increase. Retreating motion will have the opposite, such that the same magnitudes can decrease. Without loss of generality, any component of the object (or camera) motion that is away from the center line from the object to the camera can result in a translational component that may change the scale of the vectors, but will still maintain the magnitude change relationship. The rate of change these magnitudes, combined with a depth estimation, can be indicative of the velocity of this movement.

[0074] The combined motion vectors (MV) of moving objects, defined as objects comprising of pixels that do not follow the global motion movement, can be calculated using “rate of scaling” techniques to calculate motion vectors for movement in depth and traditional motion compensation methods to calculate movement in x and y coordinates. Enlargement of the measurements, during rate of scaling calculations, indicate that objects move closer to the camera, whereas smaller measurement indicate that objects move away from the camera. The rate of change also determines the motion vectors.

[0075] The method of FIGs. 5A and 5B further includes identification of occlusion zones resulting from the movement of objects in the scene (step **512**). Once the occlusion area is calculated, a search can be performed in adjacent frames to identify an accurate representation of such areas. If such areas do not exist, then occlusion zones can be calculated based on suitable techniques.

[0076] The method of FIGs. 5A and 5B further includes detection and placement of new objects in the depth plane (step **514**). New objects can appear on the scene by either panning the camera left or right, or the objects entering the scene because of their movement. Once a new object is detected, it can be determined whether the object is a static or moving object by, for example, analyzing the motion vectors of the object and comparing the vectors with the motion vectors of the still background objects (step **516**). If the objects are static, macro based techniques can be used to determine their depth and frames with large stereo base can be used to create their three-dimensional

representation (step **518**). If the objects are moving objects, micro based techniques can be used to determine their depth and frames with small stereo base can be used to create their three-dimensional representation after they have properly adjusted for motion (step **520**). The recognition of new “objects” entering a given scene may also trigger the creation of a new panning sequence.

[**0077**] The method of FIGs. 5A and 5B includes processing a next frame in the sequence, if there is another frame (step **522**). If there is another frame, the method proceeds to step **504**. Otherwise, the method includes combining the current panning sequence with the one before by equalizing depth and other 3D parameters (step **524**), as well as stabilizing for hand-shaking (step **525**), and then processing a next panning sequence, if there is another (step **526**). The method may then proceed to step **502** for another panning sequence.

[**0078**] The method of FIGs. 5A and 5B further includes combining the results from the macro- and micro-stereo base calculations to create a three-dimensional model for each frame in the panning sequence of a given scene, with the recognition that a given video sequence may include of multiple panning sequences, with depth equalization between them based on corresponding features (step **524**). Each raster pixel for a frame can have an assign (x,y,z) triplet, and can be transformed via perspective projection to a triplet (x',y',z') using a targeted angular rotation about the Y axis or similar view synthesis technique. The screen plane depth may initially be chosen or selected to create the axes for this rotation, and this may be done by selecting a depth from the range represented such that objects in front of the modeled plane are no further than X% of the planes distance closer to the viewer, with a typical value for X being 25%. The target angular rotation may be selected using an approximate viewing location and screen size for the final video, and is chosen to create an ideal stereo base representation of the entire scene and comfortable depth range for the viewer. In an embodiment, this depth range is viewer adjustable from the default settings previously calculated using the aforementioned parameters. Following this transform, multiple pixels are projected back to 2D space for viewing, with the recognition that some pixels may occupy the same space (meaning that the closer is viewed and the further is hidden), or that disparity/depth estimates may not exist for some pixels (in a sparse disparity map embodiment), such that some raster locations may not have assigned pixel values. In the latter case, pixel fill and interpolation methodologies, utilizing data available from previous or subsequent frames in the panning sequence may be performed.

[0079] The creation and presentation, such as display, of three-dimensional videos of a scene in accordance with embodiments of the present subject matter may be implemented by a single device or combination of devices. In one or more embodiments of the present subject matter, images may be captured by a camera such as, but not limited to, a digital camera. The camera may be connected to a personal computer for communication of the captured images to the personal computer. The personal computer may then generate one or more three-dimensional videos in accordance with embodiments of the present subject matter. After generation of the three-dimensional images, the personal computer may communicate the three-dimensional videos to the camera for display on a suitable three-dimensional display. The camera may include a suitable three-dimensional display. Also, the camera may be in suitable electronic communication with a high-definition television for display of the three-dimensional videos on the television. The communication of the three-dimensional videos may be, for example, via an HDMI connection.

[0080] In one or more other embodiments of the present subject matter, three-dimensional videos may be generated by a camera and displayed by a separate suitable display. For example, the camera may capture conventional two-dimensional images and then use the captured images to generate three-dimensional videos. The camera may be in suitable electronic communication with a high-definition television for display of the three-dimensional videos on the television. The communication of the three-dimensional videos may be, for example, via an HDMI connection.

[0081] The subject matter disclosed herein may be implemented by a suitable electronic device having one or more processors and memory, such as a digital still camera, a video camera, a mobile phone, a smart phone, phone, or the like. In order to provide additional context for various aspects of the disclosed subject matter, FIG. 11 and the following discussion are intended to provide a brief, general description of components of a suitable electronic device **1100** in which various aspects of the disclosed subject matter may be implemented. While the present subject matter is described in the general context of computer-executable instructions, such as program modules, executed by one or more computers or other devices, those skilled in the art will recognize that the disclosed subject matter can also be implemented in combination with other program modules and/or as a combination of hardware and software.

[0082] Generally, however, program modules include routines, programs, objects, components, data structures, etc. that perform particular tasks or implement particular data types. The

operating environment **1100** is only one example of a suitable operating environment and is not intended to suggest any limitation as to the scope of use or functionality of the subject matter disclosed herein. Other well-known computer systems, environments, and/or configurations that may be suitable for use with the subject matter include but are not limited to, personal computers, hand-held or laptop devices, multiprocessor systems, microprocessor-based systems, programmable consumer electronics, network PCs, minicomputers, mainframe computers, distributed computing environments that include the above systems or devices, and the like.

[0083] With reference to Figure 6, an exemplary environment **1100** for implementing various aspects of the present subject matter disclosed herein includes a computer **1102**. The computer **1102** includes a processing unit **1104**, a system memory **1106**, and a system bus **1108**. The system bus **1108** couples system components including, but not limited to, the system memory **1106** to the processing unit **1104**. The processing unit **1104** can be any of various available processors. Dual microprocessors and other multiprocessor architectures also can be employed as the processing unit **1104**.

[0084] The system bus **1108** can be any of several types of bus structure(s) including the memory bus or memory controller, a peripheral bus or external bus, and/or a local bus using any variety of available bus architectures including, but not limited to, 11-bit bus, Industrial Standard Architecture (ISA), Micro-Channel Architecture (MCA), Extended ISA (EISA), Intelligent Drive Electronics (IDE), VESA Local Bus (VLB), Peripheral Component Interconnect (PCI), Universal Serial Bus (USB), Advanced Graphics Port (AGP), Personal Computer Memory Card International Association bus (PCMCIA), and Small Computer Systems Interface (SCSI).

[0085] The system memory **1106** includes volatile memory **1110** and nonvolatile memory **1112**. The basic input/output system (BIOS), containing the basic routines to transfer information between elements within the computer **1102**, such as during start-up, is stored in nonvolatile memory **1112**. By way of illustration, and not limitation, nonvolatile memory **1112** can include read only memory (ROM), programmable ROM (PROM), electrically programmable ROM (EPROM), electrically erasable ROM (EEPROM), or flash memory. Volatile memory **1110** includes random access memory (RAM), which acts as external cache memory. By way of illustration and not limitation, RAM is available in many forms such as synchronous RAM (SRAM), dynamic RAM

(DRAM), synchronous DRAM (SDRAM), double data rate SDRAM (DDR SDRAM), enhanced SDRAM (ESDRAM), Synchlink DRAM (SLDRAM), and direct Rambus RAM (DRRAM).

[0086] Computer **602** also includes removable/nonremovable, volatile/nonvolatile computer storage media. Figure 6 illustrates, for example, disk storage **1114**. Disk storage **1114** includes, but is not limited to, devices like a magnetic disk drive, floppy disk drive, tape drive, Jaz drive, Zip drive, LS-100 drive, flash memory card, or memory stick. In addition, disk storage **1024** can include storage media separately or in combination with other storage media including, but not limited to, an optical disk drive such as a compact disk ROM device (CD-ROM), CD recordable drive (CD-R Drive), CD rewritable drive (CD-RW Drive) or a digital versatile disk ROM drive (DVD-ROM). To facilitate connection of the disk storage devices **1114** to the system bus **1108**, a removable or non-removable interface is typically used such as interface **1116**.

[0087] It is to be appreciated that FIG. 11 describes software that acts as an intermediary between users and the basic computer resources described in suitable operating environment **1100**. Such software includes an operating system **1118**. Operating system **1118**, which can be stored on disk storage **1114**, acts to control and allocate resources of the computer system **1102**. System applications **1120** take advantage of the management of resources by operating system **1118** through program modules **1122** and program data **1124** stored either in system memory **1106** or on disk storage **1114**. It is to be appreciated that the subject matter disclosed herein can be implemented with various operating systems or combinations of operating systems.

[0088] A user enters commands or information into the computer **1102** through input device(s) **1126**. Input devices **1126** include, but are not limited to, a pointing device such as a mouse, trackball, stylus, touch pad, keyboard, microphone, joystick, game pad, satellite dish, scanner, TV tuner card, digital camera, digital video camera, web camera, and the like. These and other input devices connect to the processing unit **1104** through the system bus **1108** via interface port(s) **1128**. Interface port(s) **1128** include, for example, a serial port, a parallel port, a game port, and a universal serial bus (USB). Output device(s) **1130** use some of the same type of ports as input device(s) **1126**. Thus, for example, a USB port may be used to provide input to computer **1102** and to output information from computer **1102** to an output device **1130**. Output adapter **1132** is provided to illustrate that there are some output devices **1130** like monitors, speakers, and printers among other output devices **1130** that require special adapters. The output adapters **1132** include, by way of

illustration and not limitation, video and sound cards that provide a means of connection between the output device **1130** and the system bus **1108**. It should be noted that other devices and/or systems of devices provide both input and output capabilities such as remote computer(s) **1134**.

[**0089**] Computer **1102** can operate in a networked environment using logical connections to one or more remote computers, such as remote computer(s) **1134**. The remote computer(s) **1134** can be a personal computer, a server, a router, a network PC, a workstation, a microprocessor based appliance, a peer device or other common network node and the like, and typically includes many or all of the elements described relative to computer **1102**. For purposes of brevity, only a memory storage device **1136** is illustrated with remote computer(s) **1134**. Remote computer(s) **1134** is logically connected to computer **1102** through a network interface **1138** and then physically connected via communication connection **1140**. Network interface **1138** encompasses communication networks such as local-area networks (LAN) and wide-area networks (WAN). LAN technologies include Fiber Distributed Data Interface (FDDI), Copper Distributed Data Interface (CDDI), Ethernet/IEEE 1102.3, Token Ring/IEEE 1102.5 and the like. WAN technologies include, but are not limited to, point-to-point links, circuit switching networks like Integrated Services Digital Networks (ISDN) and variations thereon, packet switching networks, and Digital Subscriber Lines (DSL).

[**0090**] Communication connection(s) **1140** refers to the hardware/software employed to connect the network interface **1138** to the bus **1108**. While communication connection **1140** is shown for illustrative clarity inside computer **1102**, it can also be external to computer **1102**. The hardware/software necessary for connection to the network interface **1138** includes, for exemplary purposes only, internal and external technologies such as, modems including regular telephone grade modems, cable modems and DSL modems, ISDN adapters, and Ethernet cards.

[**0091**] The various techniques described herein may be implemented with hardware or software or, where appropriate, with a combination of both. Thus, the methods and apparatus of the disclosed embodiments, or certain aspects or portions thereof, may take the form of program code (i.e., instructions) embodied in tangible media, such as floppy diskettes, CD-ROMs, hard drives, or any other machine-readable storage medium, wherein, when the program code is loaded into and executed by a machine, such as a computer, the machine becomes an apparatus for practicing the subject matter. In the case of program code execution on programmable computers, the computer will generally include a processor, a storage medium readable by the processor (including volatile and non-volatile

memory and/or storage elements), at least one input device and at least one output device. One or more programs are preferably implemented in a high level procedural or object oriented programming language to communicate with a computer system. However, the program(s) can be implemented in assembly or machine language, if desired. In any case, the language may be a compiled or interpreted language, and combined with hardware implementations.

[0092] The described methods and apparatus may also be embodied in the form of program code that is transmitted over some transmission medium, such as over electrical wiring or cabling, through fiber optics, or via any other form of transmission, wherein, when the program code is received and loaded into and executed by a machine, such as an EPROM, a gate array, a programmable logic device (PLD), a client computer, a video recorder or the like, the machine becomes an apparatus for practicing the subject matter. When implemented on a general-purpose processor, the program code combines with the processor to provide a unique apparatus that operates to perform the processing of the present subject matter.

[0093] While the embodiments have been described in connection with the preferred embodiments of the various figures, it is to be understood that other similar embodiments may be used or modifications and additions may be made to the described embodiment for performing the same function without deviating therefrom. Therefore, the disclosed embodiments should not be limited to any single embodiment, but rather should be construed in breadth and scope in accordance with the appended claims.

CLAIMS

What is claimed:

1. A method for creating a three-dimensional video sequence of a scene, the method comprising:
using at least one processor and memory for:
receiving a two-dimensional video sequence of a scene, the two-dimensional video sequence including a plurality of frames;
selecting a target frame from among the plurality of frames;
selecting a first subset of frames, N, from among the plurality of frames that are associated with the target frame, representative of a targeted stereo displacement of the capture device from the target frame position;
analyzing the first subset of frames to identify two images for use in forming a stereoscopic pair of frames with a predetermined spatial difference;
identifying and classifying static and moving objects between the stereoscopic pair of frames;
extracting depth data of static objects in the stereoscopic pair of frames;
selecting a second subset of frames, n, from among the plurality of frames that are associated with the target frame, representative of a stereo displacement that is substantially smaller than the displacement represented by N;
utilizing the second subset of frames to calculate depth of moving objects;
combining the depth values of static and moving objects based on an absolute depth of static objects and the relative depth of moving objects; and
generating a three-dimensional video frame consisting of the target frame and a depth-generated view corresponding to the target frame based on the depth data.
2. The method of claim 1, further comprising one or more steps of identifying suitable frames, registration, stabilization, color correction, transformation, and depth adjustment.
3. The method of claim 1, further comprising generating one or more additional frames and frame viewpoints using one of existing raster data and depth information.

4. The method of claim 1, further comprising using a micro stereo base technique for generating image representations of close and moving objects of the scene.
5. The method of claim 1, further comprising using a macro stereo base technique for generating image representations of a background and non-moving objects of the scene.
6. The method of claim 1, further comprising using an image capture device for capturing the two-dimensional video sequence.
7. The method of claim 1, further comprising using the steps of claim 1 for generating a plurality of three-dimensional video frames.
8. The method of claim 1, further comprising dividing the captured two-dimensional video sequence into segments divided by utilizing one of a scene change detection and camera pose information.
9. The method of claim 8, further comprising creating a stereoscopic video sequence from each segment.
10. The method of claim 9, further comprising equalizing the depths and other three-dimensional parameters and combining the individual stereoscopic segments to form a single three-dimensional video stream.
11. The method of claim 1, further comprising analyzing captured frames to measure object displacements between two or more frames via motion vectors and identifying and classifying static and moving objects within the current target frame.
12. The method of claim 1, further comprising:
analyzing captured frames; and
identifying a position of key static objects to estimate the position of the camera.

13. The method of claim 1, further comprising measuring the motion vectors of the moving objects and estimating their relative position on the x, y space.
14. The method of claim 1, further comprising:
measuring sizes of moving objects; and
estimating their relative position on the z-space based on the rate of increase or decrease of their sizes.
15. The method of claim 1, further comprising estimating the depth of moving objects by identifying the depth of key points of moving objects relative to the depth of neighboring static objects with known depths and extrapolating based on temporal or structural relationships.
16. The method of claim 1, further comprising estimating the depth of moving objects by determining whether they are moving behind or in front of static objects and utilizing the depth of static objects to estimate the depth of a moving object based on the moving object's trajectory in time.
17. The method of claim 1, further comprising:
segmenting the static portions of the scene into static objects with known positions in three-dimensional space and utilizing prediction techniques to estimate the depth of new information entering into the captured video sequence associated with the same or related static objects.
18. The method of claim 1, further comprising:
measuring sizes of static objects; and
estimating changes in camera focal length and adjusting the depth of the scene based on the relative zoom factor of the camera based on their relative rate of increase or decrease over time.
19. A system for creating a three-dimensional video sequence of a scene, the system comprising:
a memory having stored therein computer program code;
a computer processor that executes the computer program code;
a video generator configured to:

receive a two-dimensional video sequence of a scene, the two-dimensional video sequence including a plurality of frames;

select a target frame from among the plurality of frames;

select a first subset of frames, N, from among the plurality of frames that are associated with the target frame, representative of a targeted stereo displacement of the capture device from the target frame position;

analyze the first subset of frames to identify two images for use in forming a stereoscopic pair of frames with a predetermined spatial difference;

extract depth data of static objects in the stereoscopic pair of frames;

select a second subset of frames, n, from among the plurality of frames that are associated with the target frame, representative of a stereo displacement that is substantially smaller than the displacement represented by N;

utilize the second subset of frames to calculate depth of moving objects;

combine the depth values of static and moving objects based on the absolute depth of static objects and the relative depth of moving objects; and

generate a three-dimensional video frame consisting of the target frame and a depth-generated view corresponding to the target frame based on the depth data.

20. The system of claim 19, wherein the video generator is configured to implement one or more functions of identifying suitable frames, registration, stabilization, color correction, transformation, and depth adjustment.

21. The system of claim 19, wherein the video generator is configured to generate one or more additional frames and frame viewpoints using one of existing raster data and depth information.

22. The system of claim 19, wherein the video generator is configured to use a micro stereo base technique for generating image representations of close and moving objects of the scene.

23. The system of claim 19, wherein the video generator is configured to use a macro stereo base technique for generating image representations of a background and non-moving objects of the scene.

24. The system of claim 19, comprising an image sensor and a lens configured to capture the two-dimensional video sequence.

25. The system of claim 19, wherein the video generator is configured to generate a plurality of three-dimensional video frames using the functions implemented by the video generator recited in claim 19.

26. The system of claim 25, comprising a display configured to display the plurality of three-dimensional video frames in a sequence.

27. A computer program product for creating three-dimensional video sequence, the computer program product comprising:

a computer readable storage medium having computer readable program code embodied therewith, the computer readable program code comprising:

computer readable code configured to receive a two-dimensional video sequence of a scene, the two-dimensional video sequence including a plurality of frames;

computer readable code configured to select a target frame from among the plurality of frames;

computer readable code configured to select a first subset of frames, N , from among the plurality of frames that are associated with the target frame, representative of a targeted stereo displacement of the capture device from the target frame position;

computer readable code configured to analyze the first subset of frames to identify two images for use in forming a stereoscopic pair of frames with a predetermined spatial difference;

computer readable code configured to extract depth data of static objects in the stereoscopic pair of frames;

computer readable code configured to select a second subset of frames, n , from among the plurality of frames that are associated with the target frame, representative of a stereo displacement that is substantially smaller than the displacement represented by N ;

computer readable code configured to utilize the second subset of frames to calculate depth of moving objects;

computer readable code configured to combine the static and moving objects based on the depth data; and

computer readable code configured to generate a three-dimensional video frame corresponding to the target frame based on the depth data.

28. The computer program product of claim 27, wherein the computer readable program code comprises computer readable code to implement one or more steps of identifying suitable frames, registration, stabilization, color correction, transformation, and depth adjustment.

29. The computer program product of claim 27, wherein the computer readable program code comprises computer readable code to generate one or more additional frames and frame viewpoints using one of existing raster data and depth information.

30. The computer program product of claim 27, wherein the computer readable program code comprises computer readable code to use a micro stereo base technique for generating image representations of close and moving objects of the scene.

31. The computer program product of claim 27, wherein the computer readable program code comprises computer readable code to use a macro stereo base technique for generating image representations of a background and non-moving objects of the scene.

32. The computer program product of claim 27, wherein the computer readable program code comprises computer readable code to use an image capture device for capturing the two-dimensional video sequence.

33. The computer program product of claim 27, wherein the computer readable program code comprises computer readable code to generate a plurality of three-dimensional video frames.

34. The computer program product of claim 33, wherein the computer readable program code comprises computer readable code to control a display to display the plurality of three-dimensional

video frames in a sequence.

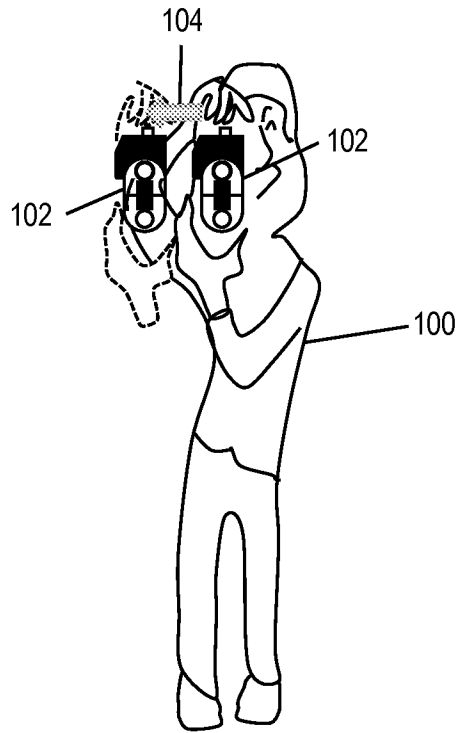

FIG. 1

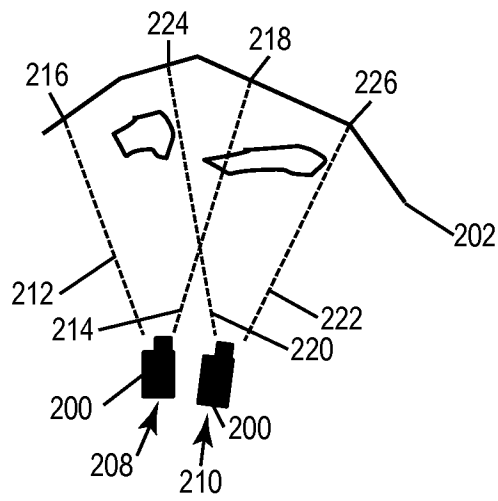

FIG. 2

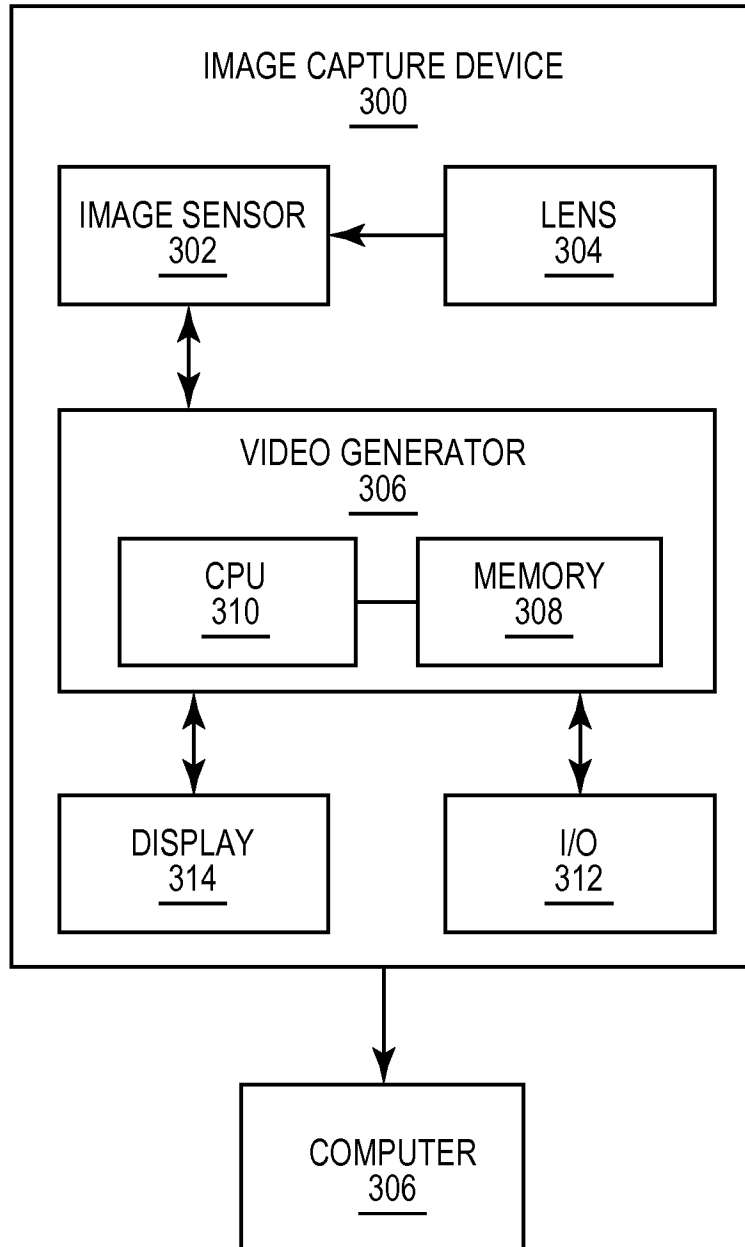

FIG. 3

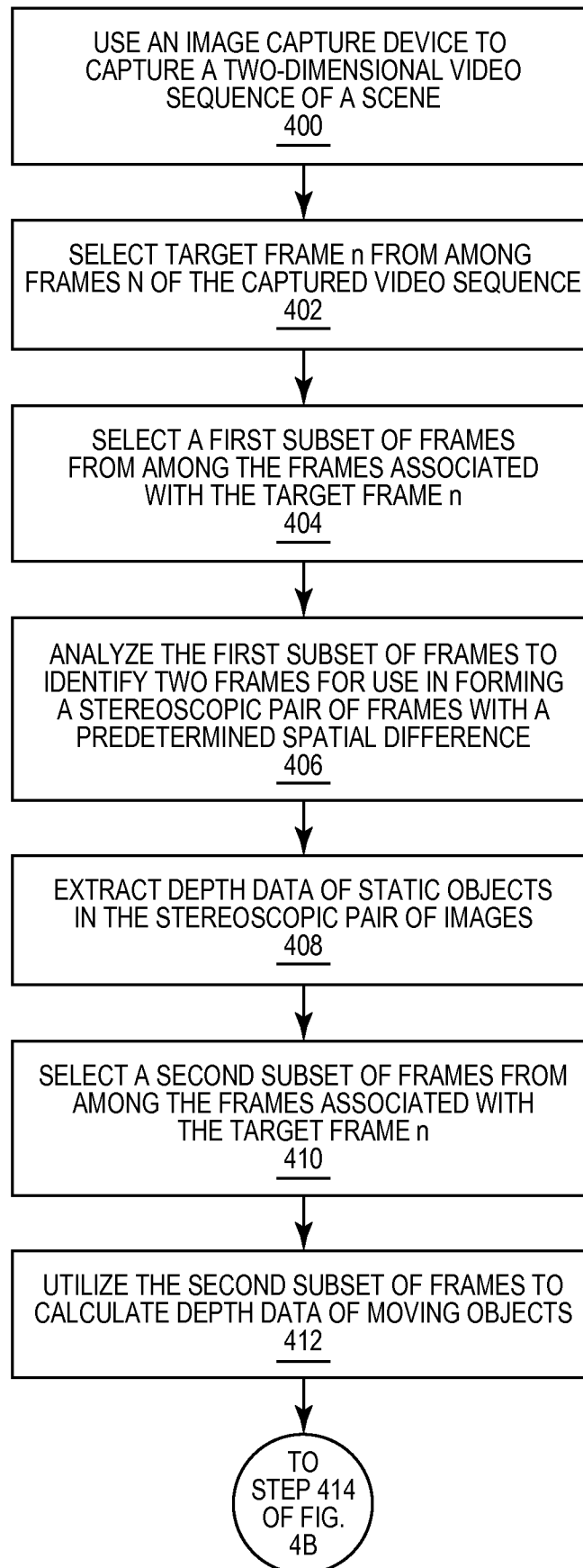

FIG. 4A

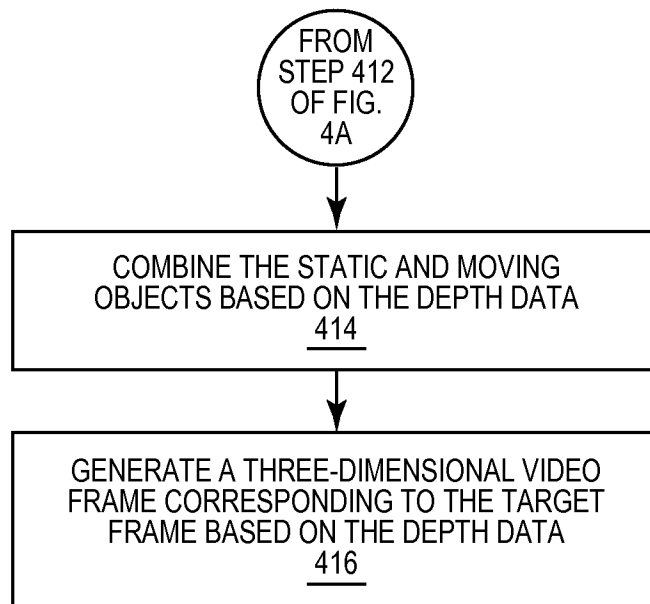

FIG. 4B

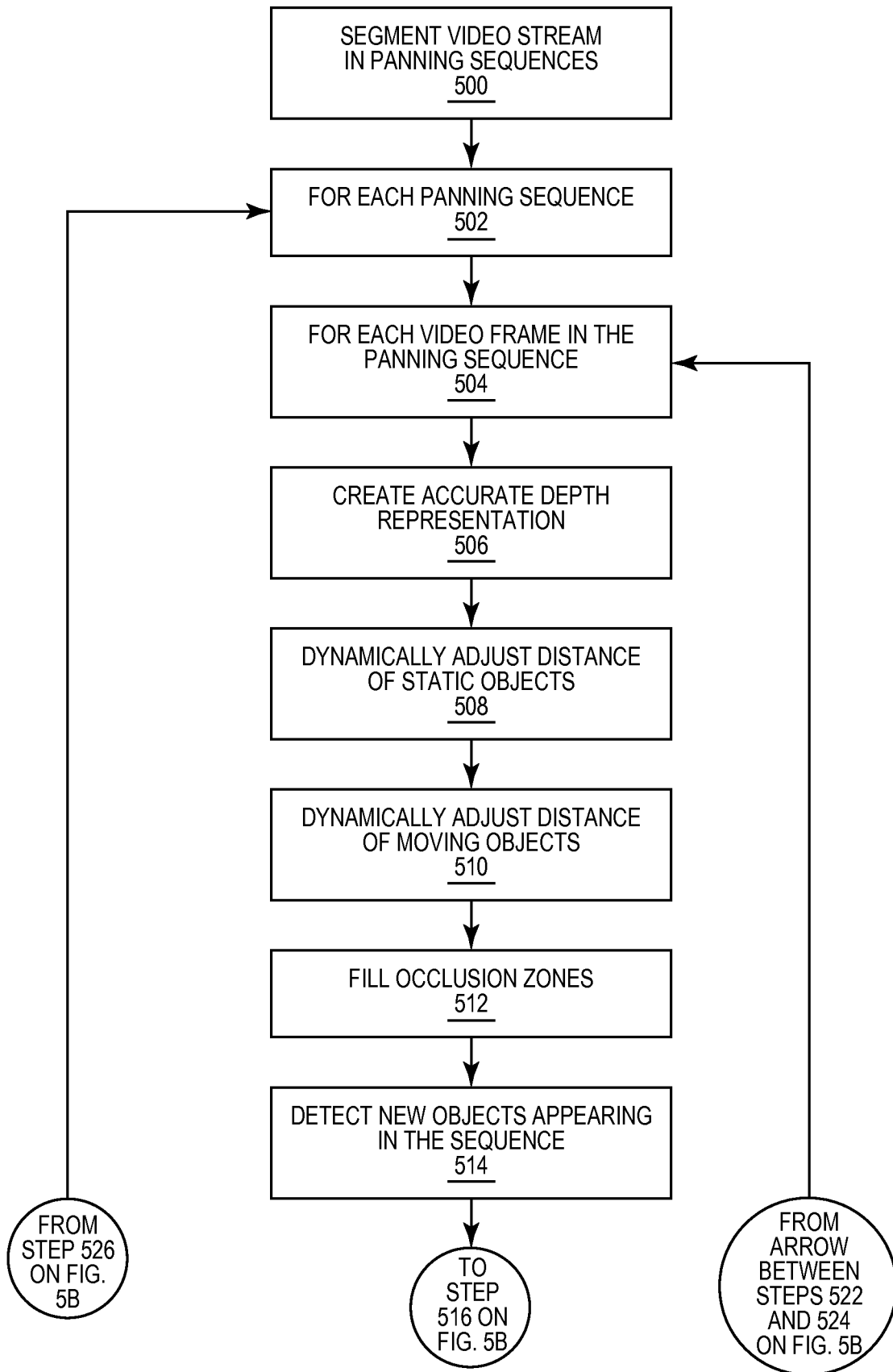

FIG. 5A

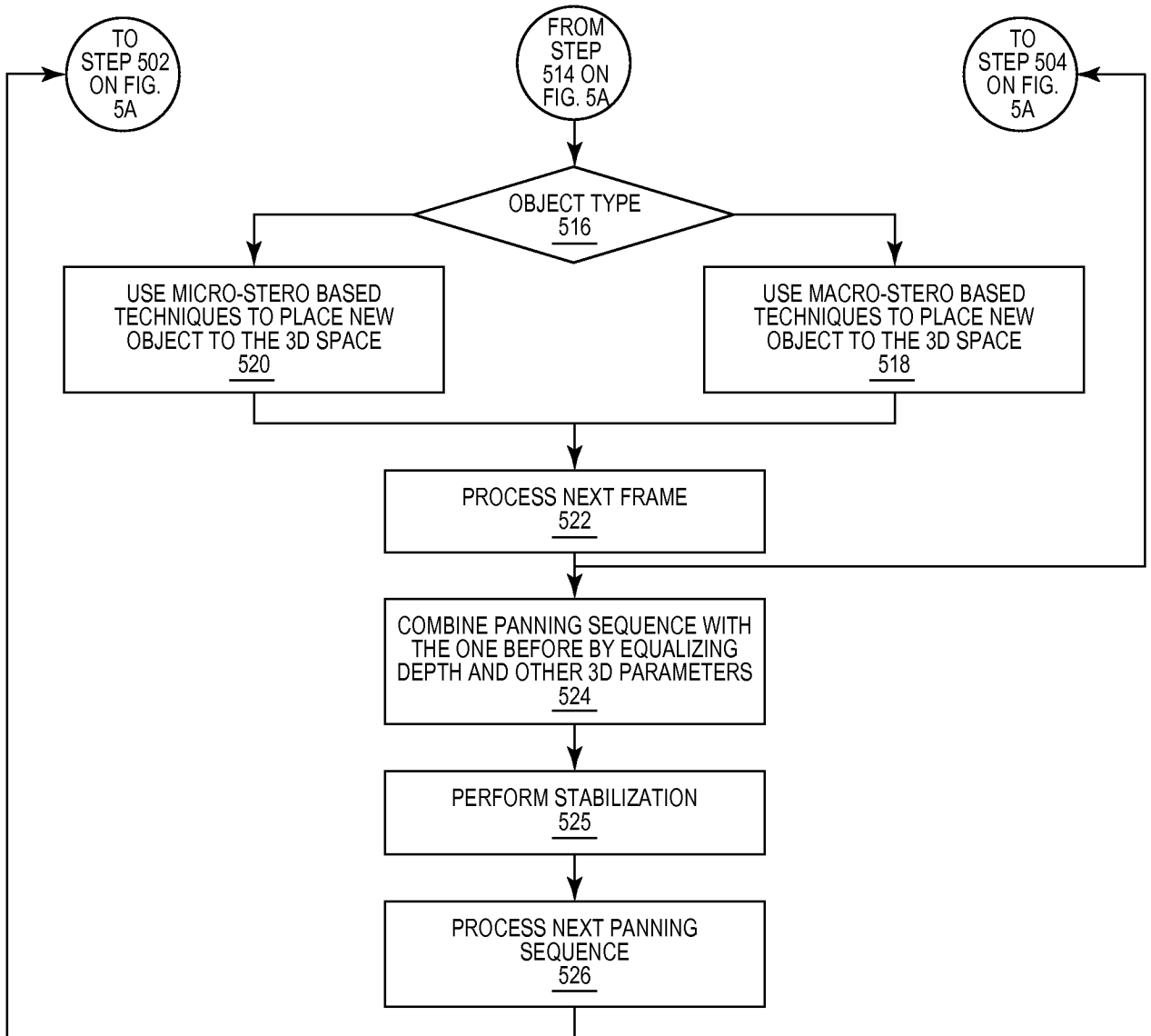

FIG. 5B

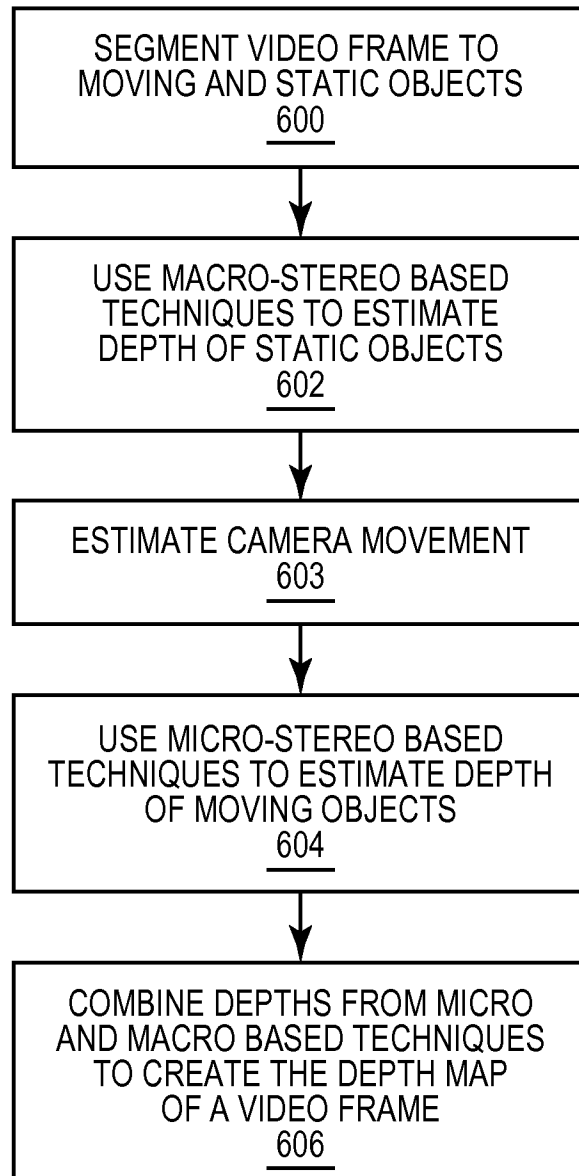

FIG. 6

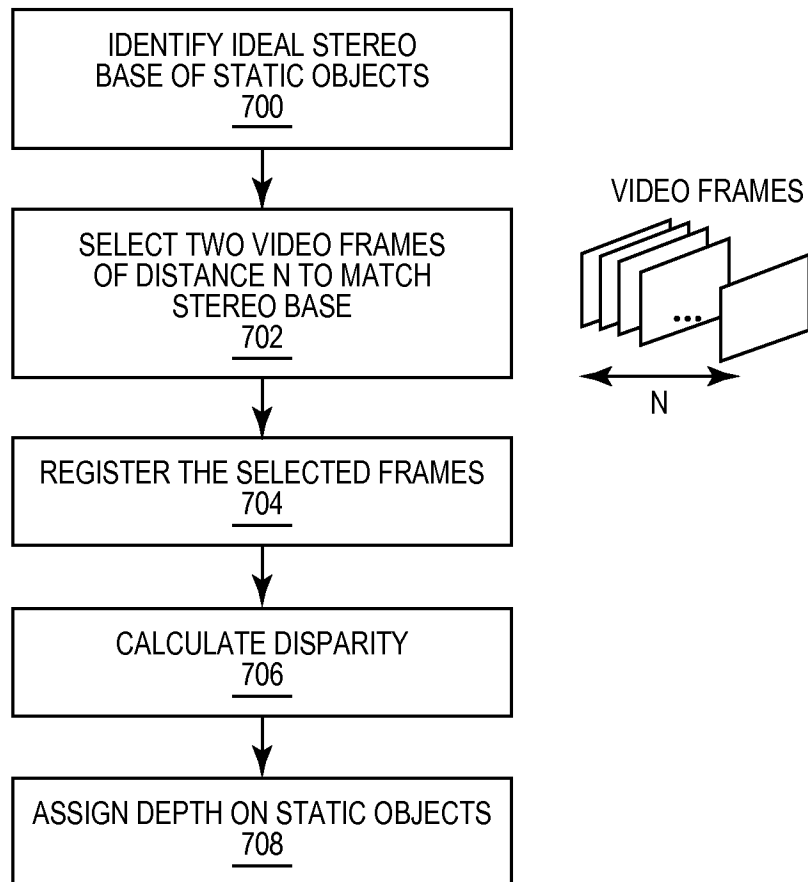

FIG. 7

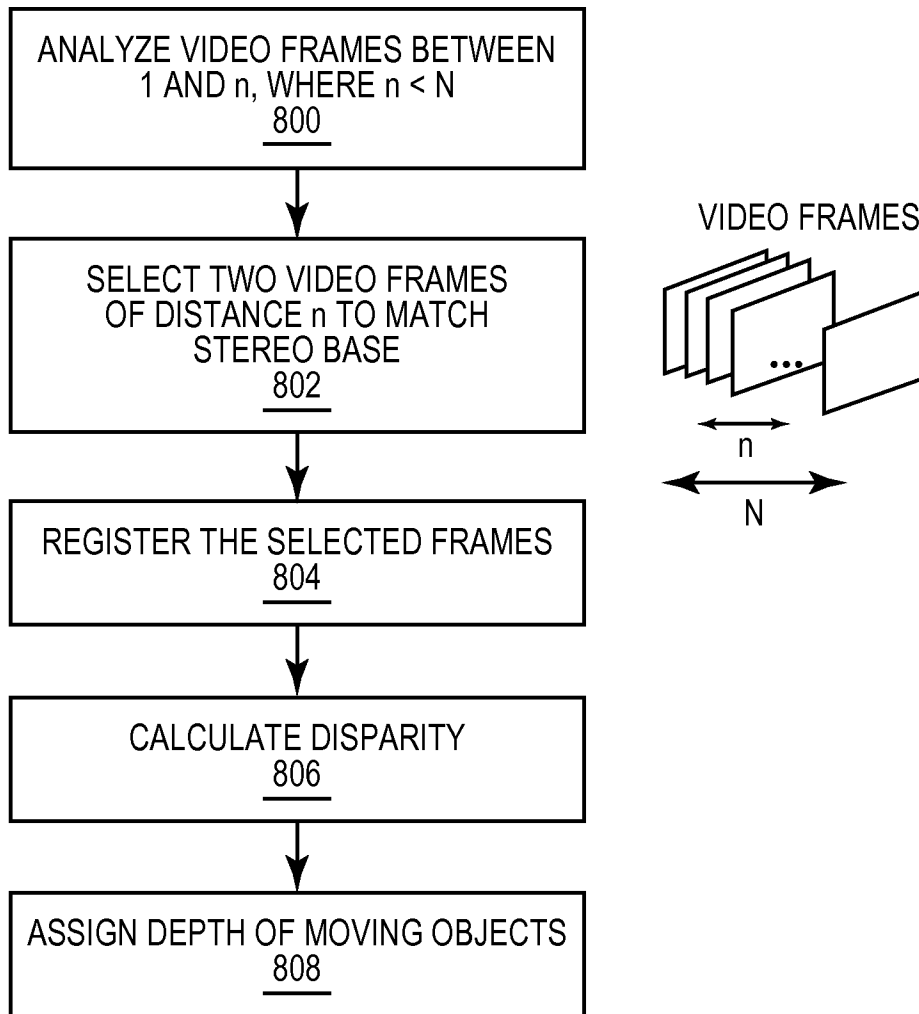

FIG. 8

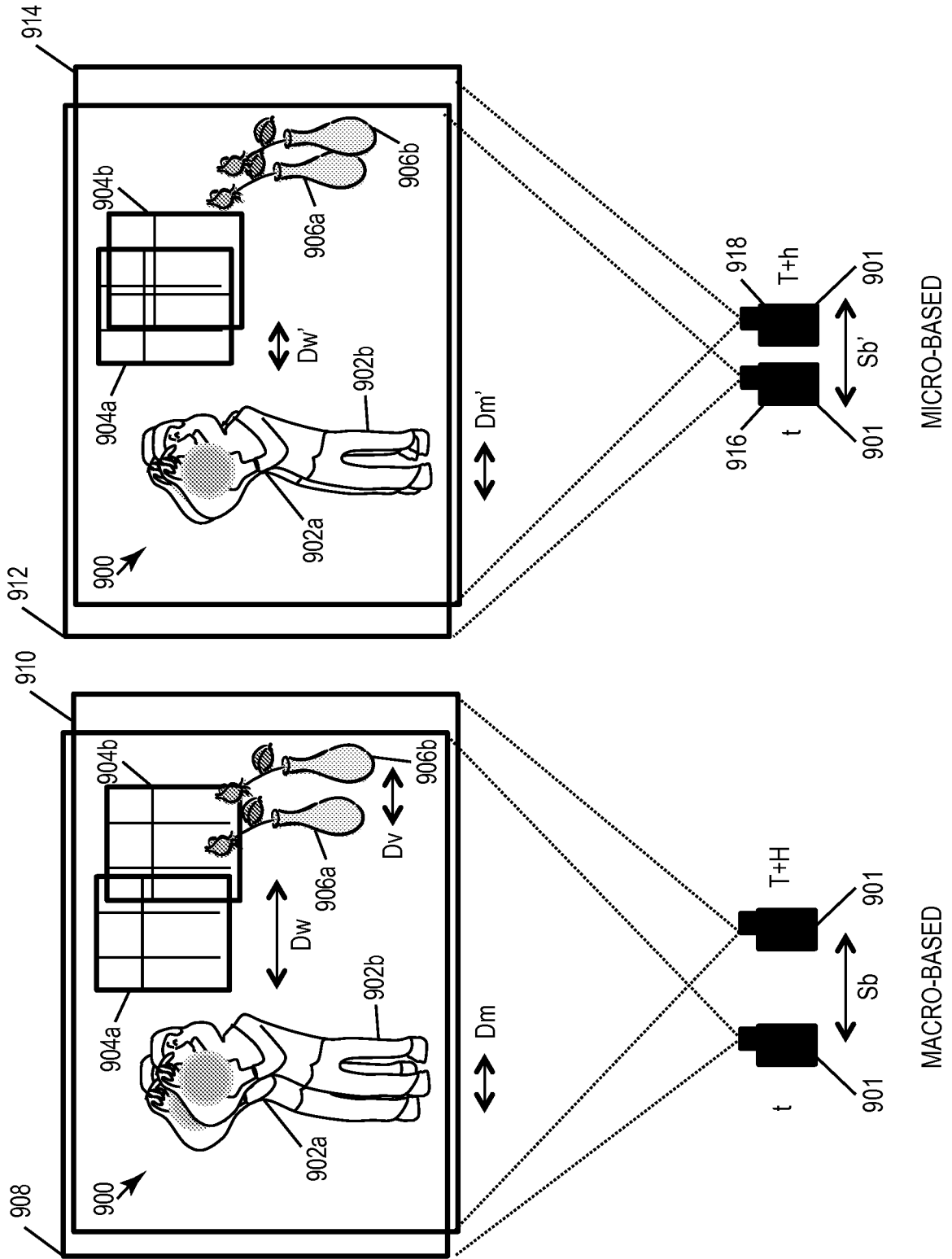

FIG. 9

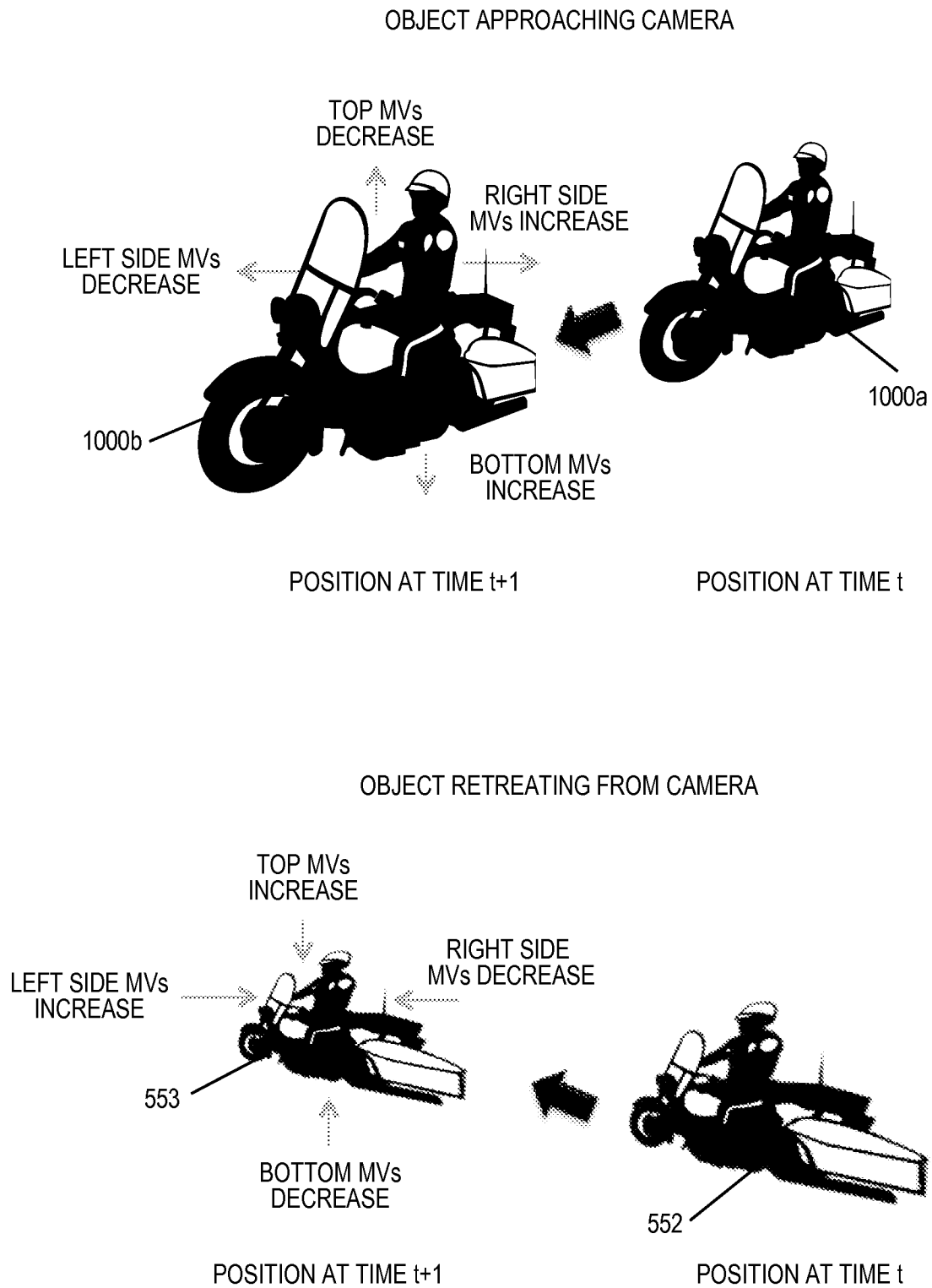

FIG. 10

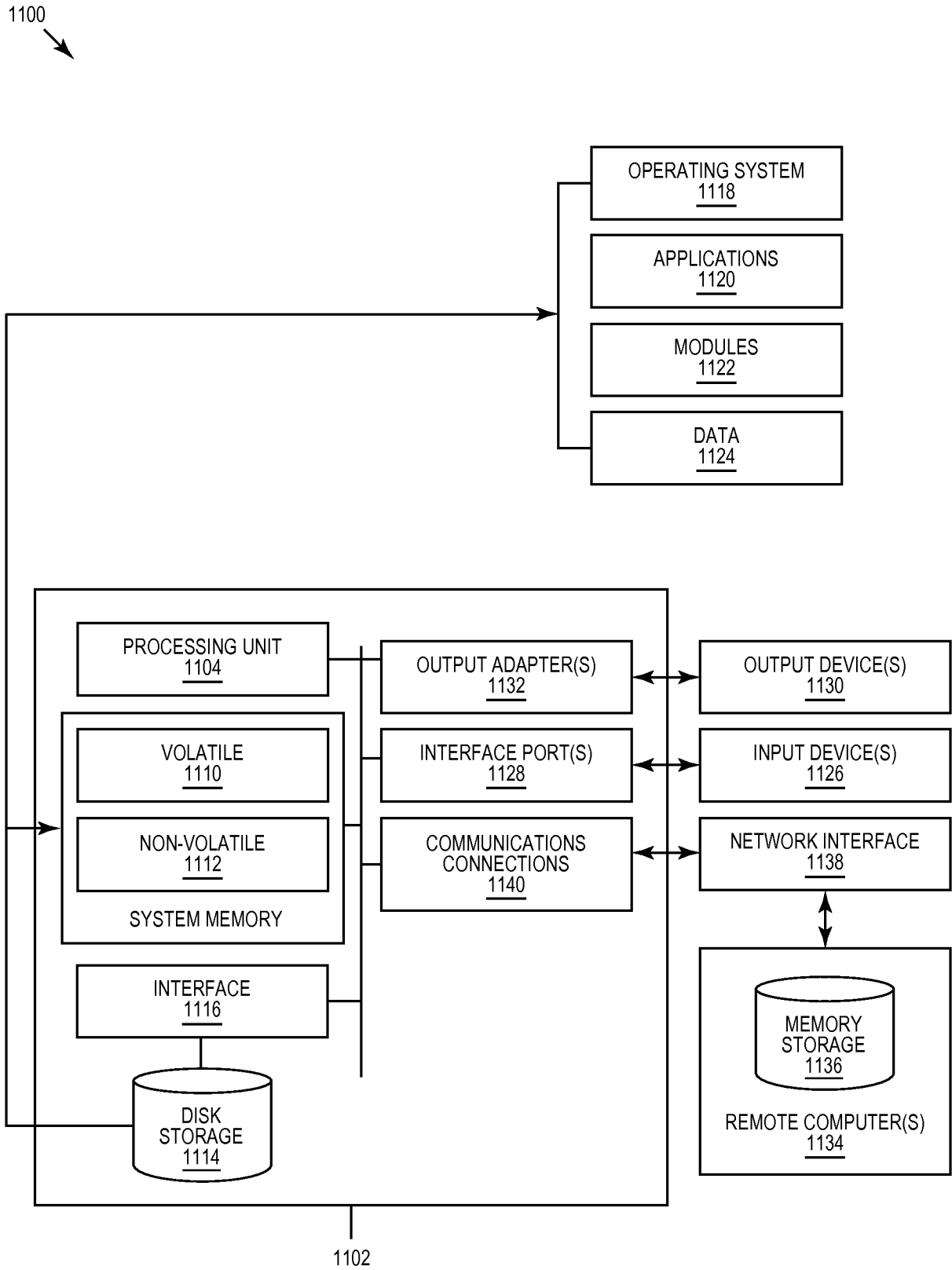

FIG. 11