

(19) World Intellectual Property Organization
International Bureau



(43) International Publication Date
14 May 2010 (14.05.2010)

(10) International Publication Number
WO 2010/054214 A1

- (51) International Patent Classification:
A61B 18/14 (2006.01)
- (21) International Application Number:
PCT/US2009/063576
- (22) International Filing Date:
6 November 2009 (06.11.2009)
- (25) Filing Language: English
- (26) Publication Language: English
- (30) Priority Data:
61/112,097 6 November 2008 (06.11.2008) US
- (71) Applicant (for all designated States except US): **NX-THERA, INC.** [US/US]; 4186 Lexington Avenue N., St. Paul, MN 55126 (US).
- (72) Inventors; and
- (75) Inventors/Applicants (for US only): **HOEY, Michael** [US/US]; 4186 Lexington Avenue N., St. Paul, MN 55126 (US). **SHADDUCK, John, H.** [US/US]; 4186 Lexington Avenue N., St. Paul, MN 55126 (US).
- (74) Agents: **THOMAS, Justin** et al.; Shay Glenn LLP, 2755 Campus Drive, Suite 210, San Mateo, CA 94403 (US).

(81) Designated States (unless otherwise indicated, for every kind of national protection available): AE, AG, AL, AM, AO, AT, AU, AZ, BA, BB, BG, BH, BR, BW, BY, BZ, CA, CH, CL, CN, CO, CR, CU, CZ, DE, DK, DM, DO, DZ, EC, EE, EG, ES, FI, GB, GD, GE, GH, GM, GT, HN, HR, HU, ID, IL, IN, IS, JP, KE, KG, KM, KN, KP, KR, KZ, LA, LC, LK, LR, LS, LT, LU, LY, MA, MD, ME, MG, MK, MN, MW, MX, MY, MZ, NA, NG, NI, NO, NZ, OM, PE, PG, PH, PL, PT, RO, RS, RU, SC, SD, SE, SG, SK, SL, SM, ST, SV, SY, TJ, TM, TN, TR, TT, TZ, UA, UG, US, UZ, VC, VN, ZA, ZM, ZW.

(84) Designated States (unless otherwise indicated, for every kind of regional protection available): ARIPO (BW, GH, GM, KE, LS, MW, MZ, NA, SD, SL, SZ, TZ, UG, ZM, ZW), Eurasian (AM, AZ, BY, KG, KZ, MD, RU, TJ, TM), European (AT, BE, BG, CH, CY, CZ, DE, DK, EE, ES, FI, FR, GB, GR, HR, HU, IE, IS, IT, LT, LU, LV, MC, MK, MT, NL, NO, PL, PT, RO, SE, SI, SK, SM, TR), OAPI (BF, BJ, CF, CG, CI, CM, GA, GN, GQ, GW, ML, MR, NE, SN, TD, TG).

Published:
— with international search report (Art. 21(3))

(54) Title: SYSTEMS AND METHODS FOR TREATMENT OF PROSTATIC TISSUE

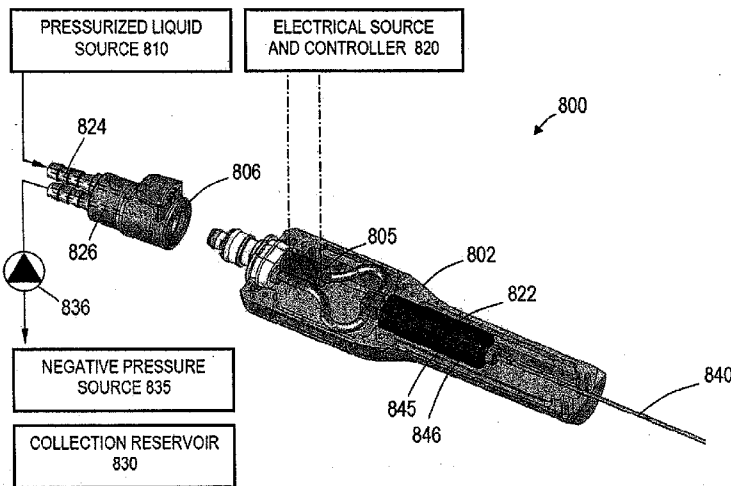

(57) Abstract: A prostate therapy system is provided that may include any of a number of features. One feature of the prostate therapy system is that it can access a prostate lobe transurethrally. Another feature of the prostate therapy system is that it can deliver condensable vapor into the prostate to ablate the prostate tissue. Methods associated with use of the prostate therapy system are also covered.

FIG. 1

WO 2010/054214 A1

SYSTEMS AND METHODS FOR TREATMENT OF PROSTATIC TISSUE

5 CROSS REFERENCE TO RELATED APPLICATIONS

[0001] This application claims the benefit under 35 U.S.C. 119 of U.S. Provisional Patent Application No. 61/112,097, filed November 6, 2008, titled "Systems and Methods for Treatment of Prostatic Tissue." This application is herein incorporated by reference in its entirety.

10

INCORPORATION BY REFERENCE

[0002] All publications and patent applications mentioned in this specification are herein incorporated by reference to the same extent as if each individual publication or patent application was specifically and individually indicated to be incorporated by reference.

15

FIELD OF THE INVENTION

[0003] The present invention relates to an apparatus and a related method for the minimally invasive treatment of prostate tissue.

20

BACKGROUND OF THE INVENTION

[0004] Several systems and methods have been developed or proposed for the treatment of prostate tissue to alleviate BPH symptoms or to treat prostate tissue. For example, tissue ablation methods have been based on RF ablation, microwave ablation, high intensity focused ultrasound (HIFU), cryoablation, radiation, surgery, and brachytherapy. Surgical methods with and without robotic assistance have been developed for removal of diseased prostate tissue.

25

[0005] The apparatus, techniques and methods disclosed herein are adapted to for the treatment of prostate tissue in general and more particularly are focused on treatment of BPH (benign prostatic hyperplasia) and prostate cancer. BPH is a common problem experienced by men over about 50 years old that relates to urinary tract obstruction. Prostatic hyperplasia or enlargement of the prostate gland leads to compression and obstruction of the urethra which results in symptoms such as the need for frequent urination, a decrease in urinary flow, nocturia and discomfort.

30

[0006] Ablation of prostatic tissue with electromagnetic energy is well known and has the advantage of allowing a less invasive approach. For example, high-frequency current in an electrosurgical ablation or prostatic tissue causes cell disruption and cell death. Tissue

35

resorption by the body's wound healing response then can result in a volumetric reduction of tissue that may be causing urinary tract obstruction. One disadvantage of high-frequency current or laser ablation is potential tissue carbonization that results in an increased inflammatory response and far longer healing time following the ablation.

5

SUMMARY OF THE INVENTION

[0007] A method of treating a disorder of a prostate comprises introducing an ablation probe into a lobe of the prostate substantially parallel to a prostatic urethra, and ablating prostate tissue within the lobe without ablating tissue of the prostatic urethra.

10 [0008] Another method of treating a disorder of a prostate adjacent a prostatic urethra comprises delivering condensable vapor into the prostate, and ablating prostate tissue without ablating the prostatic urethra.

[0009] Yet another method of treating a disorder of a prostate comprises introducing an ablation probe transurethrally through a urethral wall into an apex of a lobe of the prostate, and
15 ablating prostate tissue in the prostate lobe.

[0010] In some embodiments, the introducing step can comprise advancing the ablation probe through a urethral wall into an apex of the prostate lobe. In some embodiments, the introducing step comprises advancing the ablation probe at least 15 mm into the prostate lobe. The introducing step can further comprise advancing an introducer into a urethra and advancing the
20 ablation probe through the introducer. In one embodiment, a port of the introducer can be placed against a urethral wall prior to advancing the ablation probe through the introducer. In another embodiment, at least part of the introducer and at least part of the ablation probe have complementary shapes preventing rotation of the ablation probe with respect to the introducer.

[0011] In some embodiments, the ablating step can comprise delivering condensable vapor
25 through the ablation probe into the prostate lobe. The condensable vapor can deliver between 100 and 10,000 Joules to the prostate lobe, or between 20W and 1000W to the prostate lobe, or between 100 cal/gm and 600 cal/gm to the prostate lobe.

[0012] In some embodiments, the delivering step can comprise delivering condensable vapor into the prostate lobe through a plurality of vapor ports in the ablation probe. The vapor ports
30 can be oriented toward the urethra.

[0013] Another embodiment provides a prostate therapy system comprising an ablation probe adapted to be inserted transurethrally into a prostate lobe of an adult male human subject parallel to a prostatic urethra region of the subject, and an energy source operatively connected to the ablation probe to deliver energy to ablate prostate tissue without ablating tissue of the prostatic
35 urethra. The energy source can comprise a condensable vapor source.

[0014] The ablation probe can be further adapted and configured to be advanced through a urethral wall and into an apex of the prostate lobe. In one embodiment, the ablation probe is adapted to be inserted at least 15 mm into the prostate lobe. The system can further comprise an introducer adapted to be inserted into an adult human male urethra, the introducer comprising a distal port, the ablation probe being adapted to be advanced into a prostate lobe through the introducer port.

[0015] In one embodiment, the ablation probe can comprise a plurality of vapor ports.

[0016] In another embodiment, at least part of the introducer probe and at least part of the ablation probe can have complementary shapes preventing rotation of the ablation probe with respect to the introducer.

BRIEF DESCRIPTION OF THE DRAWINGS

[0017] FIG. 1 is a cut-away view of vapor energy delivery system including a handle portion of an instrument with an inductive heating assembly for applying vaporization energy to a fluid flow together with a looped flow system for maintaining a circulating flow of high energy vapor which is releasable on demand to flow through an extension member to interact with tissue.

[0018] FIG. 2 is a schematic view of the inductive heating assembly of FIG. 1.

[0019] FIG. 3 is a schematic view of a patient prostate and a first step of introducing a vapor delivery tool or needle into a proximal aspect of the prostate, wherein the first step includes advancing a distal port to engage the lumen wall at a selected location.

[0020] FIG. 4 is a schematic view of the patient prostate of FIG. 3 with a subsequent step of introducing a sharp-tipped needle or ablation probe into the proximal aspect of the prostate through the distal port member.

[0021] FIG. 5 is a schematic view of a patient prostate and another method of introducing an ablation probe into a proximal aspect of the prostate.

[0022] FIG. 6 is a sectional perspective view of the working end of one embodiment of an ablation probe such as the probe depicted in FIGS. 4-5.

[0023] FIG. 7 is a schematic view of the patient prostate as in FIG. 4 with the delivery of vapor energy to create an ablation region proximate the urethra.

[0024] FIG. 8A is an ablation probe with an electrode for applying additional energy to tissue.

[0025] FIG. 8B is an ablation probe with a bi-polar electrode arrangement.

[0026] FIG. 8C is an ablation probe with an electrode that cooperates with an electrode within the urethra.

DETAILED DESCRIPTION OF THE INVENTION

[0027] A vapor energy generation system is provided that can be configured for introduction into a patient's urethra or prostate, or can be configured to access prostatic tissue trans-rectally or endoscopically. The system is configured to deliver a heated condensable vapor, for example
5 water vapor, to tissue as described in the following co-pending U.S. Patent Applications: United States Patent Application No. 10/681,625, filed October 7, 2003, titled "Medical Instruments and Techniques for Thermally-Mediated Therapies"; No. 11/158,930 filed June 22, 2005, titled "Medical Instruments and Techniques for Treating Pulmonary Disorders"; No. 11/244,329, filed October 5, 2005, titled "Medical Instrument and Method of Use"; and No. 11/329,381, filed
10 January 10, 2006, titled "Medical Instrument and Method of Use".

[0028] The generation and delivery of a collapsible, high energy vapor for various therapeutic procedures is further disclosed in systems with 'remote' vapor generation systems or sources in co-pending Provisional Patent Application Nos. 60/929,632, 61/066,396, 61/068,049, or with vapor generator in a handle or working end, or combination thereof, as described in
15 Provisional Patent Application Nos. 61/068,130, 61/123,384, 61/123,412, 61/126,651, 61/126,612, 61/126,636, 61/126,620.

[0029] FIG. 1 illustrates a vapor energy generation system **800** having a handle **802** comprising an inductive heating system similar to that described in applications 61/123,416, 61/123,417, 61/126,647. In FIG. 1, the handle **802** is coupled by temperature resistant fitting
20 **806** to a fluid source **810** that delivers liquid at a controlled flow rate and pressure. The liquid flow passes through a vapor generating inductive heater **805** coupled to an electrical source and controller **820**. The system and handle is configured for a looped liquid/vapor flow to provide vapor to working end or exit channel **822** to deliver the vapor to a tissue site. The system has inflow channel indicated at **824** and outflow channel at **826** that can communicate with a
25 collection reservoir **830** and/or a negative pressure source **835**. A valve **836**, for example, operated by a footswitch is provided in outflow channel **826** to re-direct vapor into the exit channel **822** and extension member **840**.

[0030] A vapor energy generation system **800** as shown in FIG. 1 can be used for any surgical/medical application, with the extension member **840** comprising a needle, an elongate
30 ablation probe, a flexible catheter, or other similar elongate delivery devices. This system can be used for a catheter for delivering energy for endovascular applications, for treating respiratory tract disorders, for endometrial ablation treatments or for needle ablation treatments. In the embodiment of FIG. 1, an optional secondary heater **845** is shown with a concentric insulator **846**. This secondary heater can add further vaporization energy to vapor that starts to flow
35 through exit channel **822**. The secondary heater can be an inductive heater or a resistive heater

that uses a microporous material to provide a large surface area to apply energy to the vapor to remove any water droplets. This system can provide a vapor that is at least 90% water vapor. The secondary heater is operatively coupled to the electrical source and controller **820** by electrical leads (not shown).

5 **[0031]** FIG. 2 illustrates a vapor generating inductive heater **805** that in one embodiment comprises a ceramic cylinder **850** with a bore **852** therein. The ceramic cylinder **850** can be approximately 1.0" to 1.5" in length and 0.25" in diameter with a 0.10" bore **852**, for example. The bore **852** is packed with a plurality of small diameter hypotubes **855** that are magnetic responsive, such as 316 stainless steel, for example. In one embodiment, the hypotubes **855** are
10 0.016 thin wall tubes. A winding **860** of one to ten layers having an axial length of about 1.0" is provided about the ceramic cylinder **850** for inductive heating of the hypotubes **855** using very high frequency current from an electrical source. In one embodiment the winding **860** can be 26 Ga. Copper wire with a Teflon coating. It has been found that delivering at least 50W, 100W, 200W, 300W, or 400W with suitable flow rates of water can produce very high quality
15 vapor, for example 90% vapor and better.

[0032] In FIG. 2, it can be seen that an inductively heated hypotube **855'** also can be spiral cut to provide flexibility for such an inductive heater to be positioned in a catheter or probe working end. For example, such flexible heatable elements can be carried in the bore of a flexible high temperature resistant polymeric insulative member such to provide a flexible
20 catheter that is configured for endovascular navigation. An insulation layer about an exterior of the inductive heater is not shown. In general, the vapor generating inductive heater **805** can be configured to provide a high quality vapor media with precise parameters in terms of vapor quality, exit vapor pressure from a working end, exit vapor temperature, and maintenance of the parameters within a tight range over a treatment interval. All these parameters can be controlled
25 with a high level of precision to achieve controlled dosimetry, whether the particular treatment calls for very low pressures (e.g., 1-5 psi) or very high pressures (200 psi or greater) over a treatment interval, and whether the treatment interval is in the 1-10 second range or 2 to 5 minute range.

[0033] FIGS. 3-7 illustrate a prostate therapy system, including a vapor source **100**
30 operatively connected to an elongated instrument or introducer **102** with imaging system **104**. The vapor source **100** can be a condensable vapor source, or other appropriate energy sources. The prostate therapy system can be introduced into a patient urethra **105** within prostate **106** and navigated to a predetermined location. The distal end of the instrument and imaging system **104** can be used to identify anatomical landmarks during insertion. The imaging system can be an
35 endoscope or CCD as known in the art. In one embodiment, the introducer **102** can include an

extending member **110** that extends through the urethra, and distal expandable structure such as balloon **112**, which can assist in stabilizing the assembly within the prostate and axially register the assembly relative to anatomic landmarks and structures such as the bladder.

[0034] Referring to FIG. 3, a distal port **115** that can be straight or can have a memory curved configuration is extended from a channel **116** in introducer **102** to engage tissue about the urethra while viewing through the imaging system **104**. The prostate therapy system can include irrigation and aspiration means (not shown) to flow a fluid such as sterile water or saline into and through the urethra **105**. The distal port is extended when the desired location in the urethra is indentified and engaged under slight or moderate pressure of the distal port **115** against the inner wall of the urethra. The distal port may be extended 'slightly' outward of channel **116** or can be extended 5 mm or 10 mm or more from the channel.

[0035] As can be seen in FIG. 4, a vapor delivery needle or ablation probe **120** is extended through the distal port **115** into the prostate **106**. The ablation probe can be operatively connected to the vapor source **100** to deliver energy to ablate prostate tissue. The ablation probe can be adapted to be inserted transurethrally into a prostate lobe of a male subject. In some embodiments, the probe can be adapted to be inserted substantially parallel to the prostatic urethra region of the subject. The probe **120** can have a configuration with at least one curve that allows the working end **122** of the probe **120** having a curved or straight axis to extend substantially parallel to the prostatic urethra **105**, rather than more transverse to the axis of the urethra. In some embodiments, the ablation probe is configured to be advanced through the urethral wall into an apex of the prostate lobe.

[0036] The configuration of the probe working end **122** is adapted for vapor energy delivery and for controlling the geometry of the tissue ablated by the interstitial vapor propagation. In one embodiment, the vapor propagation and region of tissue ablation is elongated and substantially parallel to the urethra. In another embodiment, the vapor propagation and region of tissue ablation extends substantially the length of the urethra through the prostate. In another embodiment, the vapor propagation and region of tissue ablation does not extend to peripheral regions of the prostate capsule except about the urethra. In another embodiment, the vapor propagation and region of tissue ablation does not allow heating of prostate tissue about the prostatic capsule which is adjacent nerves and nerve bundles. The treated tissue geometry is thus optimized for ablation and resorption of prostatic tissue adjacent the urethra without damage to prostate tissue not adjacent the urethra. The procedure described above is repeated to ablate tissue in the opposing prostate lobe. FIG. 5 depicts a method of angling an introducer **102'** to better enable advancement of an ablation probe **120** into the prostate.

[0037] FIG. 6 is a sectional perspective view of the working end of one embodiment of a needle or ablation probe 120. In FIG. 6, the probe 120 and working end 122 have a non-round cross section to prevent rotation relative to the introducer (not shown). The probe 120 can be fabricated of a biocompatible stainless steel or NiTi with a predetermined shape to accomplish to objectives described above. In one embodiment, the working end 122 of the probe carries a plurality of vapor outlets or ports 144 asymmetrically relative to the needle axis and more particularly has vapor outlets oriented to direct vapor flow inwardly toward the urethra. The vapor ports 144 can number from about 2 to 50 and can have mean diameters ranging from about 0.001" to 0.05". In a round probe 120 with a keyed shaft, the hollow needle diameter can range from about 40 ga. to 11 ga., with a similar flow cross section in non-round needles as in FIG. 6. As can be seen in FIG. 6, the probe can be rectangular in section with rounded corners, or alternatively can be oval or round in shape. In a non-round probe, the major axis of the cross-section can be greater than about 1.5x the minor axis of the cross section.

[0038] In FIG. 7, the vapor propagation is depicted with an ablated tissue volume about the urethra indicated at 140. For example, a needle or ablation probe 120 having vapor ports 144 as illustrated in FIG. 6 can allow vapor flowing through the probe to be directed towards the urethra from within the prostatic tissue of a prostatic lobe. In order to achieve the directional propagation of vapor media as in FIG. 7, the probe 120 and its working end are further configured for rotational or angular registration with the distal port 115 and introducer 102 as described above. This aspect can be accomplished by at least a portion of the shaft of probe 120 within the introducer 102 having a 'key' that is slidable within channel 116 to prevent relative rotation between the probe shaft and the introducer. Thus, at least part of the introducer and at least of the ablation probe can have complementary shapes to prevent rotation of the ablation probe with respect to the introducer.

[0039] In general, a method for vapor delivery to ablate prostate tissue introducing a vapor delivery tool or needle into prostate tissue, and applying at least 20W, 50W, 100W, 200W, 400W, or 600W from the tool by means vapor energy release to ablate tissue. In one embodiment, the method applies energy that is provided by a condensable vapor that undergoes a phase change to provide applied energy of at least 100 cal/gm, 250 cal/gm, 300 cal/gm, 350 cal/gm, 400 cal/gm and 450 cal/gm of the vapor.

[0040] In another embodiment shown in FIGS. 8A-8B, the working end 122 of needle or ablation probe 120 can carry a mono-polar electrode 150 or a bi-polar electrode arrangement 152 to further apply energy to tissue. Alternatively, as shown in FIG. 8C, an electrode 154 can be carried the elongate extending member 110 or a hypertonic saline electrode in the urethra can comprise a return electrode to cooperate with an electrode 150.

[0041] In general, a method for treating a disorder of the prostate comprises introducing an ablation probe into a lobe of the prostate, and ablating prostatic tissue within the lobe. The ablation probe can ablate the prostatic tissue by delivering condensable vapor through the probe into the prostate lobe. The ablation probe can ablate prostate tissue within the lobe without
5 ablating tissue of the prostatic urethra.

[0042] To gain access to the prostate, an introducer can be advanced transurethrally into the urethra, and the ablation probe can be advanced through the introducer. In one embodiment, a port of the introducer can be placed against the urethral wall prior to advancing the ablation probe through the introducer. In one embodiment, at least part of the introducer and at least part
10 of the ablation probe can have complementary shapes preventing rotation of the ablation probe with respect to the introducer. In some embodiments, the ablation probe can be introduced into a lobe of the prostate substantially parallel to a prostatic urethra. In some embodiments, the ablation probe can be advanced through a urethral wall into an apex of the prostate lobe. The ablation probe can be advanced at least 15mm into the prostate lobe, for example. In some
15 embodiments, the condensable vapor can be delivered into the prostate lobe through a plurality of vapor ports in the ablation probe. The vapor ports can be oriented towards the urethra, for example.

[0043] These methods can utilize condensable vapor to deliver between 100 and 10,000 Joules to the prostate lobe. In other embodiments, the condensable vapor can deliver between
20 100W and 400W to the prostate lobe, or alternatively, between 20W and 1000W to the prostate lobe. In some embodiments, the condensable vapor can deliver between 250 cal/gm and 450 cal/gm to the prostate lobe, or alternatively, between 100 cal/gm and 600 cal/gm to the prostate lobe. The methods can cause localized ablation of prostate tissue, and more particularly the applied energy from vapor can be localized to ablate prostate tissue adjacent the urethra without
25 damaging prostate tissue that is not adjacent the urethra.

[0044] The handle of an integrated system for prostate treatment with vapor delivery (not shown) can be configured with sliders, levers, grips etc for actuating the (i) extension of a distal port, (ii) the advancement of an ablation probe from the distal port, and (iii) the delivery of vapor for a selected treatment interval. All these systems can be manually actuated, robotic or
30 computer controlled.

[0045] In another embodiment, a method for treating a prostate disorder comprises introducing a thermal energy delivery member into prostate tissue proximate an anterior aspect of the urethra within the prostate and advancing the member distal end to a location proximate a posterior aspect of the urethra within the prostate, and applying energy from the needle to ablate

prostate tissue adjacent the urethra. Again, the energy delivery member can include means to deliver a heated vapor.

[0046] In another embodiment, a method for treating a prostate disorder comprises introducing a vapor delivery tool into prostate tissue proximate an anterior aspect of the urethra within the prostate and advancing the tool distal end at substantially parallel to the urethra within the prostate, and introducing vapor from the tool to ablate prostate tissue adjacent the urethra.

[0047] In another embodiment, a method for treating a prostate disorder comprises introducing a vapor delivery needle into prostate tissue proximate an anterior aspect of the urethra within the prostate and advancing the needle substantially non-transverse relative to an axis of the urethra.

[0048] In another embodiment, a method for treating a prostate disorder comprises introducing a vapor delivery needle into prostate tissue proximate an anterior aspect of the urethra within the prostate and advancing the needle at least 15 mm or at least 20 mm within prostate tissue.

[0049] In another embodiment, a method for treating a prostate disorder comprises introducing a vapor delivery needle into prostate tissue proximate an anterior aspect of the urethra within the prostate and advancing a non-linear shaped needle in a controlled path in the tissue, wherein the needle is keyed relative to an introducer to prevent rotation of the needle.

[0050] In another embodiment, a method for treating a prostate disorder comprises introducing a dull-tipped distal port into a patient urethra, pressing the distal port tip into a targeted location in the wall of the urethra, and advancing a sharp-tipped needle from the distal port and through the wall or the urethra, and delivering energy from the needle to ablate prostate tissue. The needle can be advanced from the distal port by means of a manual actuation or preferably can have a spring-loaded or other robotic actuation of the needle. In one embodiment, a spring-actuated movement of the needle tip is provided to advance the needle tip through the urethra in a first extension distance, and a second extension distance is accomplished by means of manual actuation.

[0051] In another embodiment, the introduction of the needle and the delivery of vapor can be accomplished under any suitable type of imaging. In one method, the steps can be viewed by means of ultrasound or x-ray imaging. In one method, the needle introduction and energy delivery methods can be imaged by ultrasound utilizing a trans-rectal ultrasound system.

[0052] In another embodiment, the system may be used to delivery of fluids for to specific locations in the prostate for medical purposes, such as for general or localized drug delivery, chemotherapy, or injections of other agents that may be activated by vapor or heat.

[0053] As for additional details pertinent to the present invention, materials and manufacturing techniques may be employed as within the level of those with skill in the relevant art. The same may hold true with respect to method-based embodiments in terms of additional acts commonly or logically employed. Also, it is contemplated that any optional feature of the inventive variations described may be set forth and claimed independently, or in combination with any one or more of the features described herein. Likewise, reference to a singular item, includes the possibility that there are plural of the same items present. More specifically, as used herein and in the appended claims, the singular forms "a," "and," "said," and "the" include plural referents unless the context clearly dictates otherwise. It is further noted that the claims may be drafted to exclude any optional element. As such, this statement is intended to serve as antecedent basis for use of such exclusive terminology as "solely," "only" and the like in connection with the recitation of claim elements, or use of a "negative" limitation. Unless defined otherwise herein, all technical and scientific terms used herein have the same meaning as commonly understood by one of ordinary skill in the art to which this invention belongs. The breadth of the present invention is not to be limited by the subject specification, but rather only by the plain meaning of the claim terms employed.

WHAT IS CLAIMED IS:

1. A method of treating a disorder of a prostate comprising:
introducing an ablation probe into a lobe of the prostate substantially parallel to a
5 prostatic urethra; and
ablating prostate tissue within the lobe without ablating tissue of the prostatic urethra.
2. The method of claim 1 wherein the introducing step comprises advancing the ablation
probe through a urethral wall into an apex of the prostate lobe.
10
3. The method of claim 1 wherein the introducing step comprises advancing the ablation
probe at least 15 mm into the prostate lobe.
4. The method of claim 1 wherein the ablating step comprises delivering condensable
15 vapor through the ablation probe into the prostate lobe.
5. The method of claim 4 wherein the condensable vapor delivers between 100 and
10,000 Joules to the prostate lobe.
- 20 6. The method of claim 4 wherein the condensable vapor delivers between 100W and
400W to the prostate lobe.
7. The method of claim 4 wherein the condensable vapor delivers between 250 cal/gm
and 450 cal/gm to the prostate lobe.
25
8. The method of claim 4 wherein the delivering step comprises delivering condensable
vapor into the prostate lobe through a plurality of vapor ports in the ablation probe.
9. The method of claim 8 wherein the introducing step comprises orienting the vapor
30 ports toward the urethra.
10. The method of claim 2 wherein the introducing step comprises advancing an
introducer into a urethra and advancing the ablation probe through the introducer.

11. The method of claim 10 further comprising placing a port of the introducer against a urethral wall prior to advancing the ablation probe through the introducer.

12. The method of claim 10 wherein at least part of the introducer and at least part of the ablation probe have complementary shapes preventing rotation of the ablation probe with respect to the introducer.

13. The method of claim 4 wherein the condensable vapor delivers between 20W and 1000W to the prostate lobe.

14. The method of claim 4 wherein the condensable vapor delivers between 100 cal/gm and 600 cal/gm to the prostate lobe.

15. A prostate therapy system comprising:
an ablation probe adapted to be inserted transurethrally into a prostate lobe of an adult male human subject parallel to a prostatic urethra region of the subject; and
an energy source operatively connected to the ablation probe to deliver energy to ablate prostate tissue without ablating tissue of the prostatic urethra.

16. The system of claim 15 wherein the ablation probe is further adapted and configured to be advanced through a urethral wall and into an apex of the prostate lobe.

17. The system of claim 15 wherein the ablation probe is adapted to be inserted at least 15 mm into the prostate lobe.

18. The system of claim 15 wherein the energy source comprises a condensable vapor source.

19. The system of claim 18 wherein the ablation probe comprises a plurality of vapor ports.

20. The system of claim 15 further comprising an introducer adapted to be inserted into an adult human male urethra, the introducer comprising a distal port, the ablation probe being adapted to be advanced into a prostate lobe through the introducer port.

35

21. The system of claim 20 wherein at least part of the introducer probe and at least part of the ablation probe have complementary shapes preventing rotation of the ablation probe with respect to the introducer.

5 22. A method of treating a disorder of a prostate adjacent a prostatic urethra, the method comprising:

 delivering condensable vapor into the prostate; and
 ablating prostate tissue without ablating the prostatic urethra.

10 23. The method of claim 22 wherein the delivering step comprises advancing a vapor ablation probe transurethrally into the prostate.

 24. The method of claim 23 wherein the advancing step comprises advancing the vapor ablation probe into an apex of a lobe of the prostate.

15 25. The method of claim 22 wherein the condensable vapor delivers between 100 and 10,000 Joules to the prostate.

 26. The method of claim 22 wherein the condensable vapor delivers between 100W and
20 400W to the prostate.

 27. The method of claim 22 wherein the condensable vapor delivers between 250 cal/gm and 450 cal/gm to the prostate.

25 28. The method of claim 22 wherein the condensable vapor delivers between 20W and 100W to the prostate.

 29. The method of claim 22 wherein the condensable vapor delivers between 100 cal/gm and 600 cal/gm to the prostate.

30 30. A method of treating a disorder of a prostate, the method comprising:
 introducing an ablation probe transurethrally through a urethral wall into an apex of a
 lobe of the prostate; and
 ablating prostate tissue in the prostate lobe.

35

31. The method of claim 30 wherein the introducing step comprises advancing the ablation probe at least 15 mm into the prostate lobe.

5 32. The method of claim 30 wherein the ablating step comprises introducing condensable vapor through the ablation probe into the prostate lobe.

33. The method of claim 32 wherein the condensable vapor delivers between 100 and 10,000 Joules to the prostate lobe.

10 34. The method of claim 32 wherein the condensable vapor delivers between 100W and 400W to the prostate lobe.

15 35. The method of claim 32 wherein the condensable vapor delivers between 250 cal/gm and 450 cal/gm to the prostate lobe.

36. The method of claim 32 wherein the introducing step comprises introducing condensable vapor into the prostate lobe through a plurality of vapor ports in the ablation probe.

20 37. The method of claim 36 wherein the introducing step comprises orienting the vapor ports toward the urethra.

38. The method of claim 30 wherein the introducing step comprises advancing an introducer into a urethra and advancing the ablation probe through the introducer.

25 39. The method of claim 38 further comprising placing a port of the introducer against a urethral wall prior to advancing the ablation probe through the introducer.

30 40. The method of claim 38 wherein at least part of the introducer probe and at least part of the ablation probe have complementary shapes preventing rotation of the ablation probe within the introducer.

41. The method of claim 32 wherein the condensable vapor delivers between 20W and 1000W to the prostate lobe.

42. The method of claim 32 wherein the condensable vapor delivers between 100 cal/gm and 600 cal/gm to the prostate lobe.

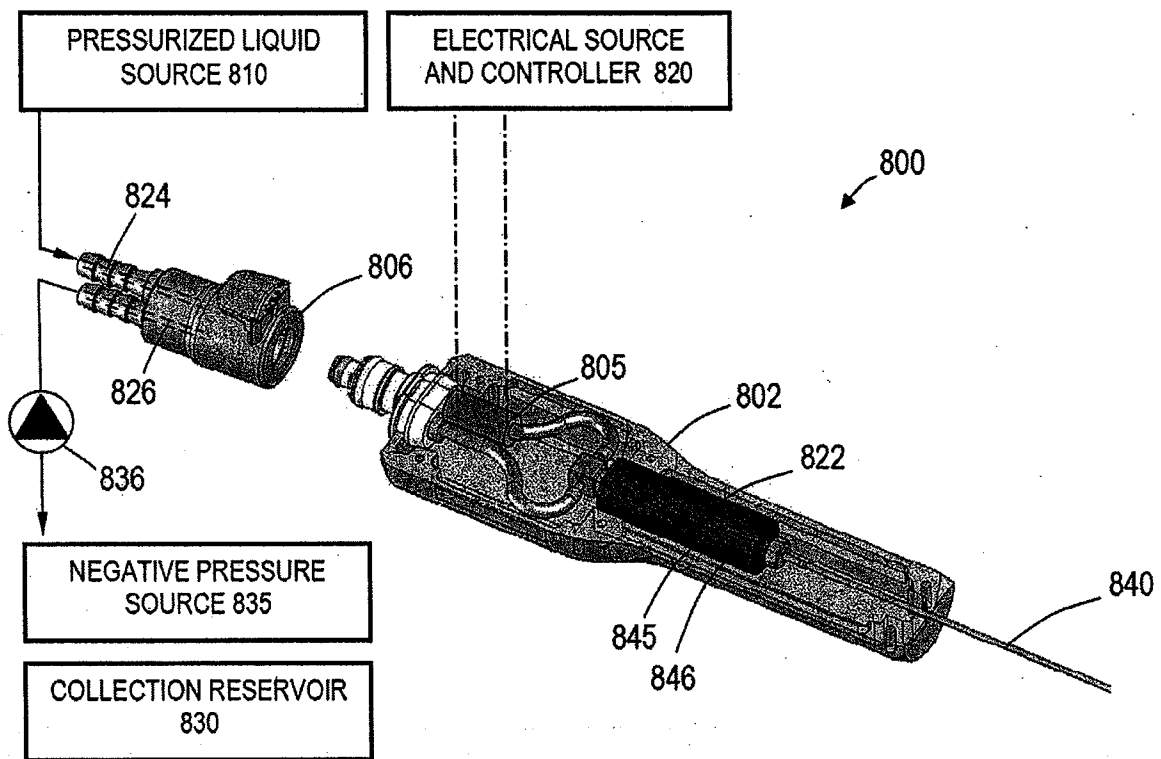

FIG. 1

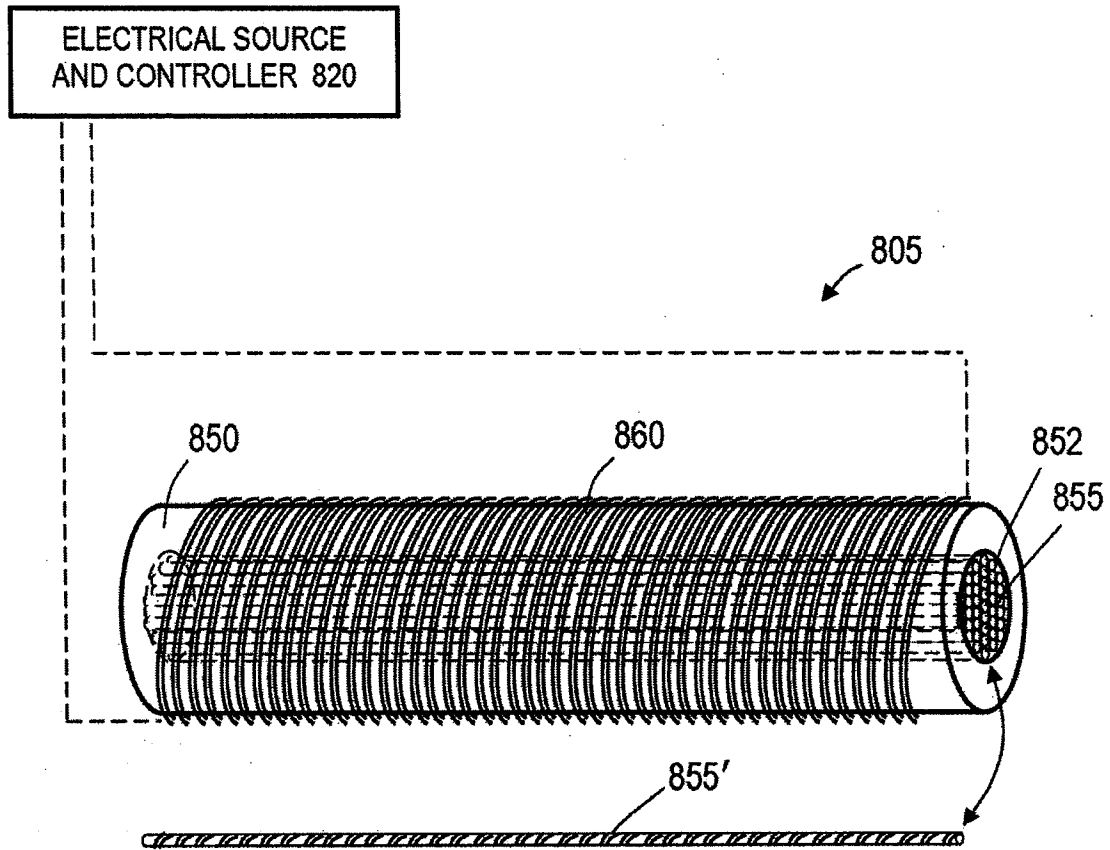

FIG. 2

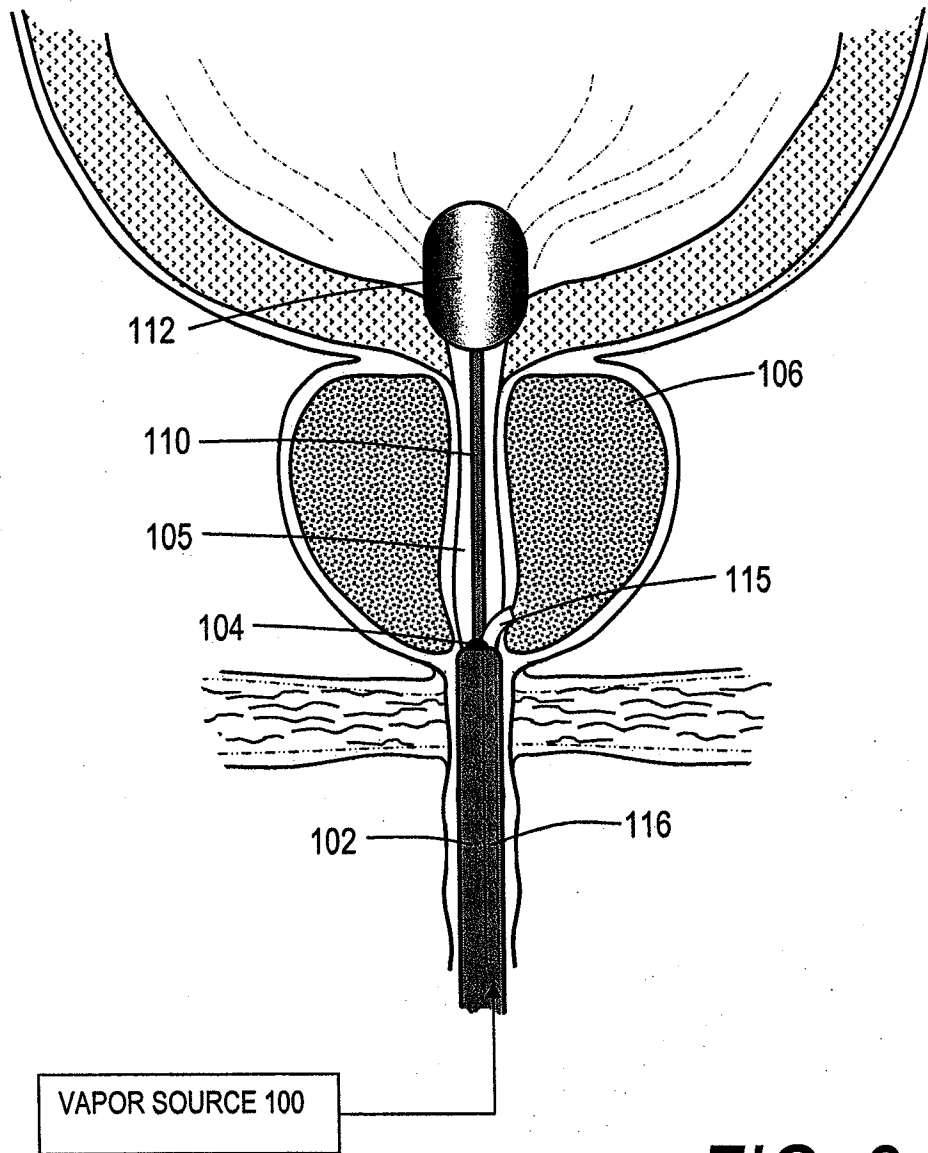

FIG. 3

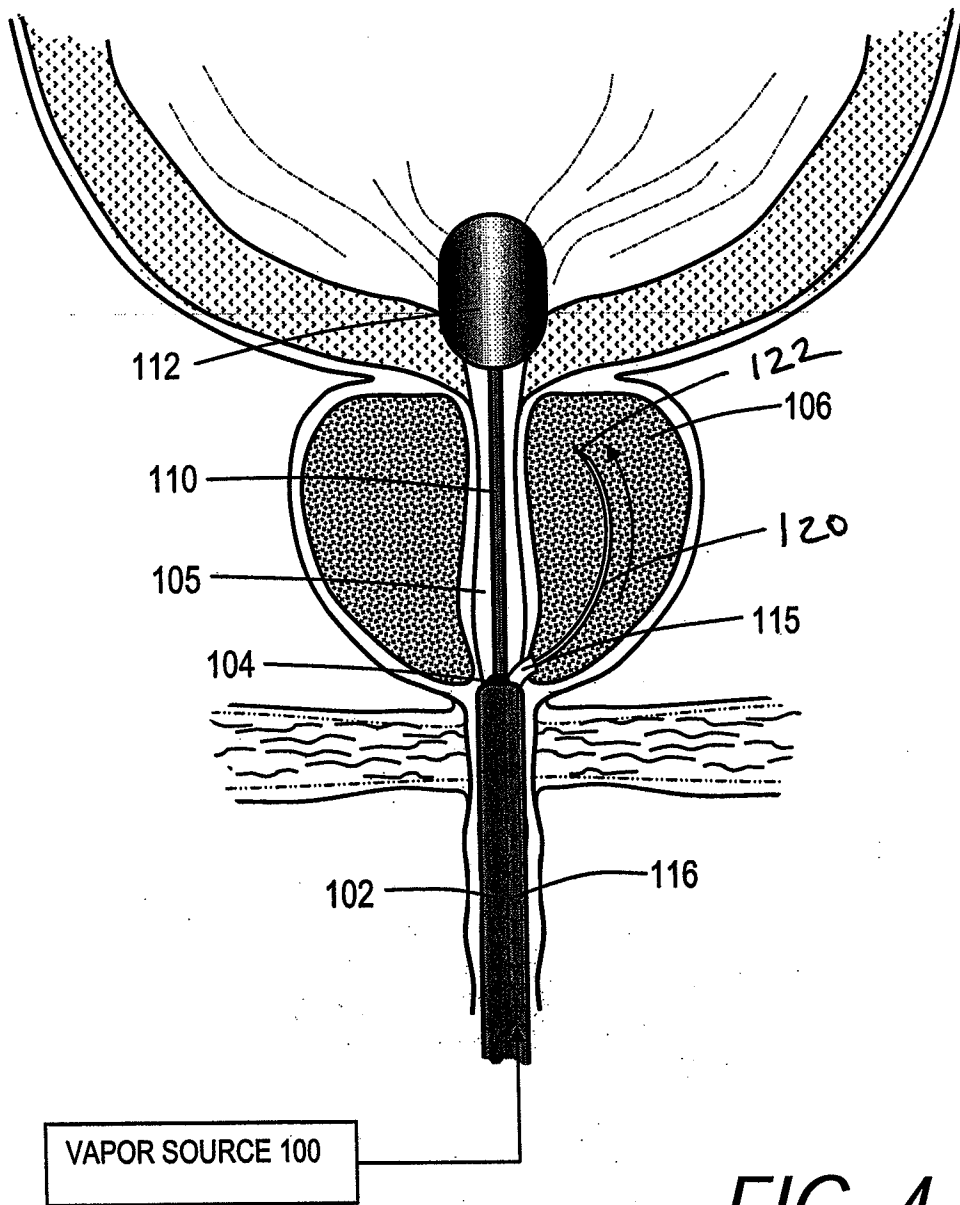

FIG. 4

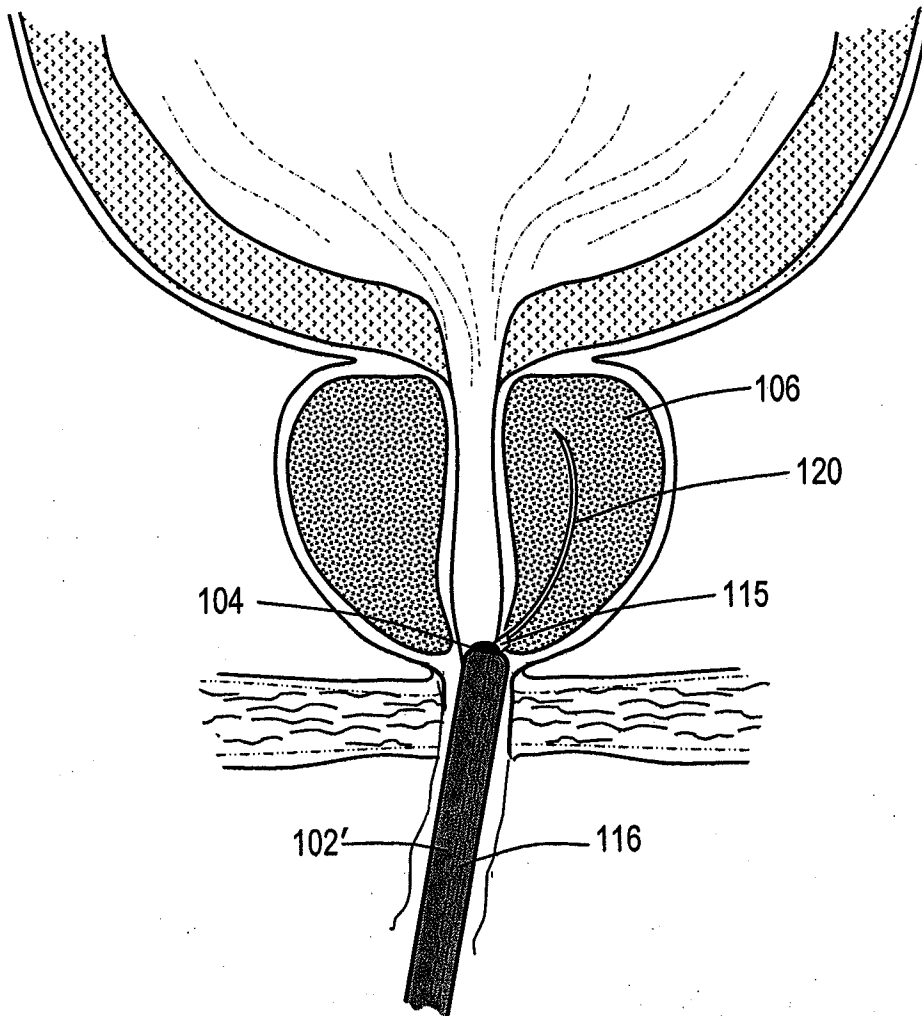

FIG. 5

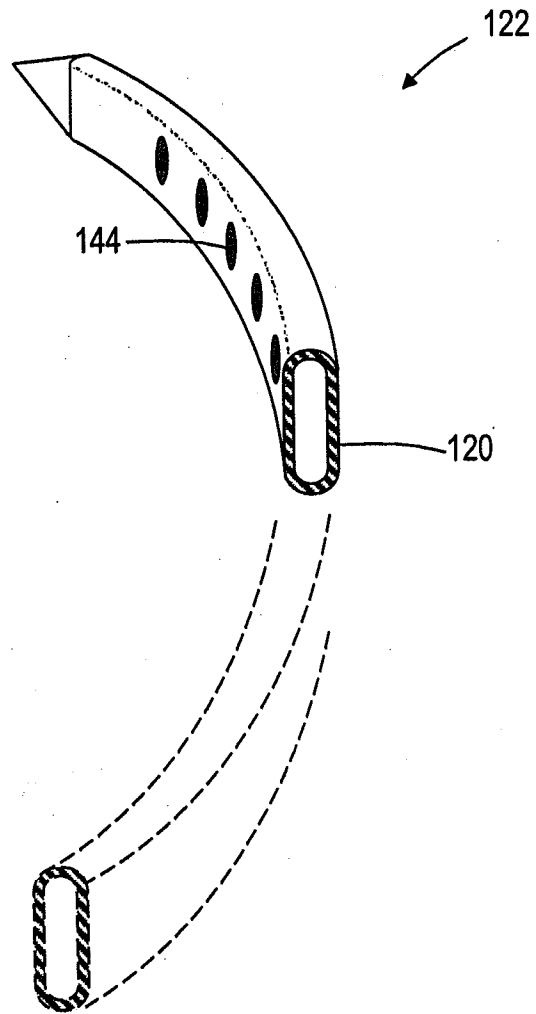

FIG. 6

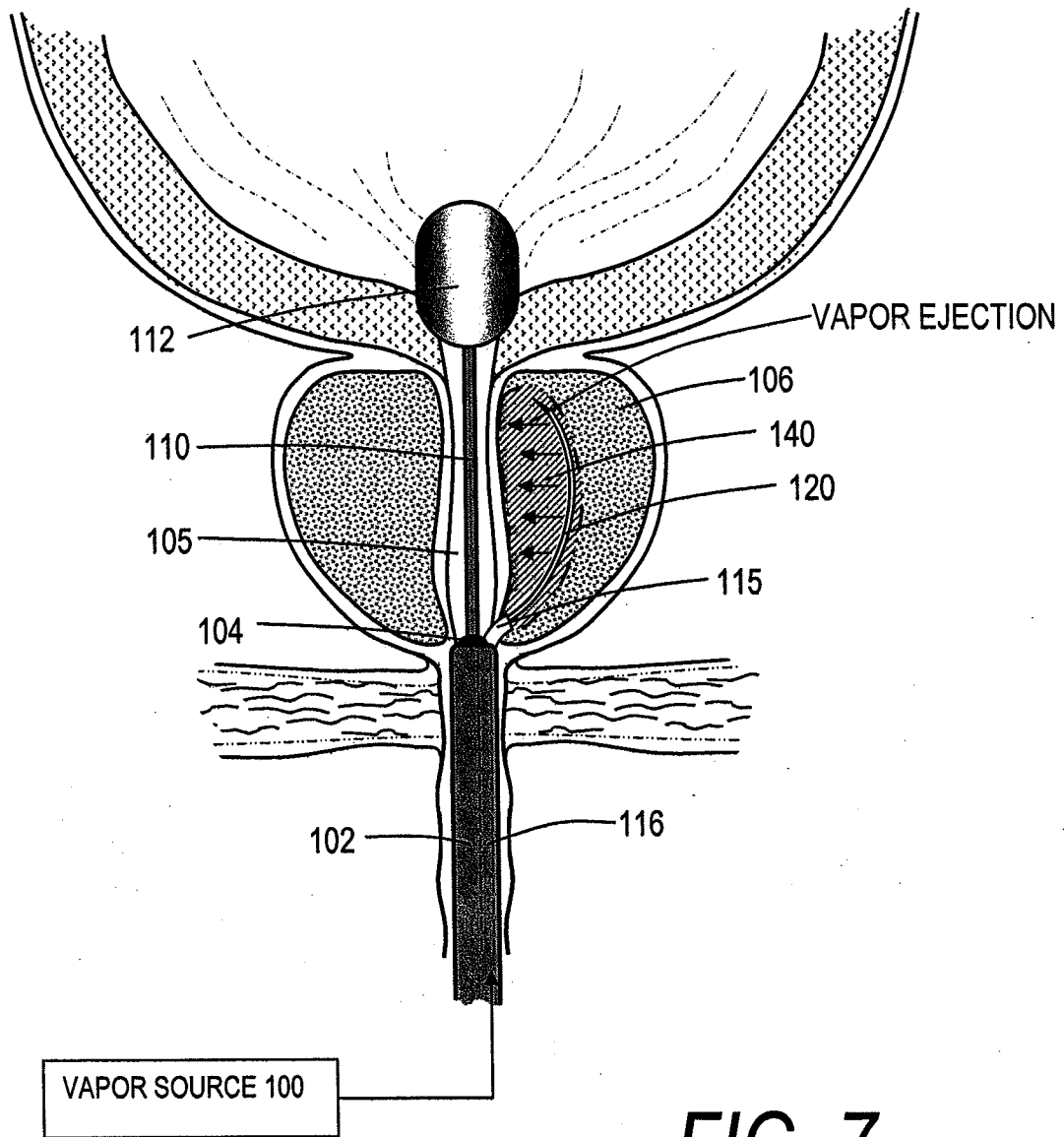

FIG. 7

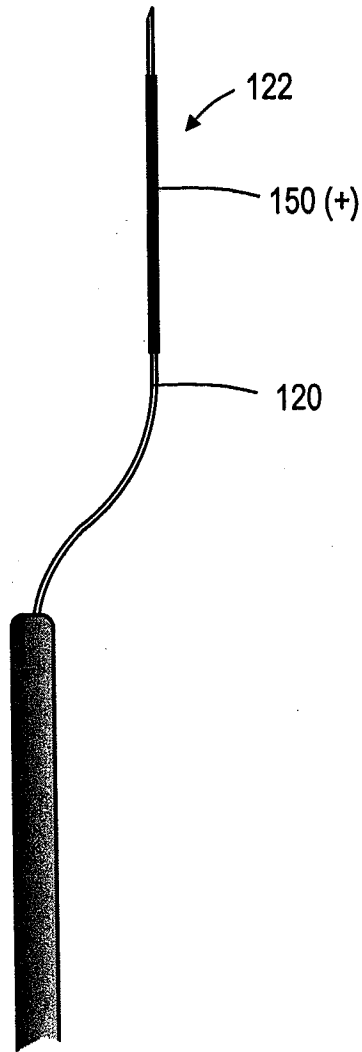

FIG. 8A

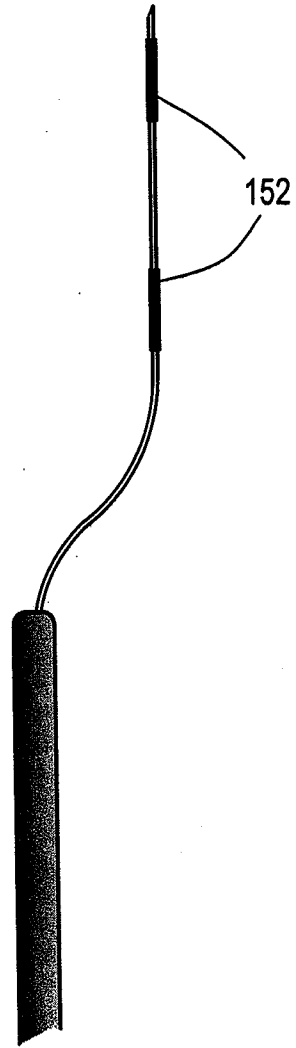

FIG. 8B

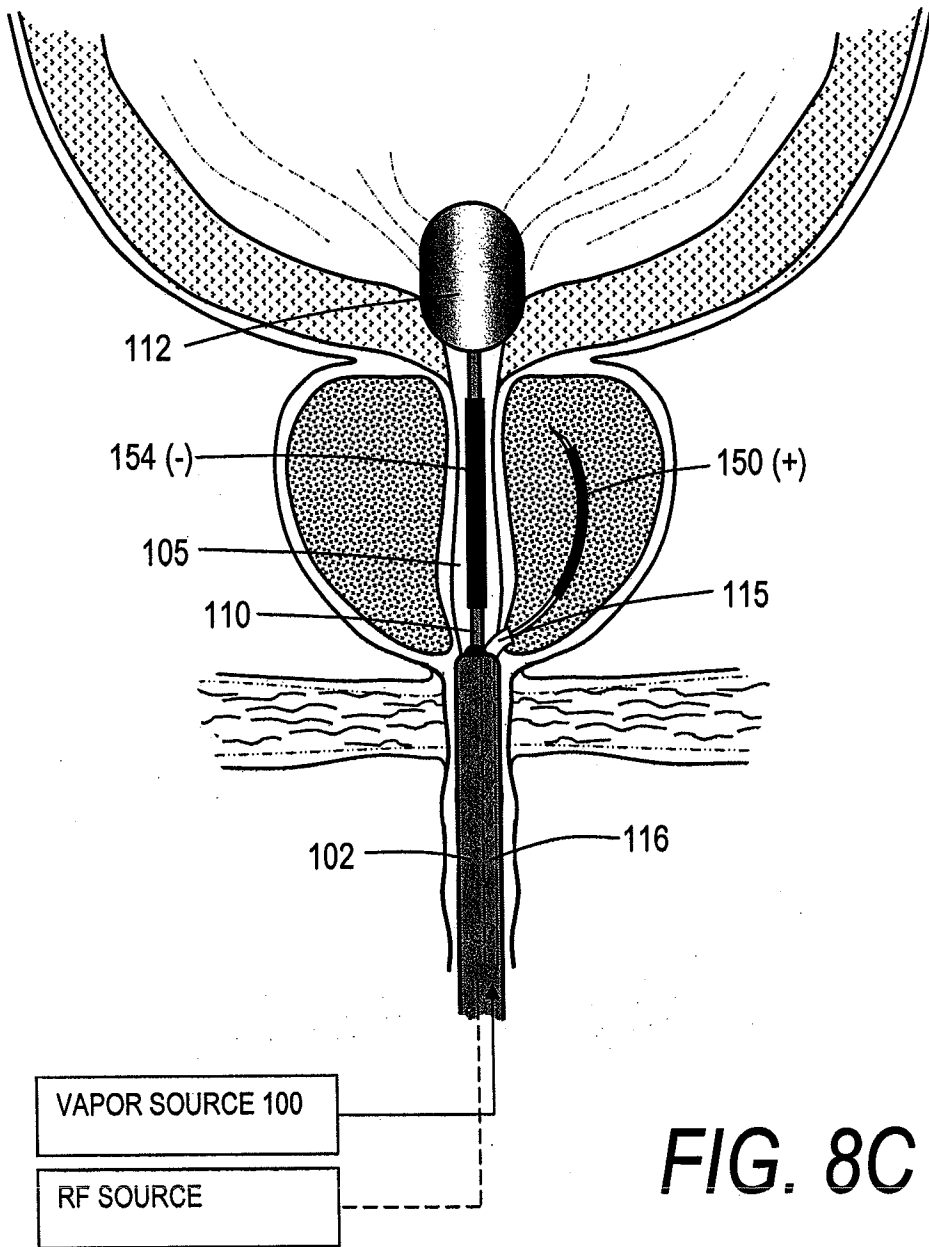

FIG. 8C

INTERNATIONAL SEARCH REPORT

International application No.

PCT/US2009/063576

A. CLASSIFICATION OF SUBJECT MATTER IPC(8) - A61B 18/14 (2009.01) USPC - 607/96 According to International Patent Classification (IPC) or to both national classification and IPC		
B. FIELDS SEARCHED Minimum documentation searched (classification system followed by classification symbols) IPC(8) - A61B 18/00, 18/04, 18/14; A61F 7/00, 7/12; A61M 31/00, 37/00 (2009.01) USPC - 604/19, 23, 27, 514, 517; 606/27, 28, 41; 607/96 Documentation searched other than minimum documentation to the extent that such documents are included in the fields searched Electronic data base consulted during the international search (name of data base and, where practicable, search terms used) PatBase		
C. DOCUMENTS CONSIDERED TO BE RELEVANT		
Category*	Citation of document, with indication, where appropriate, of the relevant passages	Relevant to claim No.
Y	US 2002/0177846 A1 (MULIER et al) 28 November 2002 (28.11.2002) entire document	1-42
Y	WO 01/24715 A1 (RABINER et al) 12 April 2001 (12.04.2001) entire document	1-42
Y	US 2003/0069575 A1 (CHIN et al) 10 April 2003 (10.04.2003) entire document	12, 21, 40
<input type="checkbox"/> Further documents are listed in the continuation of Box C. <input type="checkbox"/>		
* Special categories of cited documents: "A" document defining the general state of the art which is not considered to be of particular relevance "E" earlier application or patent but published on or after the international filing date "L" document which may throw doubts on priority claim(s) or which is cited to establish the publication date of another citation or other special reason (as specified) "O" document referring to an oral disclosure, use, exhibition or other means "P" document published prior to the international filing date but later than the priority date claimed "T" later document published after the international filing date or priority date and not in conflict with the application but cited to understand the principle or theory underlying the invention "X" document of particular relevance; the claimed invention cannot be considered novel or cannot be considered to involve an inventive step when the document is taken alone "Y" document of particular relevance; the claimed invention cannot be considered to involve an inventive step when the document is combined with one or more other such documents, such combination being obvious to a person skilled in the art "&" document member of the same patent family		
Date of the actual completion of the international search 17 December 2009		Date of mailing of the international search report 29 DEC 2009
Name and mailing address of the ISA/US Mail Stop PCT, Attn: ISA/US, Commissioner for Patents P.O. Box 1450, Alexandria, Virginia 22313-1450 Facsimile No. 571-273-3201		Authorized officer: Blaine R. Copenheaver PCT Helpdesk: 571-272-4300 PCT OSP: 571-272-7774