

(19)



(11)

EP 1 917 990 A1

(12)

EUROPEAN PATENT APPLICATION

(43) Date of publication:
07.05.2008 Bulletin 2008/19

(51) Int Cl.:
A61M 5/158 (2006.01) **A61M 39/10** (2006.01)
A61M 25/02 (2006.01)

(21) Application number: **06022674.3**

(22) Date of filing: **31.10.2006**

(84) Designated Contracting States:
AT BE BG CH CY CZ DE DK EE ES FI FR GB GR HU IE IS IT LI LT LU LV MC NL PL PT RO SE SI SK TR
Designated Extension States:
AL BA HR MK RS

(72) Inventors:
• **Tipsmark, Henrik Svogerslev (DK)**
• **Egebjerg Nielsen DK-4100 Ringsted (DK)**

(71) Applicant: **Unomedical A/S**
3460 Birkerød (DK)

(74) Representative: **Nilausen, Kim et al**
Zacco Denmark A/S
Hans Bekkevolds Allé 7
2900 Hellerup (DK)

(54) **Infusion set**

(57) The application relates to an infusion set comprising an infusion part (1) comprising a base part (3) having a main plane, a head part (6) extending from the main plane of the base part and a cannula (12) extending from the base part into the skin of a patient, first fastening means for fastening the infusion part to the skin of a patient, a connector (2) having a plane being parallel to and above the main plane of the base part, and having one or more arms (15), said arms being fastened to the connector at a first end, and being free in a second opposite end, and a tube (14) for connecting the infusion set to a

medical device, guide means (7,16) for positioning the infusion part and the connector in relation to each other, second fastening means (8,17) for fastening the connector to the infusion part, said second fastening means being in the form of projecting connector retention devices (17) positioned on the arms of the connector adapted to engage with retention devices (8) extending from the base part, where the plane of the connector can be tilted to a distance from the base part causing the second to be displaced to a distance from that is larger than the height (h) of the retention devices.

Figure 1

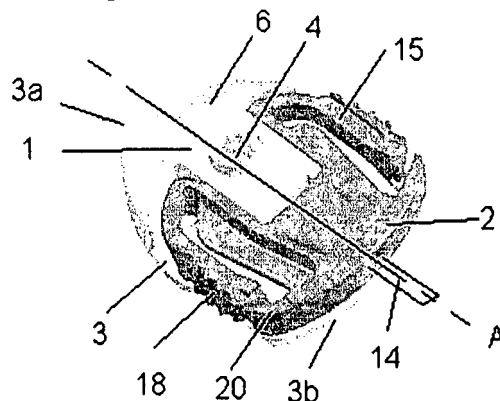

EP 1 917 990 A1

Description

Field of invention

[0001] The invention relates to an infusion set for an intermittent or continuous administration of a therapeutic substance, such as insulin. Further the invention relates to a kit comprising an injector device and an infusion set.

[0002] An infusion set comprises an infusion part with a cannula to penetrate the skin of a person and a connector for connecting the infusion part with a medical device, preferably a medical device such as an insulin pump. An infusion set has in its assembled form a substantially planar rear side and a relatively large width compared to its thickness, thus allowing it to lie flat on the patient's skin and thereby minimizing the discomfort of carrying the infusion set.

[0003] The infusion part is placed stationary on the patient for a longer and not specified period of time while the connector is supposed to be connected and disconnected from time to time. Hereby it is possible for the patient to disconnect from a medical device such as a pump connected to a reservoir of medication, move around and at a later point re-connect to the medical device. Further it is possible to shift between different medical devices e.g. different reservoirs of medication, using the same infusion part and only requiring one penetration of the skin and providing less discomfort to the patient.

[0004] Some people are reluctant or hesitant to pierce their own skin with a medical needle, and thus encounter difficulties in correct needle or cannula placement for proper administration of the medication. Therefore it is possible to use an injector device for the placement of the infusion set into the skin of a patient.

Background of the invention

[0005] WO2005/092410A1 describes an infusion set for intermittent or continuous administration of a therapeutically substance, such as insulin, comprising an infusion part for insertion into a patient and a connector for connecting the infusion part with a medical device through a tube, the connector being axially displaceable relative to the infusion part. The infusion part comprises an adhesive support, a base part with a first set of guiding means and at least two retention devices for locking the connector to the infusion part, a cannula extending from said base part and being in fluid communication with a cavity. The cavity is further adapted to receive a second cannula extending from the connector, which second cannula is in fluid communication with the tube. The connector also comprises at least two arms comprising means corresponding to the retention devices extending from the base part.

[0006] The coupling mechanism between the infusion part and the connector of this infusion set is quite strong when the arms are in a locked position. The risk/chance

of pulling the connector away from the infusion part when positioned on the skin of the patient is negligible for this known infusion set, as the device has front-facing arms and corresponding retention devices.

[0007] When a patient accidentally pulls or overloads the tube extending from the infusion set via the connector by pulling the tube in an upward direction, this results in the connector being tilted relative to the infusion part thereby tightening the engagement between the retention devices on the infusion part and the corresponding retention devices on the two arms of the connector. In this way, the strong coupling mechanism between the connector and the infusion part will result in both the connector and the infusion part not being able to disconnect from each other when the connector or the tube of the connector is being overloaded or pulled in an upward direction but resulting in the whole infusion set being pulled out of the patient's skin. The patient will then have to re-inject a new infusion set with the resulting discomfort.

[0008] Accordingly, it is an object of the invention to provide an infusion set having a coupling mechanism between the infusion part and the connector which coupling mechanism separates the connector from the infusion part when the infusion set is being exposed to overload or accidental pulling of the tube extending from the connector.

[0009] It is another object of the invention to provide an infusion set with a clear view of the insertion site.

30

Summary of the invention

[0010] In a first aspect the present invention relates to an infusion set for intermittent administration of a therapeutically substance through the skin of a patient, comprising an infusion part having a base part with a main plane, a head part extending from the main plane of the base part and having a cannula extending from the base part into the skin of a patient, first fastening means for fastening the infusion part to the skin of a patient, a connector having a plane being parallel to and above the main plane of the base part, and having one or more arms, said arms being fastened to the connector at a first end, and being free in a second opposite end, and a tube for connecting the infusion set to a medical device, guide means for positioning the infusion part and the connector in relation to each other, second fastening means for fastening the connector to the infusion part, the second fastening means being in the form of connector retention devices positioned on the arms of the connector adapted to engage with corresponding retention devices extending from the base part, wherein the plane of the connector can be tilted to a distance from the base plate, causing the second end to be displaced to a distance that is larger than the height of the retention devices, said retention devices being positioned in the second end of the base part, when the connector is positioned via the guide means relative to the infusion part.

[0011] Further, the connector is pivotable at the first end when position in the guide means around an axis, said axis being parallel to the main plane of the base part and perpendicular to a longitudinal axis A of the infusion part.

[0012] It has surprisingly been shown, that the above described infusion set will seem safer to use for the patient than the previously known infusion sets as the infusion part, when the force for disconnecting the connector from the infusion part is less than the force for removing the infusion part from the skin of a patient, will disconnect from the connector, when the connector is being pushed or pulled away in an inclined motion from the infusion part e.g. by an accidental pull of the tube.

[0013] Furthermore, the infusion set can be constructed for an inclined insert, where the cannula can extend from the first end of the base part or head part essentially along a longitudinal axis A or slightly angled in relation to the axis A, in order to provide the patient with an infusion set with an inclined insert in a manner known per se. The infusion set can also be constructed for an insert perpendicular to the skin surface, when mounted into the skin of a patient, where the cannula extends from a lower surface of the base part and perpendicular to said base part.

[0014] When the infusion set is positioned on the skin of a patient, e.g. perpendicular to the skin surface of the patient, the infusion set covers the needle insertion site. In order to get a clear view of the insertion site without removing the infusion part, the head part extending from the base part of the infusion part can be provided with a see-through part. This see-through part can be formed in various ways such as by casting the head part in a transparent polypropylene, by reducing the thickness of the head part or by providing the head part with a magnifying area and the like.

[0015] This ensures a good and clear view of the insertion site whereby it is possible to check the insertion site including that the insertion site is clean and not infected together with the cannula being positioned into the skin of the patient in the right position.

[0016] In a second aspect the invention relates to a kit comprising an injector device and an infusion set according to the invention where the injector device comprises a housing, a plunger slidably received within the housing for movement between an advanced position and a retracted position, the plunger having substantially non-detachably secured thereto an insertion needle for receiving and supporting the cannula of the subcutaneous infusion set in a position with the cannula, where the insertion needle is removable from the cannula while maintaining a transcutaneous placement of the cannula, a drive for urging the plunger from the retracted position toward the advanced position to transcutaneously place said cannula of the subcutaneous infusion set received on the insertion needle.

[0017] The above mentioned kit is designed to place the cannula of the infusion set with the insertion needle

extending therethrough to ensure proper needle placement with minimal patient discomfort. The injector device may also allow placement of the insertion needle through the skin at a selected insertion angle. After priming and placement of the infusion set the injector device is removed and delivery of medication is initiated. The kit comprising the injector device and the infusion set is normally provided to the patient as a sterile sealed single use assembly.

Brief description of the drawings

[0018] In the following the invention will be described in further details with reference to the accompanying drawings.

Figure 1 shows an embodiment of an infusion set where the infusion part and the connector are unified. Figure 2 shows an end view of the same embodiment of an infusion set shown in figure 1.

Figure 3 shows a side view of the same embodiment of an infusion set shown in figure 1.

Figure 4 shows a top view of the same embodiment of an infusion set shown in figure 1.

Figure 5 shows an embodiment of the infusion set where the infusion part and the connector are separated.

Figure 6 shows a side view of the same embodiment of an infusion set shown in figure 5.

Figure 7 shows a top view of the same embodiment of an infusion set shown in figure 5.

Figure 8 shows different shapes of retention devices on the base part.

Figure 8a shows different shapes of connector retention devices on the connector.

Figure 9 shows an embodiment of the injector device for use with the infusion set according to the invention.

Detailed description

[0019] The invention is explained more in detail with reference to the drawings showing an embodiment of the invention.

Infusion set

[0020] Figure 1-7 illustrates an embodiment of an infusion set for intermittent administration of a therapeutically substance through the skin of a patient, where the infusion set comprises an infusion part 1 and a connector 2 for connecting the infusion part 1 with a medical device (not shown) through a tube 14 extending through an opening 19 in the connector 2, as can be seen in figure 2. The connector 2 and the infusion part 1 is having a longitudinal axis A, said connector 2 being axially displaceable along said longitudinal axis A relative to the infusion part 1.

Infusion part

[0021] As can most clearly be seen in figures 5-7, the infusion part 1 comprises a base part 3 with a main plane being essentially parallel to the skin of the patient, when the infusion set is attached to a patient, said base part having a first surface 10 and a second surface 11, the second surface 11 being closest to the skin of a patient and being provided with a first fastening means for fastening the infusion part 1 to the skin of a patient and a head part 6 extending from the first surface, i.e. the main plane, of the base part 3, said head part 6 having a cannula 12 extending from the base part 3 into the skin of a patient. In this embodiment, as shown in figures 5-7, the cannula 12 is extending from the second surface 11 of the base part thereby penetrating the first fastening means. Alternatively the cannula 12 can extend from the head part or the base part 3 of the infusion part 1 essentially along the axis A for an inclined insertion of the cannula 12. Furthermore, the infusion part comprises guide means 7 for positioning the infusion part 1 and the connector 2 in relation to each other these guide means 7 of the infusion part 1 being positioned on the head part 6. As can be seen in figures 1, 3 and 5, the base part 3 has a first end 3a and an opposite second end 3b, the first end 3a being the end provided with the head part 6 and the second end 3b being positioned opposite the first end 3a. The base part 3 can be divided into three parts, the first part incorporating the first end 3b and normally being covered with the head part 6, the middle part normally being provided with a needle insertion opening 4 and the last third incorporating the second opposing end 3b normally being provided with retention devices 8. As shown in figure 4, 5, and 7, the base part 3 is further provided with openings 9, in this case two openings 9, placed between the head part 6 and the retention devices 8. In this embodiment these two openings 9 are related to manufacturing purposes.

First fastening means

[0022] In one embodiment, as illustrated in figure 9, the first fastening means could be in the form of a mounting pad 21 for attaching the infusion part 1 to the skin of a patient comprises an adhesive layer (not shown) and a removable release liner 22, which covers the adhesive layer. In general the adhesive layer is a skin friendly adhesive known per se. The mounting pad may be a dressing, a plaster, an adhesive pad or the like and may be configured in various shapes such as circular, oval, triangular, rectangular etc.

Connector

[0023] As can most clearly be seen in figures 5-7, the connector 2 has a plane being parallel to and above the main plane of the base part 3 when assembled with the infusion part 1. In this embodiment as clearly illustrated

in figure 1, 4, 5 and 7, the connector is provided with two arms 15, which arms are fastened to the connector 2 at a first end 2a, and unfastened and free in a second opposite end 2b, so that the arms 15 can move laterally at the second end 2b. The second end 2b of the connector 2 corresponds to the second end 3b of the base part 3, when the infusion part 1 and the connector 2 are positioned and assembled relative to each other. By providing the connector with two arms 15 it is easier to get a good grip and a better control over the connector 2, when the connector 2 is to be disconnected from the infusion part 1 intended.

[0024] As can be seen in e.g. figure 5-7 the connector 2 is further provided with a protecting part 20 for protection of the free second end 2b of the arms 15, the arms 15 being more flexible at the free second end 2b, and therefore more sensitive to contact at the free second end 2b, in order not to release or disconnect the connector 2 from the infusion part 1 unintended by accident. As mentioned above, the connector comprises the tube 14 positioned in the second end 2b for connecting the infusion set to a medical device. Furthermore, the connector comprises guide means 16 for positioning the infusion part 1 and the connector 2 in relation to each other. The connector 2 can be symmetrically formed around a connector main plane and around the plane perpendicular to the main plane and parallel to the main axis, which allows the connector 2 to match with the base part 3 in two ways.

Flow path

[0025] As can be seen in figures 1-7 the head part 6 of the infusion part 1 is further provided with an insertion needle opening 4 for receiving an insertion needle for insertion of the infusion device, and a connector opening 5 for receiving a second cannula 13, which second cannula 13 is extending from the connector 2 along the longitudinal axis A. This cannula 13 is in fluid connection with the tube 14 extending from the opening 19 in the connector 2, which tube 14 provides the connection to a medical device such as an insulin pump (not shown). In the alternative, as the insertion needle opening 4 is provided for the insertion of a soft cannula 12, the head part 6 need not be provided with an insertion needle opening 4 if the cannula 12 is made of metal. The head part 6 is provided with a cavity (not shown), which cavity is adapted for receiving both the cannula 12 and the second cannula 13, said cannula 12 being in fluid communication with said cavity, and the second cannula 13, which extends along a longitudinal axis A from the connector 2, is being in fluid communication with the tube 14, i.e. cavity as used herein designates the inner lumen of the cannula or the extension of the cannula. The cavity is being positioned in the head part 6 between the first set of guide means 7 and limited by the first surface 10 of the base plate, the insertion needle opening 4 as well as the connector opening 5. I.e. the cavity (not shown) optionally

being covered by a membrane is adapted to receive the second cannula 13 extending from the connector 2.

[0026] In this embodiment, as shown in figures 2, 3 and 6, the cannula 12 is extending from the second surface 11 of the base part 3 along a longitudinal axis B thereby being positioned perpendicular to the skin of the patient. In the alternative, the cannula 12 can extend from the first end 3a of the base part or head part 6 essentially along the axis A or slightly angled in relation to the axis A in order to provide the patient with an infusion set with an inclined insert in a manner known per se as described in WO 94/20160.

Guide means

[0027] As illustrated in e.g. figure 5 and as mentioned in the sections infusion part and connector above, the infusion part 1 and the connector 2 are each provided with corresponding guide means 7,16 for positioning and aligning the infusion part 1 and the connector 2 in relation to each other. The guide means can be in the form of a tongue and groove mechanism. The tongue and groove mechanism can be of different configurations or shapes, for instance it may be in the form of a pater/mater system or the tongue and groove may be formed with a triangular or semi-cylindrical cross sectional area. In this embodiment the first guide means 7 of the infusion part 1 is having the form of two grooves placed symmetrically around the main plane of the base part 3, these grooves 7 being adapted to engage with a second set of corresponding guide means 16 placed on the connector 2, in this embodiment the corresponding second guide means 16 are in the form of two tongues or projecting parts, such as stabilizing fins which fit within the first guide means 7, the guide means 7,16 thereby constituting a tongue and groove system. As an alternative, the first guiding means 7 of the infusion part 1 could be in the form of projecting fins and the second guide means 16 on the connector 2 could be in the form of recesses or grooves.

Second fastening means - retention devices

[0028] The infusion part 1 and the connector 2 are provided with second fastening means for fastening the connector 2 to the infusion part 1. As can be seen in e.g. figure 5, the second fastening means are in the form of connector retention devices 17 positioned in the on the free end of the arms 15 of the connector 2 in adapted to engage with corresponding retention devices 8 positioned in the second end 3b on the base part 3 of the infusion part 1. In this way, the connector 2 is releasably fastened to the infusion part 1.

[0029] When the infusion part 1 and the connector 2 are assembled, the free end of the arms 15, i.e. the second opposite end 2b, is positioned just opposite or above the retention devices 8 in the second end 3b of the base part 3. As shown in figure 5-7 the retention devices 8 in this embodiment are two retention devices 8 extending

from the first surface 10 of the base part 3 for fastening or retention of the connector 2 to the infusion part 1. In this embodiment the retention devices 8 are placed on the far rear end, meaning the second end 3b, of the base part 3 and the connector retention devices 17 of the rear-facing arms 15 are likewise placed on the far rear end, meaning the second end 2b, of the rear-facing arms 15 corresponding to the retention devices 8.

[0030] Accidents involving pulling or tugging in an inclined motion of the tube extending from the connector 2, due to e.g. the tube catching on to something, thereby overloading the infusion set often happens resulting in the infusion set being unintentionally pulled from the skin of the patient. It is essential for the user that at least the infusion part 1 of the infusion set 1,2 remains in place after insertion even when accidents involving pulling or tugging of the tube is involved. The present invention complies with this purpose as the plane of the of the connector 2 can be tilted to a distance from the base plate 3, causing the second end 2b to be displaced to a distance that is larger than the height (h) of the retention devices 8, said retention devices 8 being positioned in the second end 3b of the base part 3, when the connector 2 is positioned via the guide means 7,16 relative to the infusion part 1. As the plane of the connector 2 is displaced, i.e. being inclined from the base part 3, the second end 2b of the connector together with the arms 15 of the connector will be lifted resulting in the connector retention devices 17 being freed from the retention devices 8. Hereby the retention devices 8 and the connector retention devices 17 will be released from each other resulting in the connector 2 disconnecting from the infusion part 1 as opposed to the infusion part 1 being peeled of the skin of the patient.

[0031] In an embodiment of the invention, the second end 2b of the connector 2 can be displaced to a distance from the base plate 3, which distance is larger than the height (h) of the retention devices 8, by making the connector 2 pivot around a point in the guide means 7,16.

Retention devices

[0032] As mentioned above, the displacement of the connector 2 from the main plane of the base plate 3, when the connector 2 is positioned via the guide means 7,16 relative to the infusion part 1, is dependent on the height of the retention devices 8 and the height (h) of the connector retention devices 17. The lower the height of the retention devices 8 and the connector retention devices 17, the less displacement of the second end 2b from the main plane of the base part 3 is needed for releasing the connector 2 from the infusion part 1. The height of the retention devices 8 is again dependent on the shape of the retention devices 8 and the connector retention devices 17 including the contact surface of both the retention devices 8,17.

[0033] In figure 8 different shapes of the retention devices 8 are illustrated. The retention devices 8 are formed

with a contact surface 8a for contact with the opposing contact surface 17a of the corresponding connector retention devices 17 of the arms 15, which opposing contact surface 17a can be seen in figure 8a. The contact surface 8a of the retention devices 8 is extending from the first surface of the base part 3. The contact surfaces 8a have a plane having a projection of the height (h) perpendicular to the main plane of the base part 3. In one embodiment the contact surface 8a of the retention devices 8 is being essentially perpendicular to the main plane of the base part 3, when the infusion part 1 and the connector 2 are connected, i.e. the angle between the contact surface 8a and the base part 3 is approximately 90°. However, the form of the retention devices 8 could also be e.g. as a slope, a chute, a half-circle, a triangle or the like, where the contact surface 8a is being angled relative to the main plane of the base part 3, i.e. that the angle α between the contact surface 8a of the retention devices 8 and the base part 3 is more than 90° as can be seen in figure 8. For each of the mentioned shapes of the retention devices 8 the projection of the height (h) perpendicular to the main plane of the base part 3 can be varied. In this way, it is possible to vary the height of the retention devices 8 on the base part 3 and thereby influence the slipping between the two contact surfaces of the retention devices 8 and the connector retention devices 17 so as to secure that the connector 2 is disconnected from the infusion part 1, when the tube 14 is accidentally pulled in an inclined motion.

[0034] Other shapes than the shapes shown in figure 8 is possible in order to obtain the height of the retention devices 8 which is required or needed for disconnecting the connector 2 from the infusion part 1.

Connector retention devices

[0035] As shown in figure 8a, the connector retention devices 17 of the arms 15 of the connector 2 are as the retention devices 8 formed with a corresponding contact surface 17a which likewise can be formed as e.g. a slope, a chute, a half-circle, a triangle and the like, by triangle is meant that the retention devices shaped as a right-angled triangle when viewed from the side or having a right-angled triangular cross-section, which interlocks or fasten the arms 15 to the retention devices 8 on the base part 3. For each of the mentioned shapes of the connector retention devices 17 the projection of the height perpendicular to the main plane of the connector 2 can be varied. In this way it is also possible to vary the height (h) of the connector retention devices 17 and influence the slipping between the two contact surfaces of the retention devices 8 and the connector retention devices 17 so as to secure that the connector 2 is disconnected from the infusion part 1, when the tube 14 is accidentally pulled in an inclined motion.

[0036] When the infusion part 1 and the connector 2 are assembled, the contact surface 8a of the retention devices 8 and the contact surface 17a of the connector

retention devices 17 are engaged with each other, hereby securing the assembly of the connector 2 and the infusion part 1. Thus, if a pull or a toggle of the tube 14 or of the second end 2b of the connector 2 along the axis A is performed, the retention devices 8 and the connector retention devices 17 will not disengage. In order to intended release the connector 2 from the infusion part 1, the arms 15 of the connector will have to be gripped and pressed to displace the arms axial along and axis in the main plane of the connector and perpendicular to the axis A. In this way the connector retention devices 17 on the arms 15 are freed from the retention devices 8 on the base part 3.

15 Head part

[0037] When the cannula 12 is inserted into the skin of a patient and the insertion angle being perpendicular to the main plane of the base part 3, the head part 6 of the infusion part 1 will normally cover the insertion site. By making the head part 6 of a see-through material such as transparent polypropylene (PP), the head part 6 can function as a window giving the patient or the user a clear view of the place of insertion. By providing a see-through part or a window in the head part 6 of the infusion part 1, the patient or the user therefore can keep the insertion site under observation and at all times determine whether the insertion site or the insertion wound is infected or not or whether the cannula 12 is positioned correctly into the skin of the patient.

[0038] Another way of making the head part 6 of the infusion part 1 sufficiently transparent to get a good visual impression and a clear view of the inserted cannula, is to polish the mould used for making the infusion part 1 before casting the infusion part 1. This renders the mould smooth and assists efforts of both the first and second surface of the head part 6 to be transparent. As another alternative, it is possible to cast the infusion part 1 and afterwards polish the head part 6 of the infusion part 1. As further alternative, it is possible to cast the infusion part 1 with a concavity in the second surface of the head part 6, said second part facing the skin of the patient, so that the thickness of the head part 6 above the insertion place/wound area is decreased or reduced providing better see-through properties and increased view through the head part 6. As a still further alternative, it is possible to either produce the infusion part 1 with a magnifying area or a lens embedded in the head part 6 or to fit or mount a lens in the head part 6 of the infusion part 1 during moulding. This way, when looking through the magnifying area or the lens of the head part 6, a magnified view of the insertion place/wound area is generated.

Gripping means

[0039] In an embodiment, as shown in figure 5-7, the arms 10 of the connector 2 is provided with gripping means 18 in the form of recesses. The gripping means

18 are optional and can be rims, grooves, scores, recesses and pebbled or roughened surface, optionally of another material than the connector itself. This ensures a more simple and easy grip when gripping and pressing the arms of the connector 2 with the first finger and the thumb for fastening or unfastening of the connector 2 from the infusion part 1.

Materials/Plastics

[0040] In another embodiment the infusion part 1 and the connector 2 of the infusion set are made from two different plastics materials, such as two different types of polypropylene. When making the infusion set of different materials it is possible to enhance the different characteristics which are working for each of them. The infusion part 1 is normally quite small and is put in a stationary position during use, which is why it should have a smooth surface and a limited flexibility in order to provide the user with the best comfort. The connector is normally also quite small and is often moved during use, the connector therefore should be easy and comfortable to handle. The infusion part and/or the connector can essentially be made of polypropylene, e.g. such as transparent polypropylene. In this way it is possible to see through the infusion set and thereby being able to see the cannula insertion wound.

Cannula

[0041] The cannula 12 is preferably a soft cannula made of a thermoplastic elastomer (TPE), the TPE's being selected from the group consisting of polyester ethers, ECDEL, styrene based TPE, olefin based TPE, urethane based TPE, ester based TPE, amid based TPE, polyolefin sans silicone rubbers such as polypropylene, C-FLEX™, mixtures of C-FLEX™ and polypropylene, LUPOLEN™ 1840H, LUPOLEN™ 3020D, PELLETHANE™ 2362-75D, PELLETHANE™ 2363-55D, TECOTHANE™ and CARBOTHANE™, but could also be made of metal.

Luer coupling/medical device

[0042] The connector 2 can be connected to a luer coupling member through the tube 14. Through the luer coupling it is possible to administer a suitable therapeutically substance, such as insulin from a pump. The connector can also be a sort of closing part with a suitable entrance for an inserting needle of a syringe. Such a closing part can stay in position for up till three days while the user can have medication, e.g. insulin injected through the entrance in order to reduce trauma to the skin caused by repeated penetration of the skin.

Kit comprising an infusion set and an insertion device

[0043] In another embodiment the invention relates to

a system or a kit, said kit comprises an injector device together with an infusion set according to the invention. The injector device itself is being provided to the patient as a sterile sealed, single use assembly. The injector device is for quick and easy placement of the infusion set and may then be discarded safely.

Injector device

[0044] Figure 10 shows an embodiment of an injector device which can be used with an infusion set in accordance with the invention. The injector device comprises a housing 23, in this embodiment the housing comprises two fastening elements 24 which assures that a plunger 25 cannot rotate in relation to the housing. The plunger 25 is slidably received within the housing 23 for movement between an advanced position and a retracted position, the plunger 25 having substantially non-detachably secured thereto a medical insertion needle (not shown) with a pointed end for receiving and supporting the cannula 12 of the subcutaneous infusion set in a position with the cannula 12, where the insertion needle is removable from the cannula 12 while maintaining a transcutaneous placement of the cannula 12.

[0045] By substantially non-detachably as used in the present application is meant a connection, which will remain stable under normal conditions of use to allow the needle to remain on the plunger 25 when retracting the injector device from the patient's skin.

[0046] The housing 23 of the injector device can also comprise detaining elements 26 in the form of two protruding parts keeping the plunger 25 in a biased position until the plunger are released from the biased position by affecting some release means. The plunger 25 is constructed with a central part 25a and a surrounding part 25b. The central part 25a functions as a finger grip and the surrounding part 25b functions as a drive. The central part 25a can slide between an advanced position and a retracted position in relation to the housing 23 and the infusion part 1 of the infusion set is fastened to the central part 25a. The surrounding part 25b is constructed as two parts formed almost as semicircles, where one end of each semicircle is attached to one of the fastening elements 24 of the housing 23, and the other end of each semicircle is fastened to the central part 25a. The end of the semicircle fastened to the housing 23 at the fastening elements does not move relative to the housing 23 during use. The other end of the semicircle which is attached to the central part 25a is pulled out of the housing 23 (arrows for direction in fig. 10). When pulling in the central part 25a, the surrounding part 25b which functions as a drive, will be tightened. The surrounding part 25b is kept in the biased position by two protrusions 27 (only one shown). The protrusions 27 are in this embodiment attached to a connecting wall 28, but could just as well be attached to the central part 25a. When the central part is pulled out of the housing 23, the protrusions 27 will be pulled past the detaining elements 26 and these elements will pre-

vent the protrusion 27 and thereby the central part 25a from returning to a relaxed position inside the housing 23.

[0047] The housing 23 can be released by pressing on the sides of the housing at a line perpendicular to the line formed by the two detaining elements 26 (direction indicated by arrows on figure 10). When pressing at the two opposite sides in this position, the resulting deformation of the housing will cause the two detaining elements 26 to be pushed away from each other, thereby leaving enough room for the protrusions 27 to pass by the detaining elements 26 and for the central part 25a to be forced back into the relaxed position by the drive in the form of the surrounding part 25b.

[0048] The insertion needle may be connected to the plunger 25 in any suitable manner such as in the process of moulding the plunger, or the insertion needle may be press-fit in the plunger 24. The insertion needle may be oriented at an angular position relative to the skin of the patient so as to make an insertion perpendicular to the skin of the patient or so as to make an inclined insertion.

[0049] The housing 23 may have a circular, square or any desired cross-sectional shape. The housing 23 and the plunger 24 are advantageously formed of a plastics material in a moulding process.

Other injector devices

[0050] Other injector devices than described here can be used together with the infusion set according to the invention but it is necessary that it is possible to adapt the infusion part 1 of the infusion set and to keep it in position until insertion has taken place.

Manually insertion

[0051] Whether the infusion set is intended to be inserted manually or by an injector the infusion part 1 and the connector 2 can be delivered to the user as two separate units. When inserted manually the infusion part 1 will at delivery be combined with a needle unit with the same locking and guiding means as the connector. The needle unit is provided with an insertion needle extending from the central front which insertion needle at delivery extends through and beyond the end of the cannula. The needle unit's only function will be to penetrate the user's skin where after the needle unit is removed and replaced with the connector leaving the cannula subcutaneous.

Other medical devices

[0052] As mentioned above, the connector 2 can be coupled via the tube 14 to a pump for administering a therapeutically substance such as insulin. However, the connector 2 can be replaced with a dummy connector or dummy part, which dummy part is shaped to correspond to the connector 2 but without the tube 14 in the second end 2b of the connector 2. In this way, a patient can disconnect the real connector 2 and replace the real con-

connector 2 with said dummy part, a consequence hereof being that the pump for administering medicines or a therapeutically substance likewise will be disconnected from the patient's infusion set. When the patient is wearing the dummy part or dummy connector and is in need of medication or a therapeutically substance, the patient can e.g. inject the medication or a therapeutically substance through the insertion needle opening 4 in the infusion part 1 directly into the cannula 12 by means of e.g. a syringe.

[0053] In this way, it is easier for the patient to leave the house for a shorter period of time without the inconvenience of having to bring unmanageable medical equipment such as the above mentioned pump for administering medicines, but still be able to inject medicines or a therapeutic substance by use of e.g. a small syringe when needed.

[0054] The invention has been described with reference to particular embodiments. Many modifications can be carried out without thereby deviating from the scope of the invention.

Claims

1. An infusion set for intermittent administration of a therapeutically substance through the skin of a patient, comprising:

- an infusion part (1) comprising a base part (3) having a main plane, a head part (6) extending from the main plane of the base part (3) and a cannula (12) extending from the base part (3) into the skin of a patient,

- first fastening means for fastening the infusion part (1) to the skin of a patient,

- a connector (2) having a plane being parallel to and above the main plane of the base part (3), and having one or more arms (15), said arms (15) being fastened to the connector (2) at a first end (2a), and being free in a second opposite end (2b), and a tube (14) positioned in the second end (2b) for connecting the infusion set to a medical device,

- guide means (7, 16) for positioning the infusion part (1) and the connector (2) in relation to each other,

- second fastening means for fastening the connector (2) to the infusion part (1), said second fastening means being in the form of projecting connector retention devices (17) positioned on the arms (15) of the connector (2) adapted to engage with retention devices (8) extending from the base part (3),

wherein the plane of the connector (2) can be tilted to a distance from the base part (3), causing the second end (2b) to be displaced to a distance that is

- larger than the height (h) of the retention devices (8), said retention devices (8) being positioned in the second end (3b) of the base part 3, when the connector (2) is positioned via the guide means (7,16) relative to the infusion part (1).
2. An infusion set according to claim 1, wherein the connector (2) is pivotable at the first end (2a) when positioned in the guide means (7,16) around an axis, said axis being parallel to the main plane of the base part (3) and perpendicular to a longitudinal axis A of the infusion part.
 3. An infusion set according to claim 1 or 2, wherein the cannula (12) of the infusion part (1) is extending perpendicular to and from the lower surface (11) of the base part (3).
 4. An infusion set according to any of the claims 1-3, wherein the retention devices (8) of the infusion part (1) are formed with contact surfaces (8a) for engaging with corresponding contact surfaces (17a) of the connector retention devices (17), which contact surfaces (8a) have a plane having a projection of the height (h) perpendicular to the main plane of the base part (3).
 5. An infusion set according to claim 4, wherein the contact surface (8a) of the retention devices (8) is essentially perpendicular to the base part (3):
 6. An infusion set according to the claims 1-5, wherein the contact surface (17a) of the connector retention devices (17) of the arms (15) is being essentially perpendicular to the main plane of the base part (3), when the infusion part (1) and the connector (2) are assembled.
 7. An infusion set according to claim 1, wherein the first fastening means is a mounting pad.
 8. An infusion set according to claim 7, wherein the mounting pad is an adhesive dressing.
 9. An infusion set according to claim 1, wherein the guide means for positioning the infusion part (1) and the connector (2) relative to each other is in the form of a tongue and groove connection.
 10. An infusion set according to claim 9, wherein the groove is positioned on the head part (6) of the infusion part (1) and the tongue is positioned on the connector part (2).
 11. An infusion set according to claims 1-10, wherein the head part (6) of the infusion part (1) is provided with a see-through part.
 12. An infusion set according to claim any of the claims 1-11, wherein the head part (6) of the infusion part (1) is made of transparent polypropylene.
 13. An infusion set according to any of the claims 1-12, wherein the see-through part of the head part is formed by reducing the thickness of the head part (6).
 14. An infusion set according to any of the claims 1-13, wherein the see-through part of the head part (6) is provided with a magnifying area.
 15. An infusion set according to any of the proceeding claims 1-14, wherein the arms (15) of the connector (2) are provided with gripping means (18) for easy gripping when pressing the arms (15) for disconnection of the connector (2) from the infusion part (1).
 16. An infusion set according to any of the proceeding claims 1-15, wherein the infusion part (1) and the connector (2) are made from two different plastics materials.
 17. An infusion set according to any of the proceeding claims 1-16, wherein the infusion part (1) and/or the connector (2) essentially is made from polypropylene.
 18. An infusion set according to any of the proceeding claims 1-17, wherein the medical device is an insulin pump.
 19. A kit comprising an injector device and an infusion set according to any of the claims 1-17 where the injector device comprises:
 - a housing (23)
 - a plunger (25) slidably received within the housing (23) for movement between an advanced position and a retracted position, the plunger (25) having substantially non-detachably secured thereto an insertion needle for receiving and supporting the cannula (12) of the subcutaneous infusion set (1,2) in a position with the cannula (12), where the insertion needle is removable from the cannula (12) while maintaining a transcutaneous placement of the cannula (12),
 - a drive (25b) for urging the plunger (25) from the retracted position toward the advanced position to transcutaneously place said cannula (12) of the infusion set (1,2) received on the insertion needle.

Figure 2

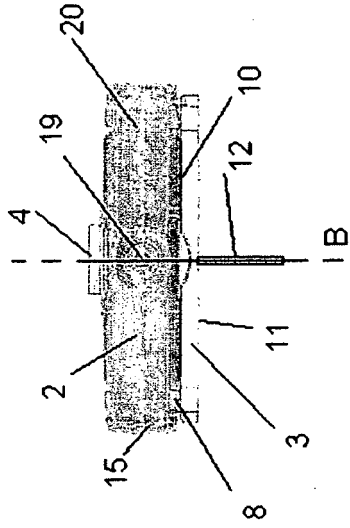

Figure 1

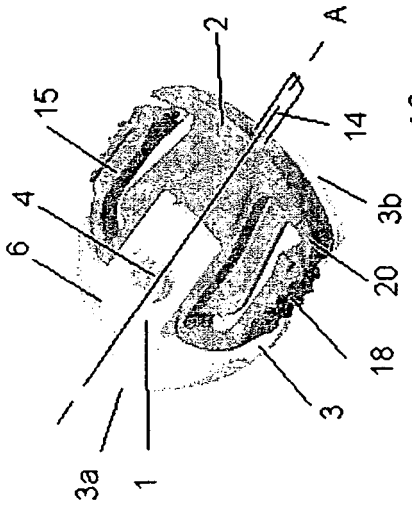

Figure 4

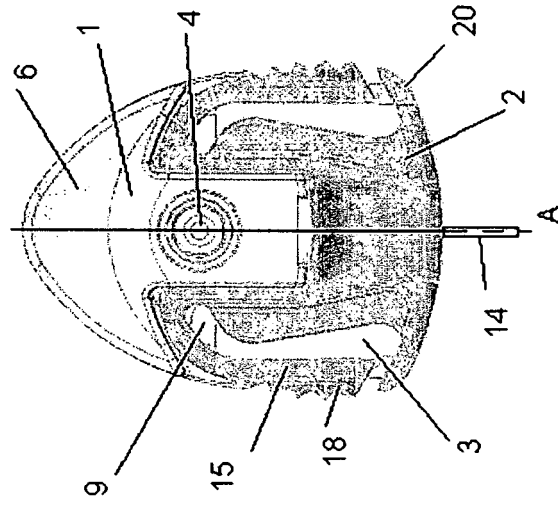
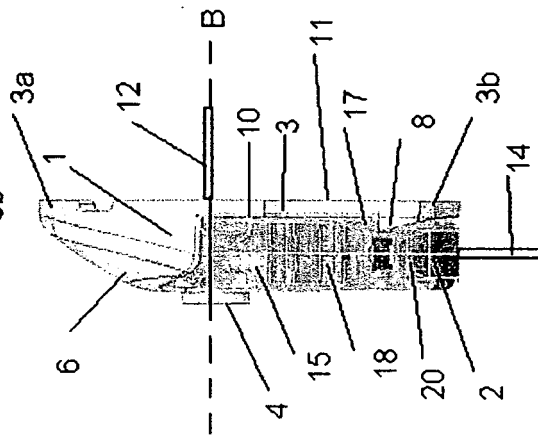

Figure 3



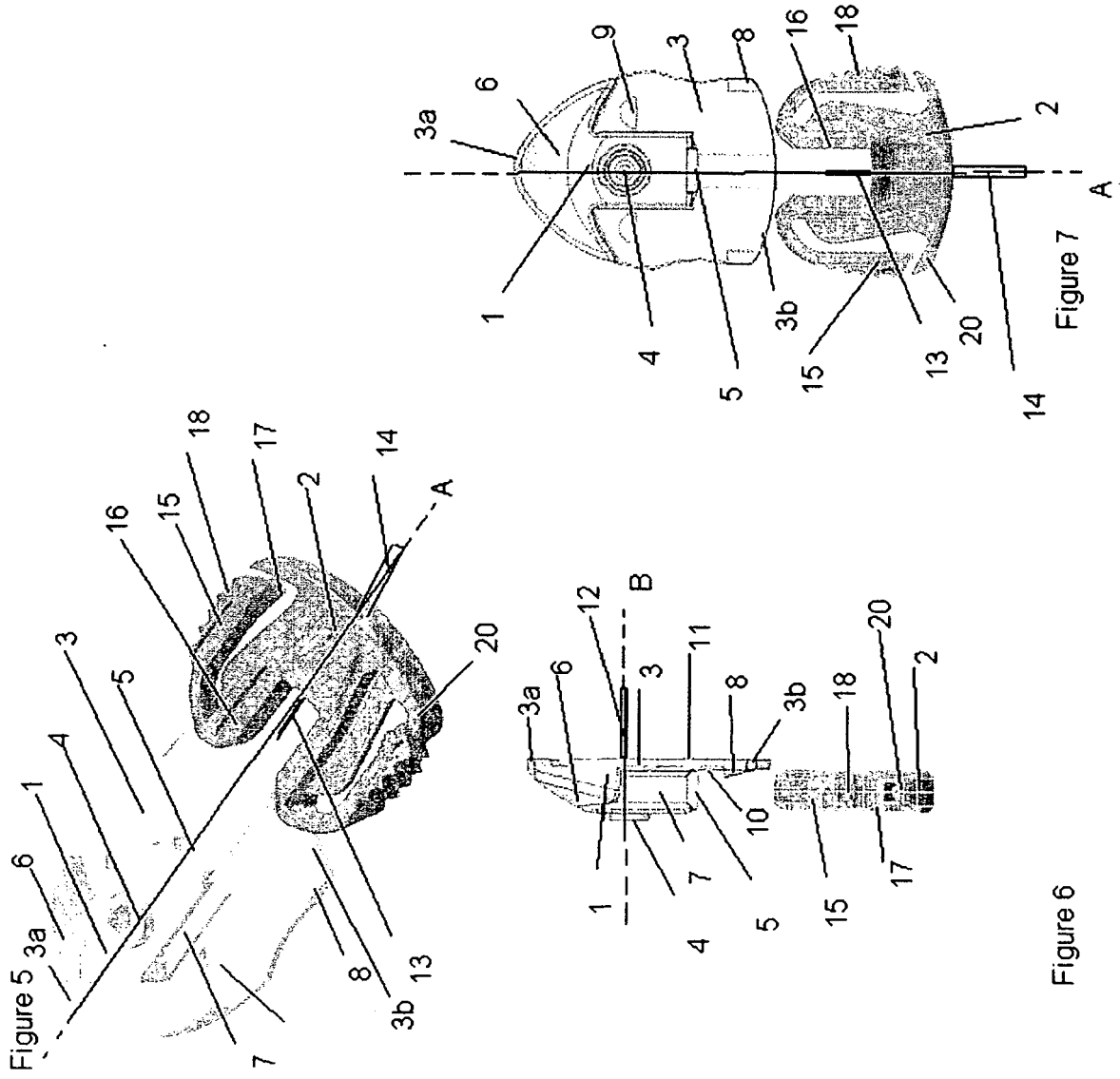

Figure 6

Figure 7

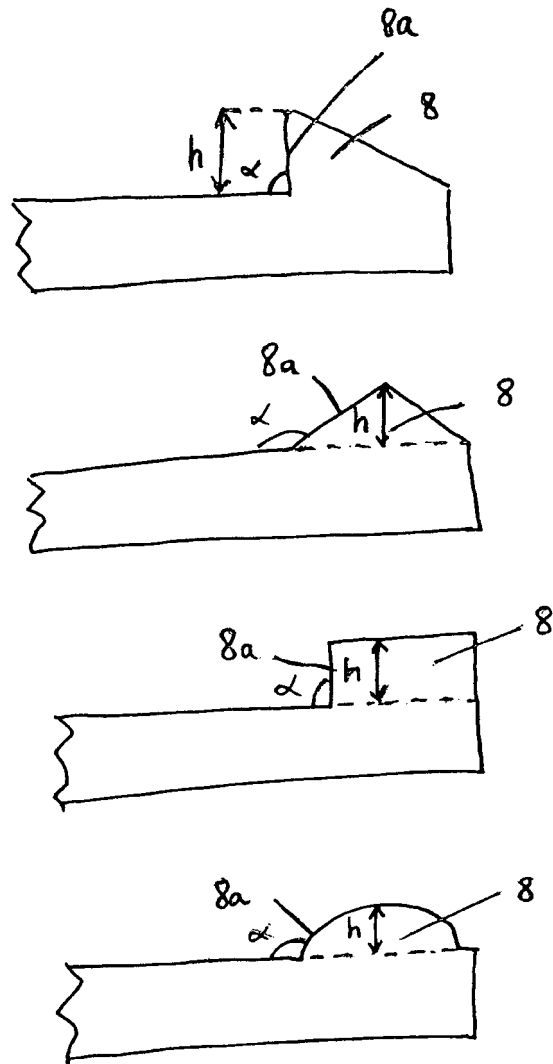

Figure 8

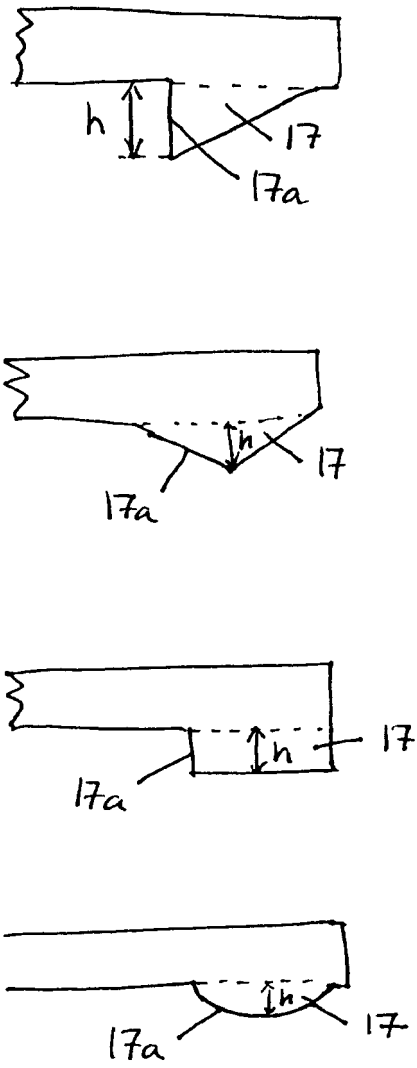

Figure 8a

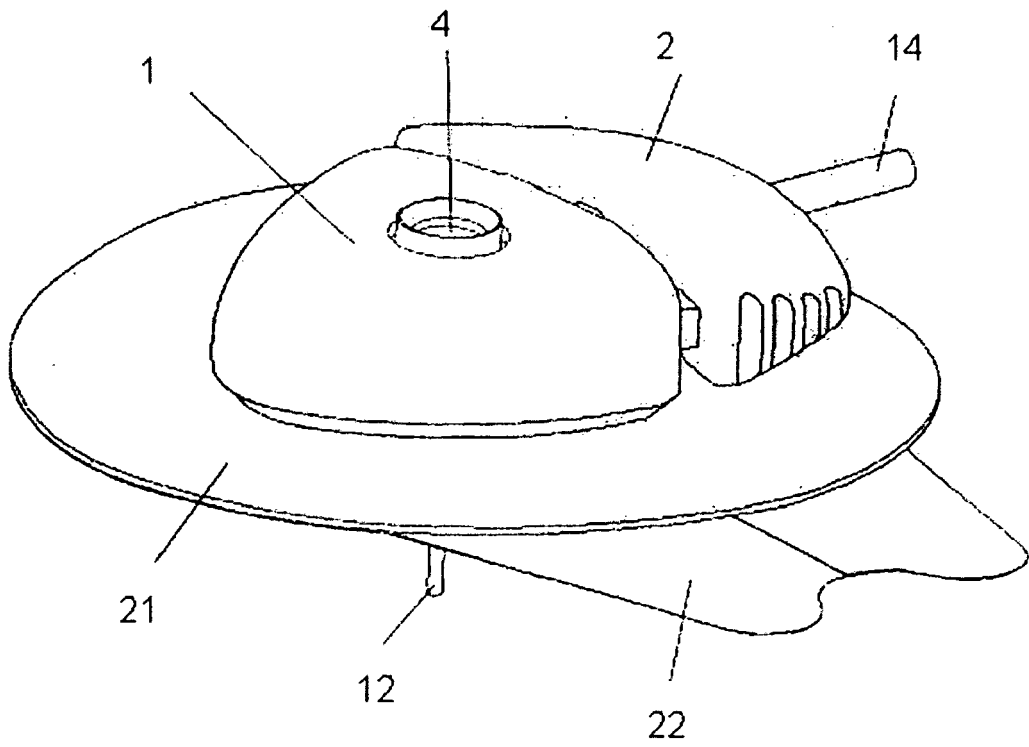

Figure 9

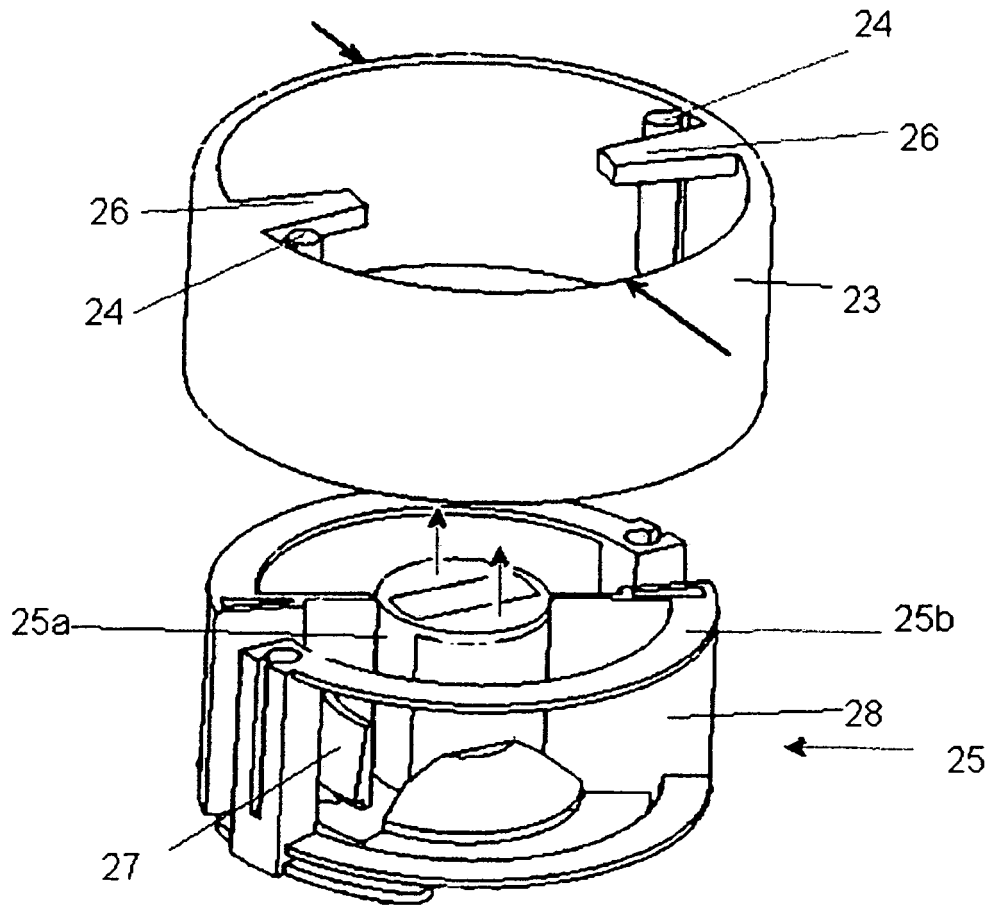

Figure 10



DOCUMENTS CONSIDERED TO BE RELEVANT			
Category	Citation of document with indication, where appropriate, of relevant passages	Relevant to claim	CLASSIFICATION OF THE APPLICATION (IPC)
D,A	WO 2005/092410 A (UNOMEDICAL AS [DK]; KORNERUP GRETE [DK]; MOGENSEN LASSE WESSELTOFT [DK]) 6 October 2005 (2005-10-06) * page 10, line 7 - page 11, line 4 * * page 11, line 32 - page 12, line 28 * * figures 1-3 *	1	INV. A61M5/158 A61M39/10 A61M25/02
A	WO 02/07804 A (ANIMAS CORP [US]) 31 January 2002 (2002-01-31) * page 9, line 26 - page 10, line 13 * * figures 1-18 *	1	
A	WO 02/068014 A2 (STERLING MEDIVATIONS INC [US]) 6 September 2002 (2002-09-06) * paragraph [0037] * * figures 1-3 *	1	
A	EP 1 618 908 A1 (CLINICO GMBH [DE]) 25 January 2006 (2006-01-25) * paragraphs [0022], [0025], [0028] * * figures *	1	
The present search report has been drawn up for all claims			TECHNICAL FIELDS SEARCHED (IPC)
			A61M
Place of search		Date of completion of the search	Examiner
Berlin		4 April 2007	Schultz, Ottmar
<p>CATEGORY OF CITED DOCUMENTS</p> <p>X : particularly relevant if taken alone Y : particularly relevant if combined with another document of the same category A : technological background O : non-written disclosure P : intermediate document</p> <p>T : theory or principle underlying the invention E : earlier patent document, but published on, or after the filing date D : document cited in the application L : document cited for other reasons</p> <p>& : member of the same patent family, corresponding document</p>			

2
EPO FORM 1503 03.82 (P04C01)

ANNEX TO THE EUROPEAN SEARCH REPORT
ON EUROPEAN PATENT APPLICATION NO.

EP 06 02 2674

This annex lists the patent family members relating to the patent documents cited in the above-mentioned European search report. The members are as contained in the European Patent Office EDP file on
The European Patent Office is in no way liable for these particulars which are merely given for the purpose of information.

04-04-2007

Patent document cited in search report	Publication date	Patent family member(s)	Publication date
WO 2005092410 A	06-10-2005	CA 2560784 A1	06-10-2005
		CA 2560788 A1	06-10-2005
		WO 2005092411 A1	06-10-2005
		EP 1727576 A1	06-12-2006
		EP 1727577 A1	06-12-2006
		KR 20060128005 A	13-12-2006
		KR 20060131888 A	20-12-2006
		US 2005215979 A1	29-09-2005
WO 0207804 A	31-01-2002	AU 7031701 A	05-02-2002
		CA 2417183 A1	31-01-2002
		EP 1305068 A1	02-05-2003
		JP 2004504116 T	12-02-2004
		US 6572586 B1	03-06-2003
WO 02068014 A2	06-09-2002	AU 2002243842 A1	12-09-2002
		EP 1397177 A2	17-03-2004
		JP 2004536623 T	09-12-2004
EP 1618908 A1	25-01-2006	AT 346626 T	15-12-2006
		DE 202004011617 U1	07-10-2004
		US 2006030815 A1	09-02-2006

REFERENCES CITED IN THE DESCRIPTION

This list of references cited by the applicant is for the reader's convenience only. It does not form part of the European patent document. Even though great care has been taken in compiling the references, errors or omissions cannot be excluded and the EPO disclaims all liability in this regard.

Patent documents cited in the description

- WO 2005092410 A1 [0005]
- WO 9420160 A [0026]