

(19)  
(12)

(KR)  
(B1)

(51) 。 Int. Cl. <sup>6</sup>  
H01J 9/38

(45)  
(11)  
(24)

2002 04 06  
10 - 0331533  
2002 03 25

(21) 10 - 1999 - 0034075  
(22) 1999 08 18

(65) 2001 - 0018212  
(43) 2001 03 05

(73)

20

(72)

101 - 1006

(74)

:

(54)

가

가

A/B × 100(%)

, A:  
20 40%

190 235 ,

, B:

5

1 .  
 2 .  
 3 .  
 4 .  
 5 .  
 \*\*\* \*\*\*

1 : , 2 : , 3 : , 15 :

가 , ,

가  $10^{-7}$  Torr

1 .

(2), (2) R, G, B (3) , (3)  
 (In - line) (6) (4) (1) 3  
 (3) (R), (G), (B) 가 (Stripe) (D  
 ot) (7) (7) (5) (9) (  
 0.12 .22mm) (8)가 (7) (11) (  
 10) (14) (11) .  
 , (9) (5) (地磁界) 가  
 (6) (5) (12)가 / (1) (2)  
 (7) (13)가

가

2

(3) (14) (3) (15)

(x 100) 가 140% (Wedge) ( 가 /

(A) 60% (B) (15) (A

/B x 100)

3

140%

60%

4

(flat)

( 1 190

00,000mm ), 가

가 가

가

가 190 235 :

, B: A/B x 100(%) , A:

20 40%

(W) (L) , W L/2

가

가 , 가

10<sup>-7</sup> Torr 10,000mm 가

(15) (3)

100%

(15) (W) (15) (15) (15) 5 (15) 40% 20 40% (15) (W) 가 가 20%

(L) 1/2 가

5 (15) (W)

(W) (L) 1/2

가

가

(57)

1.

190 235

가 ,

$$A/B \times 100(\%)$$

A:

, B:

20 40%

2.

1

(W) (L) , W L/2

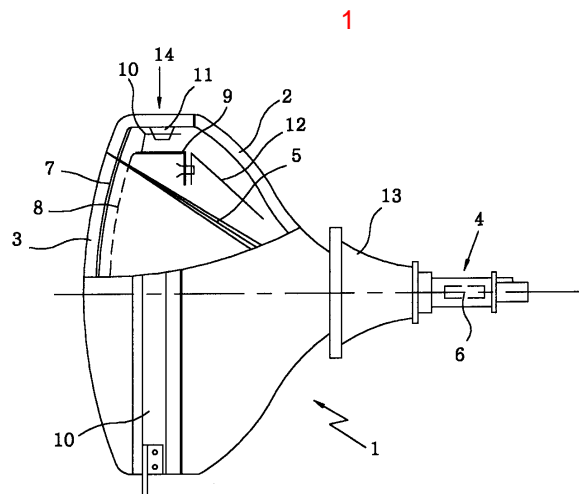

2

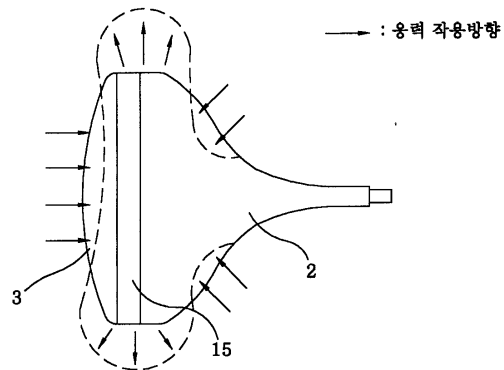

3

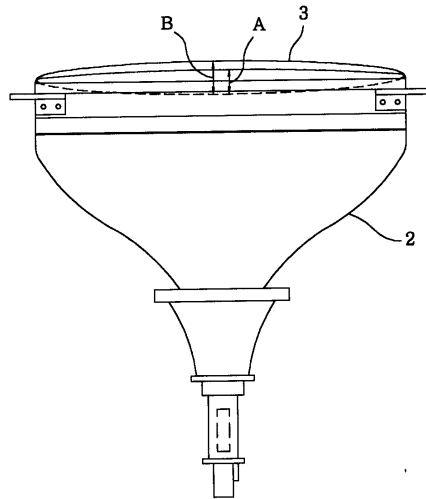

4

