



US 20040069792A1

(19) **United States**

(12) **Patent Application Publication**
Schaal

(10) **Pub. No.: US 2004/0069792 A1**

(43) **Pub. Date: Apr. 15, 2004**

(54) **HOLDER FOR A BEVERAGE CONTAINER**

Publication Classification

(76) Inventor: **Falk Schaal, Alpirsbach (DE)**

(51) **Int. Cl.⁷ B65D 25/00**

Correspondence Address:
STRIKER, STRIKER & STENBY
103 East Neck Road
Huntington, NY 11743 (US)

(52) **U.S. Cl. 220/737**

(21) Appl. No.: **10/617,973**

(57) **ABSTRACT**

(22) Filed: **Jul. 11, 2003**

(30) **Foreign Application Priority Data**

A holder for beverage containers has a pot-shaped container receptacle for receiving a beverage container, a holding ring, a guideway arranged on the container receptacle and formed so as to guide the holding ring for movement up and down between a lowered position and a raised position.

Jul. 12, 2002 (DE)..... 102 31 519.1

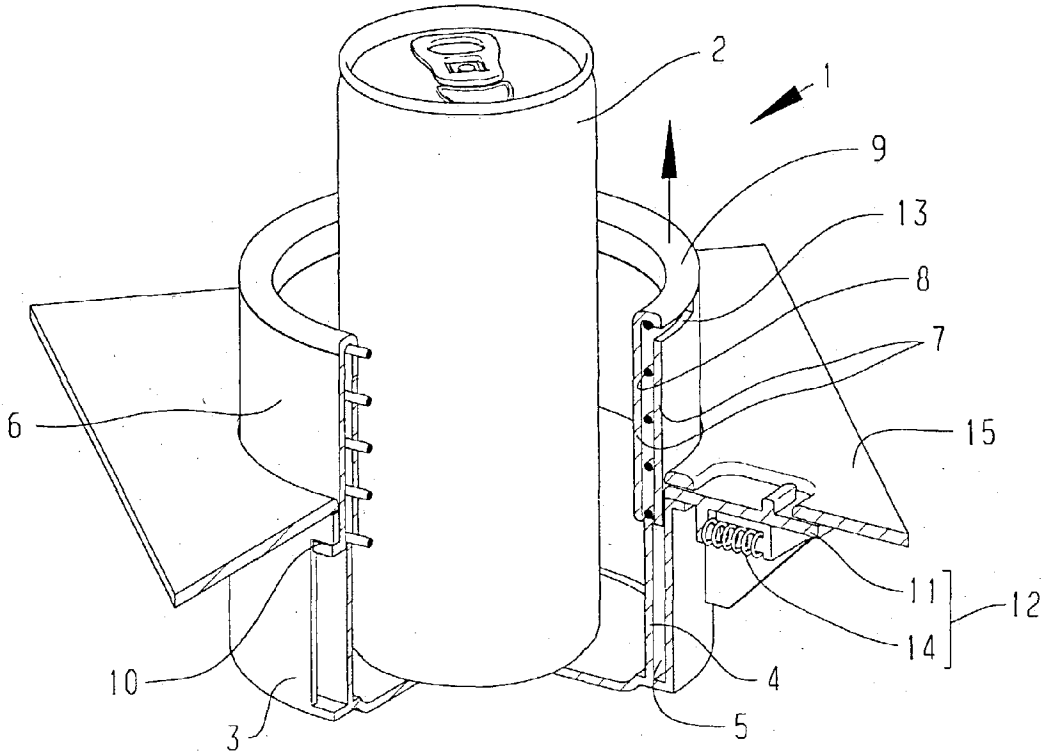

Fig. 1

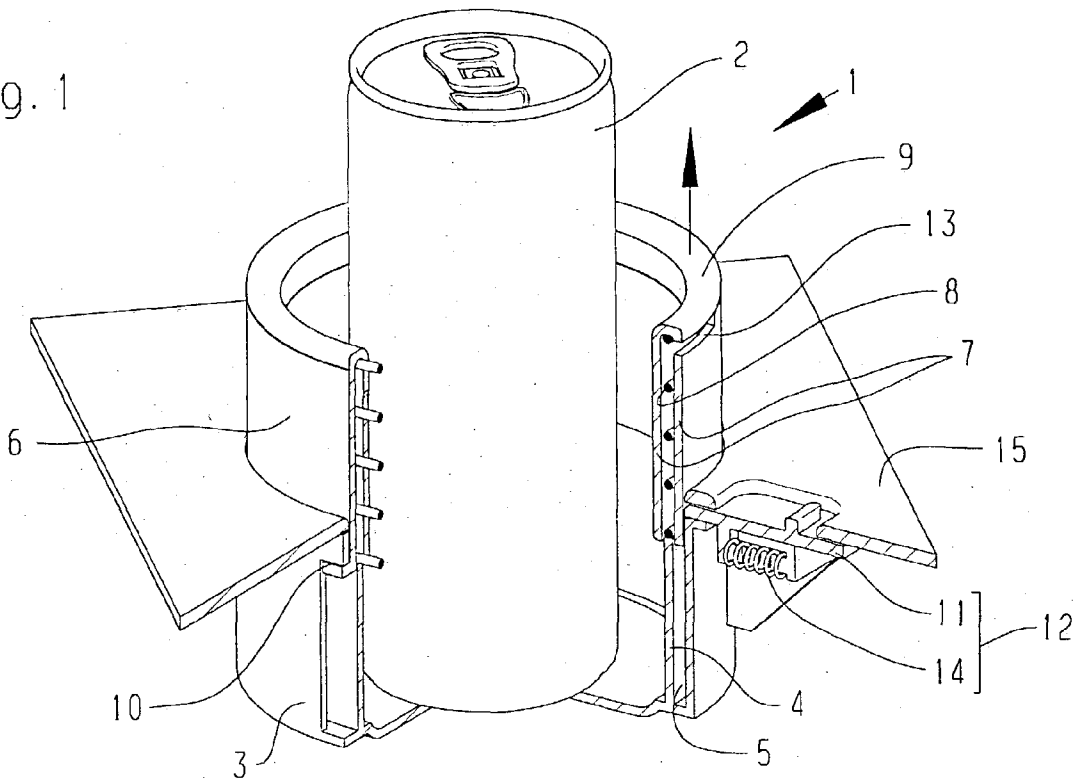

Fig. 2

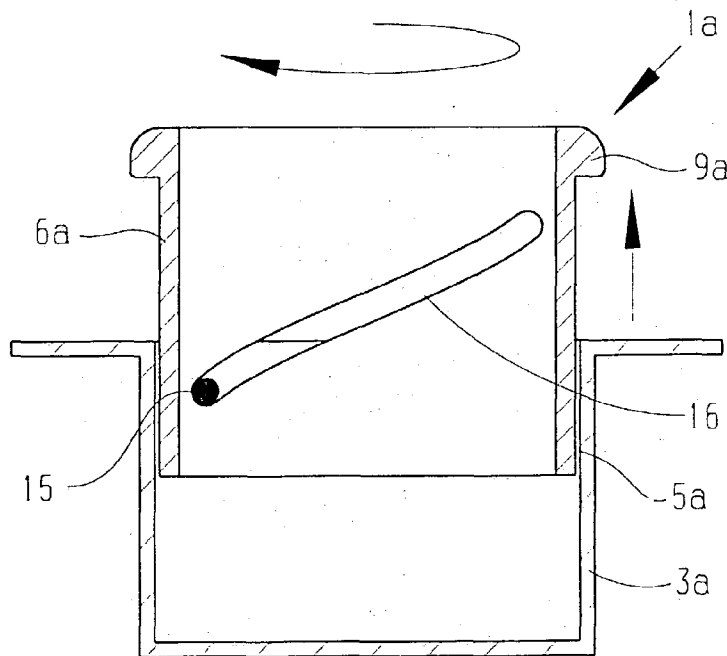
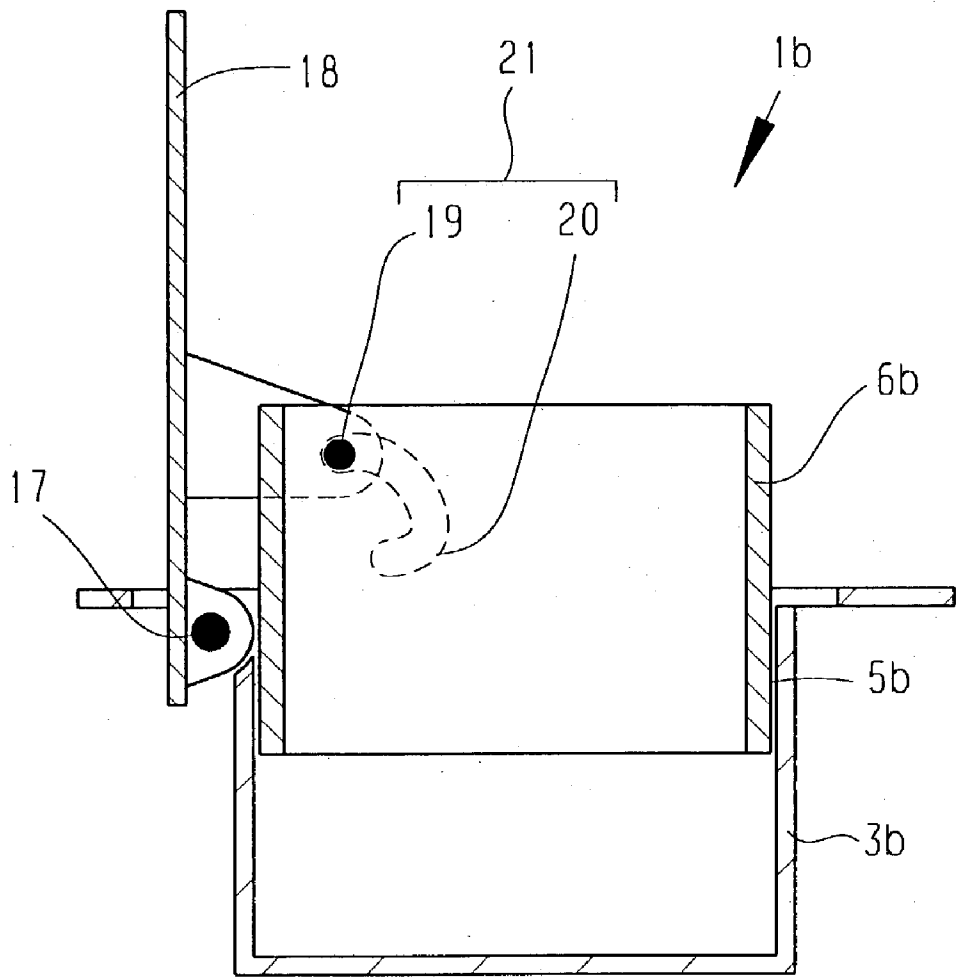

Fig. 3



HOLDER FOR A BEVERAGE CONTAINER

BACKGROUND OF THE INVENTION

[0001] The present invention relates to a holder for a beverage container. The holder is intended for installation in a vehicle for the purpose of holding beverage cans, bottles or the like.

[0002] A large number of such holders having a post-shaped container receptacle are known from the prior art. Appropriate recesses are accordingly arranged, for example, in the region of the central console of motor vehicles, although it is frequently a problem that an adequate insertion depth for tall beverage containers such as bottles cannot be achieved because of a lack of space.

SUMMARY OF THE INVENTION

[0003] It is therefore an object of the present invention to provide a holder for a beverage container, which holder can achieve a large insertion depth in a small installation space.

[0004] In keeping with these objects and with others which will become apparent hereinafter, one feature of the present invention resides, briefly stated in a holder for beverage containers, comprising a pot-shaped container receptacle for receiving a beverage container; a holding ring; a guideway arranged on said container receptacle and formed so as to guide said holding ring for movement up and down between a lowered position and a raised position.

[0005] In accordance with the invention, the container receptacle insertion depth is increased by means of a holding ring. The holding ring is guided between a lowered position and a raised position by means of a guideway arranged on the container receptacle. The container receptacle then needs to have only shallow depth, for example only a third of the height of a beverage can. As a result, installation in, for example, the region of the central console is possible even when space inside the central console is restricted. At the same time, when the holding ring is in the lowered position it hardly protrudes, or does not protrude at all, above the panel surrounding the holder and accordingly does not represent an obstacle.

[0006] Very short beverage containers, for example small cardboard beakers, are nevertheless already held sufficiently well by the holder when the holding ring is in that lowered position. For the purpose of holding relatively tall beverage containers, the holding ring is raised. In that position, it provides good hold. In addition to the small installation space, the advantage is accordingly obtained that the insertion depth can be matched to various sizes of beverage containers.

[0007] In accordance with a preferred embodiment, the holder has a spring element which raises the holding ring. In order to be able to hold the holding ring in the lowered position, a locking mechanism is additionally provided, which holds the holding ring against the force of the spring element. To raise the holding ring, the locking mechanism is released, as a result of which the holding ring is raised automatically. For lowering, the holding ring is pushed down manually until the locking mechanism locks into place.

[0008] In a particular embodiment of the present invention, the spring element can be in the form of a compression spring. It is inserted between the two walls of a double-walled holding ring.

[0009] In accordance with the invention, a projection can be arranged on the container receptacle, which projection engages in a helical groove arranged in the holding ring. As a result, the holding ring can be moved up and down by means of a rotary movement with respect to the container receptacle. That can, as described above, be combined with a spring element in conjunction with a locking mechanism. Besides that, it is also possible, however, for self-limitation to occur as a result of the formation of the groove, at least when in the raised position. In that case, the holding ring is both lowered and raised manually. It is to be understood that without departing from the concept of the invention, it is also possible for the projection to be arranged on the holding ring and the groove to be arranged on the container receptacle.

[0010] Alternatively, both raising and lowering of the holding ring can be accomplished indirectly by way of a holder cover which can be pivoted open. For that purpose, the cover and the holding ring are linked to one another by means of a control track arrangement. A control projection can be arranged on the cover and engage in a curved control track on the holding ring. Opening the cover causes the holding ring, guided by the guideway on the container receptacle, to be pulled up. Vice-versa, the holding ring is lowered when the cover is closed.

[0011] The novel features which are considered as characteristic for the present invention are set forth in particular in the appended claims. The invention itself, however, both as to its construction and its method of operation, together with additional objects and advantages thereof, will be best understood from the following description of specific embodiments when read in connection with the accompanying drawings.

BRIEF DESCRIPTION OF THE DRAWINGS

[0012] **FIG. 1** is a perspective cut-away view of the holder in accordance with the present invention; and

[0013] **FIGS. 2 and 3** are cross-sectional views of further exemplary embodiments of the holder in accordance with the present invention.

DESCRIPTION OF THE PREFERRED EMBODIMENTS

[0014] A holder **1** shown in **FIG. 1**. It is intended for installation in a motor vehicle, for example in the region of the central console. The holder **1** is used for insertion of a beverage container such as, for example, the beverage can **2** illustrated. For accommodation thereof, the holder **1** has a container receptacle **3**. Arranged on the latter is an encircling rib **4** for formation of a guideway **5** for a double-walled holding ring **6**.

[0015] The holding ring **6** is shown in the raised position. It is held in that position by means of the compression spring **8** inserted between the walls **7**. One end of the compression spring bears against the encircling rib **4** of the container receptacle **3** and the other end bears against the inside of the upper rim **9** of the holding ring **6**. In order to limit the displacement of the holding ring **6** in an upwards direction, a stop **10** is provided both on the holding ring **6** and on the container receptacle **3**.

[0016] For lowering, the upper rim **9** of the holding ring **6** is pressed down manually until the detent **11** of the locking

mechanism **12** engages in the detent groove **13** on the holding ring **6**. The detent **11** is held in that position by the spring **14**. In the lowered position, the upper rim **9** of the holding ring **6** is, in the vertical direction, flush with the surrounding panel **15**. In order to release the detent **11**, it is moved manually against the force of the spring **14**, as a result of which the holding ring **6** is raised by the compression spring **8**.

[0017] The holding ring **6** is made, on the one hand, from a hard plastics components which provides the requisite stability and, on the other hand, from a softer component at the upper rim **9**. The two components are joined together by an integral materials-based connection, that is, for example, are manufactured by two-component injection moulding. The soft upper rim **9** serves for damping jolts which can, for example, be produced whilst driving. The raising and lowering movement may also be damped, for example by arranging a rotary damper, comprising a toothed wheel, on the container receptacle in conjunction with a toothed rack on the holding ring (not illustrated).

[0018] FIG. 2 shows an alternative embodiment of the invention. The holder **1a** shown has a container receptacle **3a**, on which there is arranged a projection **15**. The projection **15** engages in a helical groove **16** arranged on the holding ring **6a**. Rotation of the upper rim **9a** causes the holding ring **6a** to be raised and lowered, and the projection **15** is guided in the groove **16**. Friction between the projection **15** and groove **16** ensures that gravity does not cause lowering of the holding ring **6a** when it is in the raised position shown.

[0019] FIG. 3 shows a further alternative embodiment of the holder **1b**. The cover **18** for closing the holder **1b** is mounted on the container receptacle **b** by means of the pivotal mounting **17**. Mounted on the cover **18** is a control projection **19**, which engages in a curved control track **20** arranged on the holding ring **6b**. As a result, the cover **18** and the holding ring **6b** are positively connected in the form of a control track arrangement **21**. The holding ring **6b** is raised and lowered as a result of the opening and closing, respectively, of the cover **18**. The holding ring **6b** can be made to stay in the raised position shown by means of appropriate frictional conditions in the control track arrangement **21**, in the pivotal mounting **17** and/or in the guideway **5b** of the holding ring **6b** in the container receptacle **3b**. Alternatively, a detent mechanism (not shown) can be provided.

[0020] It will be understood that each of the elements described above, or two or more together, may also find a useful application in other types of constructions differing from the types described above.

[0021] While the invention has been illustrated and described as embodied in holder for a beverage container, it is not intended to be limited to the details shown, since various modifications and structural changes may be made without departing in any way from the spirit of the present invention.

[0022] Without further analysis, the foregoing will so fully reveal the gist of the present invention that others can, by applying current knowledge, readily adapt it for various applications without omitting features that, from the standpoint of prior art, fairly constitute essential characteristics of the generic or specific aspects of this invention.

What is claimed as new and desired to be protected by Letters Patent is set forth in the appended claims.

1. A holder for beverage containers, comprising a pot-shaped container receptacle for receiving a beverage container; a holding ring; a guideway arranged on said container receptacle and formed so as to guide said holding ring for movement up and down between a lowered position and a raised position.

2. A holder as defined in claim 1; and further comprising a spring element which raises said holding ring; and a releasable locking mechanism which in a locked state holds said holding ring in said lowered position against a force of said spring element.

3. A holder as defined in claim 2, wherein said spring element is formed as a compression spring.

4. A holder as defined in claim 3, wherein said compression spring of said spring element is arranged between walls.

5. A holder as defined in claim 1, wherein said holding ring has a helical groove, said container receptacle having a projection which engages in said helical groove of said holding ring.

6. A holder as defined in claim 1; and further comprising a cover arranged to be pivoted open; and a control track arrangement which connects said holding ring and has a control projection arranged on said cover and a curved control track arranged on said holding ring.

* * * * *