



US00D504378S

(12) **United States Design Patent**
Grossenbacher et al.

(10) **Patent No.:** **US D504,378 S**

(45) **Date of Patent:** **** Apr. 26, 2005**

(54) **VEHICLE WHEEL**

(75) Inventors: **John L. Grossenbacher**, Cuyahoga Falls, OH (US); **Donald A. Hohman**, Akron, OH (US); **Steven F. Spiegel**, Edinboro, PA (US)

(73) Assignee: **Accuride Corporation**, Evansville, IN (US)

(**) Term: **14 Years**

(21) Appl. No.: **29/177,546**

(22) Filed: **Mar. 11, 2003**

(51) **LOC (7) Cl.** **12-16**

(52) **U.S. Cl.** **D12/209**

(58) **Field of Search** D12/204-213;
301/37.101, 64.101, 65

(56) **References Cited**

U.S. PATENT DOCUMENTS

D97,554 S * 11/1935 Hunt D12/209

D99,805 S	*	5/1936	Horn	D12/209
D103,778 S	*	3/1937	Hunt	D12/209
D103,779 S	*	3/1937	Hunt	D12/209
D232,930 S	*	9/1974	Edwards	D12/209
D356,538 S	*	3/1995	Botterman	D12/209
D358,797 S	*	5/1995	Botterman	D12/209
D361,052 S	*	8/1995	Clements et al.	D12/209
D388,760 S	*	1/1998	Sacco et al.	D12/209
D397,662 S	*	9/1998	LeJuerne	D12/209
D408,776 S	*	4/1999	Sacco et al.	D12/209
D445,751 S	*	7/2001	Pfeiffer et al.	D12/209

* cited by examiner

Primary Examiner—Stacia Cadmus

(74) *Attorney, Agent, or Firm*—Kilgannon & Steidl

(57) **CLAIM**

We claim the ornamental design for vehicle wheel, as shown.

DESCRIPTION

FIG. 1 is a front elevation of a vehicle wheel; and, FIG. 2 is a sectional view through lines 2—2 of FIG. 1.

1 Claim, 2 Drawing Sheets

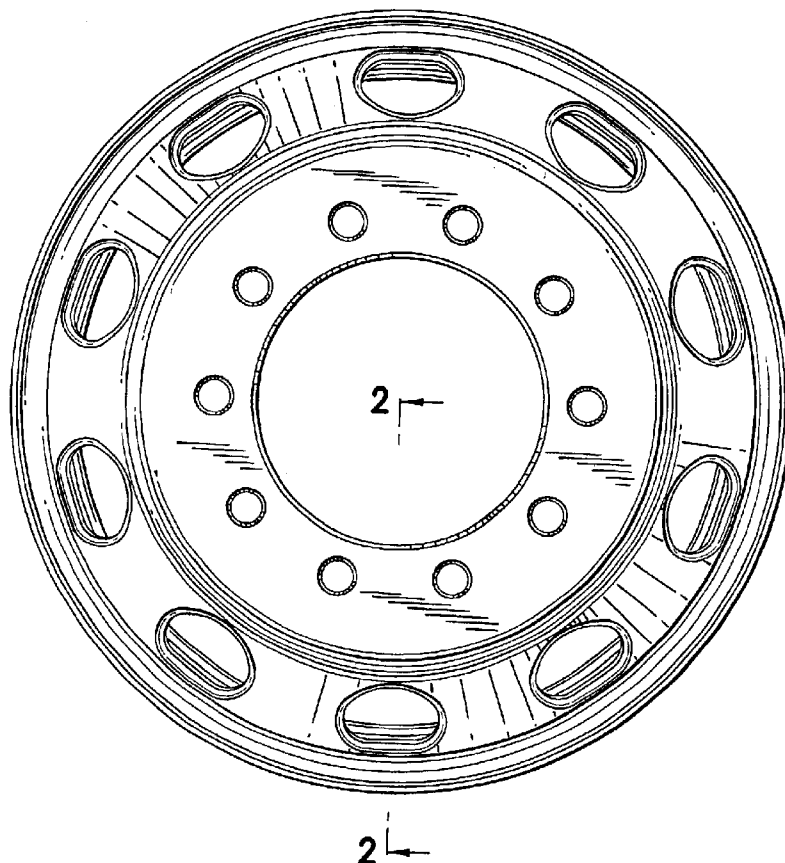

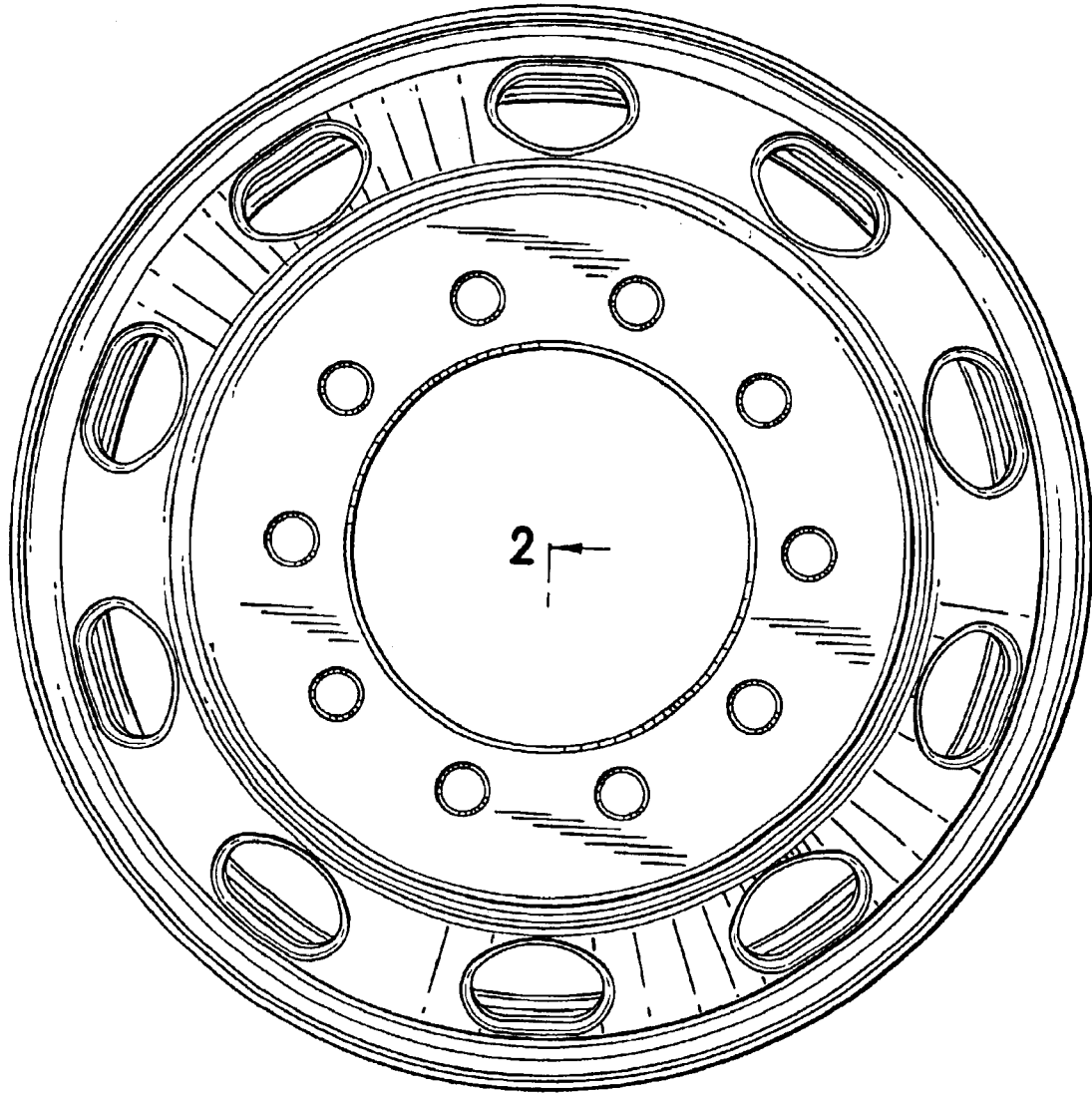

2
FIG. 1

FIG. 2

