



US00D461135S

(12) **United States Design Patent** (10) **Patent No.:** **US D461,135 S**  
**Watson et al.** (45) **Date of Patent:** **\*\* Aug. 6, 2002**

(54) **LASER LEVEL**

(75) Inventors: **James B. Watson**, Fallston; **Daniel N. Lopano**, Towson, both of MD (US)

(73) Assignee: **Black & Decker Inc.**, Newark, DE (US)

(\*\*) Term: **14 Years**

(21) Appl. No.: **29/149,826**

(22) Filed: **Oct. 18, 2001**

(51) **LOC (7) Cl.** ..... **10-04**

(52) **U.S. Cl.** ..... **D10/69; D10/66**

(58) **Field of Search** ..... **D10/66, 69; 33/291, 33/295-299, DIG. 21, 292-294; 356/138, 249, 250, 139-155; 372/9-30**

(56) **References Cited**

**U.S. PATENT DOCUMENTS**

D418,432 S \* 1/2000 Krantz ..... D10/69  
D429,481 S \* 8/2000 Ishii ..... D10/66 X  
6,314,650 B1 \* 11/2001 Falb ..... 33/291

\* cited by examiner

*Primary Examiner*—Antoine Duval Davis  
(74) *Attorney, Agent, or Firm*—Adan Ayala

(57) **CLAIM**

The ornamental design for a laser level, as shown and described.

**DESCRIPTION**

FIG. 1 is a front perspective view from the right side of a first embodiment of a laser level showing our new design.

FIG. 2 is a front elevational view of the first embodiment. FIG. 3 is a rear elevational view of the first embodiment. FIG. 4 is a right side elevational view of the first embodiment. FIG. 5 is a left side elevational view of the first embodiment. FIG. 6 is a top plan view of the first embodiment. FIG. 7 is a bottom plan view of the first embodiment. FIG. 8 is a front perspective view from the right side of a second embodiment of a laser level showing our new design, where the laser level of FIG. 1 is installed in a first position on a support assembly. FIG. 9 is a front elevational view of the second embodiment. FIG. 10 is a rear elevational view of the second embodiment. FIG. 11 is a right side elevational view of the second embodiment. FIG. 12 is a left side elevational view of the second embodiment. FIG. 13 is a top plan view of the second embodiment. FIG. 14 is a bottom plan view of the second embodiment. FIG. 15 is a front perspective view from the left side of a third embodiment of a laser level showing our new design, where the laser level of FIG. 1 is installed in a second position on the support assembly. FIG. 16 is a top plan view of the third embodiment. FIG. 17 is a bottom plan view of the third embodiment. FIG. 18 is a right side elevational view of the third embodiment. FIG. 19 is a left side elevational view of the third embodiment. FIG. 20 is a front elevational view of the third embodiment; and, FIG. 21 is a rear elevational view of the third embodiment. In the above drawings, any wording or numerals shown therein does not form a part of the invention.

**1 Claim, 21 Drawing Sheets**

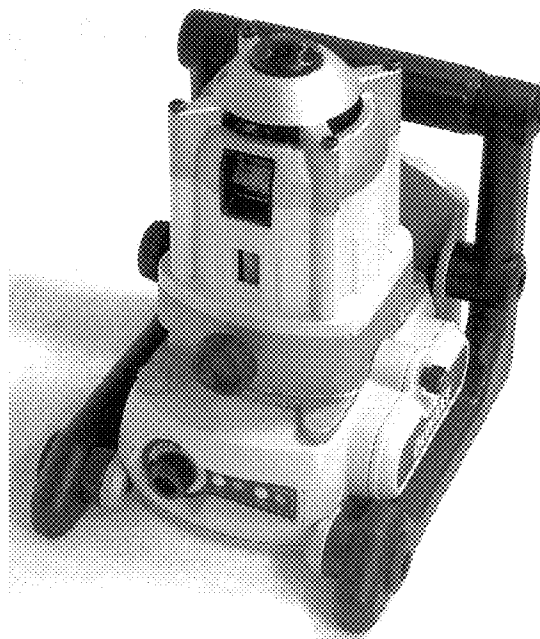



FIG. 1

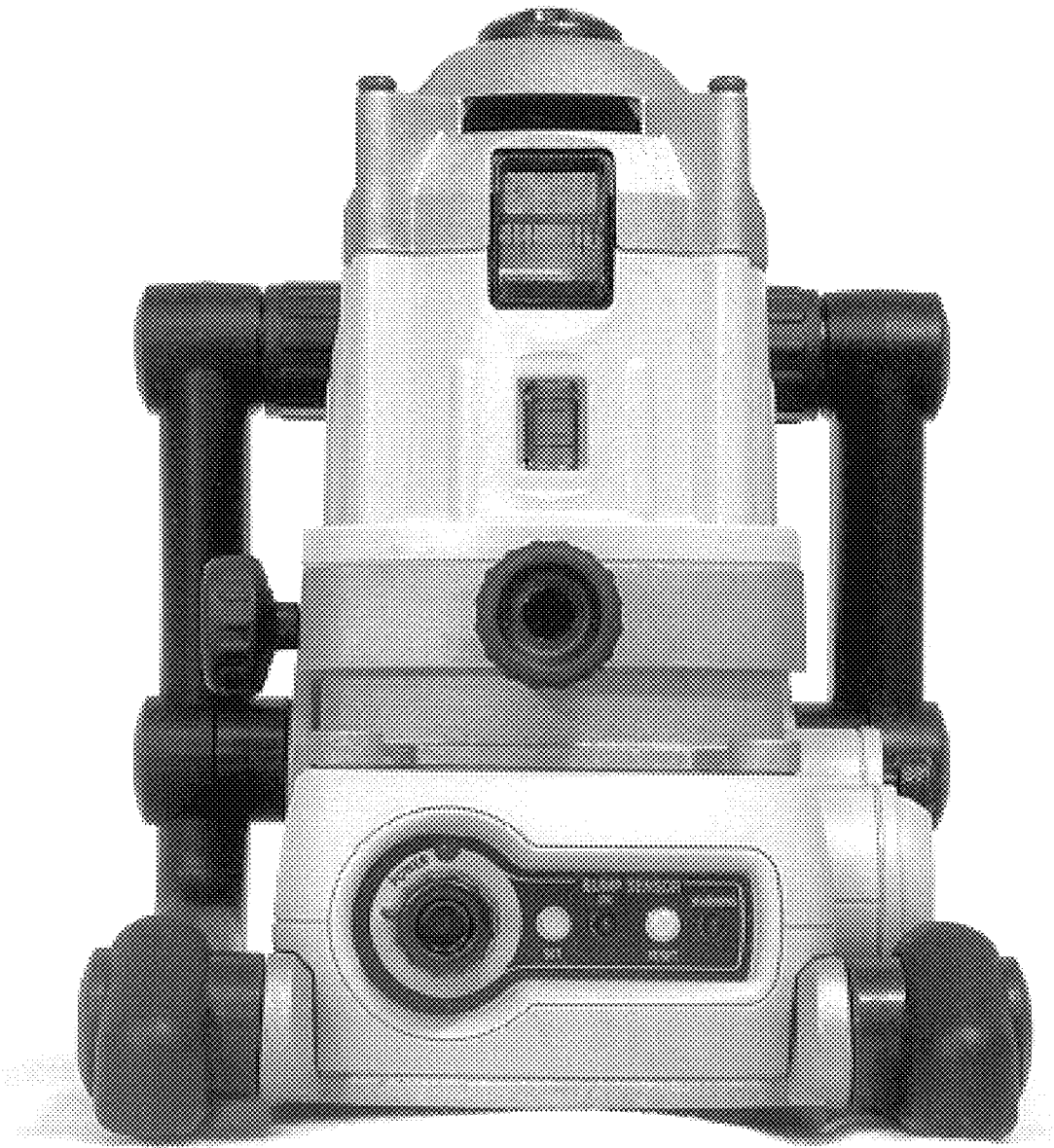

FIG. 2

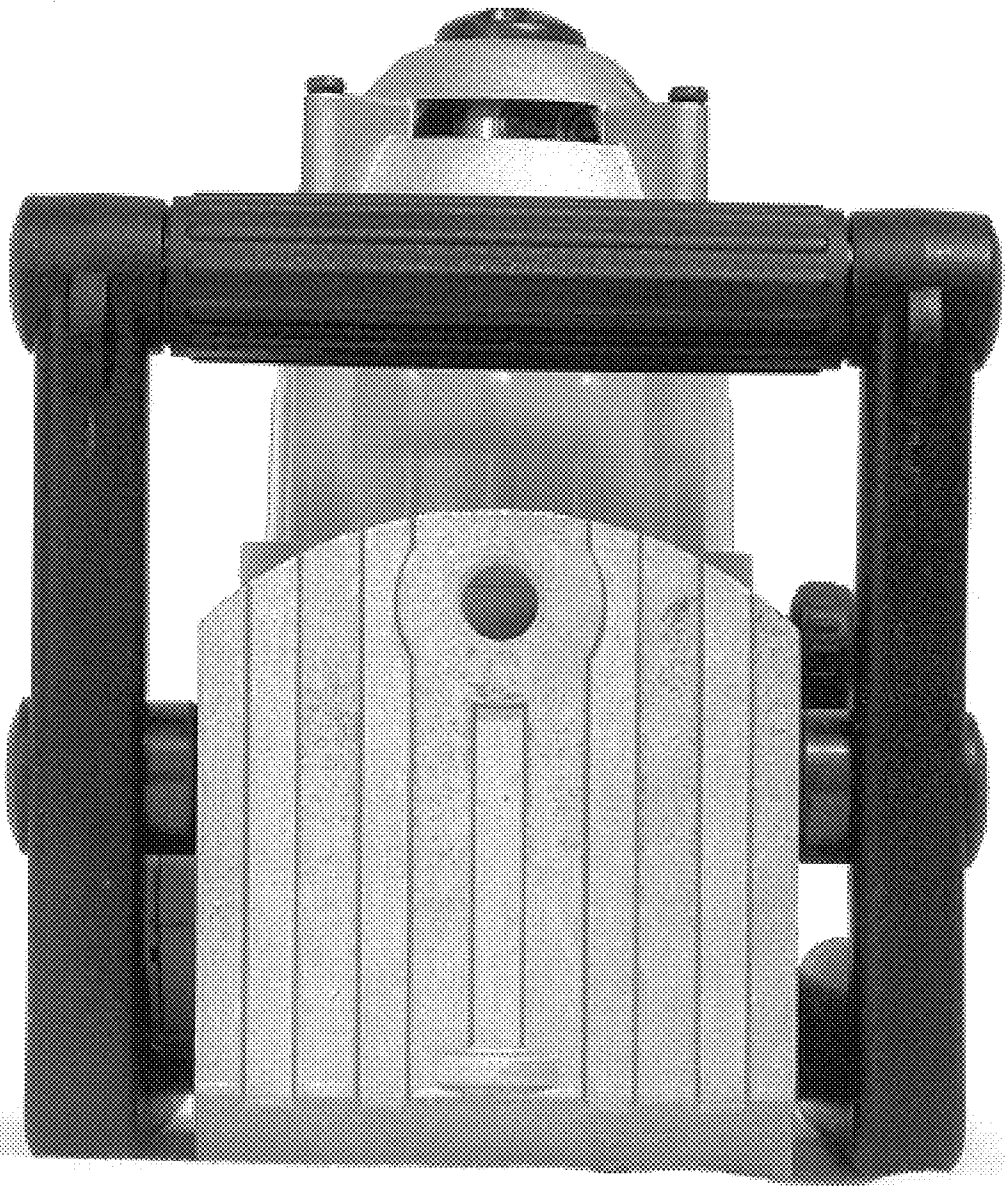

FIG. 3

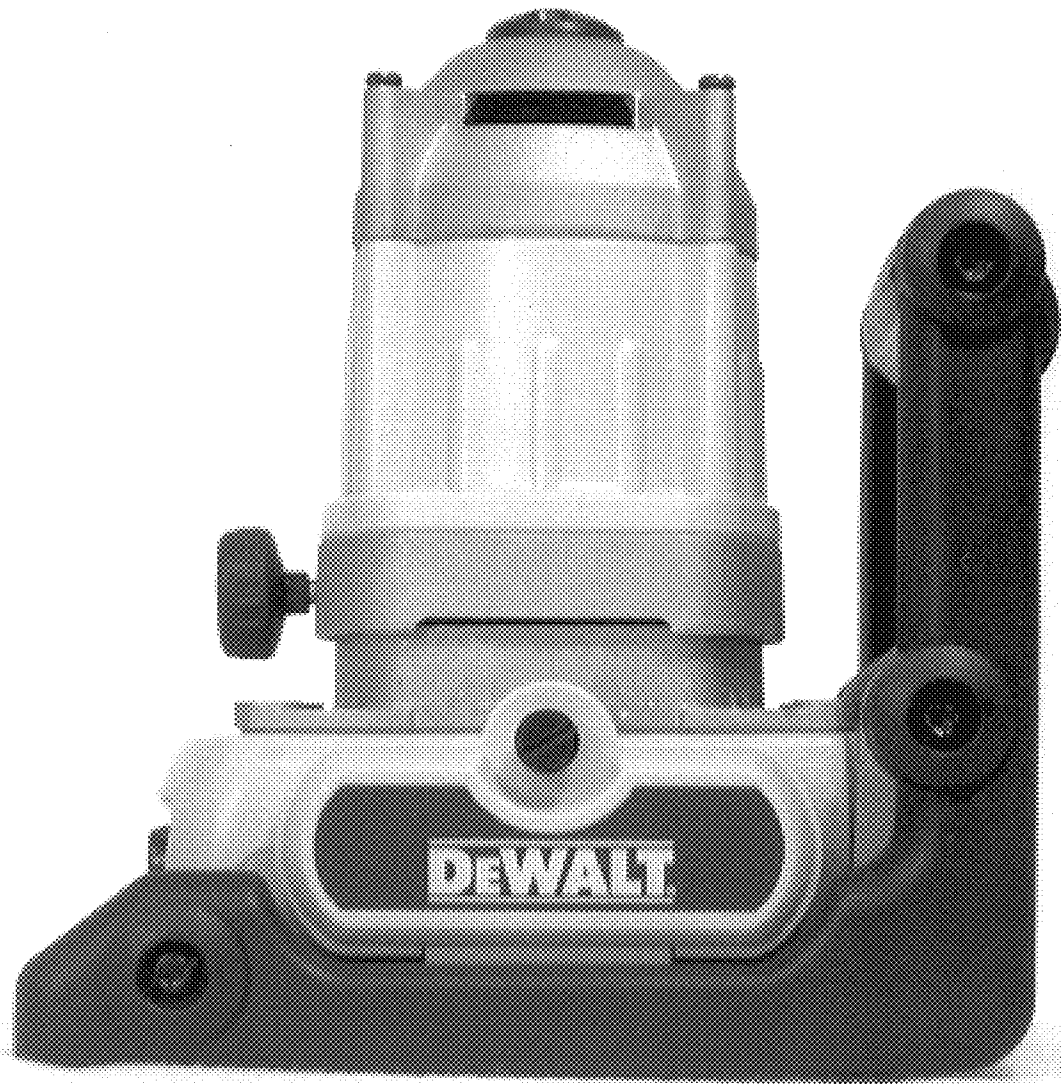

FIG. 4

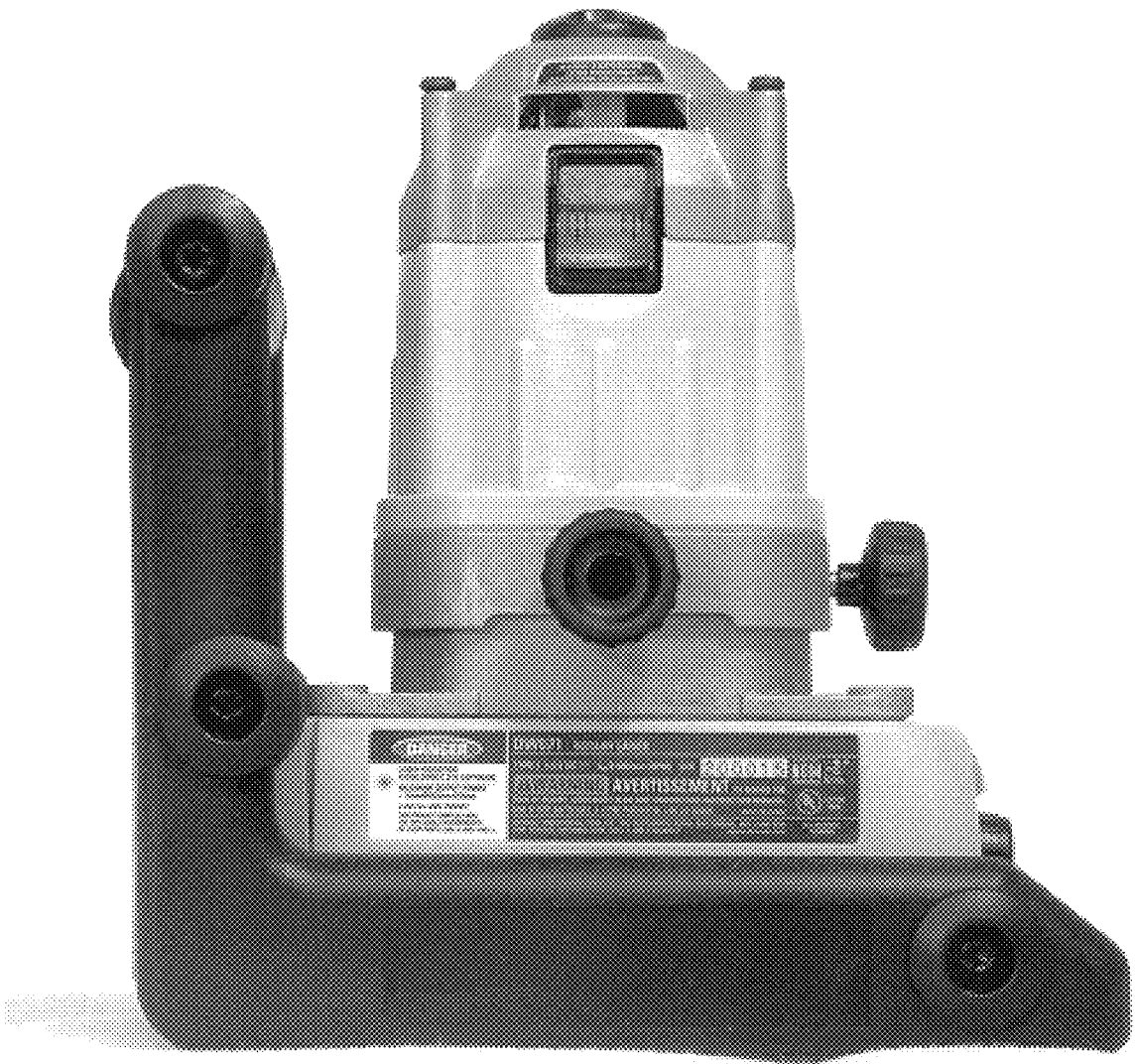

FIG. 5

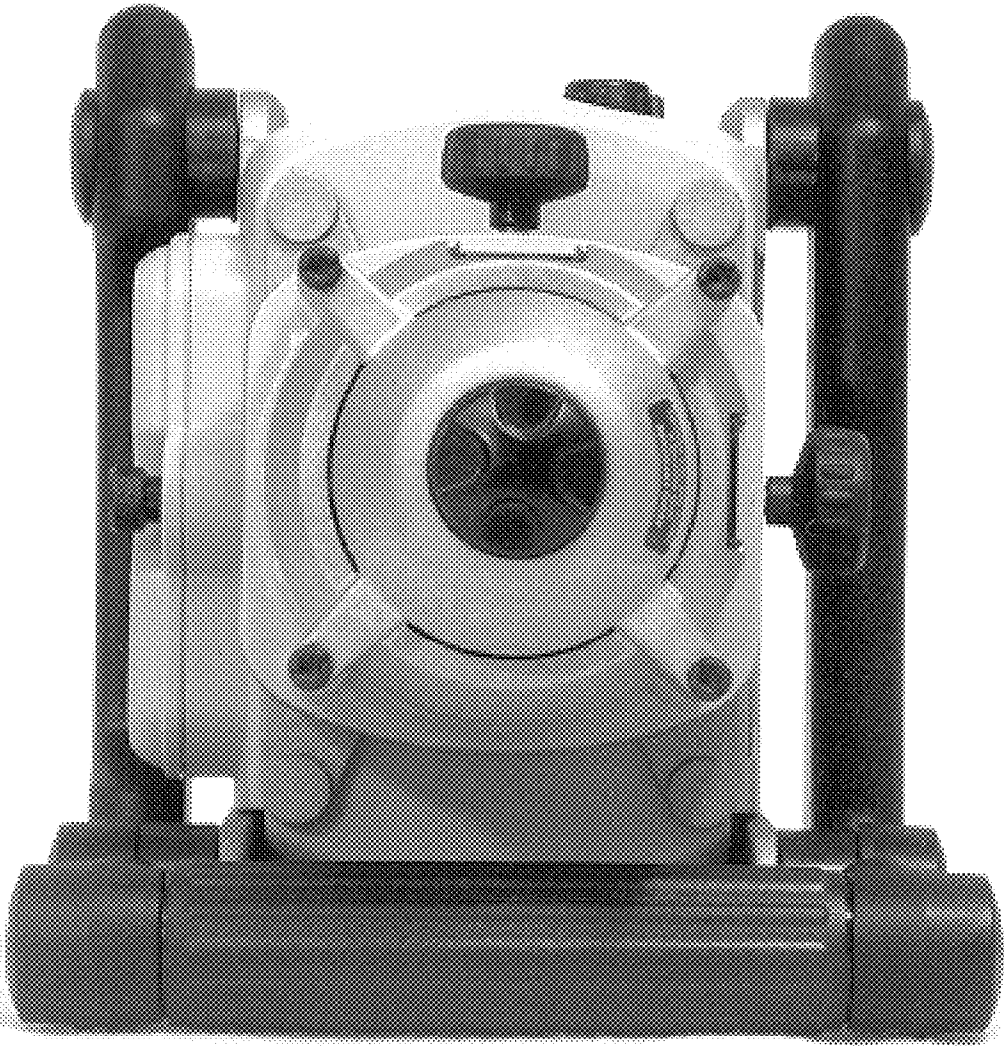

FIG. 6

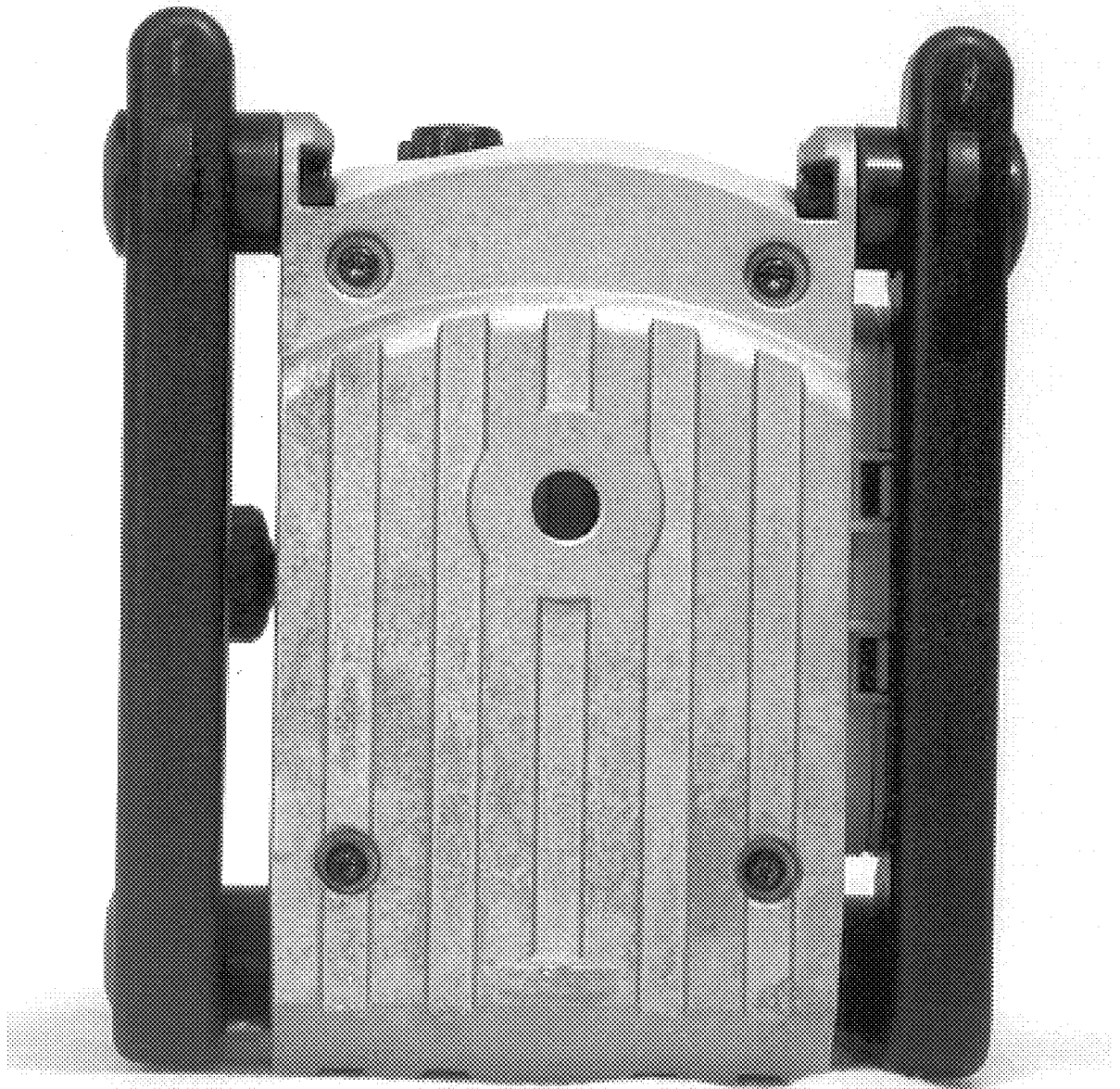

FIG. 7





FIG. 8

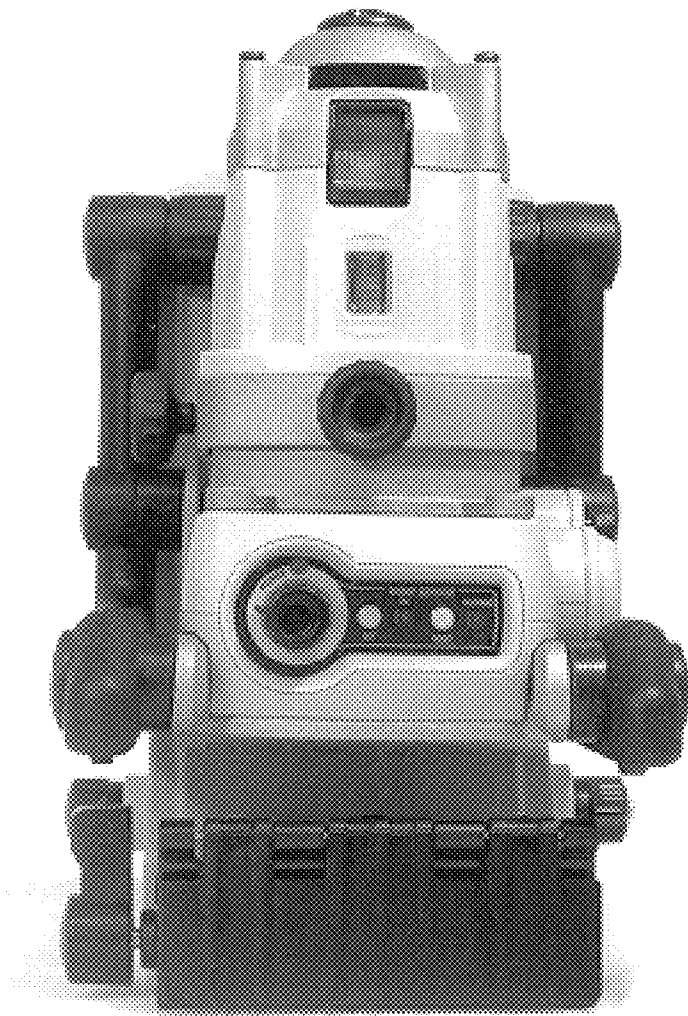

FIG. 9

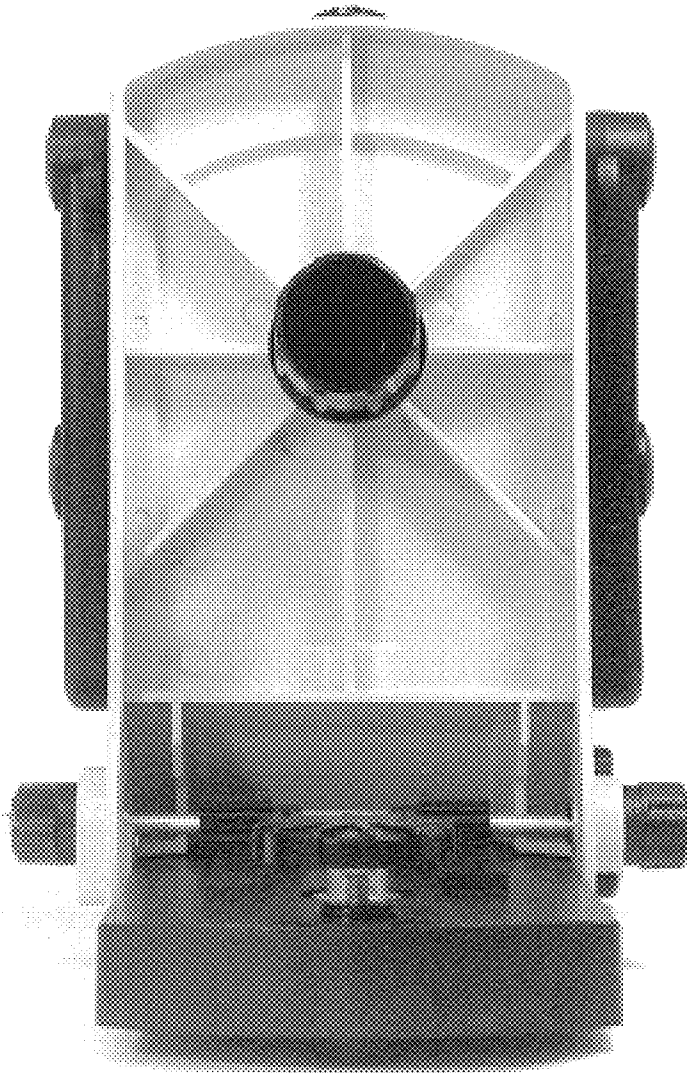

FIG. 10

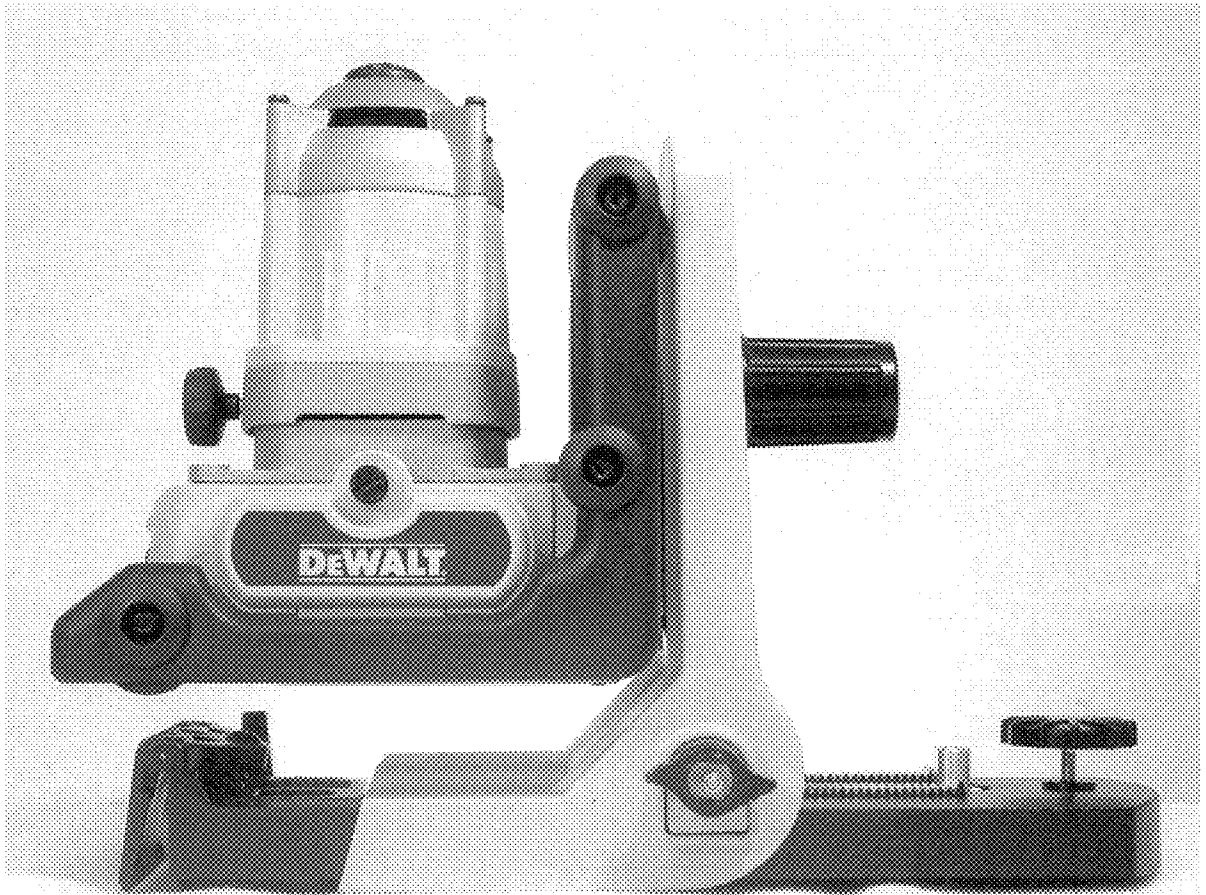

FIG. 11

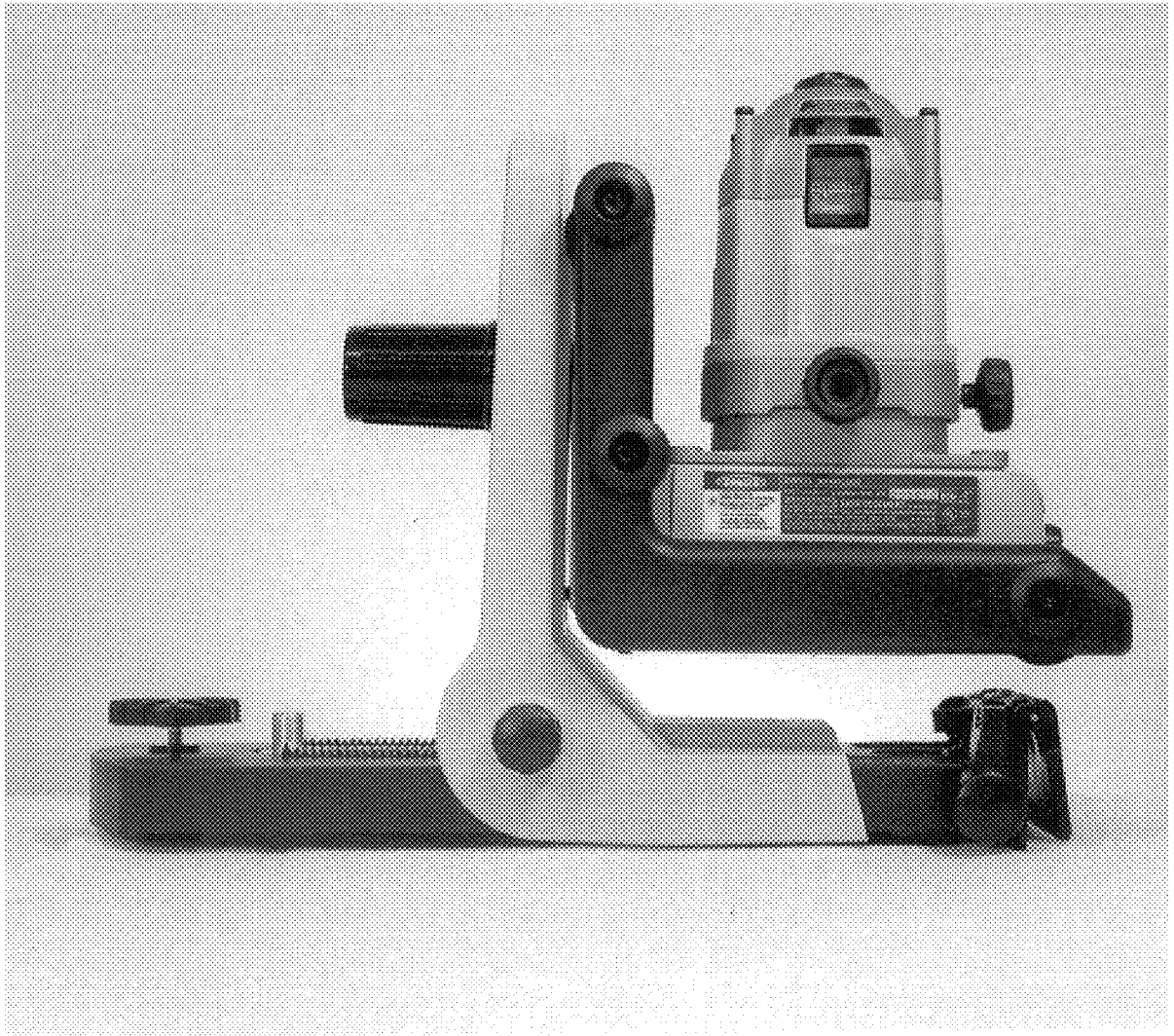

FIG. 12

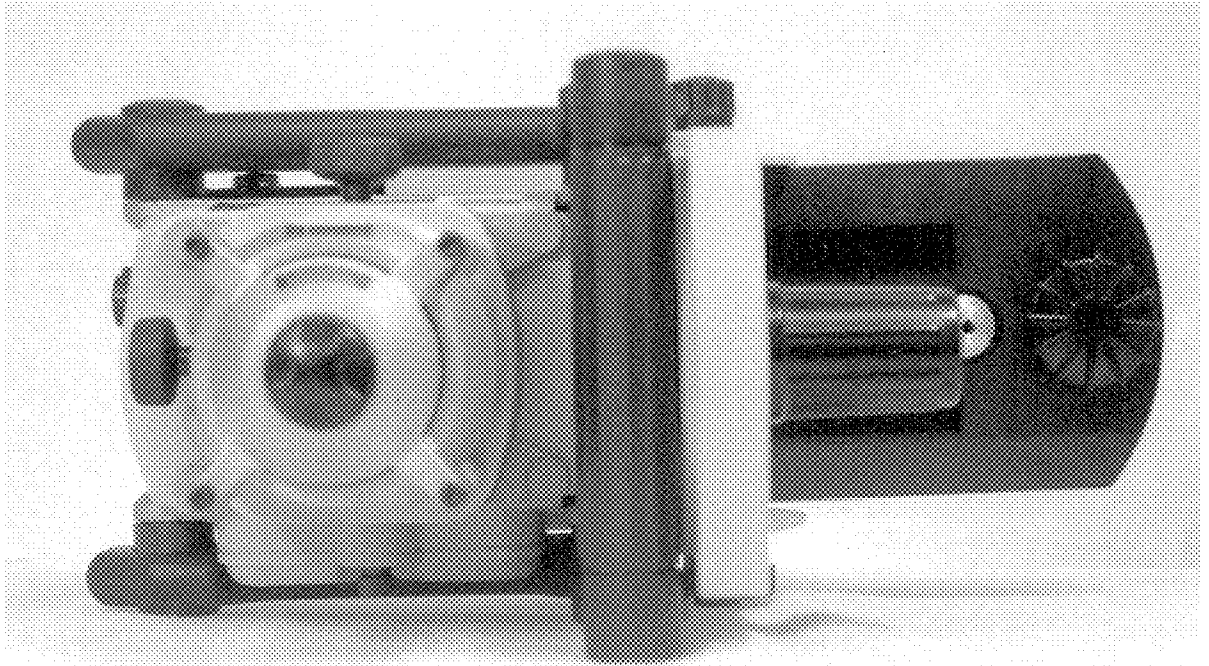

FIG. 13

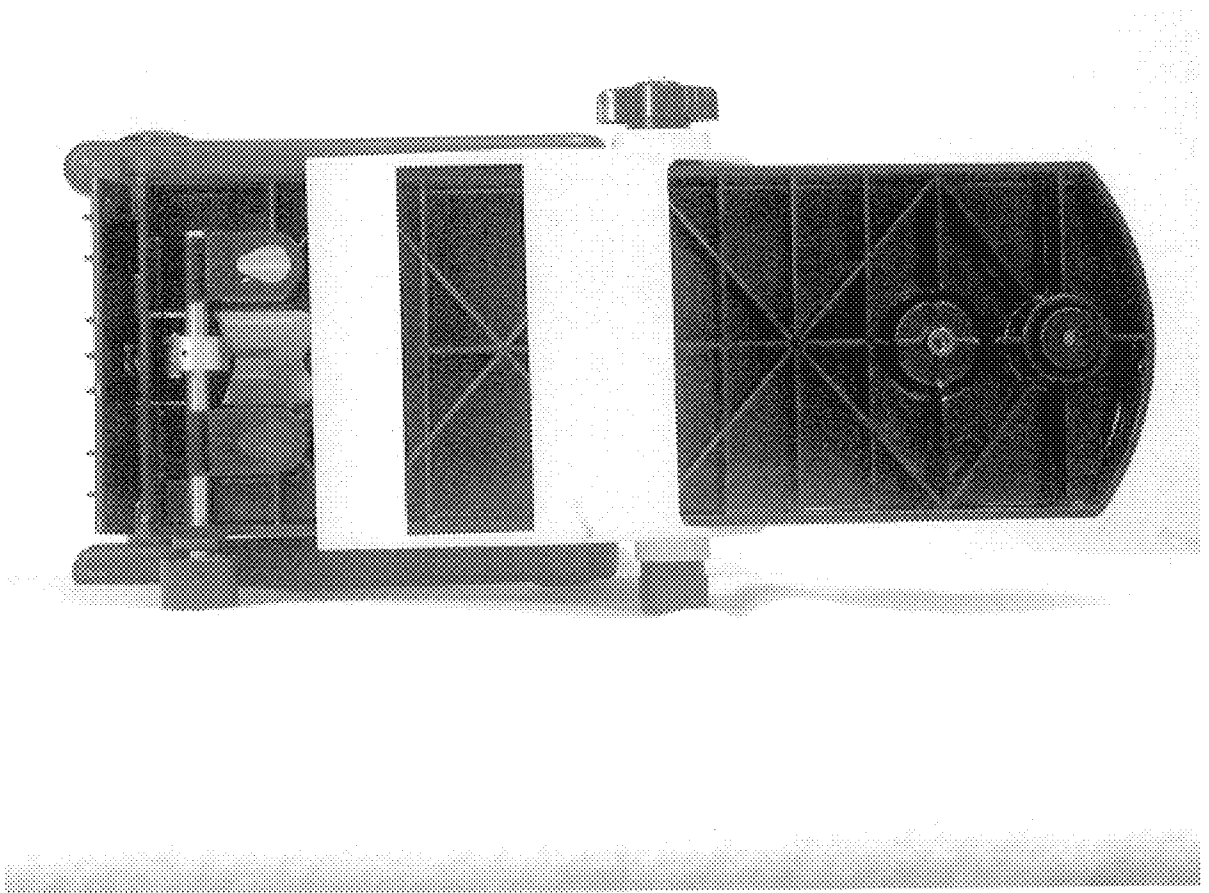

FIG. 14

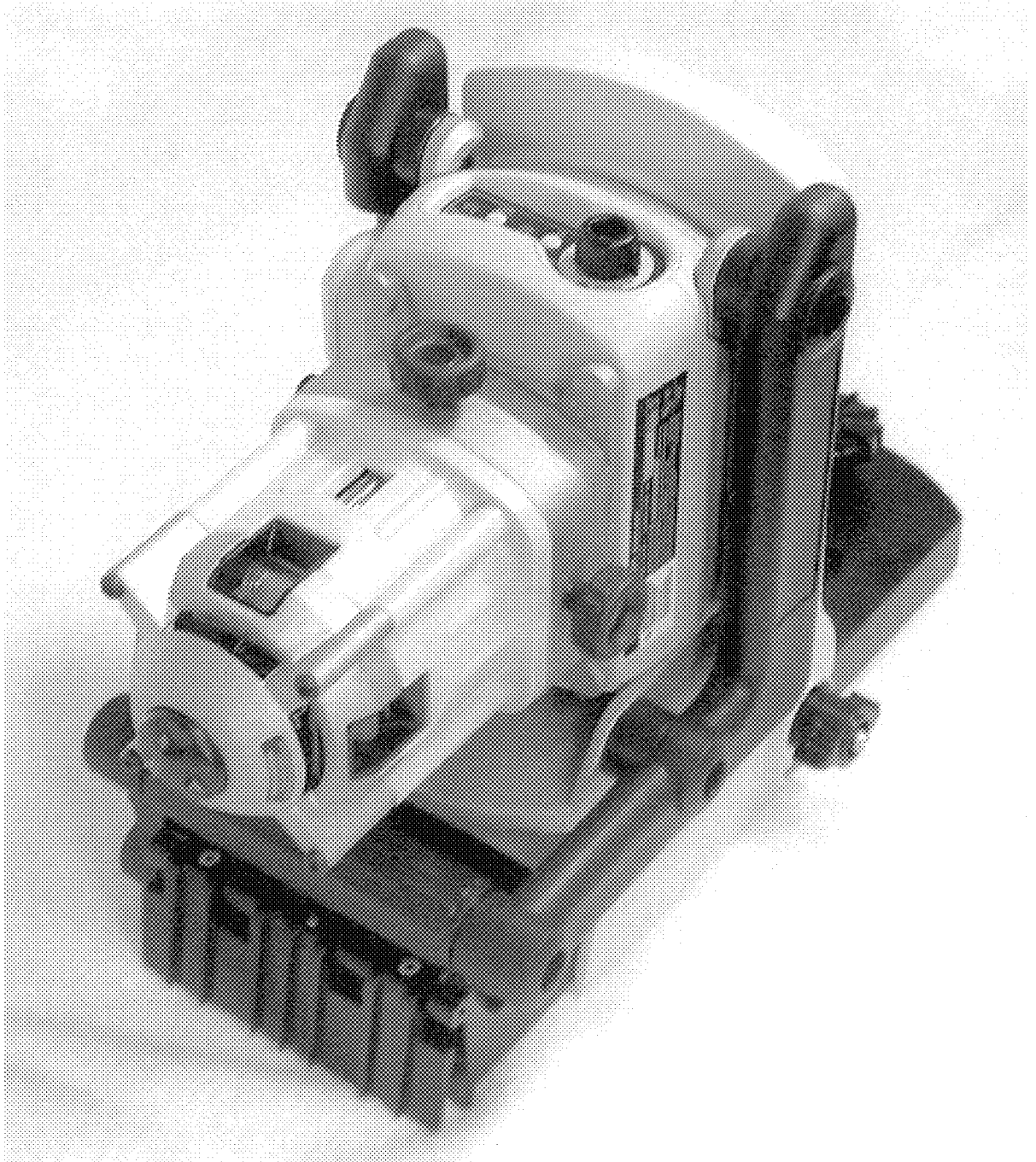

FIG. 15



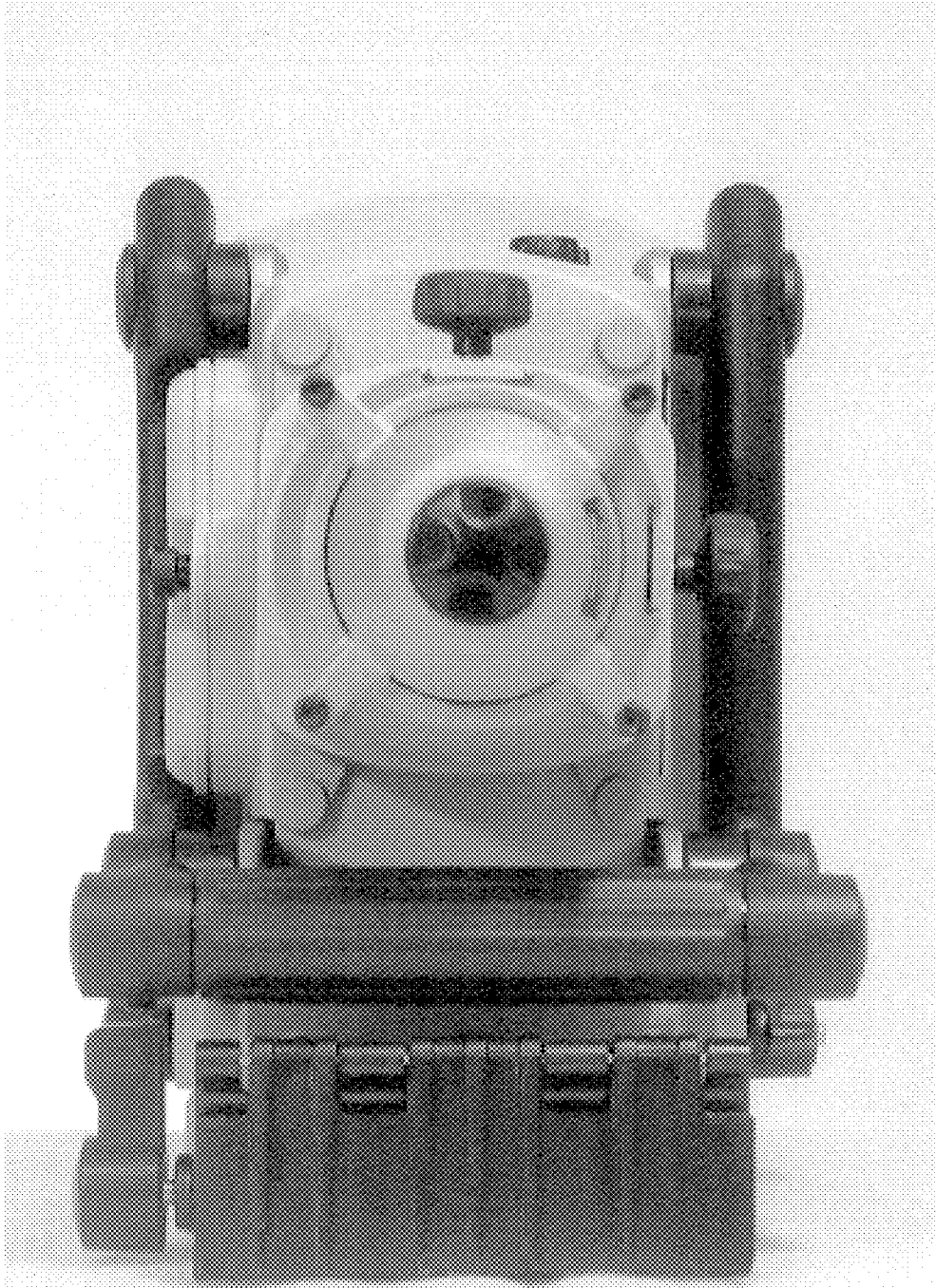

FIG. 16

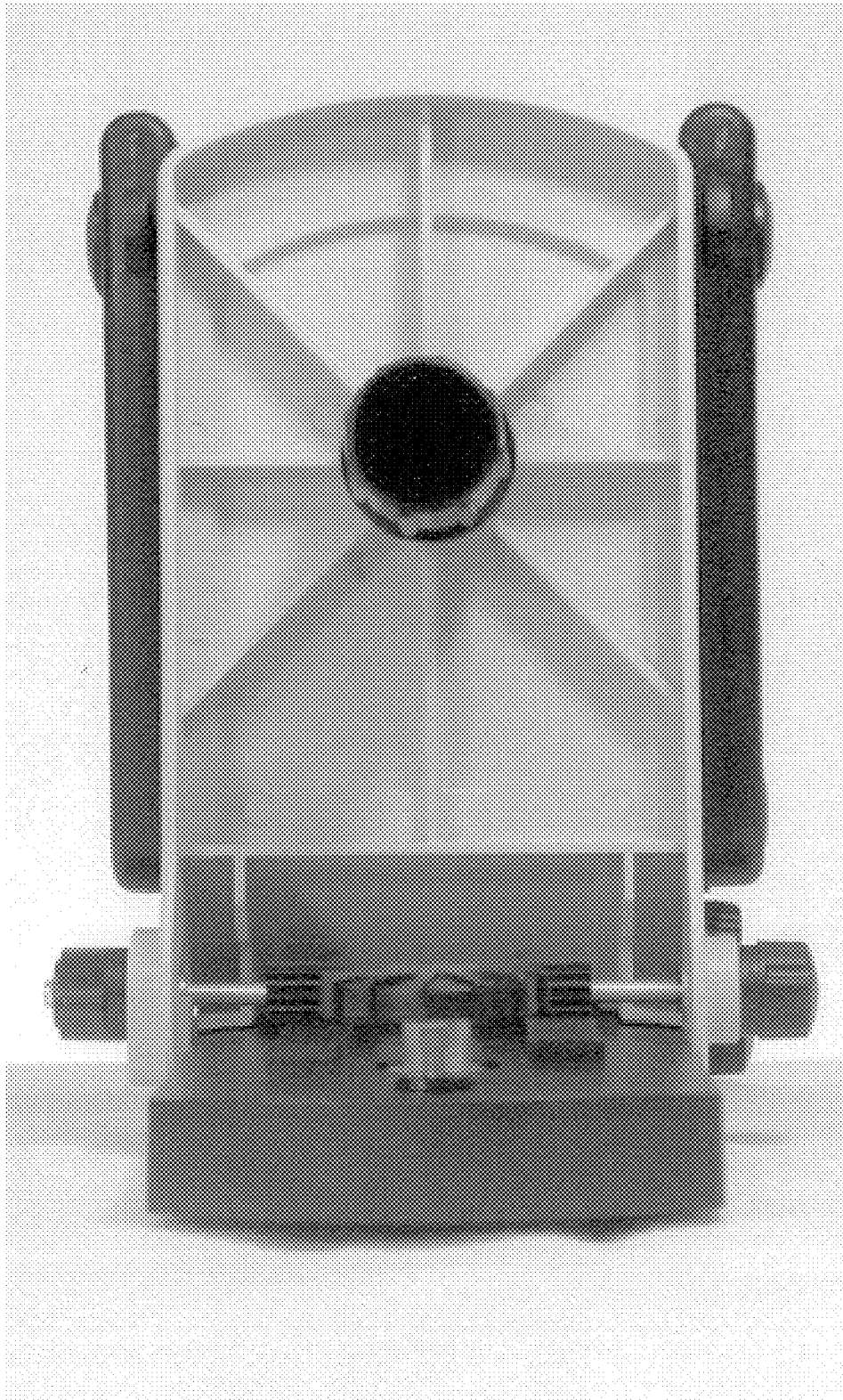

FIG. 17

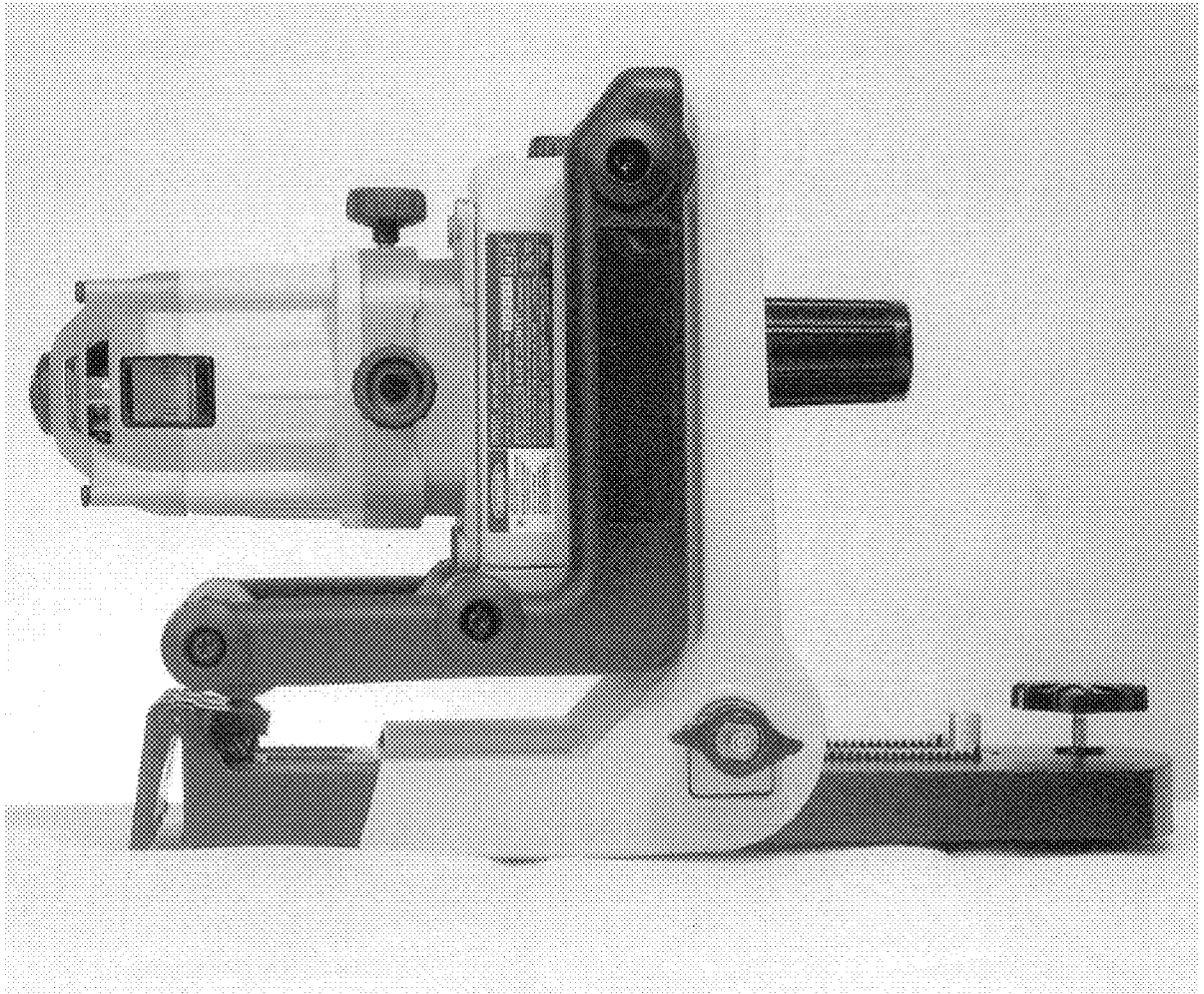

FIG. 18

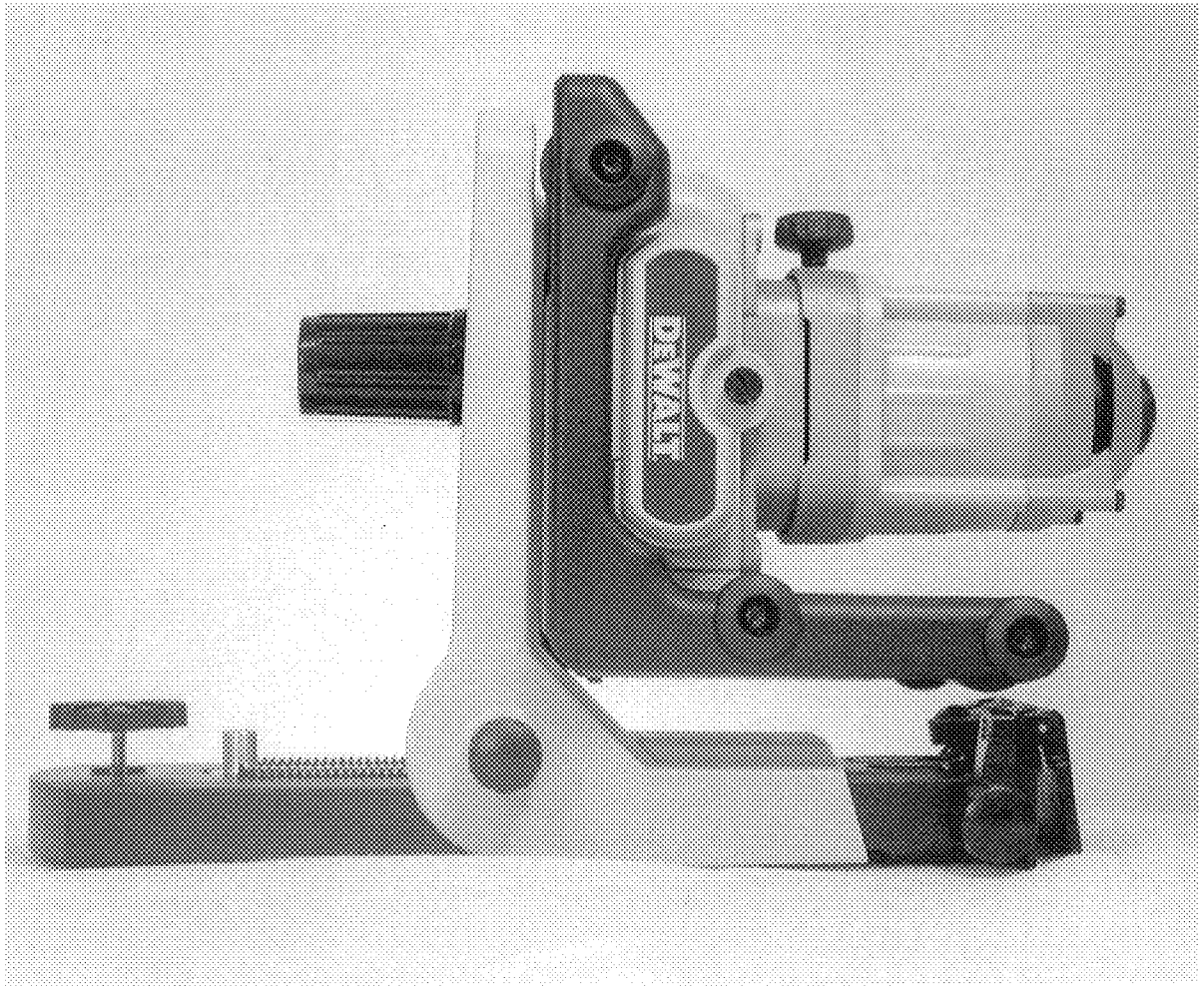

FIG. 19

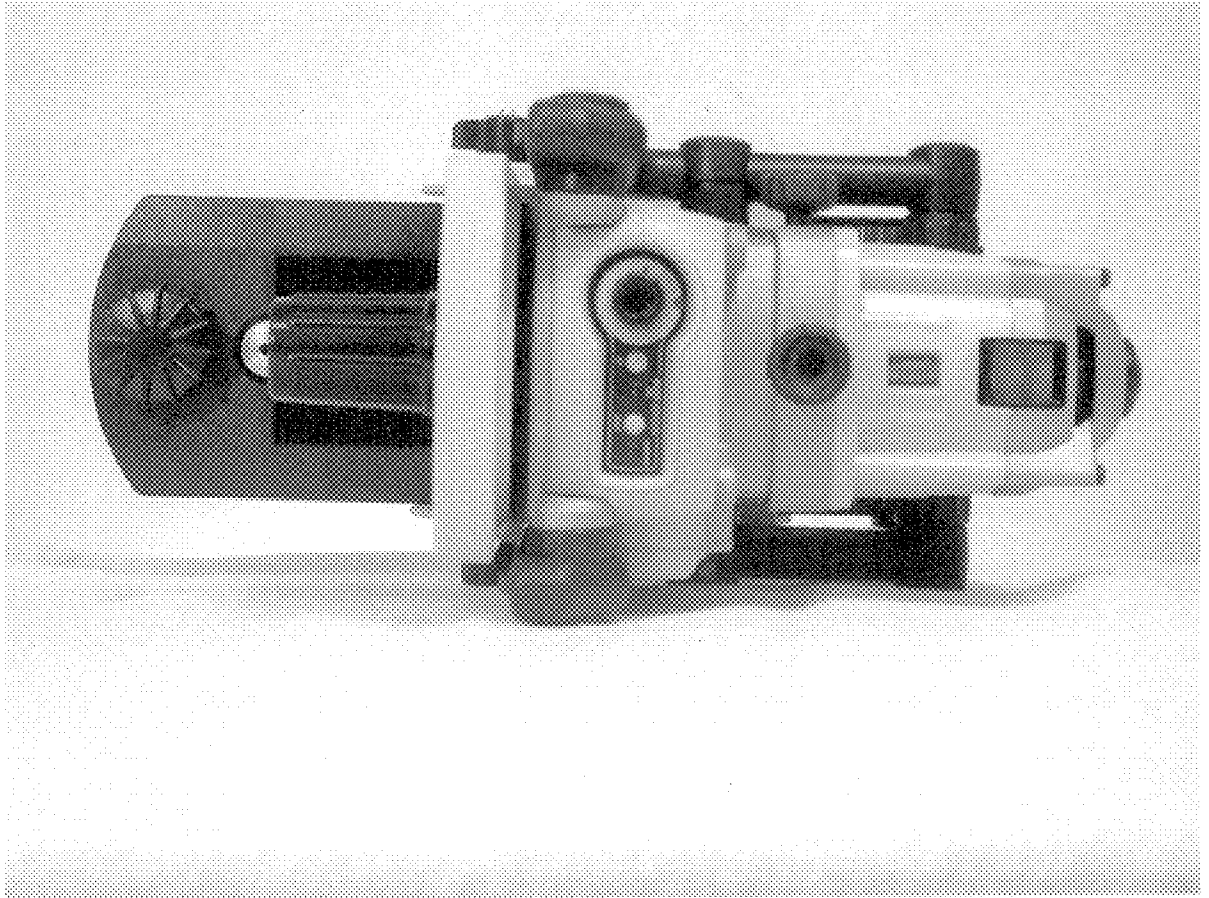

FIG. 20

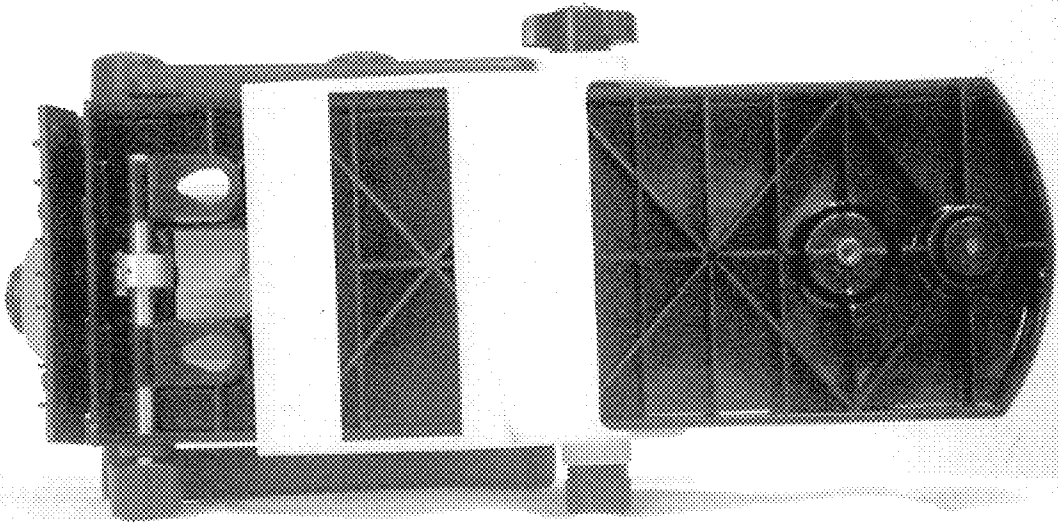

FIG. 21