



(12) **EUROPEAN PATENT APPLICATION**

(43) Date of publication:  
**17.05.2006 Bulletin 2006/20**

(51) Int Cl.:  
**F23G 7/08 (2006.01)**

(21) Application number: **05256432.5**

(22) Date of filing: **17.10.2005**

(84) Designated Contracting States:  
**AT BE BG CH CY CZ DE DK EE ES FI FR GB GR  
HU IE IS IT LI LT LU LV MC NL PL PT RO SE SI  
SK TR**  
Designated Extension States:  
**AL BA HR MK YU**

(72) Inventors:  
• **Wilkins, James  
Tulsa, Oklahoma 74133 (US)**  
• **Poe, Roger L.  
Beggs, Oklahoma 74421 (US)**

(30) Priority: **16.11.2004 US 989665**

(74) Representative: **Roberts, Mark Peter  
J.A. Kemp & Co.,  
14 South Square,  
Gray's Inn  
London WC1R 5JJ (GB)**

(71) Applicant: **JOHN ZINK COMPANY, L.L.C.  
Tulsa, OK 74116 (US)**

(54) **Linear coanda flare apparatus and methods of burning waste flammable gas**

(57) Linear Coanda flare apparatus (18) for burning pressurized waste flammable gas are disclosed. The flare apparatus basically comprises an elongated closed end pipe (20) connected to a waste flammable gas supply pipe (22) and having an elongated linear opening therein (24); and an elongated flammable gas distributor trough (26);

(26) positioned adjacent to the elongated linear opening in the closed end pipe with the sides of the distributor trough being positioned adjacent to the outer curved surfaces of the closed end pipe thereby forming slots (27) that discharge pressurized waste flammable gas from inside the closed end pipe over the outer curved surfaces of the closed end pipe.

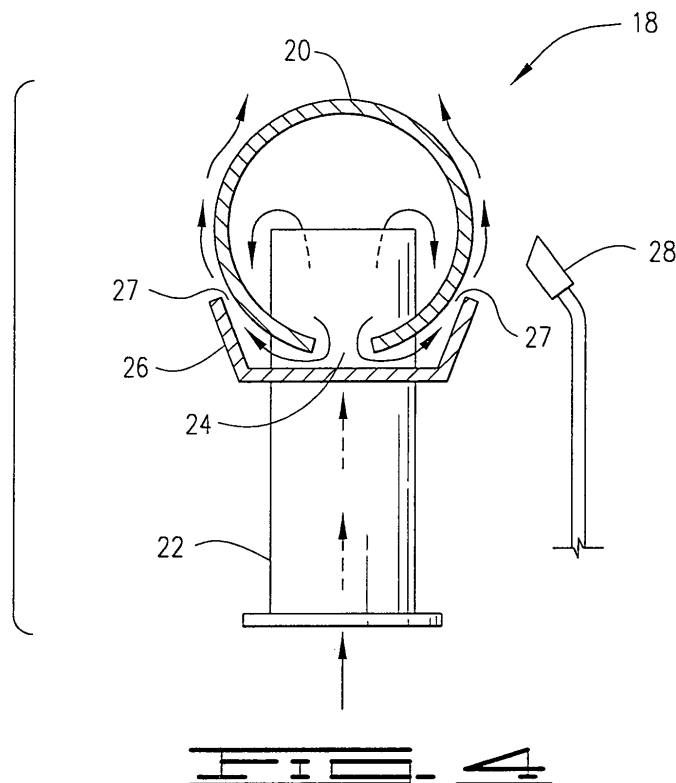

**Description**

## BACKGROUND OF THE INVENTION

## 1. FIELD OF THE INVENTION

**[0001]** The present invention relates to linear Coanda flare apparatus and methods of burning waste flammable gas in the apparatus.

## 2. DESCRIPTION OF THE PRIOR ART

**[0002]** High pressure Coanda flares have been utilized in the oil and gas and petrochemical industries for many years. The flares include a Coanda body having a surface shape similar to a pot that has an enlarged round bottom and a smaller circular top. The Coanda bodies utilized heretofore have been formed from castings or forgings.

**[0003]** The prior art Coanda flares include a Coanda body attached to the top of a vertical pipe whereby a circular slot is formed between the top of the pipe and the bottom of the Coanda body. Pressurized waste flammable gas exits the slot at a velocity that creates low pressure regions at the boundaries of the gas stream. The space between the Coanda body and the gas stream is quickly evacuated by the low pressure which forces the waste gas to attach to the Coanda surface and follow its form until it has turned through approximately 90°.

**[0004]** The normal operating range is at sonic velocity and many small eddies are formed whereby at any point in the gas stream, the velocity is greater than the linear velocity of the overall stream. In addition, the linear velocity is greater than a conventional jet at the same distance from the gas exit. This increases the low pressure region at the film boundary thereby increasing air entrainment efficiency. As the gas and air reach the maximum diameter of the Coanda body surface, the inherent turbulence provides effective mixing of the gas and air thereby producing a very stable and efficient flare device.

**[0005]** When the fuel pressure at the Coanda slot is about 11 psig, the fuel velocity at the slot becomes sonic. The relationship between gas flow rate and Coanda slot exit pressure becomes linear once sonic exit velocity is achieved and the only way to increase capacity is to increase either the gas pressure or the Coanda slot area. As a result, in order to achieve higher capacities, larger diameter flares with larger Coanda bodies, slots and surfaces are required which become very heavy and costly.

**[0006]** In some cases, the waste flammable gas pressure in a Coanda flare is limited by the process involved and by the geometry of the flare. Once a certain pressure is attained, the mass flow achieves a critical level whereby there is such momentum in the gas film passing over the Coanda surface that the flame detaches from the Coanda surface and the Coanda effect is lost.

**[0007]** Thus, there is a need for improved high pressure flares which utilize the Coanda effect, that do not have the disadvantages mentioned above and instead

have the advantages of a robust long life design, low radiation, low weight, high smokeless turndown, wide operating range, low purge rate requirement and a stable flame in all conditions.

## SUMMARY OF THE INVENTION

**[0008]** The present invention provides a linear Coanda flare apparatus for burning pressurized waste flammable gas which overcomes the deficiencies of the prior art and meets the needs described above. A linear Coanda flare apparatus for burning pressurized waste flammable gas of this invention comprises the following elements. An elongated closed end pipe is connected to a waste flammable gas supply pipe. The elongated closed end pipe has an elongated linear opening therein, and an elongated flammable gas distributor trough is positioned adjacent to the elongated linear opening. The sides of the distributor trough are positioned adjacent to the outer curved surfaces of the closed end pipe thereby forming slots that discharge pressurized waste flammable gas over the outer curved surfaces of the closed end pipe.

**[0009]** A method of burning waste flammable gas of this invention comprises the following steps. The waste flammable gas is conducted to a linear Coanda flare apparatus comprising a waste flammable gas supply pipe connected to an elongated closed end pipe having an elongated linear opening therein. The waste flammable gas is discharged through the elongated linear opening into an elongated flammable gas distributor trough positioned adjacent to the elongated linear opening. The elongated sides of the distributor trough are positioned adjacent to the outer curved surfaces of the closed end pipe thereby forming elongated discharge slots. The waste flammable gas is discharged through the elongated discharge slots over the curved surfaces of the closed end pipe. The waste flammable gas is ignited by a pilot light positioned adjacent to the closed end pipe.

**[0010]** The features and advantages of the present invention will be readily apparent to those skilled in the art upon a reading of the description of preferred embodiments which follows when taken in conjunction with the accompanying drawings.

## BRIEF DESCRIPTION OF THE DRAWINGS

**[0011]** FIG. 1 is a side, partly sectional view of a prior art Coanda flare.

**[0012]** FIG. 2 is a cross-sectional view taken along line 2-2 of FIG. 1.

**[0013]** FIG. 3 is a side view of one form of the linear Coanda flare apparatus of the present invention.

**[0014]** FIG. 4 is a cross-sectional view taken along line 4-4 of FIG. 3.

**[0015]** FIG. 5 is a side cutaway view of another form of the linear Coanda flare apparatus of the present invention.

**[0016]** FIG. 6 is a cross-sectional view taken along line

6-6 of FIG. 5 illustrating a spring assembly attached to the bottom of the distributor trough and attached to the closed end pipe.

**[0017]** FIG. 7 is a cross-sectional view similar to FIG. 6, but illustrating a spring assembly attached inside the flare apparatus and attached to the distributor trough.

**[0018]** FIG. 8 is another cross-sectional view similar to FIG. 6, but illustrating the spring assembly attached to the top of the closed end pipe and attached to the distributor trough.

**[0019]** FIG. 9 is a cross-sectional view of a linear Coanda flare apparatus similar to FIG. 4, but illustrating the elongated closed end pipe and the distributor trough positioned at an angle.

**[0020]** FIG. 10 is a side view of a linear Coanda flare apparatus similar to FIG. 5, but illustrating the closed end pipe and distributor trough positioned at an angle.

**[0021]** FIG. 11 is a cross-sectional view of two linear Coanda flare apparatuses positioned close together having elongated closed end pipes formed in tear drop cross-sectional shapes.

**[0022]** FIG. 12 is a side view of a linear Coanda flare apparatus of the present invention including means for injecting water into the gas stream flowing through the elongated closed end pipe.

**[0023]** FIG. 13 is a side view of a linear Coanda flare apparatus of the present invention including means for injecting water into the flame produced by the flare apparatus.

**[0024]** FIG. 14 is a perspective view of a linear Coanda flare apparatus of this invention comprised of a single closed end pipe and distributor connected to a waste flammable gas supply pipe.

**[0025]** FIG. 15 is a perspective view similar to FIG. 14 but including two closed end pipes and distributors attached to a waste flammable gas supply pipe.

**[0026]** FIG. 16 is a perspective view of four elongated closed end pipes and distributors connected to a waste flammable gas supply pipe.

**[0027]** FIG. 17 is a perspective view of six closed end pipes and distributors connected to a waste flammable gas supply pipe.

**[0028]** FIG. 18 is a perspective view of an alternate arrangement of four closed end pipes and distributors connected to a waste flammable gas supply pipe.

#### DESCRIPTION OF PREFERRED EMBODIMENTS

**[0029]** Referring now to the drawings, and particularly to FIGS. 1 and 2, a prior art Coanda flare 10 is illustrated having an upstanding waste flammable gas supply pipe 12 and a Coanda body 14 attached to the top of the supply pipe 12. A circular slot 16 is provided between the top of the pipe 12 and the bottom of the Coanda body 14 through which pressurized waste flammable gas flows at high velocity. The gas follows the Coanda surface until it has turned through approximately 90° thereby producing a very stable and efficient flare device. However, in order

to achieve higher capacities, larger diameter waste flammable gas supply pipes, larger Coanda slots and larger Coanda bodies are required which are heavy and costly.

**[0030]** Referring now to FIGS. 3 and 4, one form of the linear Coanda flare apparatus of the present invention is illustrated and designated by the numeral 18. The linear Coanda flare apparatus 18 comprises an elongated closed end pipe 20 connected to a waste flammable gas supply pipe 22. The top open end of the supply pipe 22 is positioned within the closed end pipe 20, as is shown best in FIG. 4. Elongated linear openings 24 are provided in the bottom of the closed end pipe 20 extending on both sides of the supply pipe 22.

**[0031]** An elongated flammable gas distributor trough 26 is attached to the bottom of the elongated closed end pipe 20 adjacent to the linear opening 24. The elongated sides of the distributor trough 26 are positioned adjacent to the outer curved surfaces of the closed end pipe 20 thereby forming slots 27 that discharge pressurized waste flammable gas from inside the closed end pipe 20 over the outer curved surfaces of the closed end pipe 20. The pressurized waste flammable gas attaches to the pipe surface and follows its form until it has turned through approximately 90°. The gas is ignited by a pilot light 28 positioned adjacent to the closed end pipe.

**[0032]** The linear Coanda flare apparatus 18 described above has the following advantages. The closed end pipe 20 and waste flammable gas supply pipe 22 are formed of light weight steel and no special high cost castings or forgings are required thereby reducing costs and weight. The capacity of the linear Coanda flare apparatus 18 can be increased simply by extending the lengths of the closed end pipe 20, the linear openings 24 and the distributor trough 26.

**[0033]** The performance of the linear Coanda flare apparatus of this invention is enhanced by maintaining narrow slots between the sides of the distributor trough 26 and the closed end pipe 20 which improve air entrainment, mixing and maximum operating pressure. The waste flammable gas fed through the supply pipe 22 flows through the closed end pipe 20 thereby providing cooling to the flare apparatus 18. The path of the waste flammable gas restricts the ability of air to enter the flare apparatus 18 thereby mitigating the risk of internal burning and reducing purge gas requirements. The waste flammable gas supply pipe 22 can be arranged centrally as shown in the drawings or at either end of the elongated closed end pipe 20 or at any location in between. The elongated flammable gas distributor trough 26 which forms the fuel exit slots 27 can be of various shapes including, but not limited to, a flat bottom trough with outwardly slanted sides, a semi-circular trough, a partial circular trough, a V-shaped trough and the like. The gas distributor trough can be arranged to be fixed in one position or it can be spring loaded to form variable fuel exit slots which open without increasing pressure to a set maximum as will be described further herein below.

**[0034]** The linear Coanda flare apparatus 18 can be

arranged to fire at an angle by rotating the closed end pipe containing the elongated linear openings 24 and the elongated flammable gas distributor trough 26. In many cases, radiation and noise must be reduced in sensitive areas adjacent to flares or due to space requirements. That is, the flares must be moved or angled to a particular direction. Referring to FIGS. 4, 5, 9 and 10, this can be accomplished in a horizontal flare 18 or 30 of this invention by simply rotating the elongated closed end pipes 20 or 32 and distributor troughs 26 or 38 to an angle whereby the flame is directed away from the sensitive area as shown in FIG. 9. When required, the elongated closed end pipe 32 can also be moved upright as shown in FIG. 10.

**[0035]** Referring now to FIGS. 5-8, an alternate arrangement of the linear Coanda flare apparatus of this invention is illustrated and generally designated by the numeral 30. The linear Coanda flare apparatus 30 comprises a closed end pipe 32 having an elongated linear opening or a series of linear openings 34 in the bottom thereof. A waste flammable gas supply pipe 36 is connected to one end of the closed end pipe 32 by welding or other means. An elongated waste flammable gas distributor trough 38 is provided adjacent to the elongated linear opening or openings 34 at the bottom of the closed end pipe 32. The distributor trough 38 is held in position below the linear opening or openings 34 by spring assemblies 40 attached to the bottom of the flammable gas distributor trough 38 and to the closed end pipe 32 by elongated bolts or rods 42. In addition, spring loaded seal plate assemblies 45 are attached to the elongated closed end pipe 32 which exert pressure on the ends of the distributor trough 38 to prevent waste flammable gas from escaping through the ends of the distributor trough 38. A pilot light 41 is provided to ignite the discharged waste flammable gas.

**[0036]** In operation of the linear Coanda flare apparatus 30, waste flammable gas enters the apparatus 30 by way of the waste flammable gas supply pipe 36 and flows into the elongated closed end pipe 32. From the closed end pipe 32, the gas passes through the slot or slots 34 into the elongated flammable gas distributor trough 38. From the distributor trough 38, the gas flows through the side slots 43 formed between the sides of distributor trough 38 and the closed end pipe 32 and then adjacent to the curved surfaces of the closed end pipe 32 where it entrains and mixes with ambient air in proportions to create a smokeless and low radiation flame.

**[0037]** As the gas flows through the elongated flammable gas distributor trough 38, it applies or reduces pressure on the distributor trough 38 which in turn applies or reduces load on the spring assemblies 40 thereby compressing or decompressing the springs in the spring assemblies 40 and moving the distributor trough 38 away from or closer to the closed end pipe 32. The movement away from or closer to the closed end pipe 32 increases or decreases the widths of the gas exit slots 43 between the closed end pipe 32 and the distributor trough 38 there-

by allowing greater or lesser gas flow onto the surface of the closed end pipe 32.

**[0038]** The variation in the width of the slots 43 not only regulates gas flow and pressure, it also serves to continuously maintain a high velocity at the gas slots which in turn restricts the amount of air that can ingress into the distributor trough by high wind pressure. A narrow slot at low gas flows and pressure causes even distribution of gas along the slot thereby ensuring localized burning and preventing hot spots.

**[0039]** Referring now to FIG. 6, an enlarged side view of the closed end pipe 32, the distributor trough 38 and the spring assembly 40 is shown. The spring assembly 40 includes an elongated threaded rod 42 that is attached to and passes through and below the closed end pipe 32 and the distributor trough 38. A spring 47 is disposed between the bottom of the distributor trough 38 and a moveable circular plate 44 held in position by a nut 46 threaded on the rod 42. The nut 46 can be moved up or down to adjust the compression of the spring 47. A second circular plate 48 is disposed on the rod 42 and a second nut 50 is disposed on the threaded rod 42 below the plate 48. The second nut 50 is utilized to adjust the distance between the bottom of the closed end pipe 32 and the sides of the distributor trough 38, i.e., the slots 43.

**[0040]** FIG. 7 illustrates an alternate arrangement wherein the spring assembly 52 is mounted within the closed end pipe 32 and is used to adjust the position of the distributor trough 38.

**[0041]** FIG. 8 illustrates another spring assembly arrangement wherein a spring assembly 54 is mounted on top of the closed end pipe 32 and is used to adjust the spring tension and location of the distributor trough 38.

**[0042]** While all of the spring assembly arrangements illustrated in FIGS. 6, 7 and 8 can be utilized, the spring arrangement illustrated in FIG. 7 is generally preferred for the reason that the spring assembly located within the closed end pipe is cooled by the flow of the cool flammable gas flowing through the pipe and is out of the flame zone at all times. As will be understood by those skilled in the art, a variety of spring assembly arrangements can be utilized other than those described above.

**[0043]** In many refinery and other industrial plants, flare systems are required that must handle large ranges of gas compositions and capacities which require multiple staged flares and systems. The multiple flares and systems require costly piping and valves that switch on and off the multiple flares to insure maximum performance over the operating range of the flares.

**[0044]** The linear Coanda flare apparatus of the present invention can include multiple or elongated pipes connected to a waste flammable gas supply pipe. The multiple or elongated pipes can have multiple linear openings therein and multiple gas distributor troughs having spring assemblies set to operate at different pressures. As the gas pressure increases, the various gas distributor troughs open in sequence. This ensures that each part of the flare apparatus operates above its critical

pressure at all flow rates thereby ensuring optimum performance at all times.

**[0045]** As illustrated in the drawings, the linear Coanda flare apparatus of this invention utilizes ordinary cylindrical pipe as the elongated closed end pipe having elongated linear openings therein. The pressurized waste flammable gas discharged through the slots formed by the cylindrical pipe and the sides of the distributor trough flows over the outer curved surfaces of the closed end pipe and follows the curved surfaces until it has turned through approximately 90 degrees, i.e., the curved surfaces of the closed end pipe bring about the "Coanda effect." The cylindrical pipe is inexpensive as compared to the Coanda bodies used heretofore and the pipe can be utilized in any desired flare length or position.

**[0046]** Referring now to FIG. 11, in certain applications such as when two or more linear Coanda flare apparatus are located very close together, aerodynamic shaped closed end pipes 56 can be utilized to provide better air distribution and flare performance. When required, other shapes of closed end pipes can also be used. However, the use of cylindrical closed end pipes is preferred.

**[0047]** The introduction of water into the waste gas stream or into the flame produced by a flare apparatus of this invention is some times required to reduce noise and/or radiation. As shown in FIG. 12, the water can be introduced into the closed end pipe to reduce noise, and as shown in FIG. 13, the water can be introduced into the flame above the closed end pipe to reduce radiation.

**[0048]** Referring now to FIGS. 14-18, various arrangements of the linear Coanda flare apparatus of this invention connected to waste gas supply pipes are illustrated. As shown, up to six or more closed end pipes 32 can be connected to a single waste flammable gas supply pipe.

**[0049]** In ground flare applications, the linear Coanda flare apparatus of this invention is ideal in that it can be as long as 40 to 50 feet in one continuous run of a relatively small diameter with the fuel being fed from one end instead of from the bottom.

**[0050]** Regardless of the particular application in which the linear Coanda flare apparatus of this invention is utilized, the flare apparatus will produce a very large heat release from a relatively small flare tip.

**[0051]** A preferred linear Coanda flare apparatus of this invention for burning pressurized waste flammable gas comprises: an elongated closed end pipe connected to a waste flammable gas supply pipe, the elongated closed end pipe having an elongated linear opening therein; and an elongated flammable gas distributor trough positioned adjacent to the elongated linear opening in the closed end pipe with the sides of the distributor trough positioned adjacent to the outer curved surfaces of the closed end pipe thereby forming slots that discharge pressurized waste flammable gas from inside the closed end pipe over the outer curved surfaces of the closed end pipe.

**[0052]** A preferred method of burning waste flammable gas of this invention comprises the steps of: (a) conduct-

ing the waste flammable gas to a Coanda flare apparatus comprising a waste flammable gas supply pipe connected to an elongated closed end pipe having an elongated linear opening therein; (b) discharging the waste flammable gas through the elongated linear opening into an elongated flammable gas distributor trough positioned adjacent to the elongated linear opening, the elongated sides of the distributor trough being positioned adjacent to the outer curved surfaces of the closed end pipe thereby forming elongated discharge slots; (c) discharging the waste flammable gas through the elongated discharge slots over the curved surfaces of the closed end pipe; and (d) igniting the waste flammable gas.

**[0053]** Thus, the present invention is well adapted to carry out the objects and attain the ends and advantages mentioned as well as those inherent therein. While presently preferred embodiments of the invention have been described for purposes of this disclosure, numerous changes in the arrangement and construction of parts will suggest themselves to those skilled in the art, which changes are encompassed within the spirit of this invention as defined by the appended claims.

## Claims

1. A linear Coanda flare apparatus for burning pressurized waste flammable gas comprising:
  - an elongated closed end pipe connected to a waste flammable gas supply pipe, the elongated closed end pipe having an elongated linear opening therein; and
  - an elongated flammable gas distributor trough positioned adjacent to the elongated linear opening in the closed end pipe with the sides of the distributor trough being positioned adjacent to the outer curved surfaces of the closed end pipe thereby forming slots that discharge pressurized waste flammable gas from inside the closed end pipe over the outer curved surfaces of the closed end pipe.
2. The flare apparatus of claim 1 which further comprises means for igniting the flammable gas.
3. The flare apparatus of claim 1 or 2, which further comprises a pilot light for igniting the flammable gas.
4. The flare apparatus of claim 1, 2 or 3, wherein the elongated closed end pipe and distributor trough are positioned substantially horizontally.
5. The flare apparatus of claim 1, 2 or 3, wherein the elongated closed end pipe and distributor trough are positioned at an angle.
6. The flare apparatus of any one of the preceding

- claims, wherein two or more elongated closed end pipes with distributor troughs are connected to the waste flammable gas supply pipe.
7. The flare apparatus of any one of the preceding claims, wherein the flammable gas distributor trough is attached to the closed end pipe by one or more spring assemblies so that the slots that discharge waste flammable gas increase or decrease in width when the pressure of the waste flammable gas increases or decreases.
8. The flare apparatus of claim 7 wherein the spring assemblies are attached to the bottom of the flammable gas distributor trough and to the closed end pipe.
9. The flare apparatus of claim 7 wherein the spring assemblies are attached to the inside of the closed end pipe and to the flammable gas distributor trough.
10. The flare apparatus of claim 7 wherein the spring assemblies are attached to the top of the closed end pipe and to the flammable gas distributor trough.
11. The flare apparatus of any one of claims 7 to 10, which further comprises additional spring assemblies attached to the closed end pipe that exert pressure on the ends of the elongated flammable gas distributor trough to thereby prevent loss of the pressurized waste flammable gas through the ends of the distributor trough.
12. A method of burning waste flammable gas comprising the steps of:
- (a) conducting the waste flammable gas to a Coanda flare apparatus comprising a waste flammable gas supply pipe connected to an elongated closed end pipe having an elongated linear opening therein;
  - (b) discharging the waste flammable gas through the elongated linear opening into an elongated flammable gas distributor trough positioned adjacent to the elongated linear opening, the elongated sides of the distributor trough being positioned adjacent to the outer curved surfaces of the closed end pipe thereby forming elongated discharge slots;
  - (c) discharging the waste flammable gas through the elongated discharge slots over the curved surfaces of the closed end pipe; and
  - (d) igniting the waste flammable gas.
13. The method of claim 12 wherein the elongated closed end pipe and the elongated flammable gas distributor trough are positioned substantially horizontally.
14. The method of claim 12 wherein the elongated closed end pipe and distributor trough are positioned at an angle.
15. The method of claim 12, 13 or 14, wherein the waste flammable gas is conducted to two or more elongated closed end pipes having elongated linear openings therein and having elongated flammable gas distributor troughs attached thereto that form elongated discharge slots.
16. The method of any one of claims 12 to 15, wherein the flammable gas distributor trough is attached to the closed end pipe by one or more spring assemblies so that the slots that discharge waste flammable gas increase or decrease in width when the pressure of waste flammable gas increases or decreases.
17. The method of claim 16 wherein the spring assemblies are attached to the bottom of the flammable gas distributor trough and to the closed end pipe.
18. The method of claim 16 wherein the spring assemblies are attached to the inside of the closed end pipe and to the flammable gas distributor trough.
19. The method of claim 16 wherein the spring assemblies are attached to the top of the closed end pipe and to the flammable gas distributor trough.
20. The method of any one of claims 16 to 19, which further comprises additional spring assemblies attached to the closed end pipe that exert pressure on the ends of the elongated flammable gas distributor trough to thereby prevent loss of the pressurized waste flammable gas through the ends of the distributor trough.
21. The method of any one of claims 12 to 20, wherein a small amount of a purge gas is flowed through the flare apparatus when waste flammable gas is not being flared to prevent the entry of air into the flare apparatus.

