



INTERNATIONAL APPLICATION PUBLISHED UNDER THE PATENT COOPERATION TREATY (PCT)

<p>(51) International Patent Classification ⁷ : G02F 1/167, G09F 9/37</p>	<p>A1</p>	<p>(11) International Publication Number: WO 00/03291 (43) International Publication Date: 20 January 2000 (20.01.00)</p>
<p>(21) International Application Number: PCT/US99/15591 (22) International Filing Date: 8 July 1999 (08.07.99) (30) Priority Data: 60/092,050 8 July 1998 (08.07.98) US (71) Applicant: E INK CORPORATION [US/US]; 45 Spinelli Place, Cambridge, MA 02138 (US). (72) Inventors: JACOBSON, Joseph; 223 Grant Avenue, Newton, MA 02159 (US). DRZAIC, Paul; 6234 Lexington Ridge Drive, Lexington, MA 02421 (US). MORRISON, Ian; 18 Prescott Street, Acton, MA 01720 (US). WILCOX, Russell, J.; 17 Winnemay Street, Natick, MA 01760 (US). (74) Agent: LANZA, John, D.; Testa, Hurwitz & Thibault, L.L.P., High Street Tower, 125 High Street, Boston, MA 02110 (US).</p>	<p>(81) Designated States: AE, AL, AM, AT, AU, AZ, BA, BB, BG, BR, BY, CA, CH, CN, CU, CZ, DE, DK, EE, ES, FI, GB, GD, GE, GH, GM, HR, HU, ID, IL, IN, IS, JP, KE, KG, KP, KR, KZ, LC, LK, LR, LS, LT, LU, LV, MD, MG, MK, MN, MW, MX, NO, NZ, PL, PT, RO, RU, SD, SE, SG, SI, SK, SL, TJ, TM, TR, TT, UA, UG, UZ, VN, YU, ZA, ZW, ARIPO patent (GH, GM, KE, LS, MW, SD, SL, SZ, UG, ZW), Eurasian patent (AM, AZ, BY, KG, KZ, MD, RU, TJ, TM), European patent (AT, BE, CH, CY, DE, DK, ES, FI, FR, GB, GR, IE, IT, LU, MC, NL, PT, SE), OAPI patent (BF, BJ, CF, CG, CI, CM, GA, GN, GW, ML, MR, NE, SN, TD, TG).</p> <p>Published <i>With international search report. Before the expiration of the time limit for amending the claims and to be republished in the event of the receipt of amendments.</i></p>	

(54) Title: METHODS FOR ACHIEVING IMPROVED COLOR IN MICROENCAPSULATED ELECTROPHORETIC DEVICES

(57) Abstract

A method for manufacturing a full color, reflective display includes the steps of depositing a first plurality of electrophoretic display elements in substantial registration with a first electrode and a second plurality of electrophoretic display elements in substantial registration with a second electrode. The electrophoretic display elements include a capsule containing a species of particles dispersed in a suspending fluid. The selective deposition of the display elements can be achieved by ink-jet printing methods, screen printing methods or other printing methods. In some embodiments the electrodes are printed onto the substrate before selective deposition of the display elements, while in other embodiments the substrate is provided having the electrodes already disposed on it. In still other embodiments, the sequence of printing of electrodes and electrophoretic display elements can be varied.

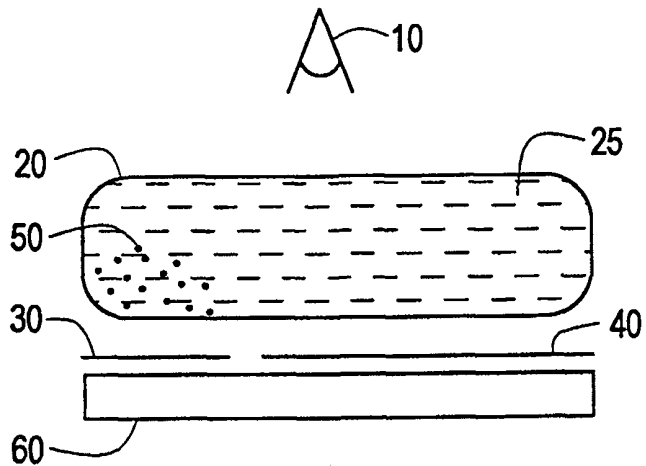

FOR THE PURPOSES OF INFORMATION ONLY

Codes used to identify States party to the PCT on the front pages of pamphlets publishing international applications under the PCT.

AL	Albania	ES	Spain	LS	Lesotho	SI	Slovenia
AM	Armenia	FI	Finland	LT	Lithuania	SK	Slovakia
AT	Austria	FR	France	LU	Luxembourg	SN	Senegal
AU	Australia	GA	Gabon	LV	Latvia	SZ	Swaziland
AZ	Azerbaijan	GB	United Kingdom	MC	Monaco	TD	Chad
BA	Bosnia and Herzegovina	GE	Georgia	MD	Republic of Moldova	TG	Togo
BB	Barbados	GH	Ghana	MG	Madagascar	TJ	Tajikistan
BE	Belgium	GN	Guinea	MK	The former Yugoslav Republic of Macedonia	TM	Turkmenistan
BF	Burkina Faso	GR	Greece			TR	Turkey
BG	Bulgaria	HU	Hungary	ML	Mali	TT	Trinidad and Tobago
BJ	Benin	IE	Ireland	MN	Mongolia	UA	Ukraine
BR	Brazil	IL	Israel	MR	Mauritania	UG	Uganda
BY	Belarus	IS	Iceland	MW	Malawi	US	United States of America
CA	Canada	IT	Italy	MX	Mexico	UZ	Uzbekistan
CF	Central African Republic	JP	Japan	NE	Niger	VN	Viet Nam
CG	Congo	KE	Kenya	NL	Netherlands	YU	Yugoslavia
CH	Switzerland	KG	Kyrgyzstan	NO	Norway	ZW	Zimbabwe
CI	Côte d'Ivoire	KP	Democratic People's Republic of Korea	NZ	New Zealand		
CM	Cameroon			PL	Poland		
CN	China	KR	Republic of Korea	PT	Portugal		
CU	Cuba	KZ	Kazakistan	RO	Romania		
CZ	Czech Republic	LC	Saint Lucia	RU	Russian Federation		
DE	Germany	LI	Liechtenstein	SD	Sudan		
DK	Denmark	LK	Sri Lanka	SE	Sweden		
EE	Estonia	LR	Liberia	SG	Singapore		

METHODS FOR ACHIEVING IMPROVED COLOR IN MICROENCAPSULATED ELECTROPHORETIC DEVICES

Field of the Invention

The present invention relates to electronic displays and, in particular, to full color electrophoretic displays and methods of manufacturing full-color microencapsulated electrophoretic displays.

5 Cross-Reference to Related Applications

This application claims priority to U.S.S.N. 60/092,050 filed July 8, 1998, the contents of which is incorporated herein by reference.

Background of the Invention

10 Electrophoretic display media are generally characterized by the movement of particles through an applied electric field. These displays are highly reflective, can be made bistable, can be scaled to large areas, and consume very little power. These properties allow encapsulated electrophoretic display media to be used in many applications for which traditional electronic displays are not suitable. While bichromatic electrophoretic displays have been demonstrated in a limited range of colors (e.g. black/white or yellow/red), to date there has not been successful
15 commercialization of a full-color electrophoretic display. One reason for this failure of commercialization is the lack of a method of manufacture that is efficient and inexpensive.

One traditional technique for achieving a bright, full-color display which is known in the art of emissive displays is to create display elements that are red, green and blue. In this system, each element has two states: on, or the emission of color; and off. Since light blends from these
20 elements, the overall display can take on a variety of colors and color combinations. In an emissive display, the visual result is the summation of the wavelengths emitted by the display elements at selected intensities, white is seen when red, green and blue are all active in balanced proportion. The brightness of the white image is controlled by the intensities of emission of light by the individual display elements. Black is seen when none are active or, equivalently, when all

- 2 -

are emitting at zero intensity. As an additional example, a red visual display appears when the red display element is active while the green and blue are inactive, and thus only red light is emitted.

This method can be applied to bichromatic reflective displays, typically using the cyan-magenta-yellow subtractive color system. In this system, the reflective display elements absorb characteristic portions of the optical spectrum, rather than generating characteristic portions of the spectrum as do the elements in an emissive display. White reflects everything, or equivalently absorbs nothing. A colored reflective material reflects light corresponding in wavelength to the color seen, and absorbs the remainder of the wavelengths in the visible spectrum. To achieve a black display, all three display elements are turned on, and they absorb complementary portions of the spectrum.

However, such techniques require that the colored display elements be deposited onto a substrate in substantially equal proportions aligned with the proper addressing electrodes. Failure to achieve either substantially equal proportions of colored display elements or failure to achieve registration of the display elements with the addressing electrodes results in a color display that is unsatisfactory.

Summary of the Invention

This invention teaches practical ways to efficiently and cheaply manufacture full-color, encapsulated electrophoretic displays. In one embodiment the display media can be printed and, therefore the display itself can be made inexpensively.

An encapsulated electrophoretic display can be constructed so that the optical state of the display is stable for some length of time. When the display has two states which are stable in this manner, the display is said to be bistable. If more than two states of the display are stable, then the display can be said to be multistable. For the purpose of this invention, the terms bistable and multistable, or generally, stable, will be used to indicate a display in which any optical state remains fixed once the addressing voltage is removed. The definition of a stable state depends on the application for the display. A slowly-decaying optical state can be effectively stable if the optical state is substantially unchanged over the required viewing time. For example, in a display which is updated every few minutes, a display image which is stable for hours or days is effectively bistable or multistable, as the case may be, for that application. In

this invention, the terms bistable and multistable also indicate a display with an optical state sufficiently long-lived as to be effectively stable for the application in mind. Alternatively, it is possible to construct encapsulated electrophoretic displays in which the image decays quickly once the addressing voltage to the display is removed (i.e., the display is not bistable or multistable). As will be described, in some applications it is advantageous to use an
5 encapsulated electrophoretic display which is not bistable or multistable. Whether or not an encapsulated electrophoretic display is stable, and its degree of stability, can be controlled through appropriate chemical modification of the electrophoretic particles, the suspending fluid, the capsule, binder materials, or addressing methods.

10 An encapsulated electrophoretic display may take many forms. The display may comprise capsules dispersed in a binder. The capsules may be of any size or shape. The capsules may, for example, be spherical and may have diameters in the millimeter range or the micron range, but is preferably from ten to a few hundred microns. The capsules may be formed by an encapsulation technique, as described below. Particles may be encapsulated in the
15 capsules. The particles may be two or more different types of particles. The particles may be colored, luminescent, light-absorbing or transparent, for example. The particles may include neat pigments, dyed (laked) pigments or pigment/polymer composites, for example. The display may further comprise a suspending fluid in which the particles are dispersed.

The successful construction of an encapsulated electrophoretic display requires the proper
20 interaction of several different types of materials and processes, such as a polymeric binder and, optionally, a capsule membrane. These materials must be chemically compatible with the electrophoretic particles and fluid, as well as with each other. The capsule materials may engage in useful surface interactions with the electrophoretic particles, or may act as a chemical or physical boundary between the fluid and the binder. Various materials and combinations of
25 materials useful in constructing encapsulated electrophoretic displays are described in co-pending application Serial No. 09/140,861, the contents of which are incorporated by reference herein.

In some cases, the encapsulation step of the process is not necessary, and the electrophoretic fluid may be directly dispersed or emulsified into the binder (or a precursor to the
30 binder materials) and an effective "polymer-dispersed electrophoretic display" constructed. In such displays, voids created in the binder may be referred to as capsules or microcapsules even

though no capsule membrane is present. The binder dispersed electrophoretic display may be of the emulsion or phase separation type.

Throughout the Specification, reference will be made to printing or printed. As used throughout the specification, printing is intended to include all forms of printing and coating, including: premetered coatings such as patch die coating, slot or extrusion coating, slide or cascade coating, and curtain coating; roll coating such as knife over roll coating, forward and reverse roll coating; gravure coating; dip coating; spray coating; meniscus coating; spin coating; brush coating; air knife coating; silk screen printing processes; electrostatic printing processes; thermal printing processes; lithographic printing processes; ink-jet printing processes and other similar techniques. A "printed element" refers to an element formed using any one of the above techniques.

As noted above, electrophoretic display elements can be encapsulated. Throughout the Specification, reference will be made to "capsules," "elements," and "display elements." A capsule or display element may itself comprise one or more capsules or other structures.

In one aspect the present invention relates to a method for manufacturing a color electrophoretic display. A substrate is provided having at least two electrodes. A first plurality of electrophoretic display elements are disposed on the substrate in substantial registration with one of the electrodes. The first plurality of electrophoretic display elements includes capsules containing a first species of particles suspended in a dispersing fluid and having a first optical property. A second plurality of electrophoretic display elements is disposed on the substrate in substantial registration with the other electrode. The second plurality of electrophoretic display elements includes capsules containing a second species of particles suspended in a dispersing fluid and having a second optical property.

In another aspect the present invention relates to a method for manufacturing a color electrophoretic display. A substrate is provided. A first plurality of electrophoretic display elements are disposed on the substrate. The first plurality of electrophoretic display elements includes capsules containing a first species of particles suspended in a dispersing fluid and having a first optical property. At least one electrode is deposited on the first plurality of electrophoretic display elements.

In still another aspect the present invention relates to a method for manufacturing a color electrophoretic display. A substrate is provided and at least two electrodes are deposited on the substrate. A first plurality of electrophoretic display elements are disposed on the substrate in

substantial registration with one of the electrodes. The first plurality of electrophoretic display elements includes capsules containing a first species of particles suspended in a dispersing fluid and having a first optical property. A second plurality of electrophoretic display elements is disposed on the substrate in substantial registration with the other electrode. The second
5 plurality of electrophoretic display elements includes capsules containing a second species of particles suspended in a dispersing fluid and having a second optical property.

In yet another aspect the present invention relates to a method for manufacturing a color electrophoretic display. A substrate is provided and a first plurality of electrophoretic display elements are disposed on the substrate. The first plurality of electrophoretic display elements
10 includes capsules containing a first species of particles suspended in a dispersing fluid and having a first optical property. A second substrate is provided and at least one electrode is deposited on the second substrate. The first and second substrate are disposed adjacent each other so that the display elements are adjacent the electrode.

Brief Description of the Drawings

15 The invention is pointed out with particularity in the appended claims. The advantages of the invention described above, together with further advantages, may be better understood by referring to the following description taken in conjunction with the accompanying drawings. In the drawings, like reference characters generally refer to the same parts throughout the different views. Also, the drawings are not necessarily to scale, emphasis instead generally being placed
20 upon illustrating the principles of the invention.

FIG. 1A is a diagrammatic side view of an embodiment of a rear-addressing electrode structure for a particle-based display in which a smaller electrode has been placed at a voltage relative to the large electrode causing the particles to migrate to the smaller electrode.

25 FIG. 1B is a diagrammatic side view of an embodiment of a rear-addressing electrode structure for a particle-based display in which the larger electrode has been placed at a voltage relative to the smaller electrode causing the particles to migrate to the larger electrode.

FIG. 1C is a diagrammatic top-down view of one embodiment of a rear-addressing electrode structure.

30 FIG. 1D is a diagrammatic side view of one embodiment of a display having three display elements, each display element being produced by a printing process.

FIG. 1E is a diagrammatic plan view of one embodiment of a display having three display elements, each display element being produced by a printing process.

FIG. 2 is a cross-sectional view of a rear electrode addressing structure that is formed by printing.

5 FIG. 3A is a schematic flow diagram of selected steps in a method of manufacturing a display that employs a process in which electrodes are first printed on a substrate, followed by the printing of display elements upon the electrodes.

FIG. 3B is a schematic flow diagram of selected steps in a method of manufacturing a display that employs a process in which display elements are first printed on a substrate,
10 followed by the printing of electrodes upon the display elements.

FIG. 3C is a schematic flow diagram of selected steps in a method of manufacturing a display that employs a process in which electrodes are printed on a first substrate, display elements are printed on a second substrate, and the two structures are combined to form a display.

15 FIG. 3D is a diagrammatic side view of an embodiment of an addressing structure having transparent electrodes, in which an alternating-current electric field has been applied to the capsule causing the particles to disperse into the capsule.

FIG. 3E is a diagrammatic side view of an embodiment of an addressing structure for a display element having three sub-pixels.

20 FIG. 3F is a diagrammatic side view of an embodiment of a dual particle curtain mode addressing structure addressing a display element to appear white.

FIG. 3G is a diagrammatic side view of an embodiment of a dual particle curtain mode addressing structure addressing a display element to appear red.

25 FIG. 3H is a diagrammatic side view of an embodiment of a dual particle curtain mode addressing structure addressing a display element to absorb red light.

FIG. 3I is a diagrammatic side view of an embodiment of a dual particle curtain mode addressing structure for a display element having three sub-pixels, in which the display is addressed to appear red.

30 FIG. 3J is a diagrammatic side view of another embodiment of a dual particle curtain mode addressing structure for a display element.

FIG. 3K is a diagrammatic plan view of an embodiment of an interdigitated electrode structure.

FIG. 3L is a diagrammatic side view of another embodiment of a dual particle curtain mode display structure having a dyed fluid and two species of particles, addressed to absorb red.

FIG. 3M is a diagrammatic side view of another embodiment of a dual particle curtain mode display structure having clear fluid and three species of particles, addressed to absorb red.

5 FIG. 4A depicts an embodiment of a manufacturing process that employs a drum for printing electrodes or display elements.

FIG. 4B depicts an embodiment of a manufacturing process that employs an inkjet for printing electrodes or display elements.

10 FIG. 4C depicts an embodiment of a manufacturing process that employs a flat platen for printing electrodes or display elements.

FIG. 5 is a flowchart showing the steps to be taken to fabricate a display using a method of the present invention.

Detailed Description of the Invention

15 Electronic ink is an optoelectronically active material that comprises at least two phases: an electrophoretic contrast media phase and a coating/binding phase. The electrophoretic phase comprises, in some embodiments, a single species of electrophoretic particles dispersed in a clear or dyed medium, or more than one species of electrophoretic particles having distinct physical and electrical characteristics dispersed in a clear or dyed medium. In some embodiments the
20 electrophoretic phase is encapsulated, that is, there is a capsule wall phase between the two phases. The coating/binding phase includes, in one embodiment, a polymer matrix that surrounds the electrophoretic phase. In this embodiment, the polymer in the polymeric binder is capable of being dried, crosslinked, or otherwise cured as in traditional inks, and therefore a printing process can be used to deposit the electronic ink onto a substrate.

25 In one embodiment, the ink may comprise display elements capable of displaying different colors. In one particular embodiment, some display elements contain red particles, some display elements contain green particles, and some display elements contain blue particles, respectively. In another particular embodiment, some display elements contain cyan particles, some display elements contain magenta particles, and some display elements contain yellow
30 particles, respectively. By addressing each display element to display some fraction of its colored particles, a display can be caused to give an appearance corresponding to a selected color at a selected brightness level.

Electronic ink is capable of being printed by several different processes, depending on the mechanical properties of the specific ink employed. For example, the fragility or viscosity of a particular ink may result in a different process selection. A very viscous ink would not be well-suited to deposition by an inkjet printing process, while a fragile ink might not be used in a knife
5 over roll coating process.

The optical quality of an electronic ink is quite distinct from other electronic display materials. The most notable difference is that the electronic ink provides a high degree of both reflectance and contrast because it is pigment based (as are ordinary printing inks). The light scattered from the electronic ink comes from a very thin layer of pigment close to the viewing
10 surface. In this respect it resembles an ordinary, printed image. Also, electronic ink is easily viewed from a wide range of viewing angles in the same manner as a printed page, and such ink approximates a Lambertian contrast curve more closely than any other electronic display material. Since electronic ink can be printed, it can be included on the same surface with any other printed material, including traditional inks. Electronic ink can be made optically stable in
15 all display configurations, that is, the ink can be set to a persistent optical state. Fabrication of a display by printing an electronic ink is particularly useful in low power applications because of this stability.

Electronic ink displays are novel in that they can be addressed by DC voltages and draw very little current. Therefore, elements forming electronic inks may be made of non-traditional
20 materials and electronic inks may be manufactured by and used in non-traditional methods. As such, the conductive leads and electrodes used to deliver the voltage to electronic ink displays can be of relatively high resistivity. The ability to use resistive conductors substantially widens the number and type of materials that can be used as conductors in electronic ink displays. In particular, the use of costly vacuum-sputtered indium tin oxide (ITO) conductors, a standard
25 material in liquid crystal devices, is not required. Aside from cost savings, the replacement of ITO with other materials can provide benefits in appearance, processing capabilities (printed conductors), flexibility, and durability. Additionally, the printed electrodes are in contact only with a solid binder, not with a fluid layer (like liquid crystals). This means that some conductive materials, which would otherwise dissolve or be degraded by contact with liquid crystals, can be
30 used in an electronic ink application. These include opaque metallic inks for the rear electrode (e.g., silver and graphite inks), as well as conductive transparent inks for either substrate. These conductive coatings include semiconducting colloids, examples of which are indium tin oxide

and antimony-doped tin oxide. Organic conductors (polymeric conductors and molecular organic conductors) also may be used. Polymers include, but are not limited to, polyaniline and derivatives, polythiophene and derivatives, poly3,4-ethylenedioxythiophene (PEDOT) and derivatives, polypyrrole and derivatives, and polyphenylenevinylene (PPV) and derivatives.

5 Organic molecular conductors include, but are not limited to, derivatives of naphthalene, phthalocyanine, and pentacene. Polymer layers can be made thinner and more transparent than with traditional displays because conductivity requirements are not as stringent.

As an example, there is a class of materials called electroconductive powders which are also useful as coatable transparent conductors in electronic ink displays. One example is Zelec
10 ECP electroconductive powders from DuPont Chemical Co. of Wilmington, Delaware.

It is possible to produce a wide gamut of colors from the superposition of suitable proportions of three properly chosen colors. In one embodiment, the colors red, green, and blue can be combined in various proportions to produce an image that is perceived as a selected color. Emissive or transmissive displays operate according to additive rules, where the perceived color
15 is created by summing the emission wavelengths of a plurality of emitting or transmitting objects. For an emissive or transmissive display that includes three display elements, one of which can produce red light, one green light, and one blue light, respectively, one can generate a wide gamut of colors, as well as white and black. At one extreme, the combination of all three at full intensity is perceived as white, and at the other, the combination of all three at zero intensity
20 is perceived as black. Specific combinations of controlled proportions of these three colors can be used to represent other colors.

In a reflective display, the light that a viewer perceives is the portion of the spectrum that is not absorbed when the light to be reflected falls on the reflector surface. One may thus consider a reflecting system as a subtractive system, that is, that each reflective surface
25 "subtracts" from the light that portion which the reflector absorbs. The color of a reflector represents the wavelengths of light the reflector absorbs. A yellow reflector absorbs substantially blue light. A magenta reflector absorbs substantially green light. A cyan reflector absorbs substantially red light. Thus, in an alternative embodiment employing reflectors, nearly the same results as an emissive system can be obtained by use of the three colors cyan, yellow, and
30 magenta as the primary colors, from which all other colors, including black but not white, can be derived. To obtain white from such a display, one must further introduce a third state per display element, namely white.

While the methods described discuss particles, any combination of dyes, liquids droplets and transparent regions that respond to electrophoretic effects could also be used. Particles of various optical effects may be combined in any suitable proportion. For example, certain colors may be over- or under-populated in the electrophoretic display, for example, by printing more display elements of one color than of another color, to account for the sensitivities of the human eye and to thereby achieve a more pleasing or uniform effect. Similarly, the sizes of the display elements may also be disproportionate to achieve various optical effects.

Although these examples describe microencapsulated electrophoretic displays, the invention can be utilized across other reflective displays including liquid crystal, polymer-dispersed liquid crystal, rotating ball, suspended particle and any other reflective display capable of being printed. In short, many schemes are possible by which display elements in a direct color reflective display can be printed. Such printing schemes will vary by the nature of the display and any suitable means may be used.

Referring now to FIGs. 1A and 1B, an addressing scheme for controlling particle-based displays is shown in which electrodes are disposed on only one side of a display, allowing the display to be rear-addressed. Utilizing only one side of the display for electrodes simplifies fabrication of displays. For example, if the electrodes are disposed on only the rear side of a display, both of the electrodes can be fabricated using opaque materials, which may be colored, because the electrodes do not need to be transparent.

FIG. 1A depicts a single capsule 20 of an encapsulated display media. In brief overview, the embodiment depicted in FIG. 1A includes a capsule 20 containing at least one particle 50 dispersed in a suspending fluid 25. The capsule 20 is addressed by a first electrode 30 and a second electrode 40. The first electrode 30 is smaller than the second electrode 40. The first electrode 30 and the second electrode 40 may be set to voltage potentials which affect the position of the particles 50 in the capsule 20.

The particles 50 represent 0.1% to 20% of the volume enclosed by the capsule 20. In some embodiments the particles 50 represent 2.5% to 17.5% of the volume enclosed by capsule 20. In preferred embodiments, the particles 50 represent 5% to 15% of the volume enclosed by the capsule 20. In more preferred embodiments the particles 50 represent 9% to 11% of the volume defined by the capsule 20. In general, the volume percentage of the capsule 20 that the particles 50 represent should be selected so that the particles 50 expose most of the second, larger electrode 40 when positioned over the first, smaller electrode 30. As described in detail below,

the particles 50 may be colored any one of a number of colors. The particles 50 may be either positively charged or negatively charged.

The particles 50 are dispersed in a dispersing fluid 25. The dispersing fluid 25 should have a low dielectric constant. The fluid 25 may be clear, or substantially clear, so that the fluid 25 does not inhibit viewing the particles 50 and the electrodes 30, 40 from position 10. In other embodiments, the fluid 25 is dyed. In some embodiments the dispersing fluid 25 has a specific gravity substantially matched to the density of the particles 50. These embodiments can provide a bistable display media, because the particles 50 do not tend to move absent an electric field applied via the electrodes 30, 40.

The electrodes 30, 40 should be sized and positioned appropriately so that together they address the entire capsule 20. There may be exactly one pair of electrodes 30, 40 per capsule 20, multiple pairs of electrodes 30, 40 per capsule 20, or a single pair of electrodes 30, 40 may span multiple capsules 20. In the embodiment shown in FIGs. 1A and 1B, the capsule 20 has a flattened, rectangular shape. In these embodiments, the electrodes 30, 40 should address most, or all, of the flattened surface area adjacent the electrodes 30, 40. The smaller electrode 30 is at most one-half the size of the larger electrode 40. In preferred embodiments the smaller electrode is one-quarter the size of the larger electrode 40; in more preferred embodiments the smaller electrode 30 is one-eighth the size of the larger electrode 40. In even more preferred embodiments, the smaller electrode 30 is one-sixteenth the size of the larger electrode 40. It should be noted that reference to "smaller" in connection with the electrode 30 means that the electrode 30 addresses a smaller amount of the surface area of the capsule 20, not necessarily that the electrode 30 is physically smaller than the larger electrode 40. For example, multiple capsules 20 may be positioned such that less of each capsule 20 is addressed by the "smaller" electrode 30, even though both electrodes 30, 40 are equal in size. It should also be noted that, as shown in FIG. 1C, electrode 30 may address only a small corner of a rectangular capsule 20 (shown in phantom view in FIG. 1C), requiring the larger electrode 40 to surround the smaller electrode 30 on two sides in order to properly address the capsule 20. Further, electrodes may be of any shape, such as concentric rings or rectangles. Selection of the percentage volume of the particles 50 and the electrodes 30, 40 in this manner allow the encapsulated display media to be addressed as described below.

Electrodes generally may be fabricated from any material capable of conducting electricity so that electrode 30, 40 may apply an electric field to the capsule 20. In the

embodiments to be discussed here, conductive material may be printed by using conductive ink. Conductive inks are well known and may be prepared by including in the ink fluid a conductive material such as powdered metal or powdered graphite. As noted above, the rear-addressed embodiments depicted in FIGs. 1A and 1B allow the electrodes 30, 40 to be fabricated from
5 opaque materials such as solder paste, copper, copper-clad polyimide, graphite inks, silver inks and other metal-containing conductive inks. Alternatively, electrodes may be fabricated using transparent materials such as indium tin oxide and conductive polymers such as polyaniline or polythiopenes. Electrodes 30, 40 may be provided with contrasting optical properties. In some
10 embodiments, one of the electrodes has an optical property complementary to optical properties of the particles 50. Alternatively, since the electrodes need not be transparent, an electrode can be constructed so as to display a selected color. Since electric current is not always required to be conducted from an electrode to a display element, but is only required to flow within the electrode to set up an electric field, one is in general able to overcoat the electrode with a colored
15 ink so as to impart a desired color to an electrode, without detrimental effect on the operation of an electrode.

The operation of the electrophoretic display element will be presented with regard to an embodiment that displays two states, for example, black and white. In this embodiment, the capsule 20 contains positively charged black particles 50, and a substantially clear suspending fluid 25. The first, smaller electrode 30 is colored black, and is smaller than the second electrode
20 40, which is colored white or is highly reflective. When the smaller, black electrode 30 is placed at a negative voltage potential relative to larger, white electrode 40, the positively-charged particles 50 migrate to the smaller, black electrode 30. The effect to a viewer of the capsule 20 located at position 10 is a mixture of the larger, white electrode 40 and the smaller, black
25 electrode 30, creating an effect which is largely white. Referring to FIG. 1B, when the smaller, black electrode 30 is placed at a positive voltage potential relative to the larger, white electrode 40, particles 50 migrate to the larger, white electrode 40 and the viewer is presented a mixture of the black particles 50 covering the larger, white electrode 40 and the smaller, black electrode 30, creating an effect which is largely black. In this manner the capsule 20 may be addressed to display either a white visual state or a black visual state.

30 Other two-color schemes are easily provided by varying the color of the smaller electrode 30 and the particles 50 or by varying the color of the larger electrode 40. For example, varying the color of the larger electrode 40 allows fabrication of a rear-addressed, two-color display

- 13 -

having black as one of the colors. Alternatively, varying the color of the smaller electrode 30 and the particles 50 allow a rear-addressed two-color system to be fabricated using white as one of the colors. Further, it is contemplated that the particles 50 and the smaller electrode 30 can be different colors. In these embodiments, a two-color display may be fabricated having a second
5 color that is different from the color of the smaller electrode 30 and the particles 50. For example, a rear-addressed, orange-white display may be fabricated by providing blue particles 50, a red, smaller electrode 30, and a white (or highly reflective) larger electrode 40. In general, the optical properties of the electrodes 30, 40 and the particles 50 can be independently selected to provide desired display characteristics. In some embodiments the optical properties of the
10 dispersing fluid 25 may also be varied, e.g. the fluid 25 may be dyed.

In another embodiment, this technique may be used to provide a full color display. Referring now to FIGs. 1D and 1E, an embodiment is depicted that comprises three display elements. It should be understood that although FIGs. 1D and 1E depict rectangular elements having equally-sized display elements, an element may have any shape and a display may be
15 comprised of display elements that are unequal in size or shape, or alternatively the display may be comprised of display elements that are unequal in number by color or optical property. The display elements may each be formed as a single large capsule, or each may be distributed across any number of small capsules or cells. For the purposes of illustration, the simpler case of a single large capsule for each display element is shown. In both cases we refer to the regions 20,
20 20', 20'', as capsules. Thus, a first capsule 20 contains positively charged black particles 50 and a substantially clear suspending fluid 25. A first, smaller electrode 30 is colored black, and is smaller than the second electrode 40, which is colored red. When the smaller, black electrode 30 is placed at a negative voltage potential relative to larger, red electrode 40, the positively-charged particles 50 migrate to the smaller, black electrode 30. The effect to a viewer of the capsule 20
25 located at position 10 is a mixture of the larger, red electrode 40 and the smaller, black electrode 30, creating an effect which is largely red. When the smaller, black electrode 30 is placed at a positive voltage potential relative to the larger, red electrode 40, particles 50 migrate to the larger, red electrode 40 and the viewer is presented a mixture of the black particles 50 covering the larger, red electrode 40 and the smaller, black electrode 30, creating an effect which is largely
30 black. In this manner the first capsule 20 may be addressed to display either a red visual state or a black visual state. One can equally have a second capsule 20' wherein the larger electrode 40' is green, and a third capsule 20'' wherein the larger electrode 40'' is blue. A second capsule 20'

- 14 -

contains positively charged black particles 50' and a substantially clear suspending fluid 25'. A first, smaller electrode 30' is colored black, and is smaller than the second electrode 40', which is colored green. When the smaller, black electrode 30' is placed at a negative voltage potential relative to larger, green electrode 40', the positively-charged particles 50' migrate to the smaller, black electrode 30'. The effect to a viewer of the capsule 20' located at position 10' is a mixture of the larger, green electrode 40' and the smaller, black electrode 30', creating an effect which is largely green. When the smaller, black electrode 30' is placed at a positive voltage potential relative to the larger, green electrode 40', particles 50' migrate to the larger, green electrode 40' and the viewer is presented a mixture of the black particles 50' covering the larger, green electrode 40' and the smaller, black electrode 30', creating an effect which is largely black. Similarly, a third capsule 20'' contains positively charged black particles 50'' and a substantially clear suspending fluid 25''. A first, smaller electrode 30'' is colored black, and is smaller than the second electrode 40'', which is colored blue. When the smaller, black electrode 30'' is placed at a negative voltage potential relative to larger, blue electrode 40'', the positively-charged particles 50'' migrate to the smaller, black electrode 30''. The effect to a viewer of the capsule 20'' located at position 10'' is a mixture of the larger, blue electrode 40'' and the smaller, black electrode 30'', creating an effect which is largely blue. When the smaller, black electrode 30'' is placed at a positive voltage potential relative to the larger, blue electrode 40'', particles 50'' migrate to the larger, blue electrode 40'' and the viewer is presented a mixture of the black particles 50'' covering the larger, blue electrode 40'' and the smaller, black electrode 30'', creating an effect which is largely black. Further, the relative intensities of these colors can be controlled by the actual voltage potentials applied to the electrodes. By choosing appropriate combinations of the three colors, one may create a visual display which appears as the effective combination of the selected colors as an additive process. As an alternative embodiment, the first, second and third capsules can have larger electrodes 40, 40', 40'' which are respectively colored cyan, yellow, and magenta. Operation of the alternative cyan, yellow, and magenta embodiment is analogous to that of the red, green, and blue embodiment, with the feature that the color to be displayed is selected by a subtractive process.

In other embodiments the larger electrode 40 may be transparent or reflective instead of white. In these embodiments, when the particles 50 are moved to the smaller electrode 30, light reflects off the reflective surface of the larger electrode 40 and the capsule 20 appears light in color, e.g. white. When the particles 50 are moved to the larger electrode 40, the reflecting

surface is obscured and the capsule 20 appears dark because light is absorbed by the particles 50 before reaching the reflecting surface. In other embodiments, proper switching of the particles may be accomplished with a combination of alternating-current (AC) and direct-current (DC) electric fields.

5 In still other embodiments, the rear-addressed display previously discussed can be configured to transition between largely transmissive and largely opaque modes of operation (referred to hereafter as "shutter mode"). Referring back to FIGs. 1A and 1B, in these embodiments the capsule 20 contains at least one positively-charged particle 50 dispersed in a substantially clear dispersing fluid 25. The larger electrode 40 is transparent and the smaller
10 electrode 30 is opaque. When the smaller, opaque electrode 30 is placed at a negative voltage potential relative to the larger, transmissive electrode 40, the particles 50 migrate to the smaller, opaque electrode 30. The effect to a viewer of the capsule 20 located at position 10 is a mixture of the larger, transparent electrode 40 and the smaller, opaque electrode 30, creating an effect which is largely transparent. Referring to FIG. 1B, when the smaller, opaque electrode 30 is
15 placed at a positive voltage potential relative to the larger, transparent electrode 40, particles 50 migrate to the second electrode 40 and the viewer is presented a mixture of the opaque particles 50 covering the larger, transparent electrode 40 and the smaller, opaque electrode 30, creating an effect which is largely opaque. In this manner, a display formed using the capsules depicted in FIGs. 1A and 1B may be switched between transmissive and opaque modes. In some
20 embodiments the electrodes may be disposed on the viewing side of the capsule 20. Such a display can be used to construct a window that can be rendered opaque or a wide range of colors by using a tinted electrode. Although FIGs. 1A-1D depict a pair of electrodes associated with each capsule 20, it should be understood that each pair of electrodes may be associated with more than one capsule 20.

25 A similar technique may be used in connection with the embodiment of FIGs. 3A, 3B, 3C, and 3D. Referring to FIG. 3A, a capsule 20 contains at least one dark or black particle 50 dispersed in a substantially clear dispersing fluid 25. A smaller, opaque electrode 30 and a larger, transparent electrode 40 apply both direct-current (DC) electric fields and alternating-current (AC) fields to the capsule 20. A DC field can be applied to the capsule 20 to cause the
30 particles 50 to migrate towards the smaller electrode 30. For example, if the particles 50 are positively charged, the smaller electrode is placed a voltage that is more negative than the larger

electrode 40. Although FIGs. 3A-3D depict only one capsule per electrode pair, multiple capsules may be addressed using the same electrode pair.

The smaller electrode 30 is at most one-half the size of the larger electrode 40. In preferred embodiments the smaller electrode is one-quarter the size of the larger electrode 40; in more preferred embodiments the smaller electrode 30 is one-eighth the size of the larger electrode 40. In even more preferred embodiments, the smaller electrode 30 is one-sixteenth the size of the larger electrode 40.

Causing the particles 50 to migrate to the smaller electrode 30, as depicted in FIG. 3A, allows incident light to pass through the larger, transparent electrode 40 and be reflected by a reflecting surface 60. In shutter mode, the reflecting surface 60 is replaced by a translucent layer, a transparent layer, or a layer is not provided at all, and incident light is allowed to pass through the capsule 20, i.e. the capsule 20 is transmissive. If the translucent layer or the transparent layer comprises a color, such as a color filter, the light that is transmitted will be those wavelengths that the filter passes, and the reflected light will consist of those wavelengths that the filter reflects, while the wavelengths that the filter absorbs will be lost. The visual appearance of a shutter mode display may thus depend on whether the display is in a transmissive or reflective condition, on the characteristics of the filter, and on the position of the viewer.

Referring now to FIG. 3B, the particles 50 are dispersed throughout the capsule 20 by applying an AC field to the capsule 20 via the electrodes 30, 40. The particles 50, dispersed into the capsule 20 by the AC field, block incident light from passing through the capsule 20, causing it to appear dark at the viewpoint 10. The embodiment depicted in FIGs. 3A-3B may be used in shutter mode by not providing the reflecting surface 60 and instead providing a translucent layer, a transparent layer, a color filter layer, or no layer at all. In shutter mode, application of an AC electric field causes the capsule 20 to appear opaque. The transparency of a shutter mode display formed by the apparatus depicted in FIGs. 3A-3D may be controlled by the number of capsules addressed using DC fields and AC fields. For example, a display in which every other capsule 20 is addressed using an AC field would appear about half as transmissive as when the particles are all addressed by the AC field.

FIGs. 3C and 3D depict an embodiment of the electrode structure described above in which electrodes 30, 40 are on "top" of the capsule 20, that is, the electrodes 30, 40 are between the viewpoint 10 and the capsule 20. In these embodiments, both electrodes 30, 40 should be transparent. Transparent conducting layers can be fabricated using conductive polymers, such as

polyaniline, polythiophenes, indium tin oxide, or polymers containing conducting particles less than 100 nanometers in diameter such as copper iodide, ionic polymers, or sputtered polymers. These materials may be made soluble so that electrodes can be fabricated using coating techniques such as spin coating, spray coating, meniscus coating, printing techniques, forward and reverse roll coating and the like. In these embodiments, light passes through the electrodes 30, 40 and is either absorbed by the particles 50, reflected by reflecting layer 60 (when provided), transmitted throughout the capsule 20 (when reflecting layer 60 is not provided), or partially transmitted and/or reflected if a color filter is present in place of retroreflecting layer 60.

Referring to FIG. 3E, three display element capsules 22, 22' and 22'' each contain at least one white particle 50 dispersed in a substantially clear dispersing fluid 25. In one embodiment, each display element capsule 22, 22' and 22'' has a transparent electrode 42, 42', and 42'' disposed above it and a colored filter 60, 60' and 60'' disposed below it. A common reflective surface 70 may be shared behind the color filter layer. In an alternative embodiment, the display includes an emissive light source 70

Smaller, opaque electrodes 30, 30' and 30'' and larger, transparent electrodes 40, 40' and 40'' may apply direct-current (DC) electric fields and alternating-current (AC) fields to the capsules 20, 20' and 20''. A DC field can be applied to the capsules 20, 20' and 20'' to cause the particles 50, 50' and 50'' to migrate towards the smaller electrodes 30, 30' and 30''. For example, if the particles 50, 50' and 50'' are positively charged, the smaller electrodes 30, 30' and 30'' are placed a voltage that is more negative than the larger electrodes 40, 40' and 40''.

The smaller electrode 30 is at most one-half the size of the larger electrode 40. In preferred embodiments the smaller electrode 30 is one-quarter the size of the larger electrode 40; in more preferred embodiments the smaller electrode 30 is one-eighth the size of the larger electrode 40. In even more preferred embodiments, the smaller electrode 30 is one-sixteenth the size of the larger electrode 40.

Causing the particles 50 to migrate to the smaller electrode 30, as depicted in the first two capsules of FIG. 3E, allows incident light to pass through the larger, transparent electrode 40, through filter 60, reflect off substrate 70 and pass back through the device. If the first, second and third filters 60, 60' and 60'' are colored cyan, magenta, and yellow respectively, and the particles 50 are white, this system can display full color in a standard two-color fashion.

The filter layer 60 may be a translucent layer, a transparent layer, a color filter layer, or a layer is not provided at all, and further substrate 70 may be reflective, emissive, translucent or

- 18 -

not provided at all. If the layer 60 comprises a color, such as a color filter, the light which is transmitted will be those wavelengths that the filter passes, and the reflected light will consist of those wavelengths that the filter reflects, while the wavelengths that the filter absorbs will be lost. The visual appearance of a the display element in 3E may thus depend on whether the display is in a transmissive or reflective condition, on the characteristics of the filter, and on the position of the viewer. In an alternative embodiment layer 60 may be provided on top of the capsule adjacent to electrode 42.

Referring now to FIGS. 3F-3K, one embodiment of a tri-color element is described.

Clear electrode 42 allows light to pass into capsule 22 and to strike either white particles W, red particles R, or a colored substrate 60. The substrate 60 can be a combination of color filter and non-colored substrate or it can be provided as a unitary colored substrate. Capsule 22 also includes a suspending fluid that can be dye-colored (possibly eliminating the need for a separate color filter 60) or substantially clear. Electrodes 45 and 35 are transparent and may be equally sized or sized in any suitable manner taking into account the relative particles sizes and

mobilities of particles W and R. A gap exists between 45 and 35. Assume that particles W are negatively charged and particles R are positively charged. In FIG. 3F, top electrode 42 is set at a positive voltage potential relative to bottom electrodes 35 and 45, moving particles W to the top and particles R to the bottom and thus white is displayed. In FIG. 3G by reversing the polarity of the electrodes, red is displayed. In both FIGS. 3F and 3G the particles obscure substrate 60. In

FIG. 3H electrode 45 is at a negative voltage potential relative to electrode 35, while electrode 42 is at a voltage potential between the potentials of 45 and 35, such as zero. Alternatively,

electrode 42 switches between the potentials of 45 and 35 so that over time the effective voltage of 42 is again between the potentials of 45 and 35. In this state, the particles R move toward electrode 45 and the particles W move toward electrode 35 and both particles R and W move away from the gap in the center of the capsule 22. This reveals substrate 60, permitting a third color such as cyan to be imaged. In alternate embodiments the color combinations can differ.

The specific colors of the filters and particles need not differ. This system, called "dual particle curtain mode," can image three arbitrary colors. In a preferred embodiment the colors are as described wherein one color is white and the other two colors are complements. In this manner,

referring again to FIG. 3H, if a small portion of red is visible it absorbs part of the light reflected from the cyan substrate and the net result is black, which may be offset by a small portion of visible white. Thus, the element in FIG. 3H may appear to be cyan even if some red and white is

visible. As mentioned above, the edges of the element may be masked to hide particles R and W when in the mode shown in FIG. 3H.

Referring now to FIG. 3I, a full-color element is shown comprising three display elements, each operating in the manner taught by FIGS. 3F-3H wherein the colored particles are positively charged, and the white particles are negatively charged. The system may still function with top electrode 42 extended as a common top electrode as shown in FIG. 3I. For example, to achieve the state shown, electrodes 42, 45, 35, 45', 35', 45'', 35'' may be set to voltage potentials - 30V, 60V, 60V, -60V, +60V, -60V, +60V respectively.

Referring now to FIGS. 3J-3K, an electrode scheme is shown whereby a cluster of microcapsules may be addressed for an entire display element in a manner similar to those described above. Clear electrode 42 allows light to pass into microcapsules 27 and to strike either white particles W, red particles R, or colored substrate 60. As above, colored substrate 60 may be a combination of color filter and non-colored substrate 60 or colored substrate 60 may be provided as a unitary colored substrate. Capsules 27 include a suspending fluid that may be dyed-colored (possibly eliminating the need for a separate color filter 60) or substantially clear. Electrodes 45 and 35 are transparent and may be equally sized or sized in any suitable manner taking into account the relative particle sizes and mobilities of particles W and R. A gap exists between 45 and 35. Assume that particles W are negatively charged and particles R are positively charged. The system operates in the manner described in FIGS. 3F-3K, although for any given microcapsule 27 there may be multiple gaps. FIG. 3K illustrates an embodiment of a suitable electrode pattern in which 45 and 35 are interdigitated.

Referring now to 3L-3M, an alternate embodiment is shown. Again clear electrode 42 allows light to pass into capsule 22 and to strike white particles W or red particles R. In the embodiment shown in FIG. 3L, capsule 22 includes a suspending fluid 62 that is dyed cyan. When electrodes 45 and 35 are set at appropriate voltages particles, R and W move down to electrodes 45 and 35 respectively, where they are obscured by light-absorbing suspending fluid 62. Alternatively, as shown in FIG. 3M, suspending fluid 62 is substantially clear and a third species of cyan particles C is included in capsules 22. The cyan particles have a relatively neutral charge. When electrodes 45 and 35 are set at appropriate voltages particles R and W move down to electrodes 45 and 35 respectively, revealing the cyan particles.

The addressing structure depicted in FIGS. 3A-3M may be used with electrophoretic display media and encapsulated electrophoretic display media. FIGS. 3A-3M depict

embodiments in which electrode 30, 40 are statically attached to the display media. In certain embodiments, the particles 50 exhibit bistability, that is, they are substantially motionless in the absence of a electric field.

While various of the substrates described above are reflective, an analogous technique
5 may be employed wherein the substrates emit light, with the particles again acting in a “shutter mode” to reveal or obscure light. A preferred substrate for this use is an electroluminiscent (EL) backlight. Such a backlight can be reflective when inactive, often with a whitish-green color, yet emit lights in various wavelengths when active. By using whitish EL substrates in place of static white reflective substrates, it is possible to construct a full-color reflective display that can also
10 switch its mode of operation to display a range of colors in an emissive state, permitting operation in low ambient light conditions.

FIGs. 4A and 4B depict an embodiment of a rear-addressing electrode structure that creates a reflective color display in a manner similar to halftoning or pointillism. The capsule 20 contains white particles 55 dispersed in a clear suspending fluid 25. Electrodes 42, 44, 46, 48 are
15 colored cyan, magenta, yellow, and white respectively. Referring to FIG 4A, when the colored electrodes 42, 44, 46 are placed at a positive potential relative to the white electrode 48, negatively-charged particles 55 migrate to these three electrodes, causing the capsule 20 to present to the viewpoint 10 a mix of the white particles 55 and the white electrode 48, creating an effect which is largely white. Referring to FIG. 4B, when electrodes 42, 44, 46 are placed at a
20 negative potential relative to electrode 48, particles 55 migrate to the white electrode 48, and the eye 10 sees a mix of the white particles 55, the cyan electrode 42, the magenta electrode 44, and the yellow electrode 46, creating an effect which is largely black or gray. By addressing the electrodes, any color can be produced that is possible with a subtractive color process. For example, to cause the capsule 20 to display a red color to the viewpoint 10, the yellow electrode
25 46 and the magenta electrode 42 are set to a voltage potential that is more positive than the voltage potential applied by the cyan electrode 42 and the white electrode 48. Further, the relative intensities of these colors can be controlled by the actual voltage potentials applied to the electrodes. Again, AC current may be used appropriately to randomize the position of the particles as a step in this process.

30 The technique used in FIGs. 4A and 4B could be used in a similar manner with fewer electrodes and controlling fewer colors. For example, if electrode 42 were not present, the element could still display three colors. If electrodes 44 and 46 were colored red and cyan

respectively, the capsule could display red, cyan and white. This construction could be used then employed as a display element, to be matched with similar display elements displaying other trios of colors thus achieving a full-color display as described above.

The addressing structures described in FIGS. 1-4B typically comprise a top electrode
5 controlled by display driver circuitry. It may be seen that if the top electrode is absent, the display may be imaged by an externally applied voltage source, such as a passing stylus or electrostatic print head. The means that techniques applied above to generate a full-color electrophoretic display could also be applied for a full-color electrophoretic media.

As will be evident from the above discussion, color electrophoretic displays require
10 careful registration of display elements to the electrodes used to address those display elements. Referring now to FIG. 5, steps that may be taken to efficiently and cheaply manufacture a display while avoiding the registration problems of prior art display are shown.

A substrate is provided that has at least two electrodes (step 502). The number of
electrodes provided will vary depending on the number of regions to be individually addressed.
15 For example, in a traditional RGB display, three electrodes or sets of electrodes may be provided in order to address red capsules, green capsules, and blue capsules. The electrodes may have a predetermined pattern of interest. For example, a display may include both electronic ink and traditional, printed inks. In such a display, the electrodes may be patterned to address only those portions of the display meant to bear electronic ink.

20 In some embodiments, the substrate is provided and the electrodes are printed on the substrate using any one of a number of printing techniques. Referring now to FIG. 6, the structure of a printed electrode is shown. A conductive material 162 can be printed onto an insulative substrate 160. In some embodiments, such as the one shown in FIG. 6, the substrate 160 defines one or more vias 164 that allow the printed conductive material 162 to be driven by
25 addressing logic 166. The addressing logic 166 may also be printed.

Referring back to FIG. 5, a first plurality of electrophoretic display elements is selectively
printed on the substrate in substantial registration with at least one of the electrodes disposed on
the substrate (step 504). The electrophoretic display elements generally are capsules containing
one or more species of particles in a dispersing fluid as described above in connection with FIGS.
30 1-4B. The display elements, which may form the contrast phase of an electronic ink, may be printed onto the substrate using any of the printing techniques described above. In certain embodiments, the printing technique itself provides the accuracy necessary to register the display

elements to the appropriate electrode. For example, an ink-jet printing process could be used to print red capsules in substantial registration with a "red" electrode, green capsules in substantial registration with a "green" electrode, and blue capsules in substantial registration with a "blue" electrode. The capsules can be printed sequentially or an ink-jet head may be used that allows
5 red, green, and blue capsules to be simultaneously printed in a selective fashion.

In some embodiments, the display elements may be coated onto the substrate using an intermediate having a substantially cylindrical surface or a substantially flat surface, such as a lithographic belt. In specific embodiments, the intermediate is a roller, belt, blotter, brush, or sponge. The display elements may be held to the intermediate by electrostatic forces, surface
10 tension, chemical bonding forces, or an applied electric field.

The properties of the binder phase can be adjusted to match the desired printing process. For example, an ink to be used in inkjet printing may be adjusted to have a low viscosity. An ink suitable for lithographic printing may be adjusted to have a suitable contact angle. The display elements can be dispersed in a suitable carrier fluid such as water or an organic solvent that is
15 dried after coating. The carrier fluid can also contain agents to modify surface tension, contact angle, viscosity, or electrical conductivity. The binder phase may contain monomers, oligomers, polymers, or polymerization inhibitors. These components can be used to form physically robust display element layers.

In one embodiment the display elements could be dispersed in a low viscosity
20 water solution containing a polymer. This solution could be inkjet printed in registration with the appropriate electrode pattern. In another embodiment the display element can be dispersed in an ultraviolet-curable resin used in lithographic printing processes, deposited on the appropriate electrodes by a lithographic process, and cured to form the display element layer. In all cases, the display elements are printed in substantial registration with the appropriate electrodes.

25 In other embodiments, the electronic ink is coated onto the substrate using an appropriate coating method such as knife-over-roll coating, silk-screen printing processes, brushing or other non-patterned coating techniques. In these embodiments, an electric signal is applied to the electrode to which the display elements should be registered. Application of an electric signal attracts the display elements proximate the electrode. For certain embodiments employing a
30 carrier, the applied signal overcomes the forces holding the display elements to the carrier and transfers the elements to the substrate adjacent the electrode. The display elements can be dispersed in a low viscosity liquid, such as low molecular weight hydrocarbons like

methylethylketone or cyclohexane, or alcohols such as ethanol or propanol. The display elements are then treated to produce a controlled surface charge by, for example, adjusting the pH of the dispersing liquid or adding surface active agents such as soaps, detergents, or other dispersants. Because the charge of the display elements is controlled, an electric charge can be
5 use to transfer the display elements to the appropriate electrode.

Other display elements may then be removed from the substrate, e.g. by washing the substrate, to leave only the display elements that are proximate to the electrode. A second plurality of electrophoretic display elements are selectively deposited on the substrate in substantial registration with another electrode (step 506) using techniques similar to those just
10 described. The technique used to selectively deposit the first plurality of display elements need not be the same technique as that used to selectively deposit the second plurality of display elements.

This technique for printing displays can be used to build the rear electrode structure on a display or to construct two separate layers that are laminated together to form the display. For
15 example an electronically active ink may be printed on an indium tin oxide electrode. Separately, a rear electrode structure as described above can be printed on a suitable substrate, such as plastic, polymer films, or glass. The electrode structure and the display element can be laminated to form a display.

While the examples described here are listed using encapsulated electrophoretic displays,
20 there are other particle-based display media which should also work as well, including encapsulated suspended particles and rotating ball displays.

While the invention has been particularly shown and described with reference to specific preferred embodiments, it should be understood by those skilled in the art that various changes in form and detail may be made therein without departing from the spirit and scope of the invention
25 as defined by the appended claims.

CLAIMS

What is claimed is:

- 1 1. A method of manufacturing a color electrophoretic display comprising the steps of:
 - 2 (a) providing a substrate having at least two electrodes disposed thereon;
 - 3 (b) selectively depositing a first plurality of electrophoretic display elements in substantial
4 registration with a first electrode, each of said first plurality of display elements comprising a
5 capsule containing a plurality of a first species of particles, said first species of particles
6 responsive to a first applied electric field and having a first optical property; and
 - 7 (c) selectively depositing a second plurality of electrophoretic display elements in substantial
8 registration with a second electrode, each of said second plurality of display elements comprising
9 a capsule containing a plurality of a second species of particles, said second species of particles
10 responsive to a second applied electric field and having a second optical property.
- 1 2. The method of claim 1, wherein step (a) comprises the step of: providing a substrate
2 having at least two electrodes disposed thereon, at least one of said at least two electrodes having
3 a pre-determined pattern.
- 1 3. The method of claim 1, wherein step (a) comprises the steps of:
 - 2 (a-a) providing a substrate; and
 - 3 (a-b) depositing at least two electrodes on said substrate.
- 1 4. The method of claim 3, wherein step (a-b) comprises depositing at least two electrodes on
2 said substrate, at least one of said at least two electrodes having a pre-determined pattern.
- 1 5. The method of claim 1, wherein step (b) comprises selectively depositing by ink-jet
2 printing a first plurality of electrophoretic display elements in substantial registration with the at
3 least one electrode, each of said first plurality of display elements comprising a capsule
4 containing a plurality of a first species of particles, said first species of particles responsive to a
5 first applied electric field and having a first optical property.
- 1 6. The method of claim 1, wherein step (b) comprises selectively depositing by screen
2 printing a first plurality of electrophoretic display elements in substantial registration with the at
3 least one electrode, each of said first plurality of display elements comprising a capsule
4 containing a plurality of a first species of particles, said first species of particles responsive to a
5 first applied electric field and having a first optical property.

1 7. The method of claim 1, wherein step (b) comprises selectively depositing by gravure
2 printing a first plurality of electrophoretic display elements in substantial registration with the at
3 least one electrode, each of said first plurality of display elements comprising a capsule
4 containing a plurality of a first species of particles, said first species of particles responsive to a
5 first applied electric field and having a first optical property.

1 8. The method of claim 1, wherein step (b) comprises:

2 (b-a) providing a carrier bearing a first plurality of electrophoretic display elements, each of
3 said first plurality of display elements comprising a capsule containing a plurality of a first
4 species of particles, said first species of particles responsive to a first applied electric field and
5 having a first optical property;

6 (b-b) disposing said carrier adjacent said substrate; and

7 (b-c) applying an electrical signal to said at least one electrode to transfer at least some of said
8 first plurality of electrophoretic display elements from said carrier to said substrate in substantial
9 registration with said at least one electrode.

1 9. The method of claim 8, wherein step (b-a) comprises providing a carrier bearing a first
2 plurality of electrophoretic display elements, each of said first plurality of display elements
3 comprising a capsule containing a plurality of a first species of particles and a dyed fluid, said
4 first species of particles responsive to a first applied electric field and having a first optical
5 property.

1 10. The method of claim 8, wherein said first plurality of electrophoretic display elements is
2 held upon said carrier by an applied electric field.

1 11. The method of claim 8, wherein said first plurality of electrophoretic display elements is
2 held upon said carrier by electrostatic forces.

1 12. The method of claim 8, wherein said first plurality of electrophoretic display elements is
2 held upon said carrier by chemical bonding forces.

1 13. The method of claim 8, wherein said first plurality of electrophoretic display elements is
2 held upon said carrier by surface tension.

1 14. The method of claim 8, wherein step (b-a) comprises providing a carrier having a
2 substantially flat surface, and bearing a first plurality of electrophoretic display elements, each of
3 said first plurality of display elements comprising a capsule containing a plurality of a first

4 species of particles, said first species of particles responsive to a first applied electric field and
5 having a first optical property.

1 15. The method of claim 8, wherein step (b-a) comprises providing a carrier having a
2 substantially cylindrical surface, and bearing a first plurality of display electrophoretic elements,
3 each of said first plurality of display elements comprising a capsule containing a plurality of a
4 first species of particles, said first species of particles responsive to a first applied electric field
5 and having a first optical property.

1 16. The method of claim 4, wherein step (b-a) comprises providing a carrier that is a fluid,
2 bearing a first plurality of electrophoretic display elements, each of said first plurality of display
3 elements comprising a capsule containing a plurality of a first species of particles, said first
4 species of particles responsive to a first applied electric field and having a first optical property.

1 17. An electrophoretic display manufactured according to the process of claim 1.

1 18. A method of manufacturing an electrophoretic display comprising the steps of:

2 (a) providing a substrate;

3 (b) selectively depositing in a pre-determined pattern upon said substrate a first plurality of
4 electrophoretic display elements, each of said first plurality of display elements comprising a
5 capsule containing a plurality of a first species of particles, said first species of particles
6 responsive to a first applied electric field and having a first optical property;

7 (c) selectively depositing at least one electrode upon said first plurality of electrophoretic
8 display elements;

9 (d) selectively depositing in a pre-determined pattern upon said substrate a second plurality
10 of electrophoretic display elements, each of said second plurality of display elements comprising
11 a capsule containing a plurality of a second species of particles, said second species of particles
12 responsive to a second applied electric field and having a second optical property; and

13 (e) selectively depositing at least one electrode upon said second plurality of electrophoretic
14 display elements.

1 19. The method of claim 18, wherein step (b) comprises selectively depositing in a pre-
2 determined pattern upon said substrate a first plurality of electrophoretic display elements, each
3 of said first plurality of display elements comprising a capsule containing a plurality of a first
4 species of particles and a dyed fluid, said first species of particles responsive to a first applied
5 electric field and having a first optical property.

- 1 20. The method of claim 18, wherein step (c) comprises selectively depositing at least one
2 electrode upon, and in substantial registration with, said first plurality of electrophoretic display
3 elements.
- 1 21. A method of manufacturing an electrophoretic display comprising the steps of:
2 (a) providing a substrate;
3 (b) selectively depositing upon said substrate at least two electrodes;
4 (c) selectively depositing a first plurality of electrophoretic display elements in substantial
5 registration with a first electrode, each of said first plurality of display elements comprising a
6 capsule containing a plurality of a first species of particles, said first species of particles
7 responsive to a first applied electric field and having a first optical property; and
8 (d) selectively depositing a second plurality of electrophoretic display elements in substantial
9 registration with a second electrode, each of said second plurality of display elements comprising
10 a capsule containing a plurality of a second species of particles, said second species of particles
11 responsive to a second applied electric field and having a second optical property.
- 1 22. The method of claim 21, wherein step (b) comprises selectively depositing in a pre-
2 determined pattern upon said substrate at least two electrodes.
- 1 23. The method of claim 22, wherein step (c) comprises selectively depositing upon, and in
2 substantial registration with, a first electrode a first plurality of electrophoretic display elements,
3 each of said first plurality of display elements comprising a capsule containing a plurality of a
4 first species of particles, said first species of particles responsive to a first applied electric field
5 and having a first optical property.
- 1 24. A method of manufacturing an electrophoretic display comprising the steps of:
2 (a) providing a first substrate;
3 (b) selectively depositing in a pre-determined pattern upon said first substrate a first plurality
4 of electrophoretic display elements, each of said first plurality of display elements comprising a
5 capsule containing a plurality of a first species of particles, said first species of particles
6 responsive to a first applied electric field and having a first optical property;
7 (c) providing a second substrate;
8 (d) depositing at least one electrode upon said second substrate; and
9 (e) disposing said first substrate adjacent said second substrate with said first plurality of
10 electrophoretic display elements adjacent said at least one electrode.

- 1 25. The method of claim 24, wherein step (d) comprises depositing at least one electrode
- 2 upon said second substrate in a pattern substantially calculated to match said pre-determined
- 3 pattern.

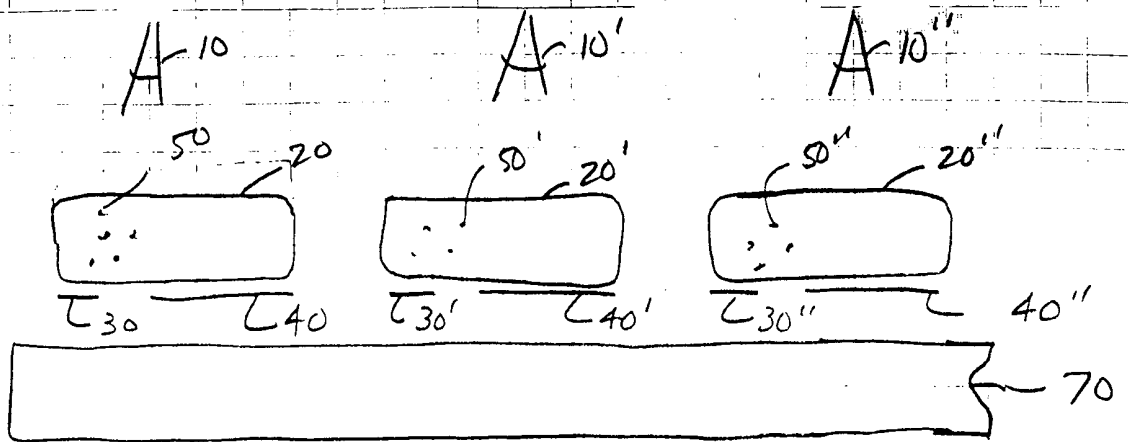

FIG. 1D

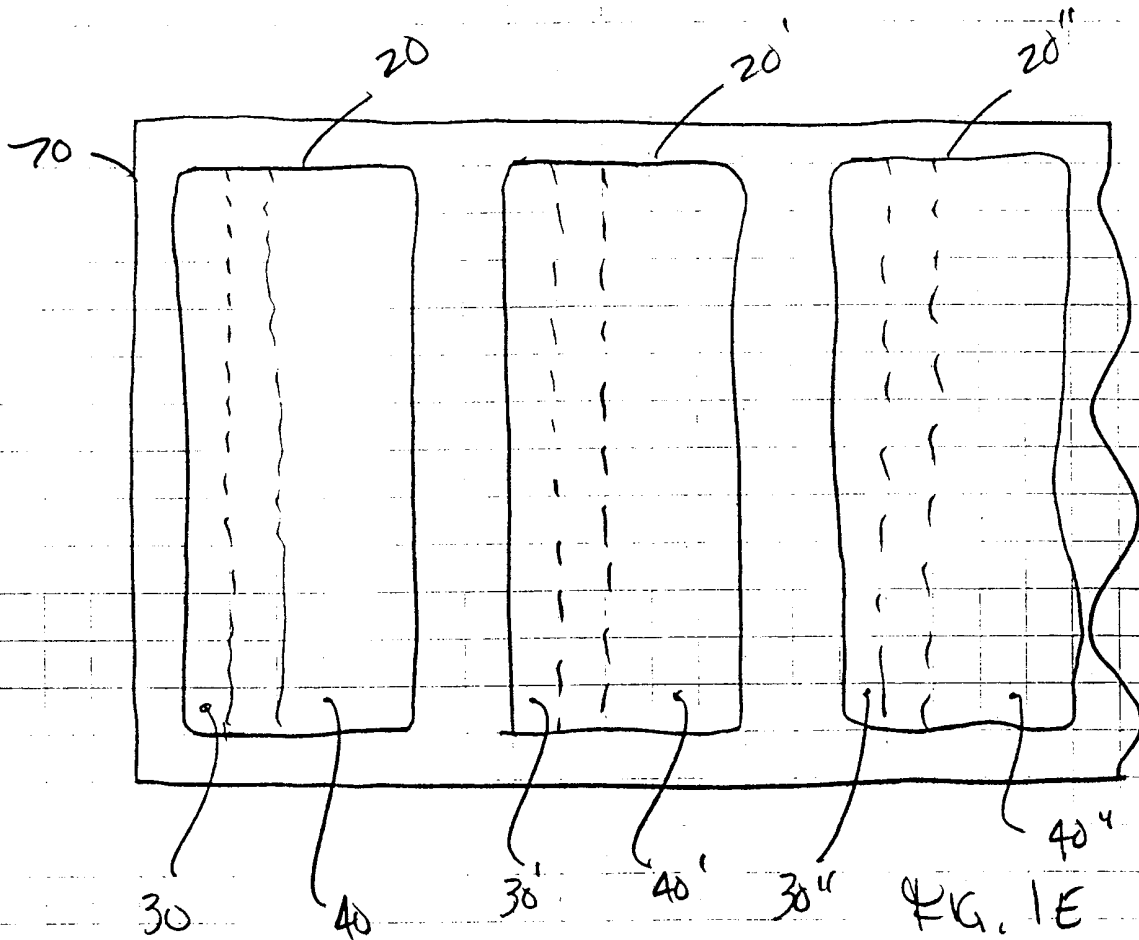

FIG. 1E

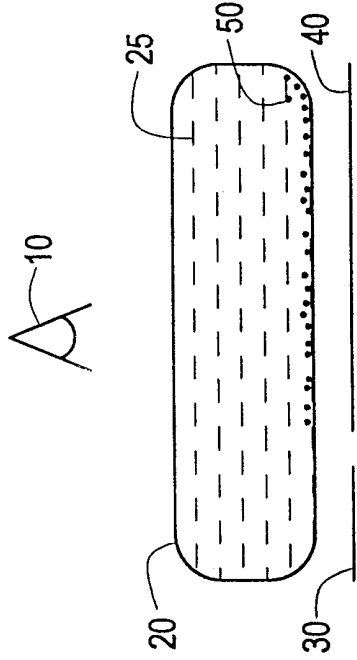

FIG. 1A

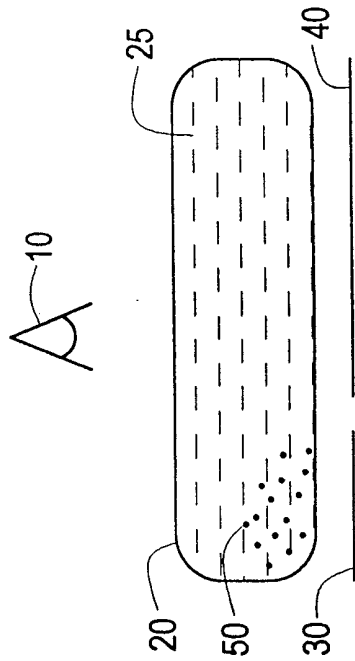

FIG. 1B

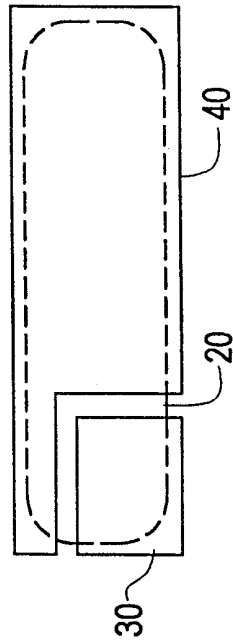

FIG. 1C

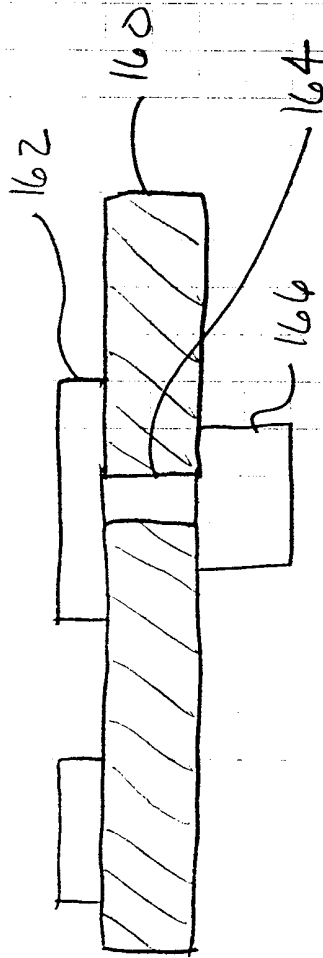

FIG. 2

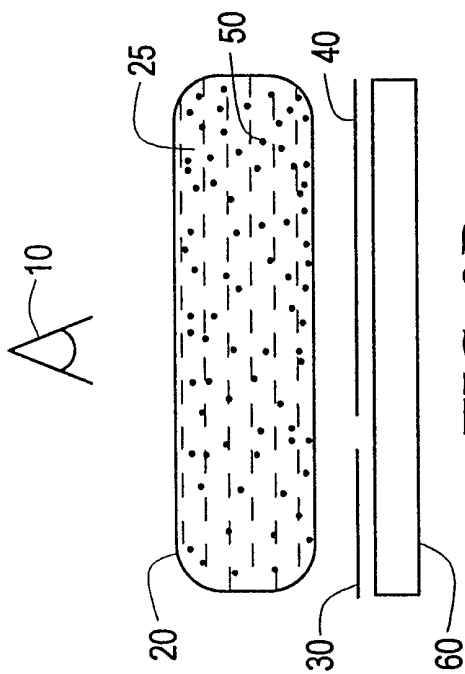

FIG. 3B

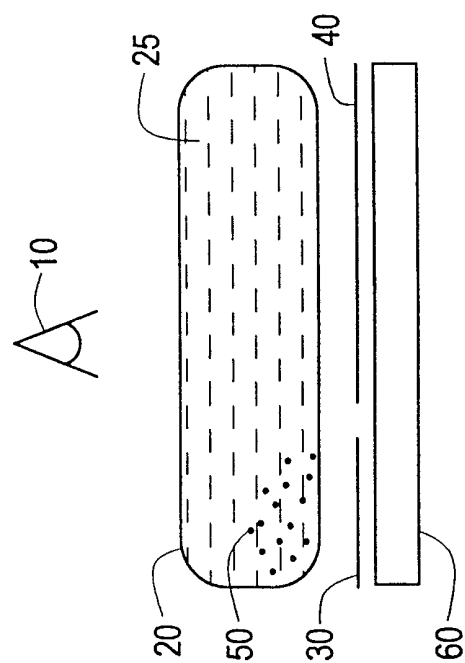

FIG. 3A

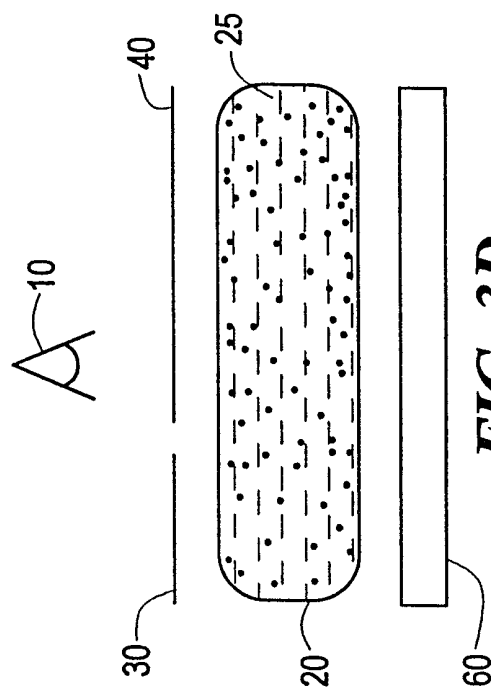

FIG. 3D

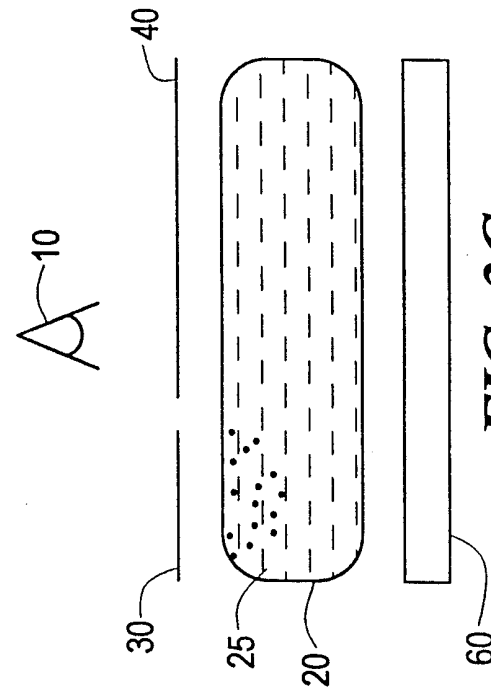

FIG. 3C

Figure 3E

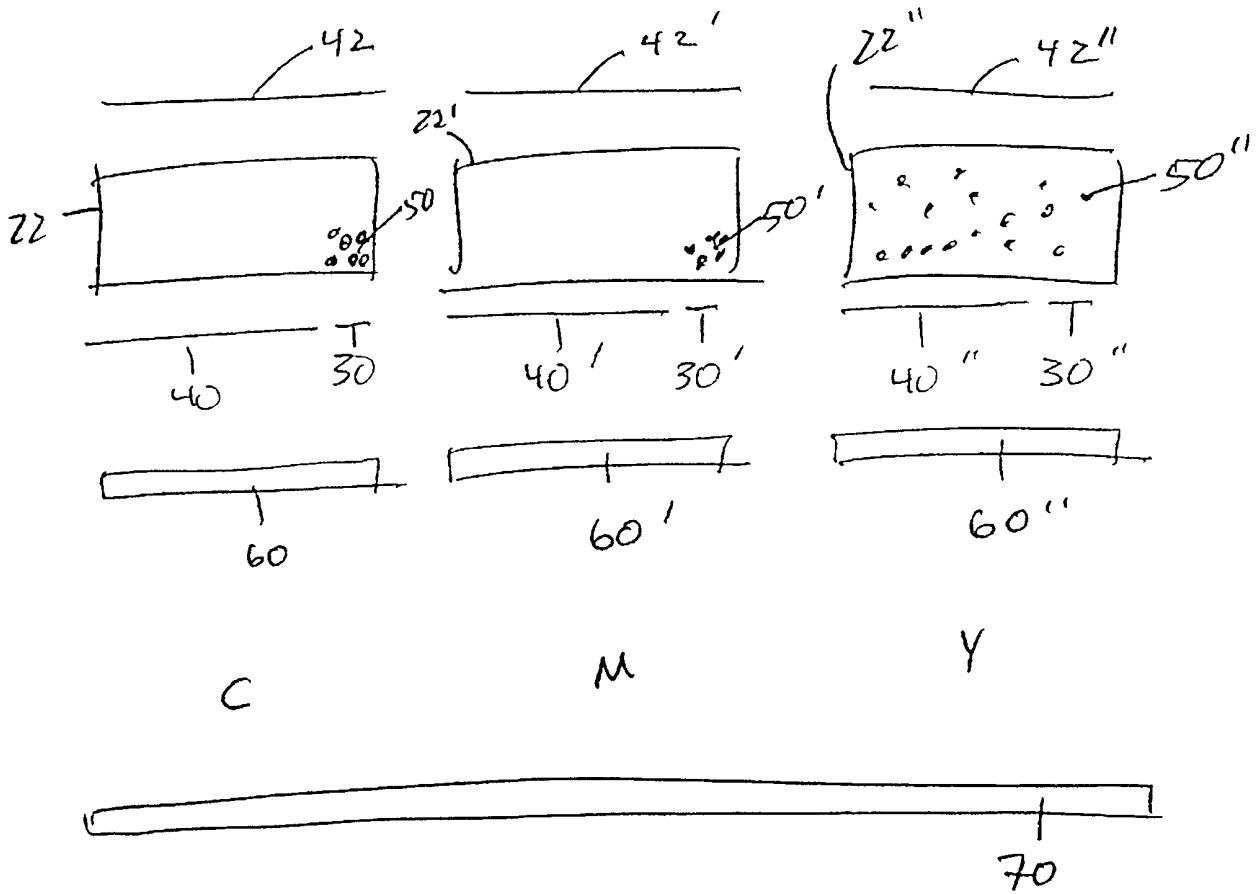

Figure 3F

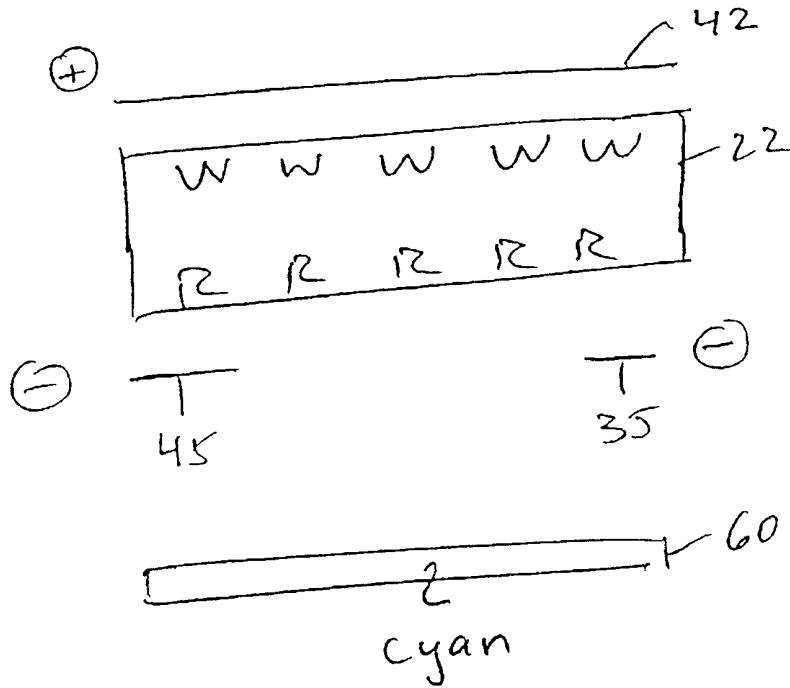
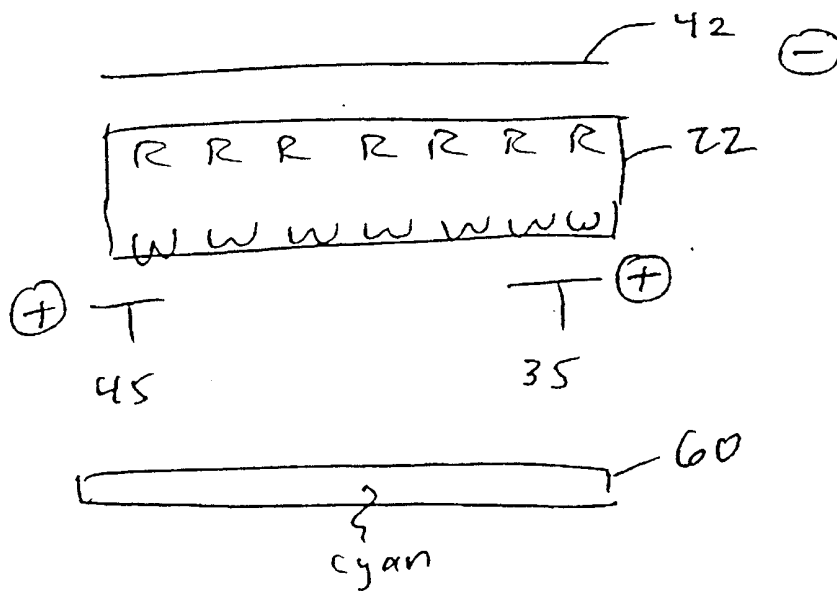

Figure 3G



7/12

Figure 3H

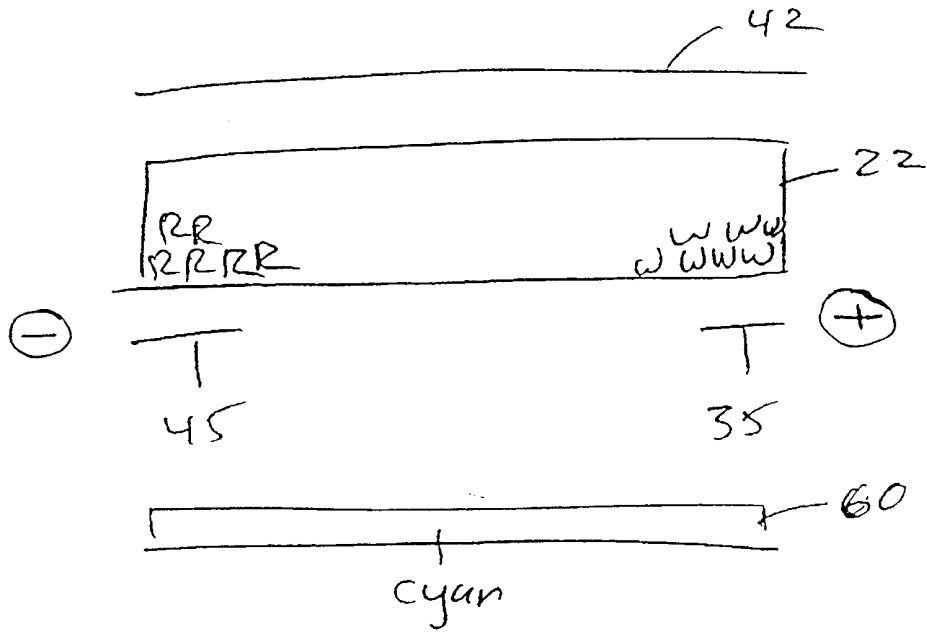
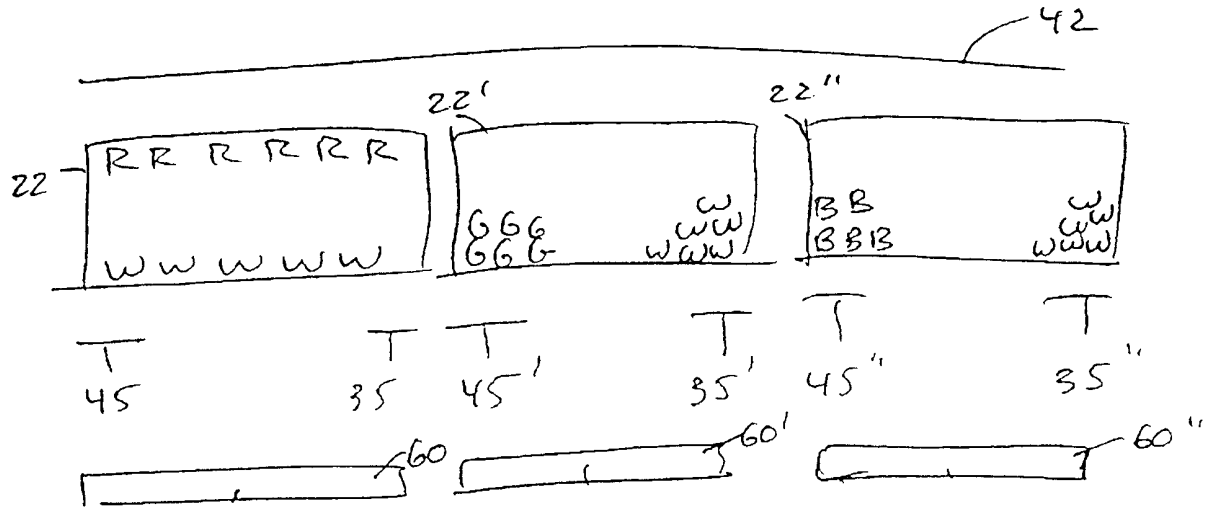

Figure 3I



9/12

Figure 3J

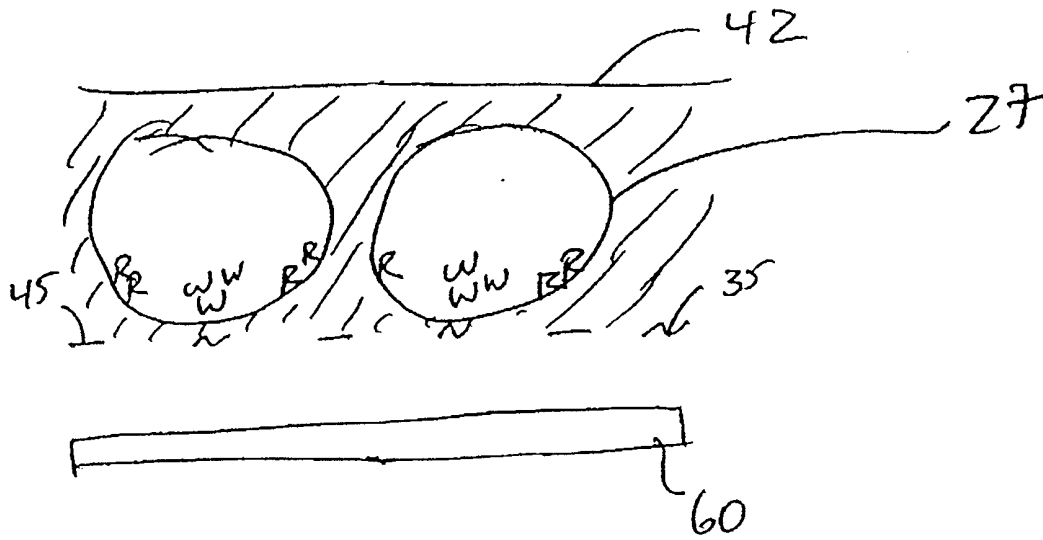

Figure 3K

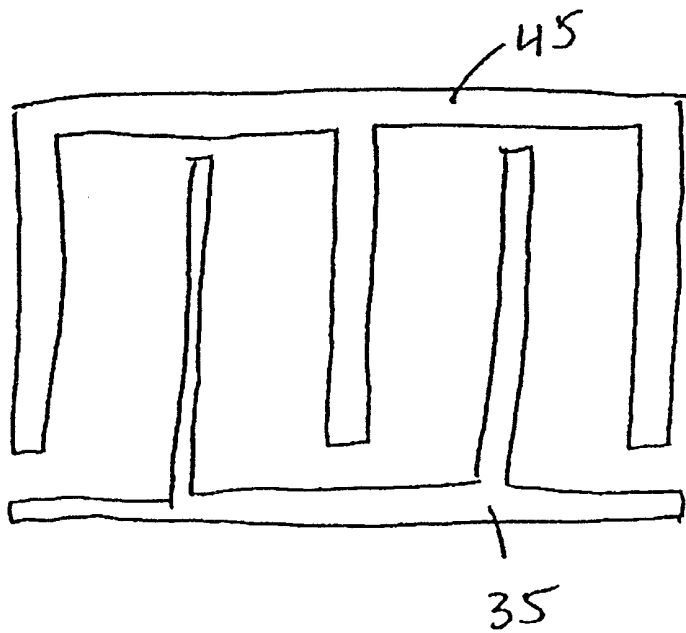

Figure 3L

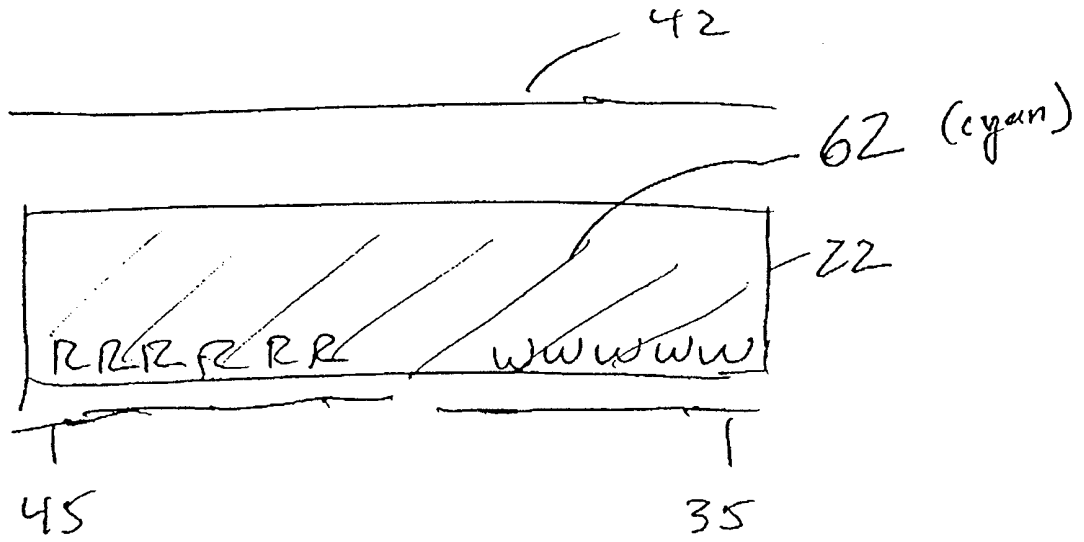
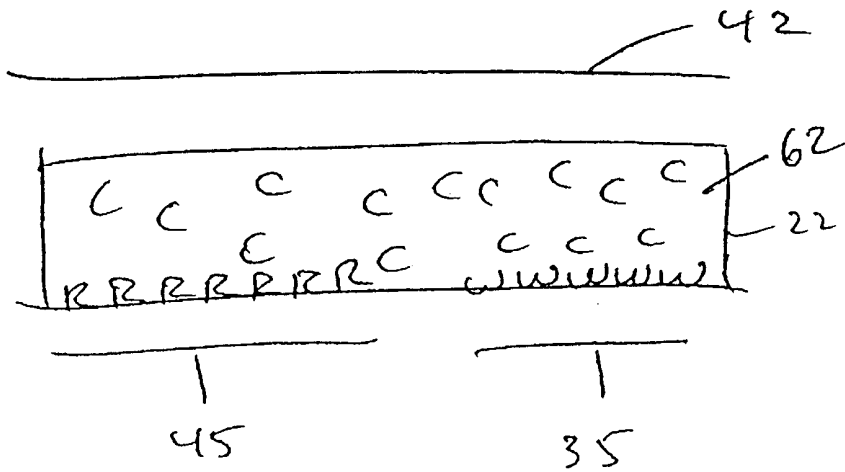

Figure 3M



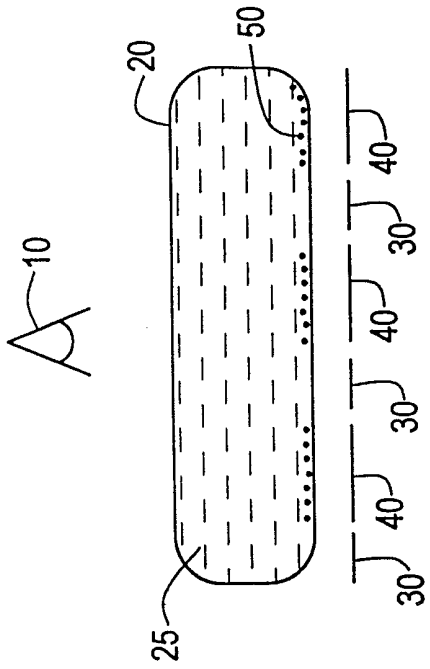

FIG. 4A

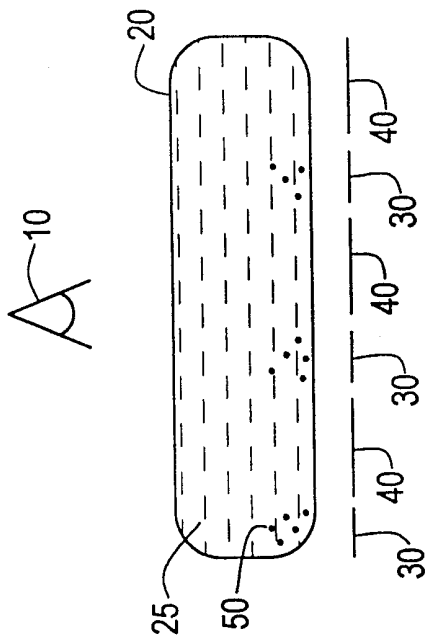

FIG. 4B

12/12

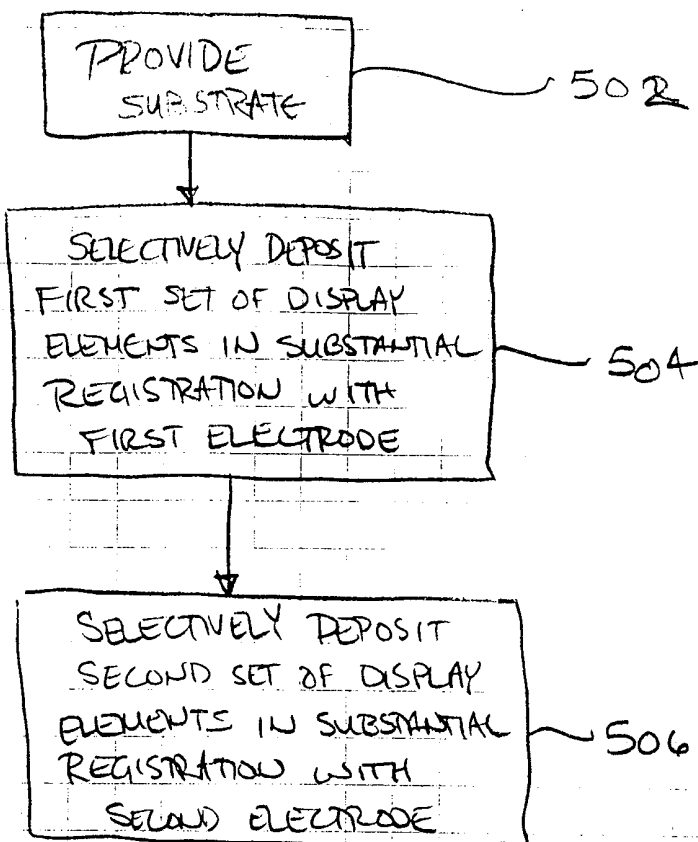

FIG. 5

INTERNATIONAL SEARCH REPORT

International Application No

PCT/US 99/15591

A. CLASSIFICATION OF SUBJECT MATTER
 IPC 7 G02F1/167 G09F9/37

According to International Patent Classification (IPC) or to both national classification and IPC

B. FIELDS SEARCHED

Minimum documentation searched (classification system followed by classification symbols)
 IPC 7 G02F G09F G03G

Documentation searched other than minimum documentation to the extent that such documents are included in the fields searched

Electronic data base consulted during the international search (name of data base and, where practical, search terms used)

C. DOCUMENTS CONSIDERED TO BE RELEVANT

Category °	Citation of document, with indication, where appropriate, of the relevant passages	Relevant to claim No.
Y	PATENT ABSTRACTS OF JAPAN vol. 014, no. 027 (P-992), 19 January 1990 (1990-01-19) & JP 01 267525 A (TOYOTA MOTOR CORP), 25 October 1989 (1989-10-25) abstract & DATABASE WPI Section Ch, Week 198949 Derwent Publications Ltd., London, GB; Class A85, AN 1989-359204 & JP 01 267525 A (TOYOTA JIDOSHA KK), 25 October 1989 (1989-10-25) abstract <div style="text-align: center; margin-top: 10px;"> --- -/-- </div>	1, 3, 8, 17-25

Further documents are listed in the continuation of box C.

Patent family members are listed in annex.

° Special categories of cited documents :

- "A" document defining the general state of the art which is not considered to be of particular relevance
- "E" earlier document but published on or after the international filing date
- "L" document which may throw doubts on priority claim(s) or which is cited to establish the publication date of another citation or other special reason (as specified)
- "O" document referring to an oral disclosure, use, exhibition or other means
- "P" document published prior to the international filing date but later than the priority date claimed

- "T" later document published after the international filing date or priority date and not in conflict with the application but cited to understand the principle or theory underlying the invention
- "X" document of particular relevance; the claimed invention cannot be considered novel or cannot be considered to involve an inventive step when the document is taken alone
- "Y" document of particular relevance; the claimed invention cannot be considered to involve an inventive step when the document is combined with one or more other such documents, such combination being obvious to a person skilled in the art.
- "&" document member of the same patent family

Date of the actual completion of the international search

11 November 1999

Date of mailing of the international search report

19/11/1999

Name and mailing address of the ISA

European Patent Office, P.B. 5818 Patentlaan 2
 NL - 2280 HV Rijswijk
 Tel. (+31-70) 340-2040, Tx. 31 651 epo nl,
 Fax: (+31-70) 340-3016

Authorized officer

Manntz, W

INTERNATIONAL SEARCH REPORT

International Application No

PCT/US 99/15591

C.(Continuation) DOCUMENTS CONSIDERED TO BE RELEVANT		
Category	Citation of document, with indication, where appropriate, of the relevant passages	Relevant to claim No.
Y	PATENT ABSTRACTS OF JAPAN vol. 013, no. 316 (P-900), 18 July 1989 (1989-07-18) & JP 01 086116 A (NIPPON MEKTRON LTD), 30 March 1989 (1989-03-30) abstract ---	1,3,8, 17-25
A	PATENT ABSTRACTS OF JAPAN vol. 017, no. 204 (P-1524), 21 April 1993 (1993-04-21) & JP 04 345133 A (TOYOTA MOTOR CORP), 1 December 1992 (1992-12-01) abstract -& JP 04 345133 A figures 1-4 ---	1-25
P,X	WO 99 10767 A (E INK CORP) 4 March 1999 (1999-03-04) page 8, line 5 -page 11, line 15 page 13, line 16 -page 14, line 18; figures 1-5,9,10 ---	1,3,8, 17-25
A	EP 0 709 713 A (FUJIKURA LTD ;FUJIKURA KASEI KK (JP)) 1 May 1996 (1996-05-01) page 2, line 55 -page 3, line 59 page 6, line 5 -page 7, line 7; figures 1-3 ---	1,18,21, 24
P,A	US 5 894 367 A (SHERIDON NICHOLAS K) 13 April 1999 (1999-04-13) abstract; figure 10C -----	1,18,21, 24

INTERNATIONAL SEARCH REPORT

information on patent family members

International Application No

PCT/US 99/15591

Patent document cited in search report	Publication date	Patent family member(s)	Publication date
JP 01267525 A	25-10-1989	NONE	
JP 01086116 A	30-03-1989	JP 2551783 B	06-11-1996
JP 04345133 A	01-12-1992	JP 2768043 B	25-06-1998
WO 9910767 A	04-03-1999	AU 9122598 A	16-03-1999
		AU 9206398 A	16-03-1999
		AU 9207898 A	16-03-1999
		WO 9910768 A	04-03-1999
		WO 9910769 A	04-03-1999
		AU 9206198 A	16-03-1999
EP 0709713 A	01-05-1996	JP 8129194 A	21-05-1996
		JP 8137416 A	31-05-1996
		JP 8190353 A	23-07-1996
		JP 8179704 A	12-07-1996
		JP 8190351 A	23-07-1996
		JP 8190352 A	23-07-1996
US 5894367 A	13-04-1999	EP 0913804 A	06-05-1999
		JP 11212500 A	06-08-1999