

(19) World Intellectual Property
Organization
International Bureau



(43) International Publication Date
21 October 2004 (21.10.2004)

PCT

(10) International Publication Number
WO 2004/089249 A1

- (51) International Patent Classification⁷: **A61F 2/06** Bjaeverskov (DK). **COOK INCORPORATED** [US/US]; 750 North Daniel's Way, P.O. Box 489, Bloomington, IN 47402-0489 (US).
- (21) International Application Number: PCT/US2004/010445
- (22) International Filing Date: 5 April 2004 (05.04.2004)
- (25) Filing Language: English
- (26) Publication Language: English
- (30) Priority Data:
60/460,291 3 April 2003 (03.04.2003) US
60/510,244 10 October 2003 (10.10.2003) US
- (71) Applicants (for all designated States except US): **WILLIAM A. COOK AUSTRALIA PTY. LTD.** [AU/AU]; 12 Electronics Street, Brisbane Technology Park, Eight Mile Plains, QLD 4113 (AU). **WILLIAM COOK EUROPE ApS** [DK/DK]; Sandet 6, DK-4632
- (72) Inventors; and
- (75) Inventors/Applicants (for US only): **HARTLEY, David, Ernest** [AU/AU]; 2 View Street, Subiaco, WA (AU). **LAWRENCE-BROWN, Michael** [AU/AU]; 36 Shann Street, Floreat, W.A. 6014 (AU). **STELTER, Wolfe** [DE/DE]; Talstrasse 1, 65812 Bad Soden (DE). **IVANCEV, Krasnodar** [SE/SE]; Bredg. 9 B, S-222 21 Lund (SE). **VERHOEVEN, Eric** [NL/NL]; Martinikerhof 6, 9712 JG Groningen (NL).
- (74) Agent: **GODLEWSKI, Richard, J.**; P.O. Box 2269, Bloomington, IN 4740-2269 (US).
- (81) Designated States (unless otherwise indicated, for every kind of national protection available): AE, AG, AL, AM, AT, AU, AZ, BA, BB, BG, BR, BW, BY, BZ, CA, CH, CN, CO, CR, CU, CZ, DE, DK, DM, DZ, EC, EE, EG, ES, FI,

[Continued on next page]

(54) Title: BRANCH STENT GRAFT DEPLOYMENT AND METHOD

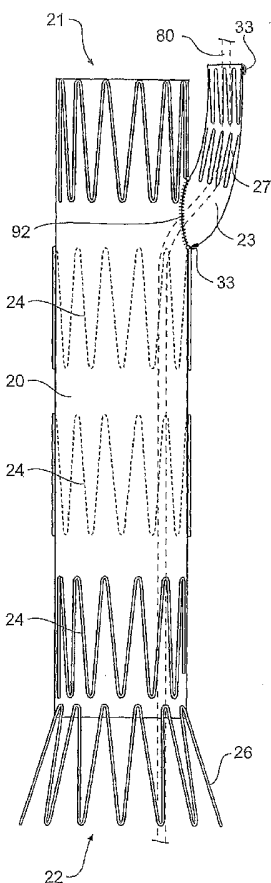

(57) Abstract: A deployment system for introducing stent grafts which have a side arm or into which a side arm can be deployed. For instance the stent graft can be deployed into the thoracic arch of a patient. The deployment system including an introducer (1), an auxiliary catheter (13) disposed within the introducer and an auxiliary guide wire (14) disposed within the auxiliary catheter. The auxiliary guide wire extends to adjacent the proximal end (6) of the introducer and can be extended from the proximal end of the introducer so that it can be snared from a side branch artery (56) to assist with deployment of a side arm (23) of the stent graft into the side artery or for the deployment of a side arm stent graft into the stent graft.

WO 2004/089249 A1



GB, GD, GE, GH, GM, HR, HU, ID, IL, IN, IS, JP, KE, KG, KP, KR, KZ, LC, LK, LR, LS, LT, LU, LV, MA, MD, MG, MK, MN, MW, MX, MZ, NA, NI, NO, NZ, OM, PG, PH, PL, PT, RO, RU, SC, SD, SE, SG, SK, SL, SY, TJ, TM, TN, TR, TT, TZ, UA, UG, US, UZ, VC, VN, YU, ZA, ZM, ZW.

(84) Designated States (unless otherwise indicated, for every kind of regional protection available): ARIPO (BW, GH, GM, KE, LS, MW, MZ, SD, SL, SZ, TZ, UG, ZM, ZW), Eurasian (AM, AZ, BY, KG, KZ, MD, RU, TJ, TM), European (AT, BE, BG, CH, CY, CZ, DE, DK, EE, ES, FI, FR, GB, GR, HU, IE, IT, LU, MC, NL, PL, PT, RO, SE, SI, SK,

TR), OAPI (BF, BJ, CF, CG, CI, CM, GA, GN, GQ, GW, ML, MR, NE, SN, TD, TG).

Published:

- with international search report
- before the expiration of the time limit for amending the claims and to be republished in the event of receipt of amendments

For two-letter codes and other abbreviations, refer to the "Guidance Notes on Codes and Abbreviations" appearing at the beginning of each regular issue of the PCT Gazette.

BRANCH STENT GRAFT DEPLOYMENT AND METHOD

Description

Technical Field

This invention relates to an endoluminal deployment system, a stent graft for endoluminal deployment and a method of endoluminal deployment of such a stent graft into a vessel with a side branch such as the thoracic arch of a patient.

Background of the Invention

The invention is particularly directed towards deploying a stent graft with a fenestration from which or into which a side arm can be deployed to enter one of the arteries that extends from the thoracic arch. These arteries are the innominate artery, the left carotid artery and the left subclavian artery. The invention will generally be discussed in relation to an endoluminal deployment system to enable branch grafting into the left subclavian artery but the invention may equally apply to the other arteries or to other vessels in the human or animal body.

Throughout this specification the term distal with respect to a portion of the aorta, a deployment device or a prosthesis is the end of the aorta, deployment device or prosthesis further away in the direction of blood flow away from the heart and the term proximal means the portion of the aorta, deployment device or end of the prosthesis nearer to the heart. When applied to other vessels similar terms such as caudal and cranial should be understood.

Summary of the Invention

In one form therefore the invention is said to reside in a deployment system for a stent graft to be deployed into an internal lumen of a patient, the deployment system comprising an introducer with the stent graft retained thereon, the introducer having a proximal end intended to be deployed within a patient in use and a distal end intended to remain outside the patient and an auxiliary guide wire, the auxiliary guide wire extending to adjacent the proximal end of the introducer whereby the auxiliary guide wire can be extended from the proximal end of the introducer so that it can be snared from a side artery to assist with deployment of a stent graft into the side artery.

- 2 -

Preferably the introducer includes a sheath to retain the stent graft in a retracted state on the introducer.

The stent graft may be of a type which includes a side branch and the auxiliary guide wire extends through the side branch. Alternatively the stent graft can include a fenestration and the auxiliary guide wire extends through the fenestration. The fenestration can include a graft tube extending into the stent graft from the fenestration either distally or proximally.

The auxiliary guide wire can be retained in an auxiliary catheter extending to the distal end of the introducer, and the auxiliary guide wire can extend out between a nose cone on the proximal end of the introducer and a sheath on the introducer.

There may be provided a retention arrangement for the stent graft on the introducer which is adapted to retain the proximal and distal ends of the stent graft onto the introducer and includes trigger wires and trigger wire release mechanisms to release the proximal and distal retention arrangements.

Diameter reducing ties with an associated trigger wire and trigger wire release mechanisms can be used for the side arm stent graft, the diameter reducing ties being used to hold the diameter of the side arm reduced against the force of self expanding stents in the side arm so that it can be drawn into the side branch artery without unduly engaging the walls of the artery.

In a further form deployment device for deploying a branched stent graft in a thoracic arch of a patient, the stent graft being of a type having a main tubular body with a main lumen therethrough and a side arm with a side arm lumen extending therethrough, the deployment device including a main guide wire catheter extending from a proximal end to a distal end, a nose cone at the proximal end of the guide wire catheter an auxiliary guide wire catheter with an auxiliary guide wire extending therethrough extending from the distal end to the nose cone, the stent graft being retained on the main guide wire catheter distally of the nose cone with the main guide wire passing through the main lumen and the auxiliary guide wire extending through the main lumen and the side arm lumen and extending to the nose cone and the side branch being retained on the auxiliary

guide wire catheter and a sheath coaxial with the main guide wire catheter and extending to the nose cone and enclosing the stent graft.

Preferably the stent graft and side arm on the stent graft include self-expanding stents and a tubular biocompatible graft.

In a further form the invention is said to reside in a deployment device for deploying a fenestrated stent graft in a thoracic arch of a patient, the stent graft being of a type having a main tubular body with a main lumen therethrough and a fenestration in the tubular body, the deployment device including a main guide wire catheter extending from a proximal end to a distal end, a nose cone at the proximal end of the guide wire catheter, an auxiliary catheter with an auxiliary guide wire extending therethrough extending from the distal end to the nose cone, the stent graft being retained on the main guide wire catheter distally of the nose cone with the main guide wire passing through the main lumen and the auxiliary catheter extending through the main lumen and the fenestration and further extending to the nose cone and a sheath coaxial with the main guide wire catheter and extending to the nose cone and enclosing the stent graft.

Preferably the stent graft is retained on the main guide wire catheter with the side arm extending proximally from its connection point with the main tubular body. Hence when advancing the side arm into the side branch artery the introducer with the stent graft retained on it is advanced proximally to allow the side arm to enter the side branch artery.

The stent graft and side arm on the stent graft may include self-expanding stents and a tubular biocompatible graft material covering the stents. The proximal stent may include barbs. There may also be provided at the distal end of the stent graft a distally extending uncovered self expanding stent with barbs to retain the distal end of the stent graft in the aorta. Alternatively the stent graft may be a proximal portion of a composite stent graft and the distal end of the stent graft can be adapted to be connected to or into another stent graft.

The stent graft may have a diameter of from 30 to 40 mm and a length of from 100 to 200 mm. The side arm may have a diameter of 10 to 15 mm and a length of from 20 to 50 mm. The self expanding stents in the main body of the graft

- 4 -

and in the side arm may be Gianturco self expanding zigzag Z stents made from, for example, nitinol or stainless steel.

The deployment device may include a Y branch on the distal end thereof with the auxiliary guide wire catheter extending out of the Y branch. There can be provided a locking arrangement to fix the auxiliary guide wire with respect to the auxiliary guide wire catheter. Alternatively the auxiliary catheter can extend from the distal end of the handle.

In a further form the invention is said to reside in a method of introducing a fenestrated stent graft into the thoracic arch of a patient such that a stent graft can be deployed into the fenestration from the branch artery in the thoracic arch, the method including the steps of;

- (a) introducing an introducer via a femoral artery so that the fenestration is adjacent the branch artery to be grafted,
- (b) extending an auxiliary guide wire from the introducer,
- (c) snaring the auxiliary guide wire from the branch artery by means of a snare catheter introduced via a brachial artery and drawing the auxiliary guide wire into the brachial artery,
- (d) withdrawing the sheath from the introducer,
- (e) advancing a side arm stent graft on a side arm introducer over the auxiliary guide wire into the fenestration,
- (f) releasing the distal and proximal ends of the stent graft, and
- (g) releasing the side arm stent graft from the side arm introducer.

In a further form the invention is said to reside in a method of introducing a branched stent graft into the thoracic arch of a patient such that the branch of the stent graft is deployed into the branch artery in the thoracic arch, the method including the steps of;

- (a) introducing an introducer via a femoral artery to adjacent the branch artery to be grafted,
- (b) extending an auxiliary guide wire from the introducer,
- (c) snaring the auxiliary guide wire from the branch artery by means of a snare catheter introduced via a brachial artery and drawing the auxiliary guide wire into

- 5 -

the brachial artery,

(d) inserting an artery wall protecting sleeve or catheter over the auxiliary guide wire via the brachial artery and clamping it to the auxiliary guide wire,

(e) withdrawing the sheath from the introducer,

(f) advancing the introducer proximally and drawing the side arm into the side branch artery using the artery wall protecting sleeve or catheter and the auxiliary guide wire,

(g) releasing the distal and proximal ends of the stent graft,

(h) releasing the diameter reducing ties on the side arm in the side branch artery, and

(i) removing the introducer.

If necessary and depending upon the size of the aneurysm in the thoracic arch after deployment of the stent graft an extension stent graft may be deployed intra-luminally via the branch artery to connect into the side arm.

In the case of grafting into the left subclavian artery the branch artery into which the snare catheter can be introduced is the brachial artery in the left arm.

U.S. Patent No. 5,387,235 entitled "Expandable Transluminal Graft Prosthesis For Repair Of Aneurysm" discloses apparatus and methods of retaining grafts onto deployment devices. These features and other features disclosed in U.S. Patent No. 5,387,235 could be used with the present invention and the disclosure of U.S. Patent No. 5,387,235 is herewith incorporated in its entirety into this specification.

U.S. Patent No. 5,720,776 entitled "Barb and Expandable Transluminal Graft Prosthesis For Repair of Aneurysm" discloses improved barbs with various forms of mechanical attachment to a stent. These features and other features disclosed in U.S. Patent No. 5,720,776 could be used with the present invention and the disclosure of U.S. Patent No. 5,720,776 is herewith incorporated in its entirety into this specification.

PCT Patent Publication Number WO98/53761 entitled "A Prosthesis and a Method of Deploying a Prosthesis" discloses an introducer for a prosthesis which retains the prosthesis so that each end can be moved independently. These

features and other features disclosed in PCT Patent Publication Number No. WO98/53761 could be used with the present invention and the disclosure of PCT Patent Publication Number No. WO98/53761 is herewith incorporated in its entirety into this specification.

PCT Patent Publication No. WO 03/034948 entitled "Prosthesis For Curved Lumens" discloses prostheses with arrangements for bending the prosthesis for placement into curved lumens. This feature and other features disclosed in PCT Patent Publication No. WO 03/034948 could be used with the present invention and the disclosure of PCT Patent Publication No. WO 03/034948 is herewith incorporated in its entirety into this specification.

US Patent No. 6,206,931 entitled "Graft Prosthesis Materials" discloses graft prosthesis materials and a method for implanting, transplanting replacing and repairing a part of a patient and particularly the manufacture and use of a purified, collagen based matrix structure removed from a submucosa tissue source. These features and other features disclosed in US Patent No. 6,206,931 could be used with the present invention and the disclosure of US Patent No. 6,206,931 is herewith incorporated in its entirety into this specification.

Australian Provisional Patent Application N PS3215 entitled "A Stent-Graft Fastening Arrangement", and US Patent Application 10/602,930, filed June 24, 2003 entitled "Stent-Graft Fastening", and PCT Patent Publication Number WO 2004/002365 disclose arrangements for fastening stents onto grafts particularly for exposed stents. This feature and other features disclosed in Australian Provisional Patent Application Number No. PS3215 and US Patent Application 10/602,930, filed June 24, 2003, and PCT Patent Publication Number WO 2004/002365 could be used with the present invention and the disclosure of Australian Provisional Patent Application Number PS3215 and US Patent Application 10/602,930, filed June 24, 2003, and PCT Patent Publication Number WO 2004/002365 is herewith incorporated in its entirety into this specification.

Australian Provisional Application Number PR9617 entitled "Improving Graft Adhesion", and U.S. Patent Application Publication No. US2003-0120332 and PCT Patent Publication Number No. WO03/053287 entitled "Stent Graft With

Improved Adhesion" disclose arrangements on stent grafts for enhancing the adhesion of such stent grafts into walls of vessels in which they are deployed. This feature and other features disclosed in Australian Provisional Application Number PR9617, U.S. Patent Application Publication No. US2003-0120332, and PCT Patent Publication Number No. WO03/053287 could be used with the present invention and the disclosure of Australian Provisional Application Number PR9617, U.S. Patent Application Publication No. US2003-0120332, and PCT Patent Publication Number No. WO03/053287 is herewith incorporated in its entirety into this specification.

Brief Description of the Drawing

This then generally describes the invention but to assist with understanding reference will now be made to the enclosed drawings which show a preferred embodiment of the device and the method of deploying the graft using the device.

In the drawings:

Figure 1 shows an embodiment of an introducer device according to this invention;

Figure 2 shows an alternative embodiment of an introducer device according to this invention;

Figure 3 shows detail of the proximal end of the introducer device according to either Figure 1 or Figure 2;

Figure 4 shows a longitudinal cross-sectional view of the proximal end introducer device shown in Figure 3 and showing one embodiment of stent graft retained therein;

Figure 5 shows a transverse cross-sectional view of a side arm of a stent graft suitable for the invention particularly showing a diameter reducing tie arrangement;

Figure 6 shows an embodiment of a stent graft suitable for the present invention;

Figure 7 shows an alternative embodiment of a stent graft suitable for the present invention;

Figure 8 shows an alternative embodiment of a stent graft suitable for the

present invention;

Figure 9 shows an alternative embodiment of a stent graft suitable for the present invention;

Figure 10 shows a schematic view of the first stage of deployment of the introducer device shown in Figure 1 or Figure 2 and including a stent graft as shown in Figure 9 into a thoracic arch of a patient;

Figure 11 shows a second stage in the process with the auxiliary guide wire snared;

Figure 12 shows a further stage with a protective catheter passed over auxiliary guide wire;

Figure 13 shows a further stage with the sheath on the deployment device withdrawn partially;

Figure 14 shows the next stage of deployment with the side arm drawn into the subclavian artery;

Figure 15 shows the first stage of release of the stent graft from the introducer device;

Figure 16 shows the second stage of release of the stent graft from the introducer device;

Figure 17 shows the final stage of release of the stent graft from the introducer:

Figure 18 shows a schematic and detailed view of the deployment of a stent graft of a type as shown in Figure 8 into a thoracic arch of a patient;

Figure 19 shows a detailed view of the deployment of a stent graft of a type as shown in Figure 6 into a thoracic arch of a patient; and

Figure 20 shows a detailed view of the deployment of a stent graft of a type as shown in Figure 7 into a thoracic arch of a patient.

Detailed Description

Now looking more closely at the drawings and in particular Figures 1 to 5 which show preferred embodiments of deployment devices or introducers according to the invention. In each case the same reference numerals will be used for corresponding components or parts.

- 9 -

It will be seen that the endoluminal deployment device generally comprises an introducer 1a comprising a deployment catheter 1 with a handle 2 at the distal end generally shown as 4. Covering a portion of the deployment catheter 1 is a sheath 3 extending proximally from a sheath manipulator 7.

At the proximal end 6 of the introducer 1a is a nose cone 8. The nose cone is fastened to the guide wire catheter 9 which extends from the distal end 4 of the introducer device to the nose cone. A guide wire 11 extends through the guide wire catheter 9. A pin vice 10 locks the guide wire catheter with respect to the deployment catheter 1 at the distal end 2a of the handle 2.

In the embodiment shown in Figure 1, proximally of the handle 2 is a "Y" piece 15 in the deployment catheter 1 with a side arm 16 extending from the "Y" piece. Extending through the side arm 16 and through a seal 17 is an auxiliary catheter 13 with an auxiliary guide wire 14 through the auxiliary catheter 13. A grip and syringe adaptor 12 at the distal end of the auxiliary catheter 13 enables connection of a syringe to flush the auxiliary catheter 13 as required.

In the embodiment shown in Figure 2, an auxiliary catheter 13 with an auxiliary guide wire 14 extending through the auxiliary catheter 13 extends from the distal end 2a of the handle 2. A grip and syringe adaptor 12 at the distal end of the auxiliary catheter 13 enables connection of a syringe to flush the auxiliary catheter 13 as required.

On the handle 2 is mounted a set of trigger wire release arrangements generally shown as 18 which will be discussed in detail later.

It will be noted that the nose cone 8 has, as particularly shown in Figure 4, a longitudinal notch 28 through which passes the auxiliary catheter 13 and auxiliary guide wire 14 so that it extends just beyond the sheath 3. This means that once the introducer has been deployed in substantially the correct position the auxiliary guide wire 14 can be advanced beyond the nose cone 8 so that it can be snared from the side branch artery as will be discussed later.

As can also be seen separately in various embodiments in Figures 6 to 10 and in a compressed condition partially in Figure 3 there is a stent graft 20 which is retained under the sheath 3 in the region 19 on the introducer.

The stent graft 20 has a substantially tubular body with a lumen through it and with a proximal end 21 and a distal end 22. Four different embodiments of stent graft may be applicable to the present invention and these are shown in Figures 6 to 9. The embodiment shown in Figure 9 is partially shown in a compressed condition on the deployment device in Figure 4. Extending substantially laterally from the tubular body 20 and nearer the proximal end 21 is a side arm 23 again with a lumen through it which is continuous with the lumen of the tubular body 20. As can be particularly seen in Figure 4 when the stent graft 20 is in a compressed state within the sheath 3, the side arm 23 is directed proximally.

As seen in Figure 9, the stent graft 20 has zig zag style Gianturco Z stents 24 along its length with a distally extending uncovered zig zag style Gianturco Z stent 26. It should be noted that in some embodiments of the stent graft for placement in the thoracic arch the distally extending uncovered zig zag style Gianturco Z stent 26 may not be present. The side arm 23 also has zig zag Gianturco Z stents 27. The stents are inside the stent graft 20 at the proximal and distal ends and outside the stent graft 20 between the proximal and distal ends. The number of zig zag Gianturco Z stents along the length of the tubular graft 20 will depend upon the length of the stent graft 20.

As can be seen in Figure 4 and in detail in Figure 5 the side arm 23 is held in a diameter reduced condition for deployment by means of diameter reducing ties 29. The diameter reducing ties 29 are lengths of suture material which are fastened to the graft material at 30 and are looped around a trigger wire 31 on the opposite side of the side arm and pulled tight so that the diameter of the side arm is reduced. When the trigger wire 31 is released as will be discussed later, the loops of the diameter reducing ties are released and the side arm can expand to its full size. After release the diameter reducing ties remain fixed to the graft material of the side arm.

The auxiliary catheter includes a bulge or "acorn" 44 where it passes through the side arm 23 with extra diameter reducing ties 46 either side of it. These diameter reducing ties 46 effectively grip the auxiliary guide wire catheter either side of the bulge or "acorn". By this arrangement the auxiliary catheter cannot be

- 11 -

moved with respect to the side arm unless the diameter reducing ties 46 are removed. This facilitates the moving of the side arm by preventing relative movement of the side arm with respect to the auxiliary catheter 12. The extra diameter reducing ties 46 can be released by the same trigger wire 31 that is used to release the diameter reducing ties 29.

Also on the side arm 23 are radio-opaque markers 33 which enable the position of the side arm to be observed by suitable radio-graphic techniques.

The proximal end 21 of the stent graft 20 is retained in a compressed condition and attached to the guide wire catheter 9 by a release arrangement 35 and a trigger wire 36 to release the release arrangement 35 is also present. Such a retention and release arrangement is depicted in PCT Publication WO 2004/017868 and the disclosure of this patent specification is incorporated in its entirety herein and for all purposes

A further trigger wire release arrangement (not shown in Figure 4) is used to retain the distal end of the stent graft at the proximal end of the deployment catheter 1. This distal release arrangement may include a capsule for the exposed stent 26 (see Figure 9). Such a capsule system is depicted in PCT Publication WO 98/53716. The use of a distal capsule system and a deployment system to release an exposed stent is described in United States of America Provisional Patent Application Serial No 60/392,667 and the disclosures of those patent specifications are incorporated in their entirety herein and for all purposes.

It will be noted that the auxiliary catheter 13 and the auxiliary guide wire 14 pass through the lumen of the stent graft 20 as well as the lumen of the side arm 23 and then out through the notch 28 in the nose cone 8.

The trigger wire release arrangements 18 on the handle 2 includes three trigger wire release mechanisms. A first trigger wire release mechanism 40 is used to release the distal stent graft release mechanism via trigger wire 37, a second trigger wire release mechanism 41 is used to release the proximal end stent graft release mechanism 35 via trigger wire 36 and the third trigger wire release mechanism 42 is used to pull the trigger wire 31 which releases the diameter reducing ties 29. The trigger wire release mechanisms are operated in the order

discussed as will be explained also later with respect to the various stages of deployment according to one embodiment of the invention. In some embodiments of the invention there may be only two trigger wire release mechanisms such as where the proximal and distal ends of the stent graft are retained by the same trigger wire.

Various embodiments of stent graft suitable for use with the present invention will now be discussed with reference to Figure 6 to 9. In each case the same reference numerals will be used for corresponding components or parts.

Each of the stent grafts 20 has a tubular body of a biocompatible graft material and zig zag style Gianturco Z stents 24 along its length with a distally extending uncovered zig zag style Gianturco Z stent 26. It should be noted that in some embodiments of the stent graft for placement in the thoracic arch the distally extending uncovered zig zag style Gianturco Z stent 26 may not be present. This may be so, for instance, when the stent graft 20 is a proximal portion of a composite stent grafting system. The use of a composite stent grafting system is described in PCT publication WO 2004/017867 and the disclosures of this patent specification is incorporated in its entirety herein and for all purposes.

The stents are inside the stent graft 20 at the proximal and distal ends 21, 22 and outside the stent graft 20 between the proximal end 21 and the distal end 22. The number of zig zag Gianturco Z stents along the length of the tubular graft 20 will depend upon the length of the stent graft 20. Normally the zig zag Gianturco Z stents are spaced apart to allow a degree of flexibility of the stent graft so that it can more easily fit the shape of a vessel into which it is deployed.

In each case the stent graft includes a fenestration but the treatment of the fenestration varies.

In Figure 6 the fenestration 75 has a graft material tube 77 fastened around its periphery and extending within the stent graft and towards the distal end 22. The graft material tube 77 includes an external zig zag Gianturco Z stent 76. When a side arm stent graft is deployed through the fenestration 75 into the graft material tube 77 it is into the region of the external zig zag Gianturco Z stent 76 that sealing occurs. The end 79 of the graft material tube 77 is cut off at an angle and fastened

by stitching 80 to the stent graft wall 20. The size of the fenestration 75 is preferably somewhat larger than the size of the branch vessel to allow for a degree of misalignment. For instance the fenestration may have an oval shape. The dotted line 80 shows how the auxiliary guide wire catheter passes through the graft material tube 77 and fenestration 75.

In Figure 7 the fenestration 85 has a graft material tube 87 fastened around its periphery and extending within the stent graft and towards the proximal end 21. The graft material tube 87 includes an external zig zag Gianturco Z stent 86. When a side arm stent graft is deployed through the fenestration 85 into the graft material tube 87 it is into the region of the external zig zag Gianturco Z stent 86 that sealing occurs. The end 89 of the graft material tube 87 is fastened by stitching 90 to the stent graft wall 20. The size of the fenestration 85 is preferably somewhat larger than the size of the branch vessel to allow for a degree of misalignment. For instance the fenestration may have an oval shape. The fenestration 85 may also have a reinforcement ring of Nitinol or similar resilient wire around its periphery. The dotted line 80 shows how the auxiliary guide wire catheter passes through the graft material tube 87 and fenestration 85. At 88 the auxiliary catheter passes through an aperture in the graft material tube 87 which aperture is preferably self sealing so that after removal of the auxiliary guide wire catheter leakage of blood does not occur. This may be achieved by spreading apart the fibres of the graft material tube to allow the auxiliary catheter to pass through rather than cutting them at 88. Alternatively some form of flap valve may be used.

In an alternative arrangement the auxiliary catheter may have a zig zag configuration and pass up through the stent graft 20 and enter the graft material tube 87 at its end 89 and then exit through the fenestration 85.

In Figure 8 the stent graft 20 merely has a fenestration 70 with a reinforcement ring 73 of Nitinol or similar resilient wire around its periphery. When a side arm stent graft is deployed through the fenestration into the stent graft 20 sealing occurs around the periphery of the fenestration. The size of the fenestration 70 is preferably slightly smaller than the size of the side arm stent graft to be placed into the branch vessel to allow for sealing. In this embodiment stent graft 20

- 14 -

includes a scalloped end 71 to allow the stent graft to be placed over the adjacent carotid artery. Such a scalloped end may also be used with the other embodiments of stent graft. The dotted line 80 shows how the auxiliary guide wire catheter passes through the stent graft 20 and fenestration 75.

In Figure 9 the fenestration 92 has a graft material tube 23 fastened around its periphery and extending from the stent graft. The fenestration 92 may also have a reinforcement ring of Nitinol or similar resilient wire around its periphery. The graft material tube 23 includes one or more external zig zag Gianturco Z stents 27. The dotted line 80 shows how the auxiliary guide wire catheter passes through the graft material tube 23 and fenestration 92. The side arm 23 includes radio-opaque markers 33 to assist with placement.

The various stages of deployment of one embodiment of the stent graft 20 into the thoracic arch of a patient will now be discussed with reference to Figures 10 to 17. The deployment device can be the type shown in either Figure 1 or Figure 2.

The thoracic arch region of a patient generally comprises an ascending aorta 50 extending from an aortic valve 51 of the heart of the patient, then over the thoracic arch 52 to the descending aorta 53. From the thoracic arch three main arteries extend. These are the innominate artery 54, the left carotid artery 55 and a subclavian artery 56. This embodiment of the invention will generally be discussed with reference to deployment of a stent graft with a side branch into the aorta and left subclavian artery but the invention is not so restricted.

A stent graft may be necessary in the aortic arch region when an aneurysm 57 in the aorta extends up the aorta to such an extent that there is insufficient patent aortic wall to provide good sealing for a stent graft distally of the left subclavian artery 56. It is desirable in such circumstances to extend the stent graft to seal onto good artery wall at least between the left carotid artery 55 and the left subclavian artery 56.

The invention is not limited to this particular application but will be discussed in relation to this particular application.

As can be seen in Figure 10 the introducer 1a has been introduced into the

- 15 -

aorta normally via an incision into the femoral artery over a guide wire 11. The guide wire 11 has been deployed down towards the aortic valve 51. Once the introducer is in position the auxiliary guide wire 14 is extended beyond the nose cone 8 of the introducer until it is adjacent the left subclavian artery. A suitable radio-graphic tip may be provided on the guide wire to assist with determination of its location.

An incision can then be made into the brachial artery of the left arm and a snare catheter 60 introduced into the brachial artery and via that to the left subclavian artery and this snare catheter has a loop 61 at its end which can then be used to snare the guide wire 14. The snare is used to grip and pull the flexible guide wire 14 into the left subclavian artery and out through the brachial artery.

In the next stage shown in Figure 11 the introducer 1a is advanced proximally over the guide wire 11 with the auxiliary guide wire 14 still extending into the left subclavian artery. The introducer is advanced until the nose cone is adjacent the left subclavian artery and the sheath 3 is just distal of the opening of the artery into the thoracic arch.

As can be seen in Figure 12 a protective catheter or sleeve 62 is deployed onto the auxiliary guide wire where it exits from the brachial artery and is then slid over the auxiliary guide wire 14 from the brachial artery end to protect the junction 57 of the left subclavian artery with the thoracic arch during the subsequent steps. The protective catheter or sleeve 62 and the auxiliary guide wire 14 are then locked together so that they can be used to pull the side arm 23 of the stent graft into the left subclavian artery 56.

As can be seen in Figure 13 the sheath 3 of the introducer 1a has been partially withdrawn so that the stent graft 20 retained by the sheath 3 has expanded but the retention arrangement 35 still holds the proximal end 21 of the graft in a restrained condition. The side arm 23 is also released from the sheath but still held in a retracted condition by diameter reducing ties 29. It will be noted that at this stage the distal end 22 of the stent graft is still retained within the sheath 3.

As shown in Figure 14, the introducer 1a is then moved further proximally while pulling on the protection catheter 62 and guide wire 14 so that the side arm

23 of the stent graft 20 is pulled into the left subclavian artery 56.

As shown in Figure 15 the sheath 3 is then pulled further back so that the distal end of the graft 20 is released from the sheath 3 and then the distal trigger wire release mechanism 40 (see Figure 1) can be released to release the external zig zag stents 26 so that they expand against the wall of the descending aorta 53.

Next as shown in Figure 16 the proximal end 21 of the graft 20 is released by releasing the retention mechanism 35 (see Figure 1) by pulling on the trigger wire release mechanism 41 which pulls out trigger wire 36.

Finally as shown in Figure 17 the diameter reducing ties are released by pulling on the trigger wire release mechanism 42 (see Figure 1) which pulls the trigger wire 31.

The auxiliary guide wire 14 can then be retracted into the introducer 1a and the introducer removed from the aorta to leave the stent graft 20 deployed in the aorta with the side arm 23 deployed into the left subclavian artery 56.

Figure 18 shows a schematic and a detailed view of the deployment of a stent graft as shown in Figure 8 into a thoracic arch of a patient. After the introducer is deployed into the thoracic arch and the auxiliary guide wire snared as shown in Figures 10 and 11 the introducer is further advanced proximally over the main guide wire 11 until the fenestration 70 (see also Figure 8) is adjacent the subclavian artery 56. It will be noted that at this stage the scallop 71 at the distal end 21 of the stent graft 20 is positioned around the adjacent carotid artery 55 so as not to occlude it.. This arrangement enables the distal end 21 of the stent graft 20 to have a larger landing zone in the thoracic arch while not occluding the carotid artery. A separate balloon expandable stent graft 72 can then be deployed brachially and through the subclavian artery over the auxiliary guide wire 14 so that its proximal end 74 enters the fenestration 70 and then it can be balloon expanded so that the end 74 is in effect crimped around the fenestration 70 to securely retain the stent graft 72 in the fenestration 70.

Figure 19 shows a detailed view of the deployment of a stent graft as shown in Figure 6 into a thoracic arch of a patient. After the introducer is deployed into the thoracic arch and the auxiliary guide wire snared as shown in Figures 10 and 11 the

- 17 -

introducer is further advanced proximally over the main guide wire 11 (see Figure 11) until the fenestration 75 (see also Figure 6) is adjacent the subclavian artery 56. A separate balloon expandable or self expanding stent graft 94 can then be deployed brachially through the subclavian artery over the auxiliary guide wire 14 so that its proximal end 96 enters the fenestration 75 and then it can be allowed to expand or be balloon expanded so that the end is expanded within the graft material tube 77 to seal the side arm stent graft 94 into the main stent graft 20.

Figure 20 shows a detail view of the deployment of a stent graft as shown in Figure 7 into a thoracic arch of a patient. After the introducer is deployed into the thoracic arch and the auxiliary guide wire snared as shown in Figures 10 and 11 the introducer is further advanced proximally over the main guide wire 11 until the fenestration 85 (see also Figure 7) is adjacent the subclavian artery 56. A separate balloon expandable or self expanding stent graft 98 can then be deployed brachially through the subclavian artery over the auxiliary guide wire 14 so that its proximal end 99 enters the fenestration 75 and then it can be allowed to expand or be balloon expanded so that the end is expanded within the graft material tube 87 to seal the side arm stent graft 98 into the main stent graft 20.

Throughout this specification various indications have been given as to the scope of this invention but the invention is not limited to any one of these but may reside in two or more of these combined together. The examples are given for illustration only and not for limitation.

Throughout this specification and the claims that follow unless the context requires otherwise, the words 'comprise' and 'include' and variations such as 'comprising' and 'including' will be understood to imply the inclusion of a stated integer or group of integers but not the exclusion of any other integer or group of integers.

Claims

1. A deployment system for a stent graft to be deployed into an internal lumen of a patient, the deployment system comprising an introducer with the stent graft retained thereon, the introducer having a proximal end intended to be deployed within a patient in use and a distal end intended to remain outside the patient and an auxiliary guide wire, the auxiliary guide wire extending to adjacent the proximal end of the introducer, characterized in that the auxiliary guide wire is configured for extension from the proximal end of the introducer and snaring from a side artery to assist with deployment of the stent graft into the side artery.
2. A deployment system as in Claim 1 characterized in that the introducer includes a sheath to retain the stent graft in a retracted state on the introducer.
3. A deployment system as in Claim 1 characterized in that the stent graft includes a side branch and the auxiliary guide wire extends through the side branch.
4. A deployment system as in Claim 1 characterized in that the stent graft includes a fenestration and the auxiliary guide wire extends through the fenestration.
5. A deployment system as in Claim 4 characterized in that the fenestration includes a side arm stent graft extending from the fenestration.
6. A deployment system as in Claim 4 characterized in that the fenestration includes a graft tube extending into the stent graft from the fenestration.
7. A deployment system as in Claim 6 characterized in that the graft tube extending into the stent graft from the fenestration extends distally.
8. A deployment system as in Claim 6 characterized in that the graft tube extending into the stent graft from the fenestration extends proximally.
9. A deployment system as in Claim 1 characterized in that the auxiliary guide wire is retained in an auxiliary catheter extending to the distal end of the introducer.
10. A deployment system as in Claim 1 characterized in that the auxiliary guide wire extends out between a nose cone on the proximal end of the introducer and a sheath on the introducer.

11. A deployment system as in Claim 1 characterized in that the deployment system further comprises a retention arrangement for the stent graft on the introducer which is adapted to retain the proximal and distal ends of the stent graft onto the introducer and includes trigger wires and trigger wire release mechanisms to release the proximal and distal retention arrangements.

12. A deployment system as in Claim 5 characterized in that there are diameter reducing ties with an associated trigger wire and trigger wire release mechanisms for the side arm stent graft, the diameter reducing ties being used to hold the diameter of the side arm reduced against the force of self expanding stents in the side arm so that it can be drawn into the side branch artery without unduly engaging the walls of the artery.

13. A deployment system as in Claim 1, characterized in that the stent graft has a main tubular body with a main lumen therethrough and a side arm with a side arm lumen extending therethrough, and in that the deployment system includes a main guide wire catheter, extending from a proximal end to a distal end, a nose cone at the proximal end of the guide wire catheter an auxiliary guide wire catheter with an auxiliary guide wire extending therethrough extending from the distal end to the nose cone, the stent graft being retained on the main guide wire catheter distally of the nose cone with the main guide wire passing through the main lumen and the auxiliary guide wire extending through the main lumen and the side arm lumen and extending to the nose cone and the side branch being retained on the auxiliary guide wire catheter and a sheath coaxial with the main guide wire catheter and extending to the nose cone and enclosing the stent graft.

14. A deployment device as in Claim 13 characterized in that the stent graft and side arm on the stent graft include self-expanding stents and a tubular biocompatible graft.

15. A deployment device as in Claim 13 characterized in that the nose cone includes a longitudinal notch to allow the auxiliary catheter to exit the sheath.

16. A deployment device as in Claim 1, characterized in that the stent graft has a main tubular body with a main lumen therethrough and a fenestration in the tubular body, and in that the deployment system includes a main guide wire

catheter extending from a proximal end to a distal end, a nose cone at the proximal end of the guide wire catheter, an auxiliary catheter with an auxiliary guide wire extending therethrough extending from the distal end to the nose cone, the stent graft being retained on the main guide wire catheter distally of the nose cone with the main guide wire passing through the main lumen and the auxiliary catheter extending through the main lumen and the fenestration and further extending to the nose cone and a sheath coaxial with the main guide wire catheter and extending to the nose cone and enclosing the stent graft.

17. A deployment device as in Claim 16 characterized in that the nose cone includes a longitudinal notch to allow the auxiliary catheter to exit the sheath.

18. A deployment system as in Claim 16 characterized in that the fenestration includes a graft tube extending into the stent graft from the fenestration.

19. A method of introducing a fenestrated stent graft into the thoracic arch of a patient such that a stent graft can be deployed into the fenestration from the branch artery in the thoracic arch, the method including the steps of;

(a) introducing an introducer via a femoral artery so that the fenestration is adjacent the branch artery to be grafted,

(b) extending an auxiliary guide wire from the introducer,

(c) snaring the auxiliary guide wire from the branch artery by means of a snare catheter introduced via a brachial artery and drawing the auxiliary guide wire into the brachial artery,

(d) withdrawing the sheath from the introducer,

(e) advancing a side arm stent graft on a side arm introducer over the auxiliary guide wire into the fenestration,

(f) releasing the distal and proximal ends of the stent graft, and

(g) releasing the side arm stent graft from the side arm introducer.

20. A method of introducing a branched stent graft into the thoracic arch of a patient such that the branch of the stent graft is deployed into the branch artery in the thoracic arch, the method including the steps of;

(a) introducing an introducer via a femoral artery to adjacent the branch artery to be grafted,

- 21 -

- (b) extending an auxiliary guide wire from the introducer,
- (c) snaring the auxiliary guide wire from the branch artery by means of a snare catheter introduced via a brachial artery and drawing the auxiliary guide wire into the brachial artery,
- (d) inserting an artery wall protecting sleeve or catheter over the auxiliary guide wire via the brachial artery and clamping it to the auxiliary guide wire,
- (e) withdrawing the sheath from the introducer,
- (f) advancing the introducer proximally and drawing the side arm into the side branch artery using the artery wall protecting sleeve or catheter and the auxiliary guide wire,
- (g) releasing the distal and proximal ends of the stent graft,
- (h) releasing the diameter reducing ties on the side arm in the side branch artery,
and
- (i) removing the introducer.

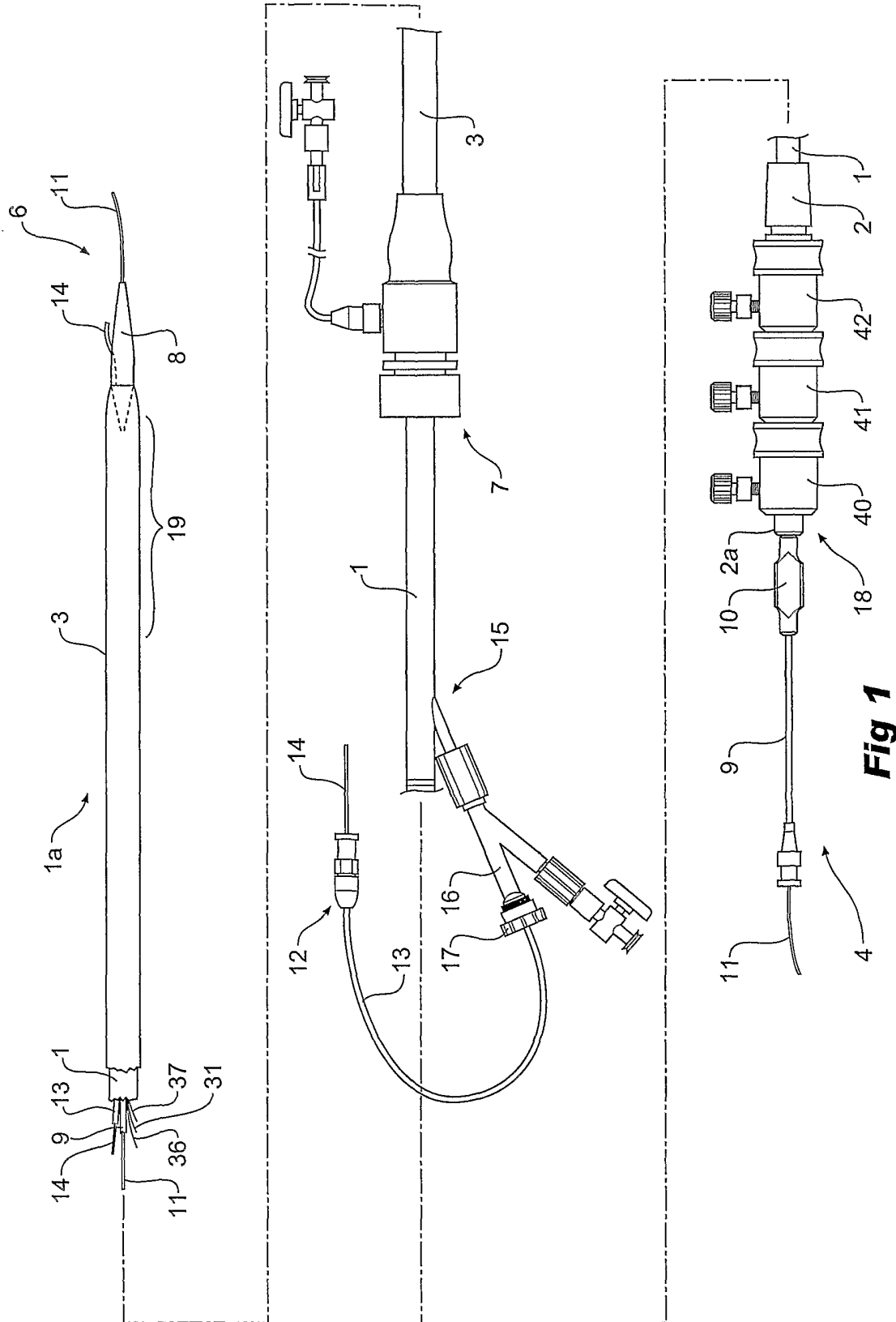

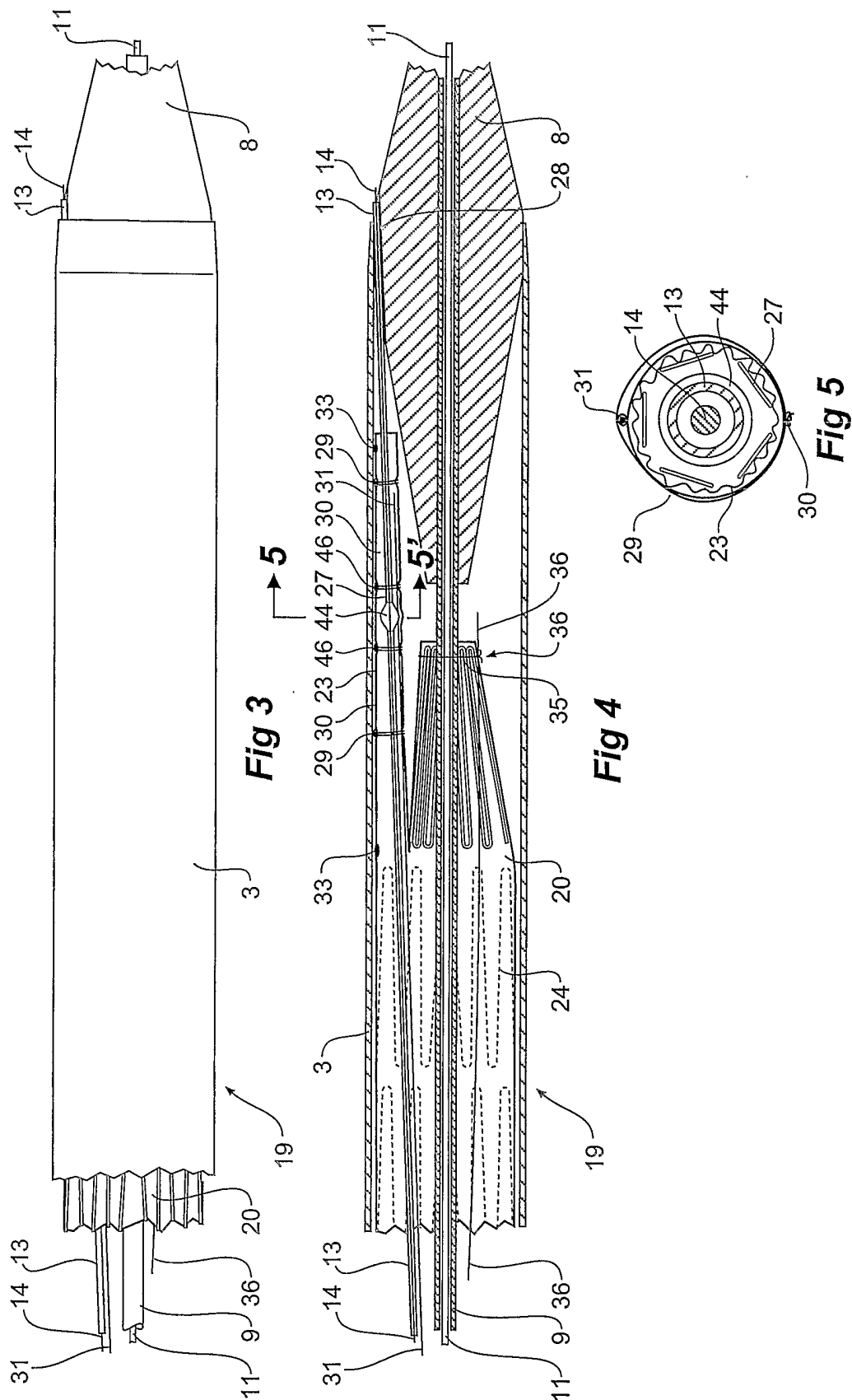

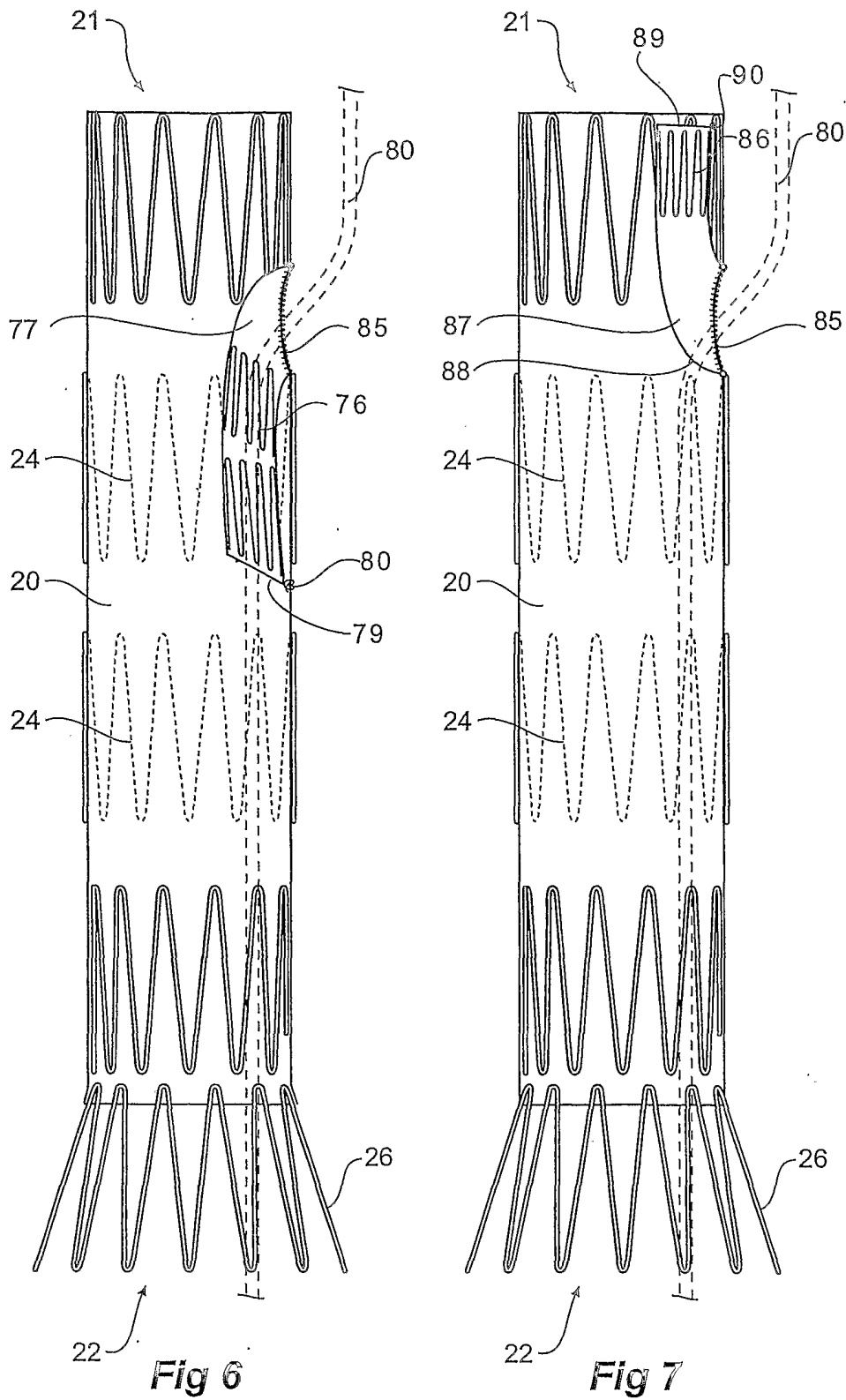

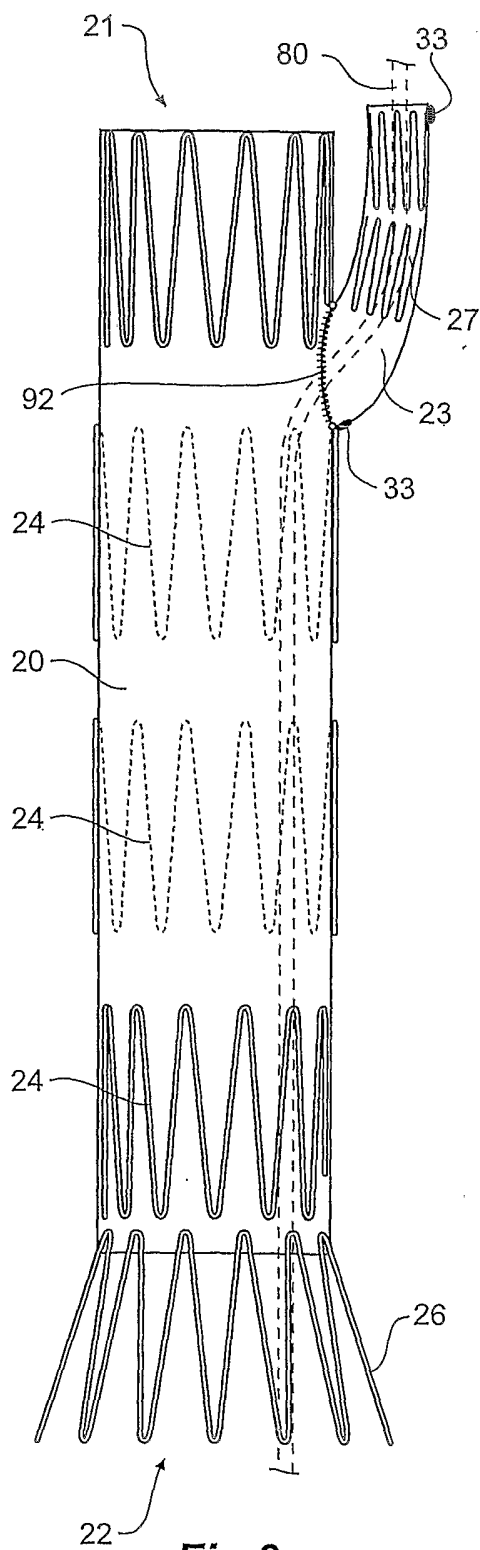
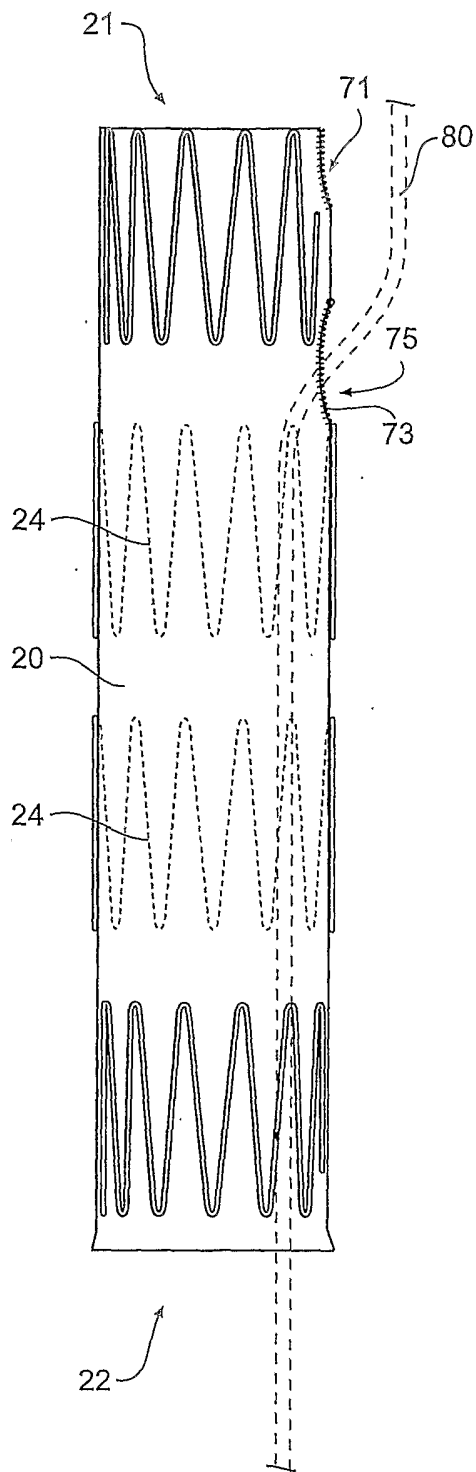

6/15

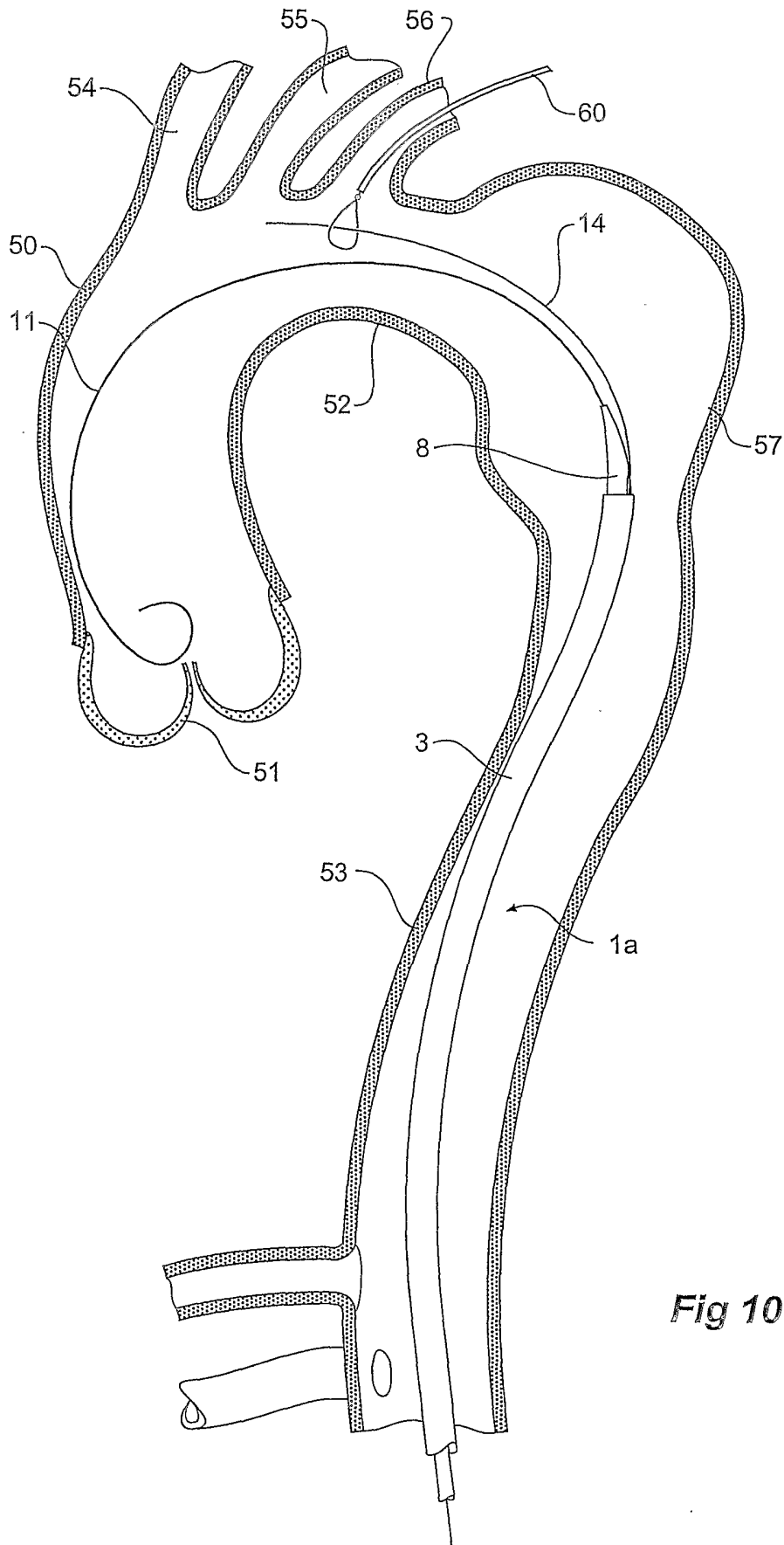

Fig 10

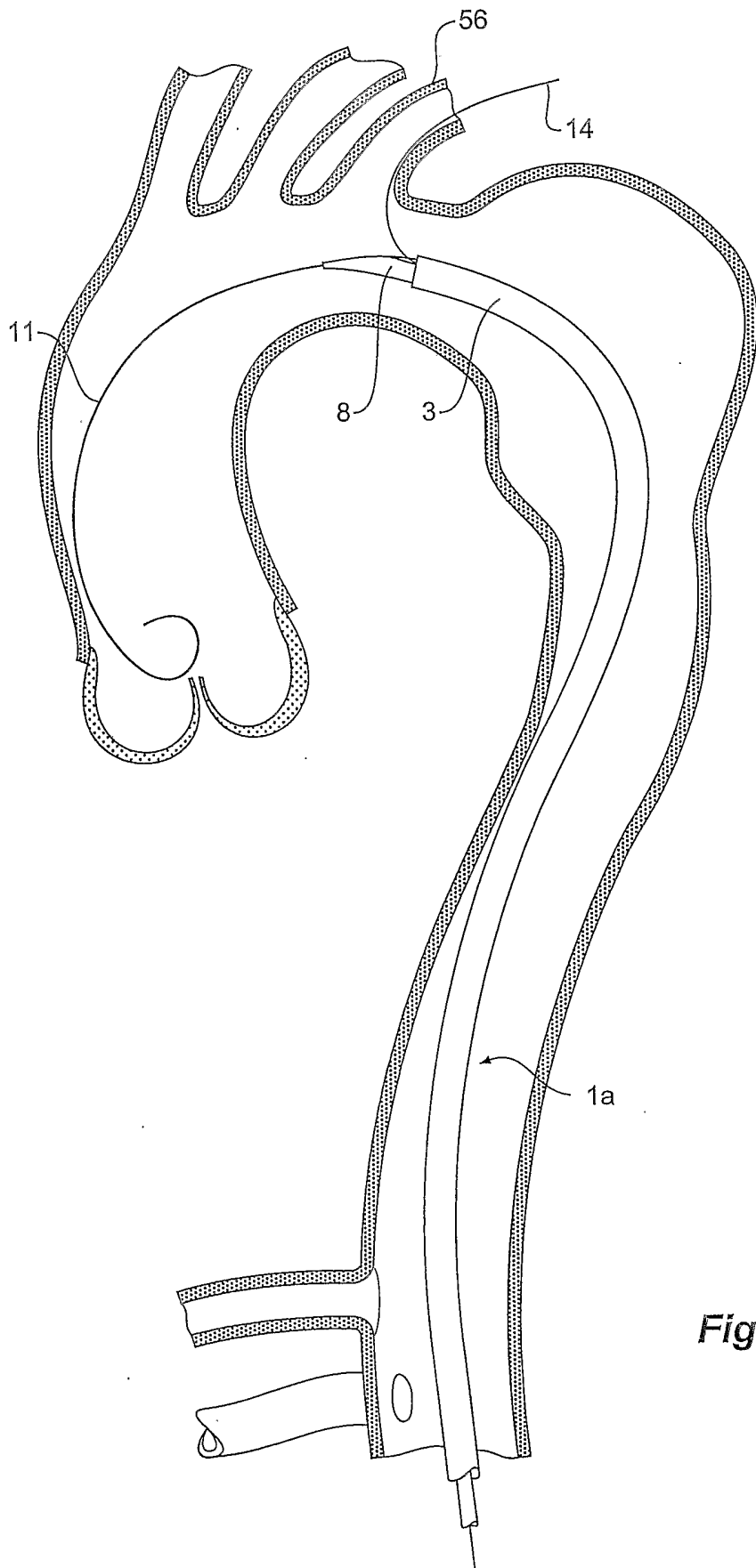

Fig 11

8/15

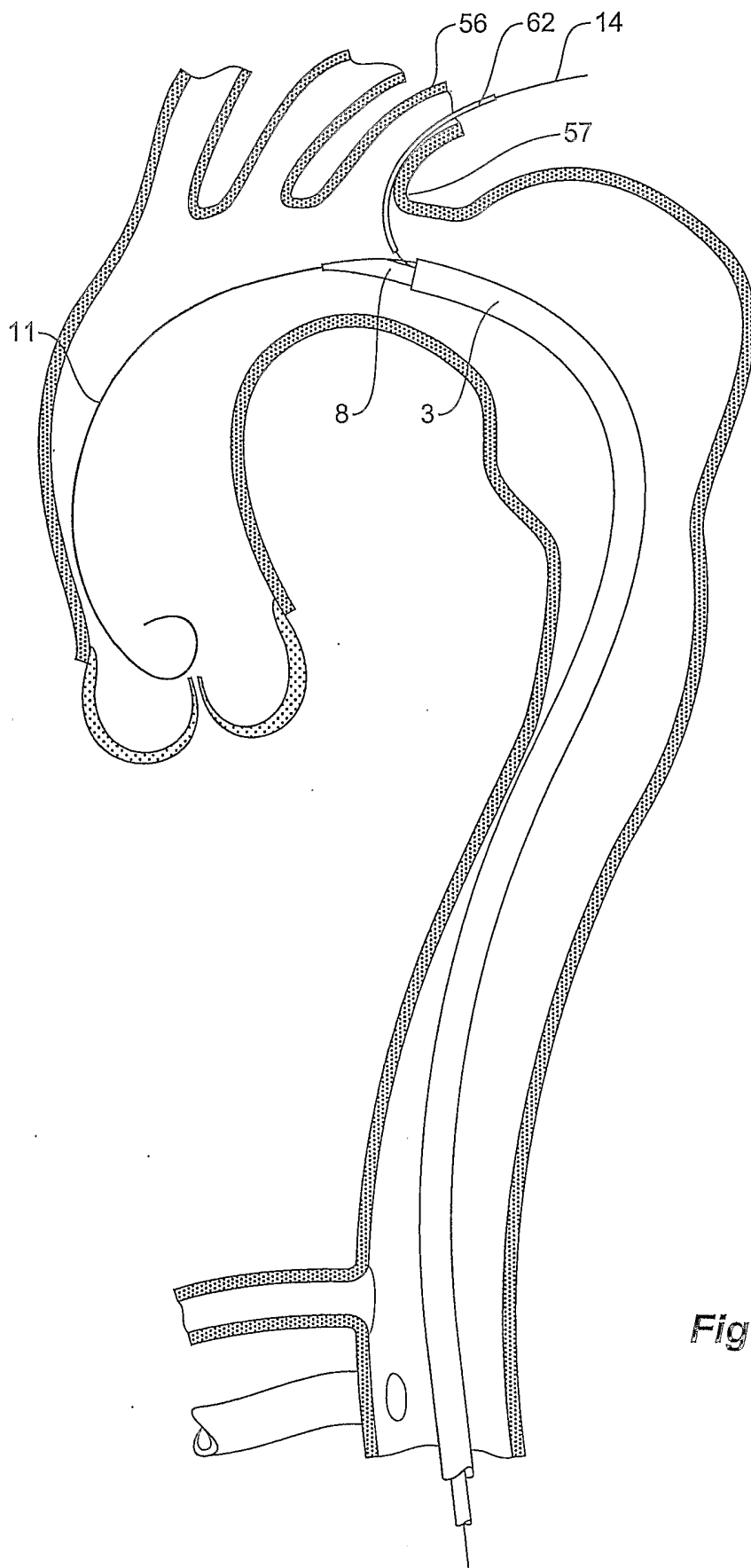

Fig 12

9/15

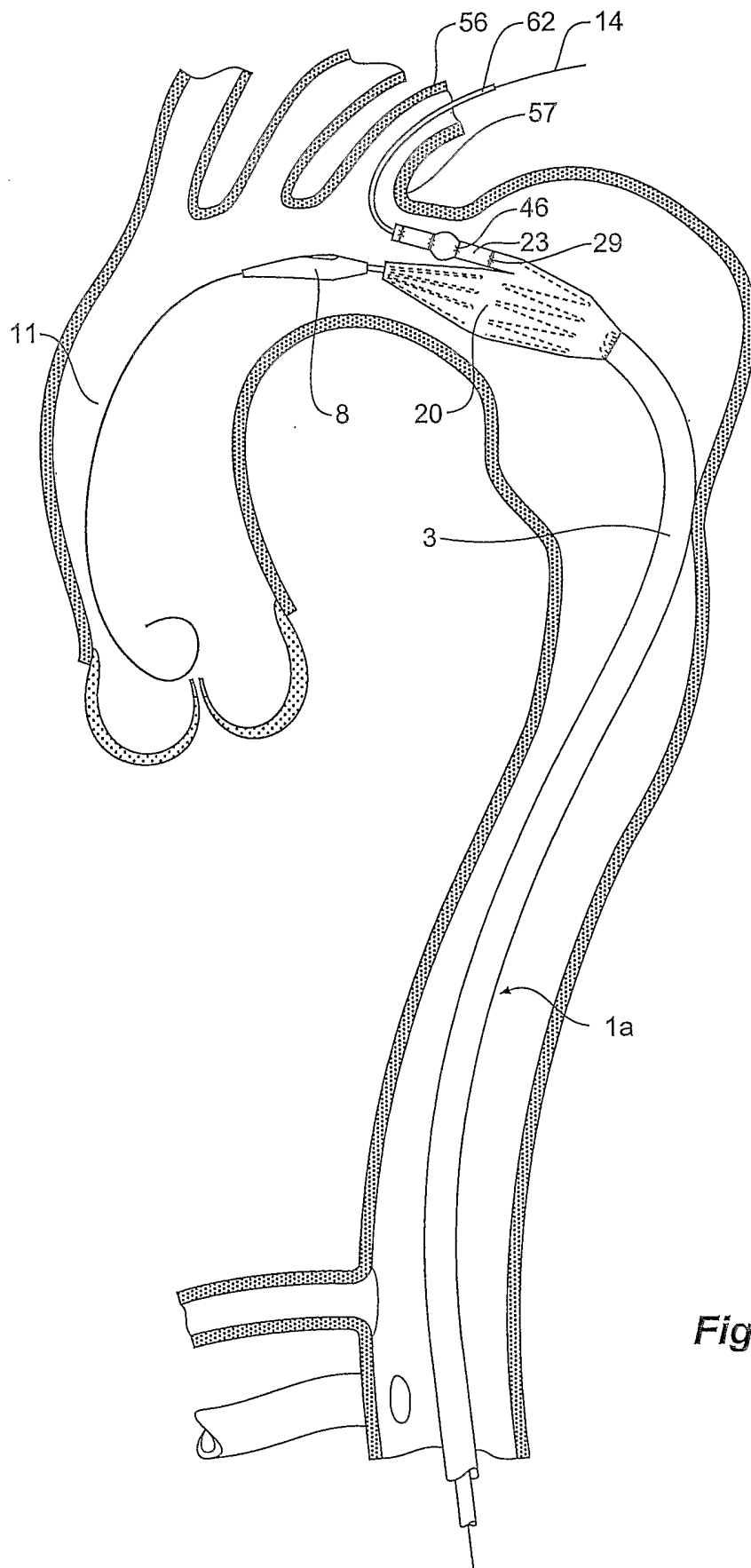

Fig 13

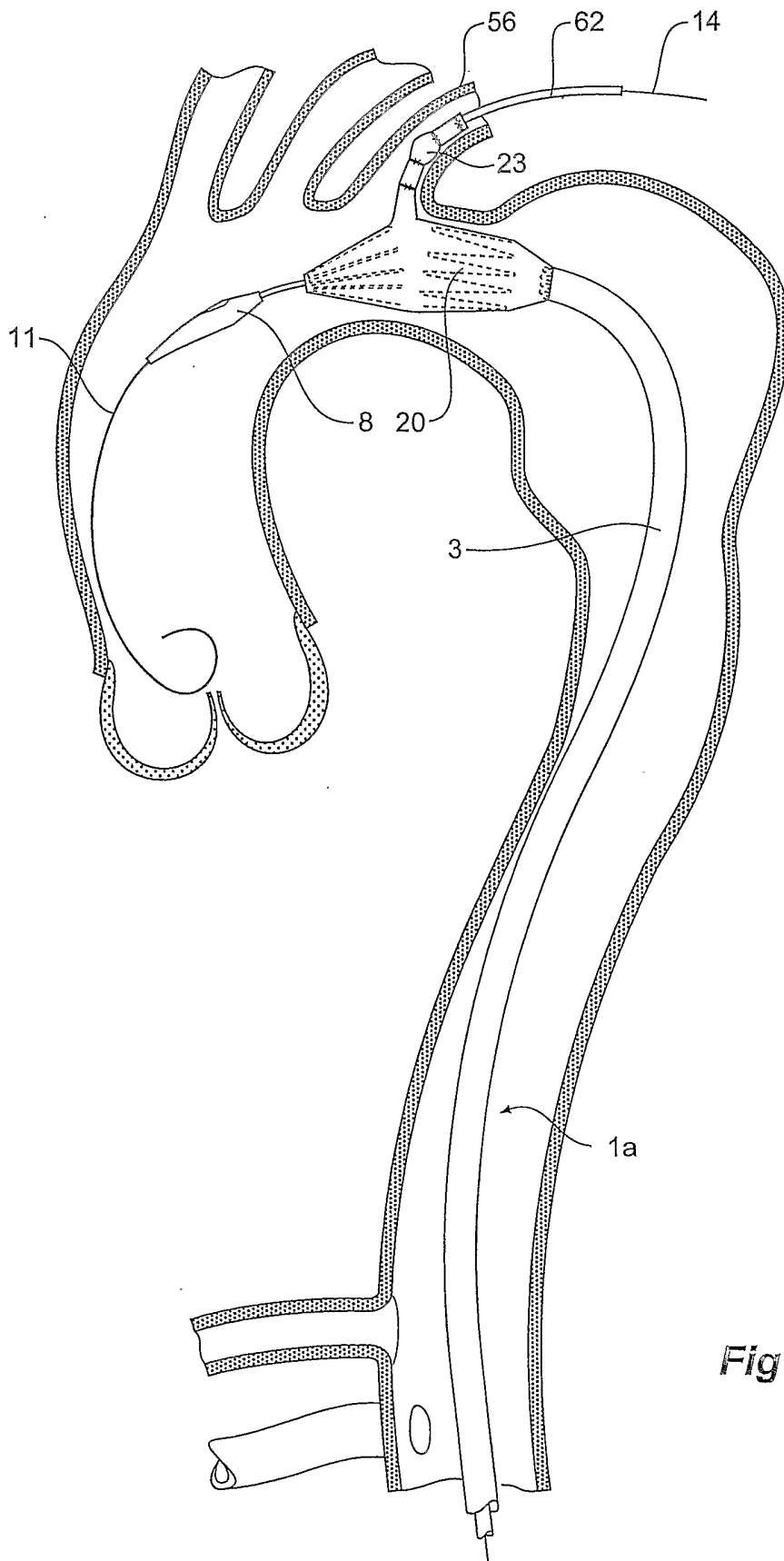

Fig 14

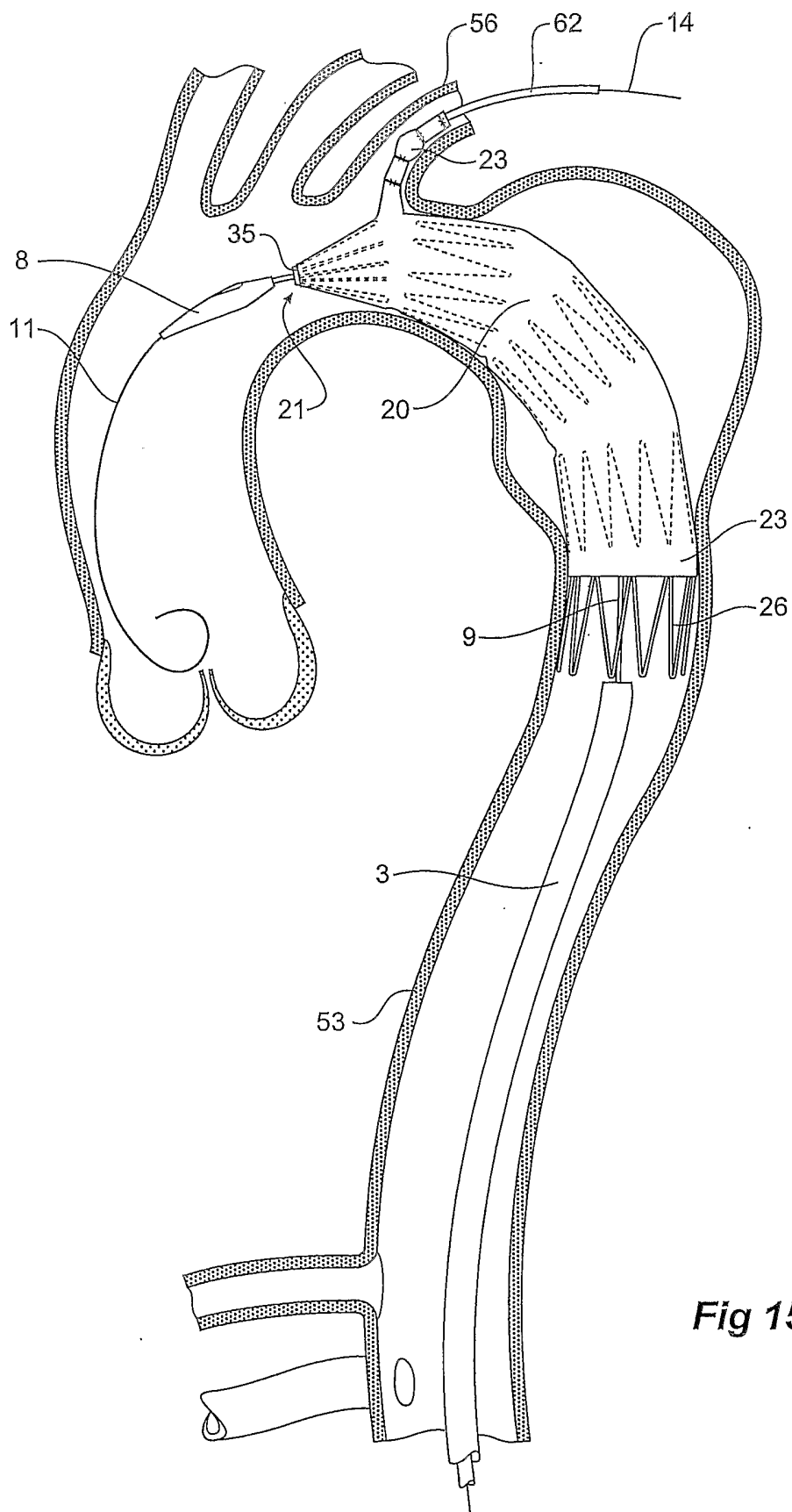

Fig 15

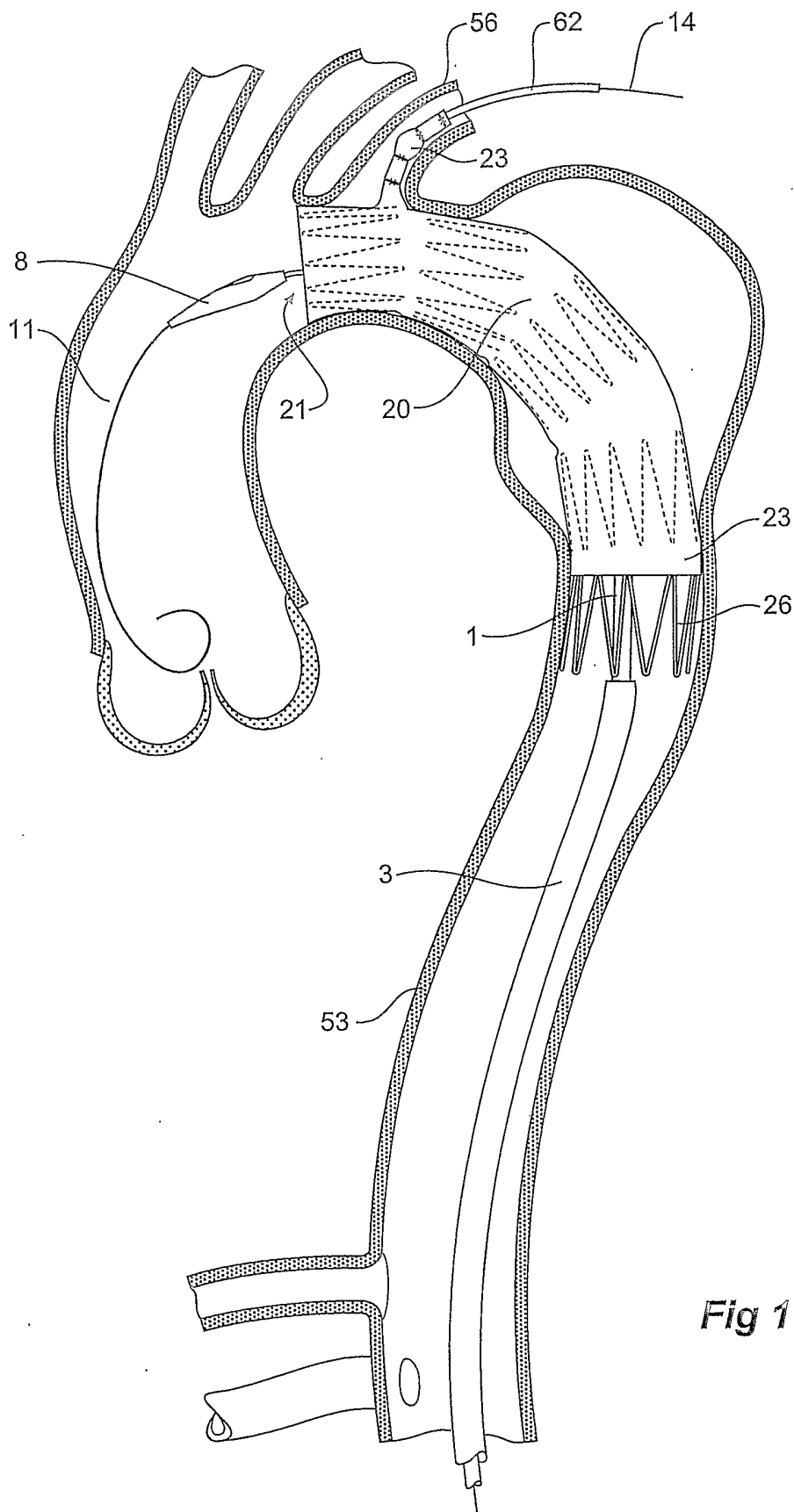

Fig 16

13/15

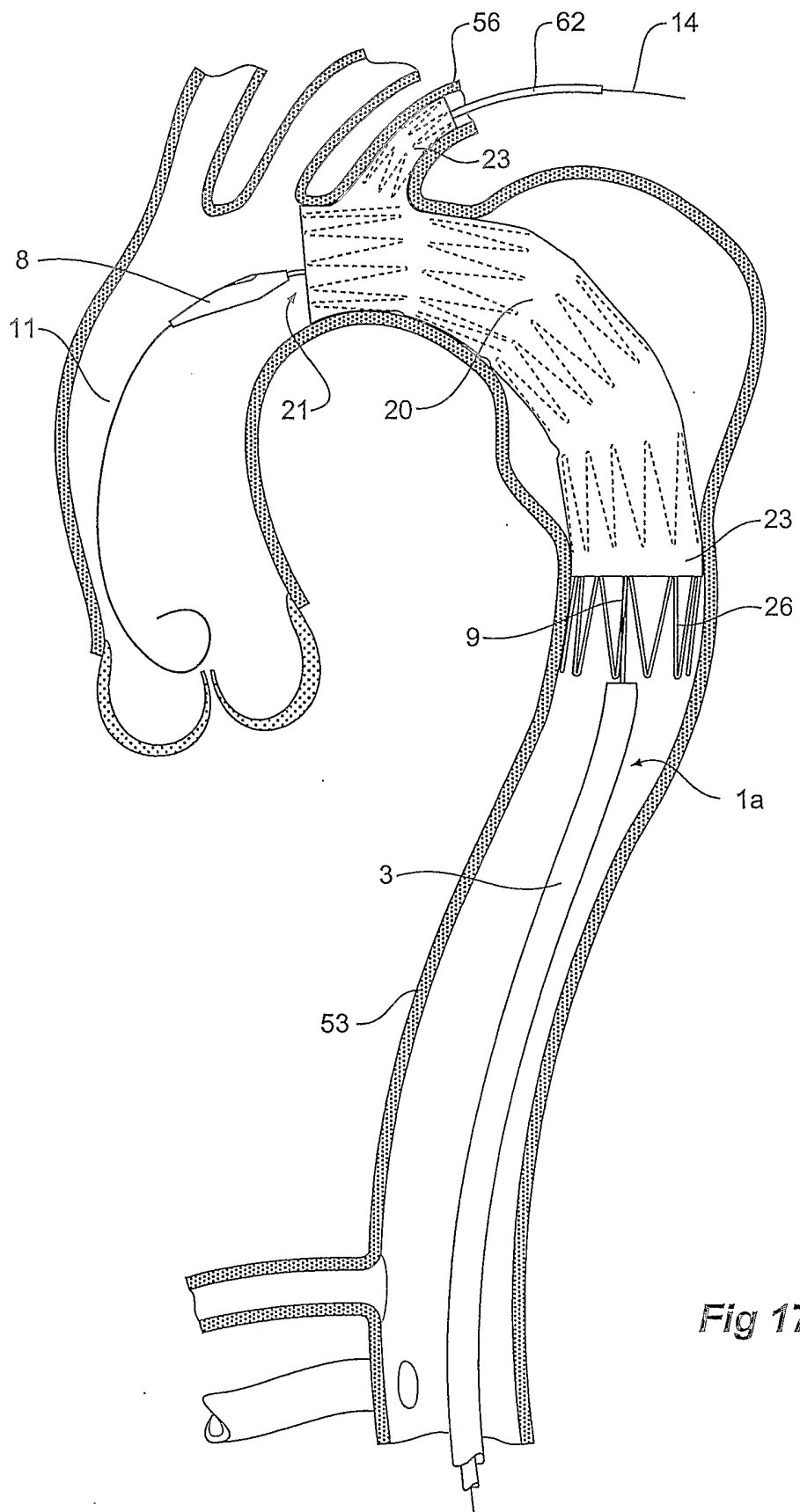

Fig 17

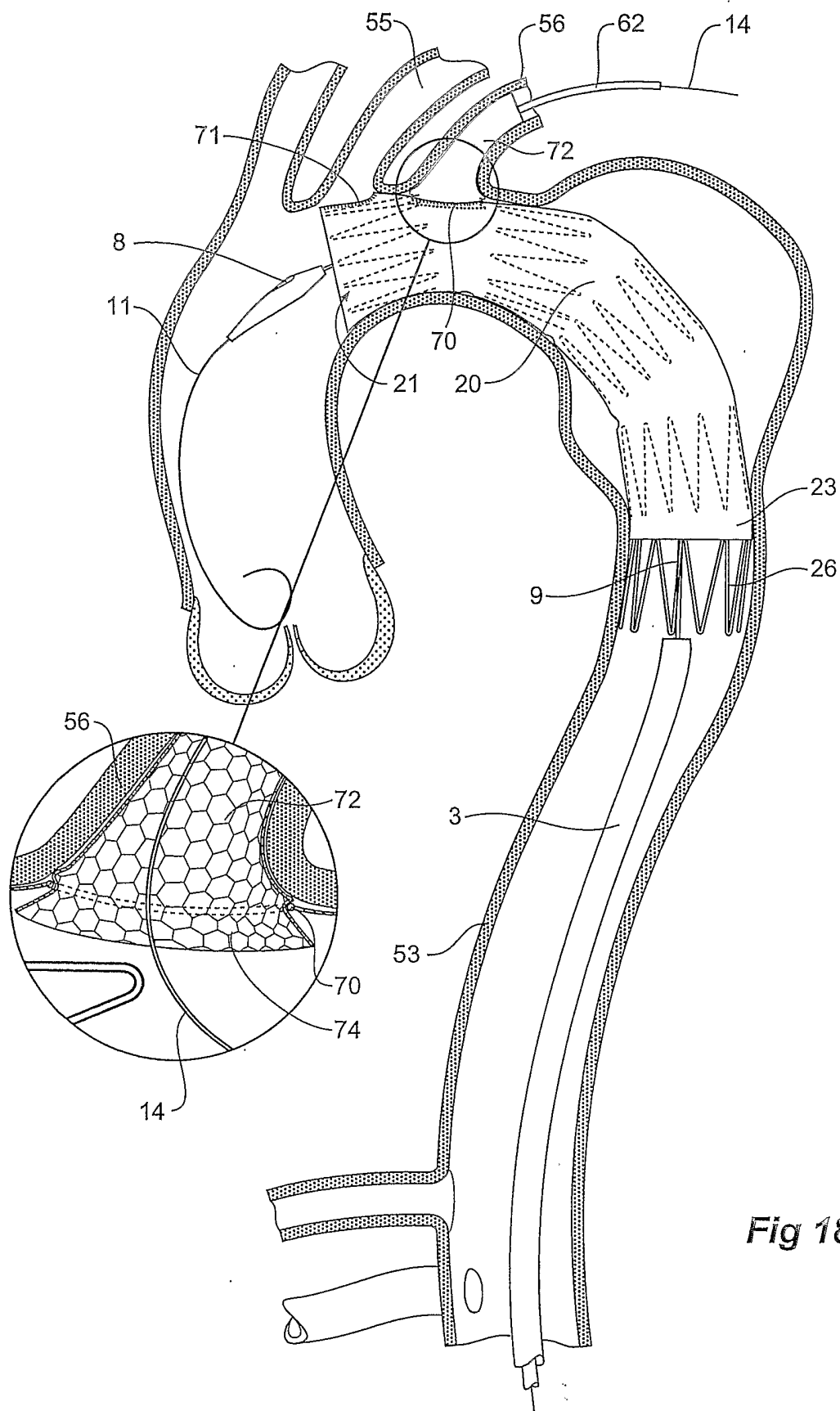

Fig 18

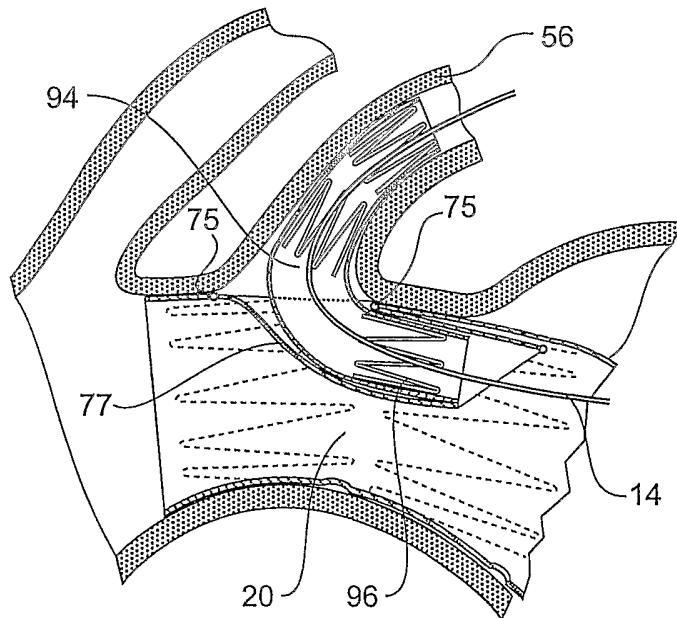

Fig 19

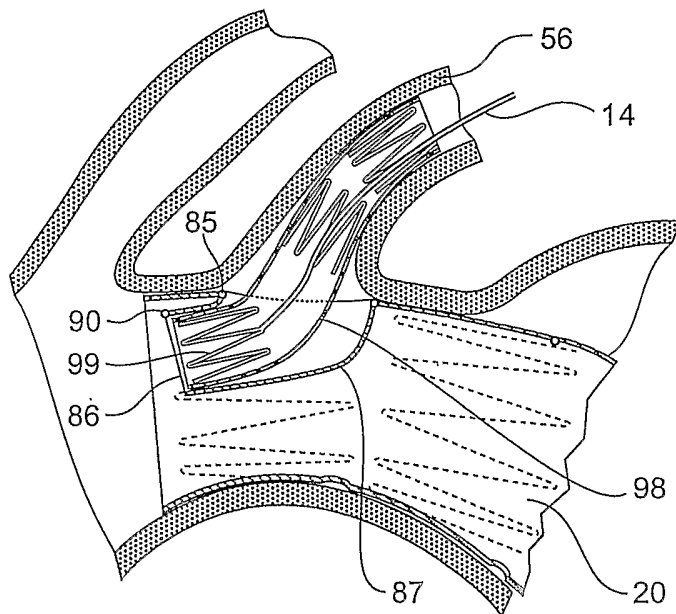

Fig 20

INTERNATIONAL SEARCH REPORT

International Application No
PCT/US2004/010445

A. CLASSIFICATION OF SUBJECT MATTER IPC 7 A61F2/06		
According to International Patent Classification (IPC) or to both national classification and IPC		
B. FIELDS SEARCHED Minimum documentation searched (classification system followed by classification symbols) IPC 7 A61F		
Documentation searched other than minimum documentation to the extent that such documents are included in the fields searched		
Electronic data base consulted during the international search (name of data base and, where practical, search terms used) EPO-Internal		
C. DOCUMENTS CONSIDERED TO BE RELEVANT		
Category °	Citation of document, with indication, where appropriate, of the relevant passages	Relevant to claim No.
X	EP 0 684 022 A (ENDOVASCULAR TECH INC) 29 November 1995 (1995-11-29)	1-3,9, 10, 13-15,17
Y	column 3, line 49 - column 35, line 31; figures 1,7,8	4-8,11, 12,16,18
Y	WO 99/36002 A (ELAM ERIC ; VARDI GIL M (US); LIN STUART (US); ADVANCED STENT TECHNOLO) 22 July 1999 (1999-07-22) figures 5-10	4-8,16, 18
Y	WO 01/67993 A (COOK WILLIAM A AUSTRALIA ; WILLIAM COOK EUROP APS (DK); COOK INC (US)) 20 September 2001 (2001-09-20) figures 15-21	11,12
<input type="checkbox"/> Further documents are listed in the continuation of box C. <input checked="" type="checkbox"/> Patent family members are listed in annex.		
° Special categories of cited documents :		
A document defining the general state of the art which is not considered to be of particular relevance *E* earlier document but published on or after the international filing date *L* document which may throw doubts on priority claim(s) or which is cited to establish the publication date of another citation or other special reason (as specified) *O* document referring to an oral disclosure, use, exhibition or other means *P* document published prior to the international filing date but later than the priority date claimed *T* later document published after the international filing date or priority date and not in conflict with the application but cited to understand the principle or theory underlying the invention *X* document of particular relevance; the claimed invention cannot be considered novel or cannot be considered to involve an inventive step when the document is taken alone *Y* document of particular relevance; the claimed invention cannot be considered to involve an inventive step when the document is combined with one or more other such documents, such combination being obvious to a person skilled in the art. *&* document member of the same patent family		
Date of the actual completion of the international search 29 September 2004		Date of mailing of the international search report 05/10/2004
Name and mailing address of the ISA European Patent Office, P.B. 5818 Patentlaan 2 NL - 2280 HV Rijswijk Tel. (+31-70) 340-2040, Tx. 31 651 epo nl, Fax: (+31-70) 340-3016		Authorized officer Skorovs, P

INTERNATIONAL SEARCH REPORT

International application No.
PCT/US2004/010445

Box II Observations where certain claims were found unsearchable (Continuation of item 2 of first sheet)

This International Search Report has not been established in respect of certain claims under Article 17(2)(a) for the following reasons:

1. Claims Nos.: 19, 20
because they relate to subject matter not required to be searched by this Authority, namely:
Rule 39.1(iv) PCT - Method for treatment of the human or animal body by surgery
2. Claims Nos.:
because they relate to parts of the International Application that do not comply with the prescribed requirements to such an extent that no meaningful International Search can be carried out, specifically:
3. Claims Nos.:
because they are dependent claims and are not drafted in accordance with the second and third sentences of Rule 6.4(a).

Box III Observations where unity of invention is lacking (Continuation of item 3 of first sheet)

This International Searching Authority found multiple inventions in this international application, as follows:

1. As all required additional search fees were timely paid by the applicant, this International Search Report covers all searchable claims.
2. As all searchable claims could be searched without effort justifying an additional fee, this Authority did not invite payment of any additional fee.
3. As only some of the required additional search fees were timely paid by the applicant, this International Search Report covers only those claims for which fees were paid, specifically claims Nos.:
4. No required additional search fees were timely paid by the applicant. Consequently, this International Search Report is restricted to the invention first mentioned in the claims; it is covered by claims Nos.:

Remark on Protest

- The additional search fees were accompanied by the applicant's protest.
- No protest accompanied the payment of additional search fees.

INTERNATIONAL SEARCH REPORT

Information on patent family members

International Application No

PCT/US2004/010445

Patent document cited in search report		Publication date	Patent family member(s)	Publication date
EP 0684022	A	29-11-1995	US 5628783 A	13-05-1997
			AT 259625 T	15-03-2004
			AU 1644499 A	29-04-1999
			AU 698892 B2	12-11-1998
			AU 6219396 A	31-10-1996
			AU 669448 B2	06-06-1996
			AU 7143894 A	23-11-1995
			CA 2130138 A1	13-11-1995
			CA 2257663 A1	13-11-1995
			CA 2302116 A1	13-11-1995
			DE 69532567 D1	25-03-2004
			EP 0684022 A2	29-11-1995
			JP 8038486 A	13-02-1996
			US 6682557 B1	27-01-2004
			US 6322587 B1	27-11-2001
			US 6355061 B1	12-03-2002
			US 6235050 B1	22-05-2001
			US 5769885 A	23-06-1998
			US 5824044 A	20-10-1998
			US 2004153143 A1	05-08-2004
US 6663666 B1	16-12-2003			
US 6039758 A	21-03-2000			
WO 9936002	A	22-07-1999	US 6210429 B1	03-04-2001
			AU 2228699 A	02-08-1999
			CA 2318314 A1	22-07-1999
			EP 1047356 A1	02-11-2000
			JP 2003532437 T	05-11-2003
			WO 9936002 A1	22-07-1999
			US 6325826 B1	04-12-2001
			US 2004015227 A1	22-01-2004
			US 2003028233 A1	06-02-2003
			US 2004138737 A1	15-07-2004
			US 2001003161 A1	07-06-2001
			US 2001016766 A1	23-08-2001
			US 2001037137 A1	01-11-2001
			AU 4896797 A	29-05-1998
			EP 0944366 A1	29-09-1999
			US 2002116047 A1	22-08-2002
			WO 9819628 A1	14-05-1998
			US 2003181923 A1	25-09-2003
			US 2002156516 A1	24-10-2002
			WO 0167993	A
CA 2400072 A1	20-09-2001			
EP 1263349 A2	11-12-2002			
JP 2003526452 T	09-09-2003			
WO 0167993 A2	20-09-2001			
US 2001037142 A1	01-11-2001			