

- (21) Application No 8003090
- (22) Date of filing 30 Jan 1980
- (30) Priority data
- (31) 54/100482
- (32) 19 Jul 1979
- (33) Japan (JP)
- (43) Application published 18 Feb 1981
- (51) INT CL<sup>3</sup>  
G11B 27/28 5/49  
21/16 // 5/52
- (52) Domestic classification  
G5R B264 B340 B342  
B343 B373 B37Y B38Y  
B402 B421 B475 B476  
B481 B511 B513 B544  
B638 B641 B643 B682  
B721 B783 B788 B789 JB  
KM
- (56) Documents cited  
GB 1516542  
GB 1497178  
GB 1246419  
GB 1227168  
GB 985859  
GB 960772  
GB 920779  
GB 812023
- (58) Field of search  
G5R
- (71) Applicants  
Sharp Kabushiki Kaisha,  
22—22 Nagaika-cho,  
Abeno-ku, Osaka 545,  
Japan
- (72) Inventor  
Masaya Hijikigawa
- (74) Agents  
R. G. C. Jenkins & Co.,  
Chancery House, 53/64  
Chancery Lane, London,  
WC2A 1QU

(54) **Magnetic reproduction apparatus**

(57) A program selection system is controlled by control signals magnetically recorded on a tape 2, Fig. 1, 32, Fig. 6, carrying the program(s), the control signals being detected by a magnetic head controlling the backing side of the tape. In a helical scan VTR, the control signals may be recorded in the video track zone of the tape by a full-width erase head 6 or may be the usual one signal recorded in a control track by a

head 9. The control signal detecting head is magnetoresistive and is located to contact the tape during fast forward and reverse winding. This head may be carried by a tape guide pin 5 or by a tape-tensioning pin 13. Such a tensioning pin 31, Fig. 6, which may be of Al, Zn or ABS resin, has a stainless steel tape-engaging film 35 thereon and covering the magnetoresistive detection head 34 served in an opening 33 in the pin 31, the head leader 37 being served by resin 38.

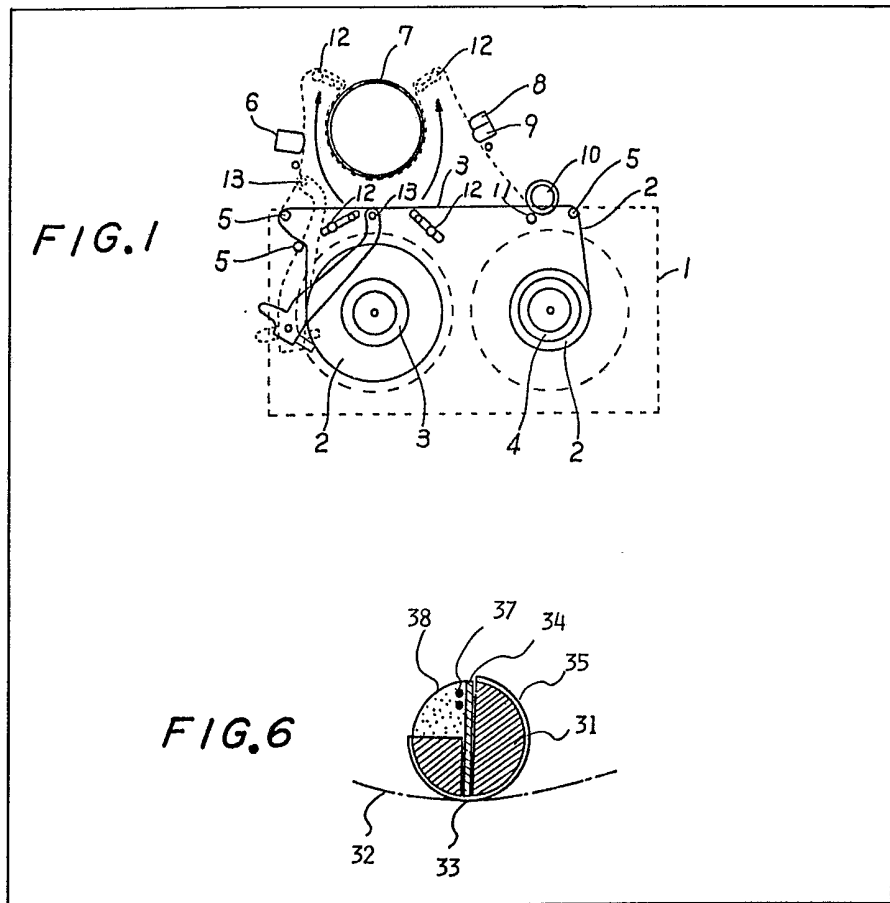

The drawings originally filed were informal and the print here reproduced is taken from a later filed formal copy.

GB 2 054 940 A

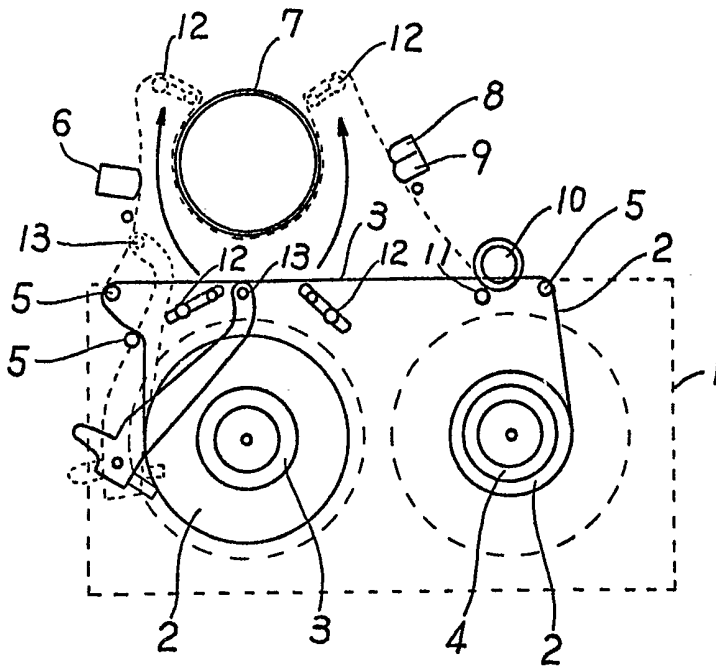

FIG. 1

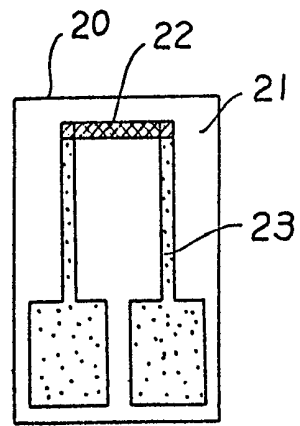

FIG. 2



FIG. 3 (A)

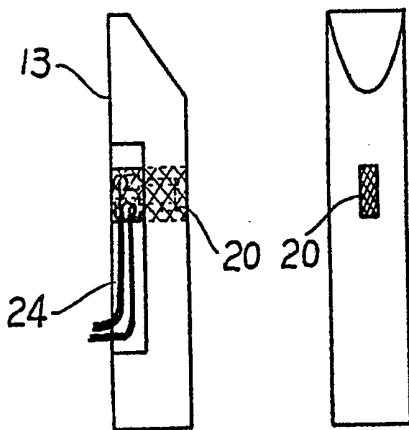

FIG. 3 (B) FIG. 3 (C)

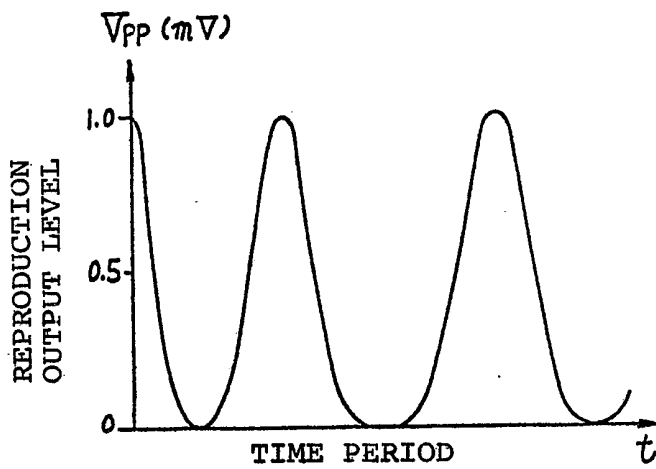

FIG. 4

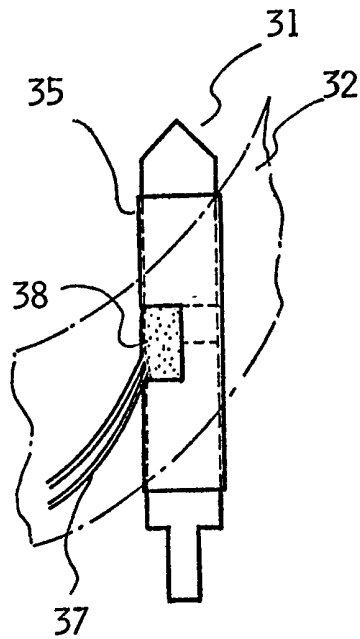

FIG. 5 (A)

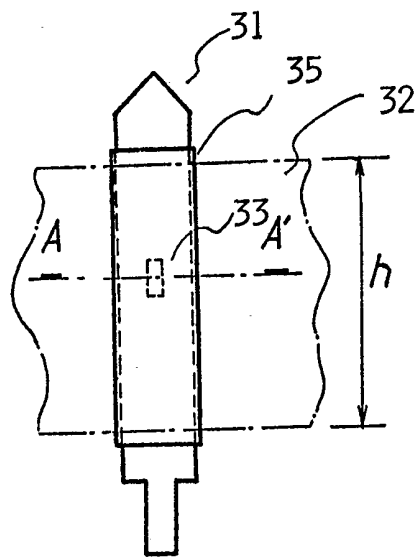

FIG. 5 (B)

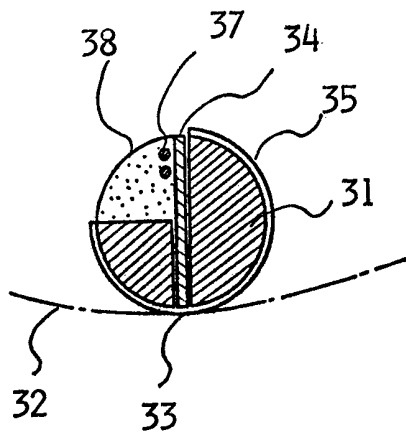

FIG. 6

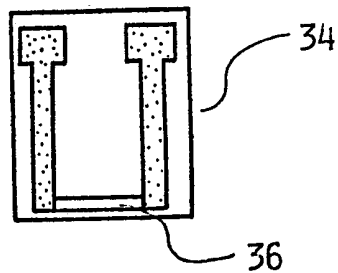

FIG. 7

## SPECIFICATION

**Magnetic reproduction apparatus**

## Background of the Invention

The present invention relates to a magnetic reproduce apparatus and particularly, but not exclusively, to an improved magnetic reproduction assembly useful for a magnetic reproduce apparatus with a magnetoresistive head.

The operating principle of magnetoresistive heads was disclosed in, for example, R. P. Hunt U.S. Pat. No. 3,493,694 issued Feb. 3, 1970, entitled "MAGNETORESISTIVE HEAD".

Since the magnetoresistive heads can provide output signals as high as about ten times those from the well-known electromagnetic effect type head, it is advisable that such magnetoresistive heads be applied to magnetic reproduce apparatuses to improve operation of the apparatuses.

## 20 Summary of the Invention

It is desirable to provide an improved program detection system, which may incorporate a magnetoresistive head, in an apparatus for reproducing magnetically-recorded programs.

25 In accordance with one aspect of the invention, there is provided apparatus for reproducing magnetically-recorded programs having means operable, in response to information recorded on a magnetic storage medium comprising a base member supporting a recording member, to detect a program recorded on the medium, said means comprising reproducing means arranged in use to contact said base element to detect and reproduce said information.

35 The reproducing means is preferably a magnetoresistive head.

In a preferred embodiment, the necessary reproduced signals are provided independently of travel speed of the magnetic storage medium, which is preferably a magnetic tape.

In an embodiment of the present invention, a magnetic record-reproduction device is provided for controlling a program selection system of a tape containing a recording member and a base element. The recording member records cue signals indicating positions of the tape to reproduce. The base element supports the recording member. A magnetoresistive head comes into contact with the base element for detecting and reproducing the cue signals recorded in the recording member.

## Brief Description of the Drawings

The present invention will become more fully understood from the detailed description given hereinbelow and the accompanying drawings which are given by way of illustration only, and thus are not limitative of the present invention and wherein:

FIG. 1 is a schematic representation of configuration of a magnetic reproduce apparatus according to the present invention;

FIG. 2 is a configuration of a magnetoresistive

head incorporated within the magnetic reproduce apparatus shown in FIG. 1;

65 FIGS. 3(A), 3(B), and 3(C) are a plan view, a side view, and a front view of a tension arm incorporated within the magnetic reproduce apparatus indicated in FIG. 1, respectively;

70 FIG. 4 is a graph representing reproduction output levels of the magnetic reproduce apparatus shown in FIG. 1 v. time in connection with cue signals;

75 FIGS. 5(A) and 5(B) are a side view and a front view of another example of the tension arm related to FIGS. 3(A) through 3(C);

FIG. 6 is a section taken in the plane indicated by line A—A' in FIG. 5(B); and

80 FIG. 7 is a configuration of another example of the magnetoresistive head incorporated within the tension arm shown in FIGS. 5(A) and 5(B), the magnetoresistive head being related to that shown in FIG. 2.

## Description of the Invention

FIG. 1 shows a cassette type video tape recorder (VTR) of the type which causes well-known helical scan. The VTR mainly comprises a cassette 1, a magnetic tape 2, a full-width erase head 6, a rotary head drum 7, an audio erase head 8, an audio control head 9, a loading arm 12, a tension arm 13, a magnetoresistive head 20, a substrate 21, a film element 22, a pair of conducting strips 23, and leads 24.

In particular, an appropriate amount of the magnetic tape 2 is wound around a supply reel 3 which is associated with a wind-up reel 4. Either the supply reel 3 or the wind-up reel 4 is selectively engaged with a driver source. Along the travel course of the magnetic tape 2, there are provided a guide pin 5, the full-width erase head 6, the rotary head drum 7, the audio erase head 8, the audio control head 9, a pinch roller 10, and a capstan roller 11.

Around the circumference of the rotary head drum 7, there are positioned two or four video heads. While they rotate at about 200 to 300 rps in the direction opposed to that of the travel of the magnetic tape 2, namely, in the direction in which the relative velocity between the magnetic tape 2 and the video heads increases, they contact or move away from the magnetic tape 2. During one rotation of the video heads, they scan the magnetic tape 2 by a field. The well-known helical scan mode is carried out wherein the magnetic tape 2 is in contact with a part of the circumference of the rotary head drum 7 with a certain angle with respect thereto.

The solid line in FIG. 1 indicates the path of the magnetic tape 2 separated from the rotary head drum 7 during forward operation and rewind operation. In such a case, the magnetic tape 2 extends between the pair of guide pins 5 each of which is disposed adjacent to the supply reel 3 and to the wind-up reel 4. It is unnecessary that the magnetic tape 2 be in contact with the rotary head drum 7.

The dotted line in FIG. 1 shows the path of the

magnetic tape 2 in contact with the rotary head drum 7 to cause reproduction of pictures. In such a case, the magnetic tape 2 is regulated by the full-width erase head 6, the rotary head drum 7, the audio erase head 8, and the audio control head 9. A pair of loading arms 12 is provided as a tape guide for changing the pathway for the magnetic tape 2 to the position where it comes into contact with the rotary head drum 7. The position of the pair of loading arms 12 is changed from the first position where the magnetic tape 2 is spaced from the rotary head drum 7 to the second position where the former is in contact with the latter as indicated by each of lines with an arrow head in FIG. 1.

The tension arm 13 positioned near the supply reel 3 is pivoted so that the tension arm 13 becomes contact with the back surface of the magnetic tape 2 which is in contact with the rotary head drum 7. The tension arm 13 stresses the magnetic tape 2 appropriately toward the drum 7. The wind-up reel 4 is engaged with the drive source for drive purposes, so that the magnetic tape 2 is subsequently traveled from the supply reel 3 to the wind-up reel 4. The rotary head drum 7 is operated to cause the reproduction of pictures recorded in the magnetic tape 2.

In addition to the reproduction of the pictures, the rotary head drum 7 functions to record video signals by the video heads provided therein. The full-width erase head 6 functions to completely erase the total signals recorded on the magnetic tape 2 and to record cue signals in video tracks of magnetic storage medium of the magnetic tape 2. The audio erase head 8 acts to erase only sound signals recorded in audio tracks of the magnetic tape 2.

The audio tracks are formed at the edge of the magnetic tape 2 along the travel direction of the magnetic tape 2. The audio control head 9 is provided for recording sound signals in audio tracks and recording control signals in control tracks of the magnetic tape 2. The control signals are recorded to obtain synchronization between video signals recorded in video tracks of the magnetic tape 2 and the sound signals recorded in the audio tracks of the same. The pinch roller 10 and the capstan roller 11 embrace in combination the magnetic tape 2 so that the magnetic tape 2 rotates round the rotary head drum 7 in a certain constant speed. Jitter of the pictures reproduced on a screen greatly depends upon the stability of travel speed of the magnetic tape 2. To secure stable travel speed of the magnetic tape 2, the pinch roller 10 and the capstan roller 11 are provided for embracing the magnetic tape 2 in pressure and, in addition, the tension arm 13 is employed to stress the magnetic tape 2 constantly toward the rotary head drum 7.

At the top of the tension arm 13, there is coupled a magnetoresistive head comprising a film element, preferably, formed of a thin, narrow strip of ferromagnetic metallic material of low anisotropy, such as Permalloy. The magnetoresistive head is provided for detecting

cue signals recorded in the magnetic tape 2. The cue signals are recorded to indicate positions of programs recorded in the magnetic tape 2, while the magnetic tape 2 is traveled. The record of the cue signals permits the well-known program selection system. The cue signals are detected during the rewind operations and the forward operations of the magnetic tape 2. As the magnetoresistive head is disposed on the top of the tension arm 13, the magnetoresistive head comes in contact with the back surface of the magnetic tape 2. The back surface of the magnetic tape 2 is opposite to the front surface of it which is in contact with the rotary head drum 7.

According to the provision of the magnetoresistive head disposed on the top of the tension arm 13, the change of travel of the magnetic tape 2 is not prevented by the magnetoresistive head. This means that the space for required magnetic heads can be as compact as possible. On the front surface of the magnetic tape 2, there is formed a layer of a magnetic material as a magnetic storage medium. Therefore, on the back surface of the magnetic tape 2, there is formed a base layer for supporting the magnetic layer.

When it is directed during the rewind operations or the forward operations of the magnetic tape 2 that the cue signals should be detected, the top of the tension arm 13 is controlled by a drive means so that it comes in contact with the back surface of the magnetic tape 2 extended between the pair of the guide pins 5 each of which is adjacent to the supply reel 3 and to the wind-up reel 4. The magnetoresistive head is supplied with an appropriate amount of current for driving purposes in order to detect and reproduce the cue signals. The top of the tension arm 13 may be disposed to be continuously in contact with the back surface of the magnetic tape 2 during its rewind operations or its forward operations. The cue signals are erased by the full-width erase head 6.

The principle of the present invention will be now explained as follows: If the reproduction of data record on the magnetic tape 2 were obtained using the back surface of it comprising no magnetic storage medium, spacing loss would be inevitably increased at least by the thickness of the base layer for supporting the magnetic storage medium disposed as the front surface of the magnetic tape 2. This means that reproduction output signals are decreased; The spacing loss is well-known as

$$-54.6 \frac{d}{\lambda} \text{ (dB)}$$

(d: the spacing, λ: recorded frequency). This equation indicates that the spacing loss is minimized as the record frequency becomes longer; It may be possible that an adequately long recorded frequency be reproduced from the back surface of the magnetic tape 2; The minimum

record frequency which can be obtained from the back surface of the magnetic tape 2 depends on a strength of a magnetic field for record, the thickness of the magnetic storage medium, the thickness of the base layer, the gap between the magnetic heads, the reproduction efficiency, and the like.

In addition, in the conventional head utilizing an electromagnetic effect, the minimum recorded frequency which can be reproduced from the back surface was relied upon the relative velocity between the magnetic heads and the magnetic storage medium; Thus it was impossible in practice to obtain the record signals from the back surface because it was required in the conventional head that the minimum recorded frequency became a great amount wherein the magnetic tape 2 and the magnetic heads were driven by a large amount of speed, the contents of information to be recorded was decreased, and the drive system was increased in power; On the contrary, in connection with the magnetoresistive head of the present invention, the minimum recorded frequency available becomes independent on the relative velocity between the magnetic heads and the magnetic storage medium; The magnetoresistive head is superior about ten times to the conventional head in obtaining recorded signals; And the magnetoresistive head can be formed according to steps that a magnetic film, a conductive film, and an insulating film are formed on a substrate by vacuum evaporation methods or plating methods and then are patterned by chemical etching techniques. The magnitude of the magnetoresistive head can be compact considerably as compared with the conventional head.

According to the above-mentioned principle, the magnetoresistive head is incorporated within the tension arm 13. FIG. 2 shows an example of a preferred embodiment of the magnetoresistive head 20. FIGS. 3(A), 3(B), and 3(C) are respectively a plan view, a side view, and a front view of the top of the tension arm 13 containing the magnetoresistive head 20 shown in FIG. 2.

With reference to FIG. 2, the magnetoresistive head 20 comprises a substrate 21, a magnetic film 22, and a pair of conductors 23. The substrate 21 is made of glass and the like. The magnetic film 22 is preferably formed of a thin-narrow strip of ferromagnetic metallic material of low anisotropy such as Permalloy, having a width of the order about 1 mm, and a thickness of the order of about 300 angstroms.

The magnetoresistive head 20 detects the magnetic fields associated with the magnetization within the magnetic storage medium. The magnetic film 22 is of low anisotropy electrically-conductive magnetic material secured in magnetically bridging relation adjacent the magnetic storage medium. The magnetic film 22 has a selected magnetization state responsive to the magnetic fields within the magnetic storage medium which rotate the magnetization in the

magnetic film 22 and vary accordingly the resistivity thereof. The magnetic film 22 is formed on the substrate 21 according to the vacuum evaporation techniques or the plating methods. The pair of the conductors 23 are also formed on the substrate 21 such that they are connected to each of the ends of the magnetic film 22 for picking up electromotive force caused in the magnetic film 22.

In FIGS. 3(A) to 3(C), the top of the tension arm 13 is composed of a nonmagnetic material in a rod shape having diameter of about 5 mm. The magnetoresistive head 20 is buried with the tension arm 13 such that the magnetoresistive head 20 is secured in separation from a contact surface to the magnetic tape 2 in the order of about 80  $\mu\text{m}$ . A pair of parallel dotted lines shown in FIG. 3(A) indicate the provision of the magnetoresistive head 20. As viewed from FIG. 3(B), there are provided a pair of lead lines 24 connected to each of the pair of the conductors 23. A dotted line perpendicular to the pair of the parallel dotted lines shown in FIG. 3(A) shows the arrangement of the pair of the lead line 24. The pair of the lead like 24 is coupled to a detection circuit at the exterior of the tension arm 13. A latticed symbol shown in FIG. 3(B) indicates a buried portion of the magnetoresistive head 20 within the tension arm 13.

FIG. 4 shows a graph showing reproduction characteristics of the cue signals obtained by the magnetoresistive head shown in FIG. 2. The cue signals are recorded within the video tracks by the full-width erase head 6. The cue signals are characterized in that the recorded frequency is about 1 mm and the width of recorded tracks is about 10 mm. The cue signals are reproduced by the magnetoresistive head during the rewind operations or the forward operations of the magnetic tape 2. The width of the magnetic film 22 of the magnetoresistive head 20 available in detecting the cue signals is in the order of about 1 mm.

The data in FIG. 4 are plotted with reproduction output levels  $V_{pp}$  (mv) as ordinate the time period as abscissa. Provided that the base layer of the magnetic tape 2 is about 16  $\mu\text{m}$  in thickness, the spacing between the magnetoresistive head 22 and the magnetic storage medium of the magnetic tape 2 is about 0.1 mm. The data of FIG. 4 are obtained under the condition where an appropriate amount of detection current in the order of about 5 mA is applied to the magnetoresistive head and, in addition, any bias current is not applied thereto.

As viewed from FIG. 4, the reproduction output levels  $V_{pp}$  are obtained in the order of about 1 mV. The S/N ratio is well enough.

In another example of a preferred form of the present invention, the magnetoresistive head 20 may be formed on any of the guide pin 5 or any other element adjacent the magnetic tape 2 except the tension arm 13.

The range of the recorded frequency of the cue signals which can be detected by the

magnetoresistive head according to the principle of the present invention is in the order of about 200 or 300  $\mu\text{m}$  to about 2.0 mm under the condition that the width of the magnetic film 22 of the magnetoresistive head 20 available in detecting the cue signals is in the order of about 100  $\mu\text{m}$  and that the spacing between the magnetic storage medium of the magnetic tape 2 and the magnetic film 22 of magnetoresistive head 20 is in the order of about 100  $\mu\text{m}$ . If the spacing is smaller, the recorded frequency of the cue signals to be detected by the magnetoresistive head is decreased to several microns.

In the above-mentioned preferred embodiment of the present invention, the cue signals are recorded in the video tracks in the magnetic storage medium of the magnetic tape 2 by the full-width erase head 6 as disclosed in Japanese published unexamined patent application No. 81211/1978 laid open on July 18, 1978. Instead, the cue signals can be recorded in the control tracks in the magnetic storage medium of the magnetic tape 2 by the audio control head 9 as disclosed in Japanese published examined patent application No. 14205/1978 published on May 16, 1978. In short, as far as the cue signals are recorded in any of tracks in the magnetic tape 2 having a width of the order of about 10  $\mu\text{m}$ , the cue signals can be reproduced by the magnetoresistive head of the present invention regardless of the position of the tracks within the magnetic tape 2. The magnetoresistive head can be adopted in its stripe length and its stalled position to permit the cue signals to be detected.

FIGS. 5(A) and 5(B) show respectively a side view and a front view of another preferred form of the tension arm containing the magnetoresistive head according to the present invention related to FIGS. 3(B) and 3(C). In FIGS. 5(A) and 5(B), there are provided a tension arm 31, a magnetic tape 32, an opening 33, a non-magnetic metallic film 35, a pair of leads 37, and a resin material 38.

The diameter of the tension arm 31 is in the order of about 5 to 7 mm. The magnetic tape 32 is traveled in a location indicated by a numeral h in FIG. 5(B). The opening 33 is formed to bury the magnetoresistive head. The magnetoresistive head is positioned to confront the tracks in the magnetic tape 32 in which the cue signals are recorded. The tension arm 31 is composed of Zn, Al, or any metallic material which is made as die casting. To secure abrasion-resistance of the tension arm 31 against the magnetic tape 32, the non-magnetic metallic film 35 is wound around a surface of the tension arm 31. The magnetic tape 32 is in contact with the tension arm 31 on this surface. The non-magnetic metallic film 35 is made of SUS 303, SUS 304, SUS 316, or any other stainless steel material. The non-magnetic metallic film 35 is fixed to the body of the tension arm 31 by means of spot welding. Instead of metallic material of Zn and the like of the tension arm 31, any synthetic resin such as a ABS resin may be adopted for the tension arm 31.

The pair of the leads 37 shown in FIG. 5(A) is

related to the pair of the lead lines 24 indicated in FIG. 3(B). The resin material 38 is provided for supporting the pair of the leads 37.

FIG. 6 is a section taken in the plane indicated by line A—A' indicated in FIG. 5(B). An element of a magnetoresistive head 34 is enburied within the opening 33 of the tension arm 31.

FIG. 7 shows the magnetoresistive head 34 in detail related to FIG. 2. The magnetoresistive head 34 comprises a magnetic film 36 shown in FIG. 7 associated with the magnetic film 22 indicated in FIG. 2.

The magnetoresistive head 34 is in contact with the base layer of the magnetic tape 32, the base layer comprising no magnetic storage medium. The spacing between the magnetic film 36 and the magnetic storage medium of the magnetic tape 32 formed on the base layer is calculated as at least the sum of the thickness of the base layer of the magnetic tape 32 and the thickness of the non-magnetic metallic film 35. Preferably, the thickness of the base layer is in the order of about 20  $\mu\text{m}$  and that of the non-magnetic metallic film 35 is in the order of about 50  $\mu\text{m}$ . The spacing is obtained as about 70  $\mu\text{m}$ .

Conventionally, the base layer of the magnetic tape 2 or 32 is composed of a thin film made of polyethylene terephthalate (PET) and the like. The base layer of such the thin film provides less abrasion to the magnetic film of the magnetoresistive head than the magnetic storage medium of the magnetic tape. Since the magnetoresistive head does not come in contact with the magnetic storage medium, the magnetic storage medium is protected from being damaged by the magnetoresistive head. If the magnetic storage medium is damaged, reproduction output signals are dropped out.

As described above, in accordance with the present invention, the cue signals recorded in the magnetic tape can be detected and reproduced with efficiency. The cue signals are characterized by having relative long recorded frequencies. The following features are obtained according to the present invention:

(1) The cue signals are detected regardless of the travel speed of the magnetic tape.

(2) The operations of a total device for driving the magnetic tape are not prevented by a system for detecting and reproducing the cue signals.

(3) Any additional independent operating mechanism is not required to be added to the total device for driving the magnetic tape.

(4) The magnetic storage medium formed in the magnetic tape is not damaged by the system for sensing the cue signals recorded in the magnetic storage medium.

(5) The magnetic film of the magnetoresistive head is protected from abrasion by means of the magnetic tape.

(6) The magnetic film can be readily constructed as a multichannel head element where it senses the cue signals recorded in two or more tracks of the magnetic storage medium of the magnetic tape.

As far as the base layer of an extensible magnetic tape is not too thick wherein the cue signals can be sensed, such that the extensible magnetic tape can be adopted as a storage medium for the present invention in place of the above-stated magnetic tape.

The invention being thus described, it will be obvious that the same may be varied in many ways. Such variations are not to be regarded as a departure from the spirit and scope of the invention, and all such modifications are intended to be included within the scope of the following claims.

#### CLAIMS

1. A magnetic record-reproduction device for controlling a program selection system of a tape means comprising a recording member and a base element, the recording member recording information indicating positions of programs recorded therein and the base element supporting the recording member, the magnetic record-reproduction device comprising:

means in contact with the base element for detecting and reproducing the information recorded in the recording member to cause the program selection system.

2. The device as set forth in claim 1, wherein the detecting and reproducing means comprises a magnetoresistive film element.

3. The device as set forth in claim 2, wherein the magnetoresistive film element is composed of ferromagnetic material of low anisotropy.

4. The device as set forth in claim 1, wherein the detecting and reproduction means is provided as a part of a tape guide member for regulating the travel of the tape means.

5. The device as set forth in claim 1, wherein the detecting and reproducing means is disposed on an arm for stressing the tape means toward a head for reproducing picture signals recorded in the recording member.

6. The device as set forth in claim 1, wherein the information recorded in the recording member

useful for the program selection system has a frequency in the range of several microns to about 2.0 mm.

7. The device as set forth in claim 1, wherein the information recorded in the recording member useful for the program selection system is recorded in video tracks of the recording member wherein video signals are recorded.

8. The device as set forth in claim 1, wherein the information recorded in the recording member useful for the program selection system is recorded in control tracks of the recording member wherein control signals are recorded to determine the synchronization between video signals and sound signals both recorded in the recording member.

9. The device as set forth in claim 4, wherein the tape guide is composed of Zn, Al or any metallic material which is made as die casting, or of a synthetic resin.

10. The device as set forth in claim 1, wherein the detecting and reproducing means is provided as a part of a member covered by non-magnetic material.

11. The device as set forth in claim 10, wherein the non-magnetic material is composed of a stainless steel material.

12. The device as set forth in claim 1, wherein the detecting and reproducing means is buried within an element.

13. Apparatus for reproducing magnetically-recorded programs having means operable, in response to information recorded on a magnetic storage medium comprising a base member supporting a recording member, to detect a program recorded on the medium, said means comprising reproducing means arranged in use to contact said base element to detect and reproduce said information.

14. Reproduction apparatus substantially as herein described with reference to Figures 1 to 4, optionally as modified with reference to Figures 5 and 6 and/or Figure 7, of the accompanying drawings.