

(12) STANDARD PATENT APPLICATION (11) Application No. AU 2018256547 A1
(19) AUSTRALIAN PATENT OFFICE

- (54) Title
Video prediction encoding device, video prediction encoding method, video prediction encoding program, video prediction decoding device, video prediction decoding method, and video prediction decoding program
- (51) International Patent Classification(s)
H04N 19/50 (2014.01)
- (21) Application No: **2018256547** (22) Date of Filing: **2018.10.31**
- (43) Publication Date: **2018.11.22**
(43) Publication Journal Date: **2018.11.22**
- (62) Divisional of:
2016210706
- (71) Applicant(s)
NTT DOCOMO, INC.
- (72) Inventor(s)
FUJIBAYASHI, Akira;BOON, Choong Seng;TAN, Thiew Keng
- (74) Agent / Attorney
Spruson & Ferguson, GPO Box 3898, Sydney, NSW, 2001, AU

VIDEO PREDICTION ENCODING DEVICE, VIDEO PREDICTION ENCODING METHOD, VIDEO PREDICTION ENCODING PROGRAM, VIDEO PREDICTION DECODING DEVICE, VIDEO PREDICTION DECODING METHOD, AND VIDEO PREDICTION DECODING PROGRAM

ABSTRACT

Disclosed is a video predictive decoding method executed by a video predictive decoding device, and a video predictive decoding device. In one aspect, the video predictive decoding method executed by the video predictive decoding device, comprises: an input step of inputting encoded data comprising compressed picture data which includes information on a target picture frame size, a maximum number of storable reconstructed pictures, and a maximum frame size specified as an encoding constraint, wherein a plurality of pictures forming a video sequence are encoded by either intra-frame prediction or inter-frame prediction; a decoding step of decoding the compressed picture data, and the compressed picture data indicating the information on the target picture frame size, the maximum number of storable reconstructed pictures and the maximum frame size, to reconstruct the pictures, and the information on the target picture frame size, the maximum number of storable reconstructed pictures and the maximum frame size; a picture storage step of storing in picture storage means one or more of the reconstructed pictures as reference pictures to be used for decoding a subsequent picture; and a memory control step of controlling the picture storage means, wherein a frame size of the input pictures has been compared with $1/2$ of the maximum frame size of the pictures, and the maximum number of reconstructed pictures storable in a frame memory has been determined as 2 times of a maximum number of initially storable reconstructed pictures when the frame size of the input pictures is not more than $1/2$ of the maximum frame size of the pictures.

VIDEO PREDICTION ENCODING DEVICE, VIDEO PREDICTION ENCODING METHOD, VIDEO PREDICTION ENCODING PROGRAM, VIDEO PREDICTION DECODING DEVICE, VIDEO PREDICTION DECODING METHOD, AND VIDEO PREDICTION DECODING PROGRAM

[0001A] The present application is a divisional of Australian Patent Application No. 2016210706, filed 4 August 2016, which itself is a divisional of Australian Patent Application No. 2013284789, filed 24 April 2013. The content of Australian Patent Application No. 2016210706 and Australian Patent Application No. 2013284789 is incorporated herein by reference in their entirety.

Technical Field

[0001] The present invention relates to video predictive encoding and decoding devices, methods, and programs and, more particularly, to devices, methods, and programs to manage the maximum number of reconstructed pictures storable in a decoded picture buffer.

Background Art

[0002] The video compression technologies are used for efficiently transmitting and storing video data. MPEG1-4 and H.261 to H.264 are widely used video data compression standards.

[0003] In these video compression standards, a picture to be encoded is divided into a plurality of blocks, which are encoded and then decoded. In order to increase the coding efficiency, below described prediction coding is used. In intra-frame prediction, a predictive signal is generated using a signal of a reconstructed neighboring picture (a signal restored from a previously compressed picture data) which is present in the frame including the target block. By subtracting the predictive signal from a signal of the target block, a difference between them is obtained and encoded. In inter-frame prediction, a reconstructed picture signal, which is

present in a frame different from the frame including a target block, is searched for a displacement of the signal. A predictive signal is generated to compensate the displacement. By subtracting the predictive signal from the signal of the target block, a difference between them is obtained and encoded. The reconstructed picture which is the subject of the motion search and compensation is referred to as a reference picture.

[0004] In bidirectional inter-frame prediction, not only is a past picture referenced, but also a future picture is referenced which is ordered for display after the target picture (the future pictures need to be encoded and reconstructed prior to encoding of the target picture). Then, predictive signals acquired from the past picture and the future picture are averaged. This prediction method is effective to predict an object not present in the past but thrown in a future frame and to reduce noise included in the two predictive signals.

[0005] Furthermore, in the inter-frame prediction defined in H.264, a plurality of reference pictures which have been encoded and then reconstructed are subjected to motion search, and the predictive signal with the smallest error is selected as an optimum predictive signal for the target block. A difference is calculated between the pixel signal of the target block and the optimum predictive signal and then subjected to a discrete cosine transform, quantization, and entropy encoding. At the same time, information is encoded which identifies the selected reference picture and the region in the selected reference picture from which the optimum predictive signal for the target block is acquired (referred to as a "reference index" and a "motion vector," respectively).

[0006] In H.264, a plurality of reconstructed pictures may be referenced. These reconstructed pictures are stored, as reference pictures to be used in prediction, in a decoded picture buffer (DPB), which is a picture buffer memory. The size of the decoded picture buffer (DPB) is defined by a profile and a level, and defined as a bit count, instead of the number of reference pictures. Even with the same profile and level, the number of the storable reference pictures varies according to the frame size of pictures. For example, in the case where the

profile is main (Main) and the level is 3.2, the maximum size of the picture buffer (MaxDPBSize: Maximum Decoded Picture Buffer Size) for storage of reference pictures used for prediction is defined as 7680.0×1024 [bytes]. Therefore, the number of reconstructed pictures storable in the decoded picture buffer (DPB) is 5 if the pictures are of 1280×720 and 4:2:0, and the maximum number of reconstructed pictures storable in the decoded picture buffer (DPB) is 4 if the pictures are of 1280×1024 and 4:2:0. Figs. 1(a), 1(b) and 1(c) show pictures arranged in the decoded picture buffer in which the frame sizes of the pictures determine the maximum number of storable reconstructed pictures, which is 4 (Fig. 1(a)), 5 (Fig. 1(b)), or 6 (Fig. 1(c)). Memory pointers are provided adaptively to the frame size of the reconstructed pictures in the picture buffer memory prepared in advance, whereby an adaptive memory arrangement is achieved in the picture buffer memory.

[0007] Non Patent Literature 1: "H.264: Advanced video coding for generic audiovisual services," Joint Video Team of ITU-T VCEG and ISO/IEC MPEG, ITU-T Rec. H.264 and ISO/IEC14496-10 (MPEG4-Part 10), November 2007.

[0008] Since the decoding device which complies with the foregoing requirements of H.264 needs to be able to decode pictures of all frame sizes defined by the profiles and levels which fall within the range supported by the decoding device, it is not possible to arrange memories in the picture buffer memory and store reconstructed pictures in these memories in a fixed manner. For this reason, it is necessary to vary, according to the frame size of pictures to be decoded, the memory pointers pointing the positions of memories for storing the reconstructed pictures, resulting in making the memory control and implementation complicated.

[0009] A makeshift solution to this problem is adopting a technique in which the maximum number of reconstructed pictures storable in the picture buffer memory (`max_dec_pic_buffering`) is fixed, regardless of the frame sizes of decoded pictures. Under this solution, since the memory arrangement of the decoded picture buffer (DPB) is fixedly determined by the maximum frame size as shown in Fig. 2(a), the memory pointers can also be

fixed. Namely, the memory control becomes easier compared to the arrangement in which the memory pointers need to be variably controlled. However, when the frame size of decoded pictures is smaller than the maximum frame size or when the vertical width of pictures is half of that of the frame pictures as in the case of interlaced field pictures, implementation of the above solution could generate unused memory regions as shown in Fig. 2(b) and prevent the memory from being effectively used. Furthermore, the solution could deprive a room for improving the coding efficiency which could be realized by storing more reconstructed pictures to increase the number of reference pictures.

Summary

[0009A] It is the object of the present invention to substantially overcome or at least ameliorate one or more of the above disadvantages.

[0010] Aspects of the present disclosure provide encoding and decoding methods, devices, and programs in which the maximum number of reconstructed pictures storable in the picture buffer memory is determined, according to the frame size of reconstructed pictures, thereby enabling the efficient use of the picture buffer memory and further improvement of the coding efficiency.

[0010A] An aspect of the present invention provides a video predictive decoding method executed by a video predictive decoding device, comprising: an input step of inputting encoded data comprising compressed picture data which includes information on a target picture frame size, a maximum number of storable reconstructed pictures, and a maximum frame size specified as an encoding constraint, wherein a plurality of pictures forming a video sequence are encoded by either intra-frame prediction or inter-frame prediction; a decoding step of decoding the compressed picture data, and the compressed picture data indicating the information on the target picture frame size, the maximum number of storable reconstructed pictures and the maximum frame size, to reconstruct the pictures, and the information on the target picture frame

size, the maximum number of storable reconstructed pictures and the maximum frame size; a picture storage step of storing in picture storage means one or more of the reconstructed pictures as reference pictures to be used for decoding a subsequent picture; and a memory control step of controlling the picture storage means, wherein a frame size of the input pictures has been compared with $1/2$ of the maximum frame size of the pictures, and the maximum number of reconstructed pictures storable in a frame memory has been determined as 2 times of a maximum number of initially storable reconstructed pictures when the frame size of the input pictures is not more than $1/2$ of the maximum frame size of the pictures.

[0010B] An aspect of the present invention provides a video predictive decoding device comprising: input means that inputs encoded data comprising compressed picture data which includes information on a target picture frame size, a maximum number of storable reconstructed pictures, and a maximum frame size specified as an encoding constraint, wherein a plurality of pictures forming a video sequence are encoded by either intra-frame prediction or inter-frame prediction; decoding means that decodes the compressed picture data, and the compressed picture data indicating the information on the target picture frame size, the maximum number of storable reconstructed pictures and the maximum frame size, to reconstruct the pictures, and the information on the target picture frame size, the maximum number of storable reconstructed pictures and the maximum frame size; picture storage means that stores one or more of the reconstructed pictures as reference pictures to be used for decoding a subsequent picture; and memory control means that control the picture storage means, wherein a frame size of the input pictures has been compared with $1/2$ of the maximum frame size of the pictures, and the maximum number of reconstructed pictures storable in a frame memory has been determined as 2 times of a maximum number of initially storable reconstructed pictures when the frame size of the input pictures is not more than $1/2$ of the maximum frame size of the pictures.

[0011] An aspect of the present disclosure provides a video predictive encoding device according to an aspect of the present disclosure comprises input means that inputs a plurality of

pictures forming a video sequence and encoding means that compresses the pictures, using either intra-frame prediction or inter-frame prediction, to generate compressed picture data including information about a target picture frame size, the maximum number of storable reconstructed pictures, and the maximum frame size specified as an encoding constraint, and encodes the compressed picture data along with encoding specification data regarding the information on the target picture frame size, the maximum number of storable reconstructed pictures, and the maximum frame size. The video predictive encoding device further comprises decoding means that decodes the compressed picture data to reconstruct the pictures, picture storage means that stores one or more of the reconstructed pictures as reference pictures to be used for encoding a subsequent picture, and memory control means that controls a picture buffer memory in the picture storage means, wherein when the frame size of the input pictures is not more than $1/(2^L)$ (where L is an integer of one or more) of the maximum frame size of pictures, the memory control means determines that (2^L) times the maximum number of reconstructed pictures are storable in the frame memory .

[0012] In this video predictive encoding device, the maximum number of reconstructed pictures storable in the picture buffer memory is determined, based on the relationship between the frame size associated with respective pictures forming the video sequence or the compressed picture data and the maximum frame size specified as an encoding constraint. More specifically, for example, when the frame size of the input pictures is larger than $1/(2^L)$ (where L is an integer of one or more) of the maximum frame size specified as an encoding constraint, the maximum number of storable reconstructed pictures is set to N (where N is an integer of one or more), whereas when the frame size of the input pictures is not more than $1/(2^L)$ of the maximum frame size, the memory buffer amount available for storing reconstructed pictures is controlled to allow storage of up to the $((2^L) \times N)$ number of reconstructed pictures. In this configuration, when the frame size of reconstructed pictures is not more than $1/(2^L)$ of the maximum frame size specified as an encoding setting, the maximum number of storable reconstructed pictures can be increased, and thus the number of storable reference pictures can

also be increased to thereby improve the coding efficiency.

[0013] In a video predictive encoding device according to another aspect of the present disclosure, the memory control means fixes memory pointers pointing storage positions of reconstructed pictures in the memory when determining the maximum number of reconstructed pictures storable in the frame memory.

[0014] In this video predictive encoding device, the memory pointers pointing the storage positions of the respective reconstructed pictures can be fixed, for example, at positions equal to the maximum frame size and $1/(2^L)$ thereof. Therefore, control is not needed to vary the memory pointers depending upon the frame sizes, and simpler implementation, more efficient memory control can be realized. Since pointer intervals are limited to multiples of $1/(2^L)$, the positions of the memory pointers may be calculated with a shift operation, and thus the calculation cost can be reduced.

[0015] A video predictive decoding device according to an aspect of the present disclosure comprises input means that inputs encoded data comprising compressed picture data which includes information on a target picture frame size, a maximum number of storable reconstructed pictures, and a maximum frame size specified as an encoding constraint, wherein a plurality of pictures constituting a video sequence has been compressed by either intra-frame prediction or inter-frame prediction. The video predictive decoding device further comprises decoding means that decodes the compressed picture data and the compressed picture data constituting the information on the target picture frame size, the maximum number of storable reconstructed pictures, and the maximum frame size to reconstruct pictures and the information on the target picture frame size, the maximum number of storable reconstructed pictures, and the maximum frame size. The device further comprises picture storage means that stores one or more of the reconstructed pictures as reference pictures to be used for decoding a subsequent picture and memory control means that controls the picture storage means, wherein when a frame size of the input pictures is not more than $1/(2^L)$ (where L is an integer of one or more)

of the maximum frame size of pictures, the memory control means determines that (2^L) times the maximum number of reconstructed pictures are storable in a frame memory .

[0016] In this video predictive decoding device, the maximum number of reconstructed pictures storable in the picture buffer memory is determined based on the relationship between the frame size associated with respective pictures forming the video sequence or the compressed picture data and the maximum frame size specified as an encoding constraint. More specifically, for example, when the frame size of the input pictures is larger than $1/(2^L)$ (where L is an integer of one or more) of the maximum frame size specified as an encoding constraint, the maximum number of storable reconstructed pictures is set to N (where N is an integer of one or more), whereas when the frame size of the input pictures is not more than $1/(2^L)$ of the maximum frame size, it is determined that up to the $(2^L) \times N$ number of reconstructed pictures are storable. In this configuration, when the frame size of reconstructed pictures is not more than $1/(2^L)$ of the maximum frame size specified as an encoding setting, the maximum number of storable reconstructed pictures can be increased, and thus the number of storable reference pictures can also be increased to thereby improve the coding efficiency.

[0017] In a video predictive decoding device according to another aspect of the present disclosure, the memory control means fixes the memory pointers pointing storage positions of reconstructed pictures in the frame memory, when determining the maximum number of reconstructed pictures storable in the frame memory.

[0018] In this video predictive decoding device, the memory pointers pointing the storage positions of the reconstructed pictures can be fixed, for example, at positions equal to the maximum frame size and $1/(2^L)$ thereof. Therefore, control is not needed to vary the memory pointers depending upon the frame sizes, and simpler implementation, more efficient memory control can be realized. Since pointer intervals are limited to multiples of $1/(2^L)$, the positions of the memory pointers can be calculated with a shift operation, and therefore the operation cost can be reduced.

[0019] A video prediction encoding method according to an aspect of the present disclosure is executed by a video predictive encoding device. The method comprises an input step of inputting a plurality of pictures forming a video sequence, and an encoding step of encoding the pictures by either intra-frame prediction or inter-frame prediction to generate compressed picture data including information on a target picture frame size, a maximum number of storable reconstructed pictures, and a maximum frame size specified as an encoding constraint, wherein the compressed picture data is compressed along with encoding specification data regarding the information on the target picture frame size, the maximum number of storable reconstructed pictures, and the maximum frame size. The method further comprises a decoding step of decoding the compressed picture data to reconstruct the pictures, a picture storage step of storing one or more of the reconstructed pictures as reference pictures to be used for encoding a subsequent picture, and a memory control step of controlling a picture buffer memory in the picture storage step, wherein when the frame size of the input pictures is not more than $1/(2^L)$ (where L is an integer of one or more) of the maximum frame size of pictures, the memory control step determines that (2^L) times the maximum number of reconstructed pictures are storable in the frame memory.

[0020] A video predictive encoding program according to an aspect of the present disclosure comprises an input module that inputs a plurality of pictures forming a video sequence and an encoding module that encodes the pictures by either intra-frame prediction or inter-frame prediction to generate compressed picture data including information on a target picture frame size, a maximum number of storable reconstructed pictures, and a maximum frame size specified as an encoding constraint and encodes the compressed picture data along with encoding specification data regarding the information on the target picture frame size, the maximum number of storable reconstructed pictures, and the maximum frame size. The program further comprises a decoding module that decodes the compressed picture data to reconstruct pictures, a picture storage module that stores one or more of the reconstructed pictures as reference pictures to be used for encoding a subsequent picture, and a memory

control module that controls a picture buffer memory in the picture storage module, wherein when the frame size of the input pictures is not more than $1/(2^L)$ (where L is an integer of one or more) of the maximum frame size of pictures, the memory control module determines that (2^L) times the maximum number of reconstructed pictures are storable in the frame memory.

[0021] The video predictive encoding method and the video predictive encoding program can achieve the same effects as the aforementioned video predictive encoding device.

[0022] A video predictive decoding method according to an aspect of the present disclosure is executed by a video predictive decoding device. The method comprises an input step of inputting encoded data comprising compressed picture data which includes a target picture frame size, a maximum number of storable reconstructed pictures, and a maximum frame size specified as an encoding constraint, wherein a plurality of pictures constituting a video sequence is compressed by either intra-frame prediction or inter-frame prediction. The method further comprises a decoding step of decoding the compressed picture data and the compressed picture data constituting the information on the target picture frame size, the maximum number of storable reconstructed pictures, and the maximum frame size to reconstruct pictures and the information on the target picture frame size, the maximum number of storable reconstructed pictures, and the maximum frame size. The method further comprises a picture storage step of storing, in picture storage means, one or more of the reconstructed pictures as reference pictures to be used for decoding a subsequent picture and a memory control step of controlling the picture storage means, wherein when the frame size of the input pictures is not more than $1/(2^L)$ (where L is an integer of one or more) of the maximum frame size of pictures, the memory control step determines that (2^L) times the maximum number of reconstructed pictures are storable in a frame memory.

[0023] A video predictive decoding program according to an aspect of the present disclosure comprises an input module that inputs encoded data comprising compressed picture data which includes a target picture frame size, a maximum number of storable reconstructed pictures, and

a maximum frame size specified as an encoding constraint, wherein a plurality of pictures constituting a video sequence is compressed either intra-frame prediction or inter-frame prediction. The program further comprises a decoding module that decodes the compressed picture data and that compressed picture data constituting the information on the target picture frame size, the maximum number of storable reconstructed pictures, and the maximum frame size to reconstruct pictures and the information on the target picture frame size, the maximum number of storable reconstructed pictures, and the maximum frame size. The program further comprises a picture storage module that stores one or more of the reconstructed pictures as reference pictures to be used for decoding a subsequent picture and a memory control module that controls the picture storage module, wherein when the frame size of the input pictures is not more than $1/(2^L)$ (where L is an integer of one or more) of the maximum frame size of pictures, the memory control module determines that (2^L) times the maximum number of reconstructed pictures are storable in a frame memory.

[0024] The video prediction decoding method and the video prediction decoding program can achieve the same effects as the aforementioned video prediction decoding device can achieve.

[0025] The video predictive encoding and decoding devices, methods, and programs according to aspects of the present disclosure perform determining the maximum number of reconstructed pictures storable in the picture buffer memory, according to the frame size of the reconstructed pictures, thereby achieving the efficient use of the picture buffer memory and also improving the encoding efficiency.

BRIEF DESCRIPTION OF THE DRAWINGS

[0026] Figs. 1(a) and 1(b) are drawings showing picture buffer memories, the number of storable pictures, and positions of variable memory pointers.

Figs. 2(a) and 2(b) are drawings for explaining a problem of fixed memory pointers in the picture buffer memory.

Fig. 3 is a block diagram showing a video predictive encoding device according to an embodiment of the present invention.

Fig. 4 is a block diagram showing a video predictive decoding device according to an embodiment of the present invention.

Fig. 5 is a flowchart showing first video predictive encoding and decoding methods according to an embodiment of the present invention.

Figs. 6(a) and 6(b) are schematic drawings for explaining processing of the first video predictive encoding and decoding methods according to the embodiment of the present invention.

Fig. 7 is a drawing showing a hardware configuration of a computer for executing a program recorded in a recording medium.

Fig. 8 is a perspective view of a computer for executing a program stored in a recording medium.

Embodiments of the Invention

[0027] Embodiments of the present invention will be described below using Figs. 3 to 8.

[0028] Fig. 3 is a block diagram showing a video predictive encoding device according to an embodiment of the present invention. Reference numeral 301 denotes an input terminal, 302 denotes a block division unit, 303 denotes a predictive signal generation unit, 304 denotes a frame memory, 305 denotes a subtraction unit, 306 denotes a transform unit, 307 denotes a quantization unit, 308 denotes a de-quantization unit, 309 denotes an inverse transform unit, 310 denotes an addition unit, 311 denotes an entropy encoding unit, 312 denotes an output terminal, and 314 denotes a frame memory management unit (or buffer management unit). The input

terminal 301 constitutes input means. The predictive signal generation unit 303, subtraction unit 305, transform unit 306, quantization unit 307, and entropy encoding unit 311 constitute encoding means. The de-quantization unit 308, inverse transform unit 309, and addition unit 310 constitute decoding means. The frame memory 304 constitutes picture storage means. The frame memory management unit 314 constitutes memory control means.

[0029] The operation of the video predictive encoding device configured as described above will be described below. A video signal representing a plurality of pictures is fed to the input terminal 301. A picture to be encoded (a “target picture”) is divided into a plurality of regions by the block division unit 302. In the embodiment according to the present invention, the target picture is divided into blocks each having 8×8 pixels, but it may be divided into blocks of any size or shape other than the foregoing. A predictive signal is then generated for a region to be encoded (referred hereinafter to as a target block). The embodiment according to the present invention employs two types of prediction methods. Namely, they are inter-frame prediction and intra-frame prediction.

[0030] In the inter-frame prediction, reconstructed pictures that have been encoded and thereafter restored are used as reference pictures, and the motion information that provides the predictive signal with the smallest error from the target block is determined from the reference pictures. This process is called motion detection. Depending upon situations, it is also allowable to subdivide the target block into sub-regions and perform inter-frame prediction on each of the sub-regions. In this process, the division method which gives rise to the most efficient result given the target block as a whole is selected from various division methods, and motion information of each sub-region is determined. In the embodiment according to the present invention, this operation is carried out in the predictive signal generation unit 303, to which the target block is fed via line L302, and reference pictures are fed via L304. The reference pictures to be used herein are a plurality of pictures which have been encoded and restored. The details of this operation are the same as the conventional technologies adopted in MPEG-2 or 4 and H.264. The motion information and the sub-region division method

determined as described above are fed via line L312 to the entropy encoding unit 311, encoded thereby and then output from the output terminal 312. Information (a reference index) identifying the reference picture among a plurality of reference pictures from which the predictive signal is generated is also sent via line L312 to the entropy encoding unit 311. In the embodiment according to the present invention, M reconstructed pictures (M is an integer of one or more) are stored in the frame memory 304 and are to be used as reference pictures. The predictive signal generation unit 303 acquires reference picture signals from the frame memory 304, based on the reference pictures and motion information, corresponding to the sub-region division method and each sub-region, and generates a predictive signal. The inter-frame predictive signal generated in this manner is fed via line L303 to the subtraction unit 305.

[0031] In the intra-frame prediction, an intra-frame predictive signal is generated using the values of previously reconstructed pixels spatially adjacent to the target block. Specifically, the predictive signal generation unit 303 acquires previously reconstructed pixel signals in the same frame from the frame memory 304 and extrapolates these signals to generate the intra-frame predictive signal. The information on the method of extrapolation is fed via line L312 to the entropy encoding unit 311, encoded thereby and output from the output terminal 312. The intra-frame predictive signal generated in this manner is fed to the subtraction unit 305. The method of generating the intra-frame predictive signal in the predictive signal generation unit 303 is a conventional technology adopted in H.264. One of the inter-frame predictive signal and the intra-frame predictive signal obtained as described above, which produces a smaller error, is selected, and the selected predictive signal is fed to the subtraction unit 305.

[0032] Since there are no pictures present prior to the first picture, all target blocks thereof are processed by intra-frame prediction.

[0033] The subtraction unit 305 subtracts the predictive signal (fed via line L303) from the signal of the target block (fed via line L302) to generate a residual signal. This residual signal is subjected to a discrete cosine transform by the transform unit 306, and then resulting

transform coefficients are quantized by the quantization unit 307. Finally, the entropy encoding unit 311 encodes the quantized transform coefficients, and the encoded data is output from the output terminal 312, along with the information on the prediction method.

[0034] In order to perform the intra-frame prediction or the inter-frame prediction on a subsequent target block, the compressed signal of the target block is inversely processed and restored. Namely, the quantized transform coefficients are inversely quantized by the de-quantization unit 308 and then subjected to an inverse discrete cosine transform by the inverse transform unit 309 to restore the residual signal. The addition unit 310 adds the restored residual signal to the predictive signal fed via line L303 to reconstruct a signal of the target block, which is stored in the frame memory 304. Although the present embodiment employs the transform unit 306 and the inverse transform unit 309, it is also possible to use other types of transform processing instead of these transform units. Depending upon situations, the transform unit 306 and the inverse transform unit 309 may be omitted.

[0035] The frame memory 304 is a finite storage and impossible to store all reconstructed pictures. Only the reconstructed pictures to be used for encoding subsequent picture are stored in the frame memory 304. The frame memory management unit 314 is the one that controls this frame memory 304. The frame memory management unit 314 controls the frame memory 304 so as to delete the oldest picture among the M reconstructed pictures (M is an integer of one or more) stored in the frame memory 304 such that the latest reconstructed picture can be stored as a reference picture. Through an input terminal 313, the frame size of each picture and the maximum frame size specified as an encoding constraint (profile and level) are fed, based on which the maximum number of reconstructed pictures storable in the frame memory is determined, and the frame memory management unit 314 operates to store reconstructed pictures within the maximum number. At the same time, the information on the frame size of each picture, the maximum frame size specified as an encoding constraint, and the maximum number of reconstructed pictures storable in the frame memory is fed via line L314 to the entropy encoding unit 311, encoded thereby, and output along with the compressed picture data.

The frame size, the maximum frame size specified as an encoding constraint, and the maximum number of reconstructed pictures storable in the frame memory are associated with each picture. The frame size may be expressed by a raw frame size value or may be expressed in the form of an exponent or a power. If the maximum frame size is specified in advance as profile and level information, the maximum frame size may be input using the information. It should be noted that in the present embodiment, the value of the frame size is directly converted into binary data, and the maximum frame size is specified as level information. It will be described later how the frame memory management unit 314 is controlled.

[0036] Next, the video predictive decoding method will be described. Fig. 4 is a block diagram showing a video predictive decoding device according to an embodiment of the present invention. Reference numeral 401 denotes an input terminal, 402 denotes a data analysis unit, 403 denotes a de-quantization unit, 404 denotes an inverse transform unit, 405 denotes an addition unit, 408 denotes a predictive signal generation unit, 407 denotes a frame memory, 406 denotes an output terminal, and 409 denotes a frame memory management unit. The input terminal 401 constitutes input means. The de-quantization unit 403 and inverse transform unit 404 constitute decoding means. Other types of decoding means may be employed instead of the foregoing. The frame memory 407 constitutes picture storage means. The frame memory management unit 409 constitutes memory control means. Furthermore, the decoding means may be configured without the inverse transform unit 404.

[0037] The operation of the video predictive decoding device configured as described above will be described below. Compressed data encoded as described above is input through the input terminal 401. The compressed data contains a residual signal resulting from the predictive encoding of each target block obtained by dividing a picture into a plurality of blocks, and the information on generation of a predictive signal. The information on generation of the predictive signal includes information on block division (size of block), motion information, and the aforementioned reference index when the inter-frame prediction was performed, or includes information on an extrapolation method performed on reconstructed surrounding pixels when

the intra-frame prediction was performed.

[0038] The data analysis unit 402 extracts, from the compressed data, the residual signal of the target block, the information on generation of the predictive signal, a quantization parameter, the frame size of pictures, the maximum frame size specified as an encoding constraint, and the maximum number of reconstructed pictures storable in the frame memory. The residual signal of the target block is inversely quantized with the quantization parameter (fed via line L402) by the de-quantization unit 403. The result is subjected to an inverse discrete cosine transform by the inverse transform unit 404.

[0039] Next, the information on generation of the predictive signal is fed via line L406b to the predictive signal generation unit 408. The predictive signal generation unit 408 accesses the frame memory 407, based on the information on generation of the predictive signal, to acquire a reference signal from a plurality of reference pictures in order to generate a predictive signal. This predictive signal is fed via line L408 to the addition unit 405. The addition unit 405 adds the predictive signal to the restored residual signal to reconstruct a target block signal, which is output via line L405 and simultaneously stored into the frame memory 407.

[0040] Reconstructed pictures to be used for decoding and reconstruction of a subsequent picture are stored in the frame memory 407. The frame memory management unit 409 controls the frame memory 407. The frame memory 407 is controlled so as to delete the oldest one among the stored M reconstructed pictures (M is an integer) such that the latest reconstructed picture used as a reference picture can be stored. The information on the frame size of the target picture, the maximum frame size specified as an encoding constraint, and the maximum number of reconstructed pictures storable in the frame memory are fed via line L406a to the frame memory management unit 409, based on which the frame memory management unit 409 operates. It will be described later how the frame memory management unit 409 is controlled.

[0041] The operations of the video predictive encoding method and the video predictive decoding method will be described below using Figs. 5 and 6. Fig. 5 is a flowchart showing the video predictive encoding and decoding methods according to an embodiment of the present invention. The variables noted in the same drawing will be explained. `pic_width` is a variable indicative of a luminance pixel count of a lateral width of the reconstructed pictures, `pic_height` is a variable indicative of a luminance pixel count of a vertical width of the reconstructed pictures, `MaxLumaFS` is a variable indicative of a maximum picture size defined by level information, `MFSBuffer` is a variable indicative of a memory buffer amount expressed by the maximum number of reconstructed pictures storable in the decoded picture buffer (DPB), which is defined as level information, `maxDPBsize` is a variable indicative of a memory buffer amount expressed by the maximum number of reconstructed pictures storable in the decoded picture buffer (DPB), `max_dec_pic_buffering` is a variable indicative of a maximum storage number (memory buffer amount) of reconstructed pictures used in decoding, and `DPBpointer` is a variable indicative of a pointer indicating a position of storage of a reconstructed picture in the decoded picture buffer.

[0042] In Fig. 5, input are the `pic_width` indicative of the luminance pixel count of the lateral width of the reconstructed pictures, the `pic_height` indicative of the luminance pixel count of the vertical width of the reconstructed pictures, the `MaxLumaFS` indicative of the maximum frame size specified as an encoding constraint, and the `MFSBuffer` indicative of the memory buffer amount expressed by the maximum number of reconstructed pictures storable in the decoded picture buffer (DPB). Next, a product of the `pic_width` indicative of the luminance pixel count of the lateral width of the reconstructed pictures and the `pic_height` indicative of the luminance pixel count of the vertical width of the reconstructed pictures in the input data is compared with a half ($\text{MaxLumaFS}/2$) of the `MaxLumaFS` indicative of the maximum picture size specified as an encoding constraint (step S502). If the condition is not met (or if the product of `pic_width` and `pic_height` is larger than the $\text{MaxLumaFS}/2$), `maxDPBsize = MFSBuffer` is set (step S503). If the condition is met (or if the product of `pic_width` and `pic_height` is not more than the

MaxLumaFS/2), maxDPBsize = 2*MFSBuffer is set (step S504).

(Operations)

$$\text{maxDPBsize} = 2 * \text{MFSBuffer} \text{ (if } \text{pic_width} * \text{pic_height} \leq (\text{MaxLumaFS} \gg 1))$$

$$\text{maxDPBsize} = \text{MFSBuffer} \text{ (otherwise)}$$

In the above operation ">>" represents a right shift operation and has the same meaning as MaxLumaFS/2.

[0043] Then, the memory buffer amount (max_dec_pic_buffering) expressed by the maximum storage number of reconstructed pictures used in decoding is set to not more than maxDPBsize.

(Operation)

$$\text{max_dec_pic_buffering} \leq \text{maxDPBsize}$$

[0044] If maxDPBsize = MFSBuffer, as shown in Fig. 6(a), DPBpointer = 1 is set to the head of the picture memory buffer, and DPBpointer = 2, 3, and 4 are set, respectively, to the positions distant from the position of DPBpointer = 1 by two times, three times and four times the maximum frame size.

[0045] If maxDPBsize = 2*MFSBuffer, as shown in Fig. 6(b), in addition to the DPB pointers 1 to 4 already set, further DPB pointers are set, respectively, to the positions distant from the position of DPBpointer = 1 by 1/2 times, 3/2 times, 5/2 times, and 7/2 times the maximum frame size from (step S505).

[0046] The max_dec_pic_buffering and DPB pointers so set are used in the control operation of the frame memory in step S508 as described below. Namely, during decoding, reconstructed pictures are stored in the frame memory up to the maximum number of

max_dec_pic_buffering, and when being stored, the reconstructed pictures are controlled to be stored based on the DPB pointers as set above. In encoding, information is given from the outside which includes information on the pic_width indicative of the luminance pixel count of the lateral width of the reconstructed pictures and the pic_height indicative of the luminance pixel count of the vertical width of the reconstructed pictures and level information on the MaxLumaFS indicative of the maximum picture size and the MFSBuffer indicative of the memory buffer amount expressed by the maximum number of reconstructed pictures storable in the decoded picture buffer (DPB). In Fig. 3, the information is fed via the input terminal 313 from a control device not shown.

[0047] On the other hand, in step S506, a target picture is encoded and then decoded by the method described with Fig. 3. The encoded picture data is output to the outside or stored. It is determined in step S507 whether the target picture is to be used as a reference picture in the subsequent processing. The determination in step S507 depends on how the picture is encoded (intra-frame prediction encoding, inter-frame prediction encoding, or bidirectional prediction encoding). When the target picture is not used as a reference picture, the flow goes to step S510. When the target picture is used as a reference picture, the flow goes to step S508, where the DPB pointers are set to the positions shown in Fig. 6(a) or 6(b). Then, the decoded and reconstructed picture is stored in the frame memory in step S509, and the flow goes to step S511. If there is a next picture in step S511, the flow goes to S506, whereas if there is no next picture the process is terminated. The encoding process is executed through the last picture in this manner.

[0048] The above-described processes are performed in the entire video encoding device shown in Fig. 3. Specifically, the steps S502, S503, S504, S505, and S508 are carried out in the frame memory management unit 314.

[0049] The process shown in Fig. 5 was described above as a video encoding method, but it is applicable to the processing of a video decoding method. When decoding is performed, in step

S501, compressed and encoded picture data (bit stream) is input. Extracted from the input data are the `pic_width` indicative of the luminance pixel count of the lateral width of the reconstructed pictures, the `pic_height` indicative of the luminance pixel count of the vertical width of the reconstructed pictures, the `MaxLumaFS` indicative of the maximum frame size specified as an encoding constraint, the `MFSBuffer` indicative of the memory buffer amount expressed by the maximum number of reconstructed pictures storable in the decoded picture buffer (DPB), and the `max_dec_pic_buffering` indicative of the maximum storage number (memory buffer amount) of reconstructed pictures used in decoding, and the steps S502-S505 and S508 are carried as described above. On the decoding side, it is checked in step S505 whether the restored `max_dec_pic_buffering` is not more than the `maxDPBsize`. In Step S506, the compressed data of the target picture is decoded to restore the picture. Step S507 and the subsequent steps are performed as described above. These processes are performed in the video decoding device shown in Fig. 4. Specifically, steps S502, S503, S504, S505, and S508 are carried out in the frame memory management unit 409 of the video decoding device.

[0050] Figs. 6(a) and 6(b) are schematic diagrams for explaining the positions of the memory pointers in the frame memory implemented in the video predictive encoding and decoding methods according to the embodiment of the present invention. A comparison between Figs. 6(a) and 6(b) reveals that the positions of the memory pointers 1 to 4 are fixed. When the condition in step S503 is met, the new memory pointers 5 to 8 are added. Namely, regardless of the determination result in step S503, the positions of the memory pointers are fixed.

[0051] (Positions of Memory Pointers)

In the present embodiment, the memory pointer 1 to 4 and 5 to 8 are alternately set, but the memory pointers may be assigned numbers incremental from 1 to 8.

[0052] (Number of Memory Divisions)

In the present embodiment, the `pic_width` indicative of the luminance pixel count of

the lateral width of the reconstructed pictures and the `pic_height` indicative of the luminance pixel count of the vertical width of the reconstructed pictures are compared with a half ($\text{MaxLumaFS}/2$) of the `MaxLumaFS` indicative of the maximum frame size specified as an encoding constraint. It should however be noted that the `pic_width` indicative of the luminance pixel count of the lateral width of the reconstructed pictures and the `pic_height` indicative of the luminance pixel count of the vertical width of the reconstructed pictures may be compared with the maximum frame size $\text{MaxLumaFS}/(2^L)$ (where L is an integer of 2 or more) specified as an encoding constraint. When so compared, the positions of the memory pointers pointing the storage positions of reconstructed pictures may be set so that the memory pointers are arranged at positions determined by $1/(2^L)$ of `MaxLumaFS` while the pointers already arranged are fixed, as shown in Figs. 6(a) and 6(b).

[0053] (Definition of Frame Size)

In the present embodiment, the frame size is expressed by the `pic_width` indicative of the luminance pixel count of the lateral width of the reconstructed pictures and the `pic_height` indicative of the luminance pixel count of the vertical width of the reconstructed pictures. It should however be noted that it is also possible to use a value indicative of the already multiplied value which means frame size. The frame size may also be calculated by a method other than the above.

[0054] In the present embodiment, the `MaxLumaFS` indicative of the maximum picture size and the `MFSBuffer` indicative of the memory buffer amount expressed by the maximum number of reconstructed pictures having the size of `MaxLumaFS` storable in the decoded picture buffer (DPB) are specified as level information. It should however be noted that they need not be transmitted as the level information. They may be added as information other than the level information.

[0055] In the present embodiment, `FSBuffer` and `maxDPBsize` are expressed by the maximum

number of storable reconstructed pictures. It should however be noted that they may be expressed as the actual memory amount. If so expressed, the number of reconstructed pictures is calculated by dividing the memory amount with the frame size.

[0056] Since the maximum number of reconstructed pictures storable in the picture buffer memory is determined, based on the relationship between the picture frame size and the maximum frame size specified as an encoding constraint, when the actual frame size is smaller than the maximum frame size, a waste of the frame memory can be reduced, and memory regions for storing reference pictures can be increased to thereby enable further improvement of the coding efficiency.

[0057] A video predictive encoding program and a video predictive decoding program for a computer to function as the foregoing video predictive encoding device and video predictive decoding device may be provided as programs stored in a recording medium. Examples of such recording media include recording media such as floppy (registered trademark) disks, CD-ROMs, DVDs, and ROMs, semiconductor memories, and the like.

[0058] Specifically, the video predictive encoding program is provided with an input module that implements input of a plurality of pictures constituting a video sequence, an encoding module that encodes the pictures by either intra-frame prediction or inter-frame prediction to generate compressed picture data including information on the target picture frame size, a maximum number of storable reconstructed pictures, and a maximum frame size as an encoding setting, and to encode the compressed picture data along with encoding specification data regarding the information on the target picture frame size, the maximum number of storable reconstructed pictures, and the maximum frame size, a decoding module that decodes the compressed picture data to reproduce pictures, a picture storage module that stores one or more of the reconstructed pictures as reference pictures to be used for encoding a subsequent picture, and a memory control module that controls a picture buffer memory in the picture storage module, wherein when a frame size of the input pictures is not more than $1/(2^L)$ (where L is an

integer of one or more) of the maximum frame size of pictures, the memory control module determines that (2^L) times the maximum number of reconstructed pictures are storable in the frame memory.

[0059] The video predictive decoding program is provided with an input module that implements input of encoded data comprising compressed picture data which includes information on the target picture frame size, a maximum number of storable reconstructed pictures, and a maximum frame size as an encoding setting, wherein a plurality of pictures constituting a video sequence are encoded by either intra-frame prediction or inter-frame prediction, a decoding module that decodes the compressed picture data and the compressed picture data constituting the information on the target picture frame size, the maximum number of storable reconstructed pictures, and the maximum frame size to restore reconstructed pictures and the information on the target picture frame size, the maximum number of storable reconstructed pictures, and the maximum frame size, a picture storage module that stores one or more of the reconstructed pictures as reference pictures to be used for decoding a subsequent picture, and a memory control module that controls the picture storage module, wherein when a frame size of the input pictures is not more than $1/(2^L)$ (where L is an integer of one or more) of the maximum frame size of pictures, the memory control module determines that (2^L) times the maximum number of reconstructed pictures are storable in the frame memory.

[0060] Fig. 7 is a drawing showing a hardware configuration of a computer for executing the program recorded in a recording medium and Fig. 8 a perspective view of a computer for executing the program stored in a recording medium. The computer includes a DVD player, a set-top box, a cell phone, etc. provided with a CPU and configured to perform processes and control by software.

[0061] As shown in Fig. 7, the computer 30 is provided with a reading device 12 such as a floppy (registered trademark) disk drive unit, a CD-ROM drive unit, or a DVD drive unit, a working memory (RAM) 14 on which an operating system is resident, a memory 16 for storing

programs stored in the recording medium 10, a monitor unit 18 like a display, a mouse 20 and a keyboard 22 as input devices, a communication device 24 for transmission and reception of data or the like, and a CPU 26 for controlling execution of programs. When the recording medium 10 is put into the reading device 12, the computer 30 becomes accessible to the video prediction encoding or decoding program stored in the recording medium 10 through the reading device 12 and becomes able to operate as the video predictive encoding or decoding device according to the present invention, based on the video predictive encoding or decoding program.

[0062] As shown in Fig. 8, the video predictive encoding program or the video predictive decoding program may be provided in the form of computer data signal 40 superimposed on a carrier wave, through a network. In this case, the computer 30 can execute the video predictive encoding program or the video predictive decoding program after the video predictive encoding program or the video predictive decoding program received by the communication device 24 is stored into the memory 16.

List of Reference Signs

[0063] 301 input terminal; 302 block division unit; 303 predictive signal generation unit; 304 frame memory; 305 subtraction unit; 306 transform unit; 307 quantization unit; 308 de-quantization unit; 309 inverse transform unit; 310 addition unit; 311 entropy encoding unit; 312 output terminal; 313 input terminal; 314 frame memory management unit; 401 input terminal; 402 data analysis unit; 403 de-quantization unit; 404 inverse transform unit; 405 addition unit; 406 output terminal; 407 frame memory; 408 predictive signal generation unit; 409 frame memory management unit.

CLAIMS:

1. A video predictive decoding method executed by a video predictive decoding device, comprising:

an input step of inputting encoded data comprising compressed picture data which includes information on a target picture frame size, a maximum number of storable reconstructed pictures, and a maximum frame size specified as an encoding constraint, wherein a plurality of pictures forming a video sequence are encoded by either intra-frame prediction or inter-frame prediction;

a decoding step of decoding the compressed picture data, and the compressed picture data indicating the information on the target picture frame size, the maximum number of storable reconstructed pictures and the maximum frame size, to reconstruct the pictures, and the information on the target picture frame size, the maximum number of storable reconstructed pictures and the maximum frame size;

a picture storage step of storing in picture storage means one or more of the reconstructed pictures as reference pictures to be used for decoding a subsequent picture; and

a memory control step of controlling the picture storage means,

wherein a frame size of the input pictures has been compared with $1/2$ of the maximum frame size of the pictures, and the maximum number of reconstructed pictures storable in a frame memory has been determined as 2 times of a maximum number of initially storable reconstructed pictures when the frame size of the input pictures is not more than $1/2$ of the maximum frame size of the pictures.

2. A video predictive decoding device comprising:

input means that inputs encoded data comprising compressed picture data which includes information on a target picture frame size, a maximum number of storable reconstructed pictures, and a maximum frame size specified as an encoding constraint, wherein a plurality of pictures forming a video sequence are encoded by either intra-frame prediction or

inter-frame prediction;

decoding means that decodes the compressed picture data, and the compressed picture data indicating the information on the target picture frame size, the maximum number of storable reconstructed pictures and the maximum frame size, to reconstruct the pictures, and the information on the target picture frame size, the maximum number of storable reconstructed pictures and the maximum frame size;

picture storage means that stores one or more of the reconstructed pictures as reference pictures to be used for decoding a subsequent picture; and

memory control means that control the picture storage means,

wherein a frame size of the input pictures has been compared with $1/2$ of the maximum frame size of the pictures, and the maximum number of reconstructed pictures storable in a frame memory has been determined as 2 times of a maximum number of initially storable reconstructed pictures when the frame size of the input pictures is not more than $1/2$ of the maximum frame size of the pictures.

NTT DOCOMO, INC.

Patent Attorneys for the Applicant

SPRUSON & FERGUSON

Fig.2

(a) IN THE CASE OF FRAME SIZE
= MAXIMUM FRAME SIZE

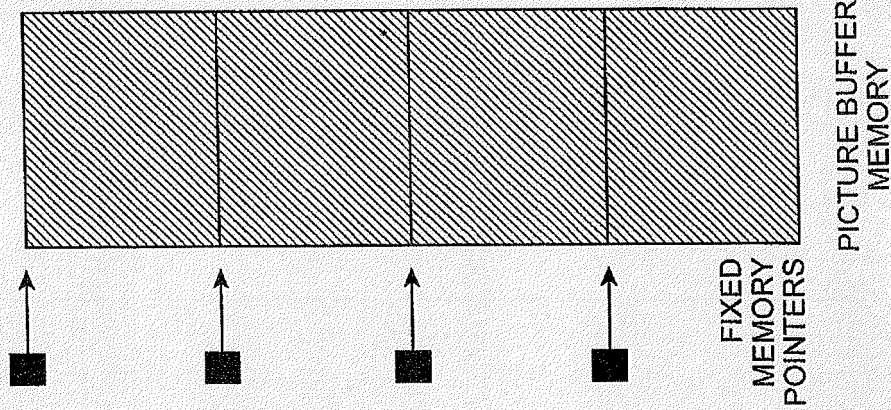

(b) IN THE CASE OF FRAME SIZE
< MAXIMUM FRAME SIZE

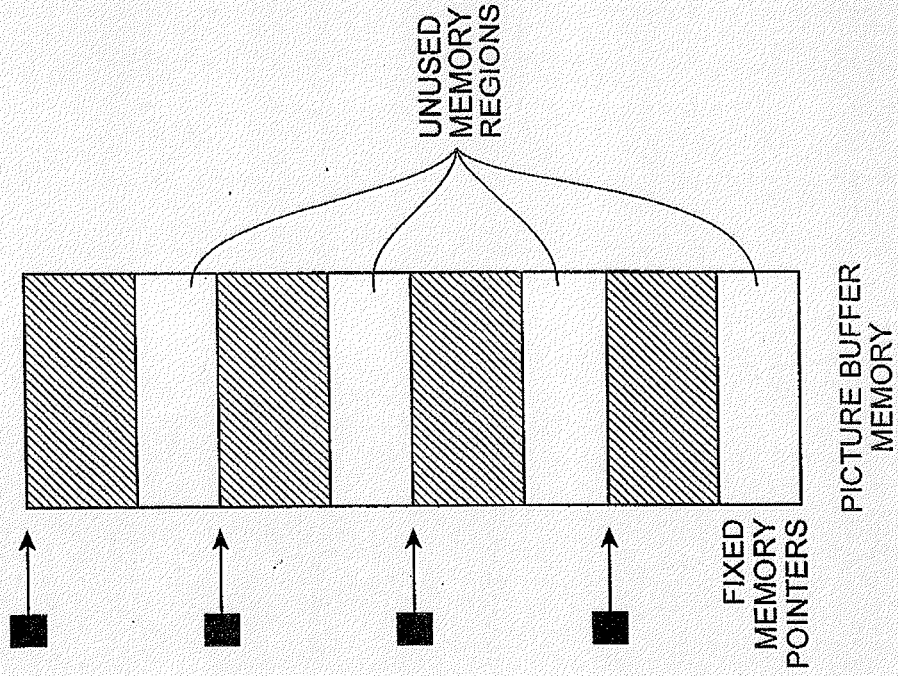

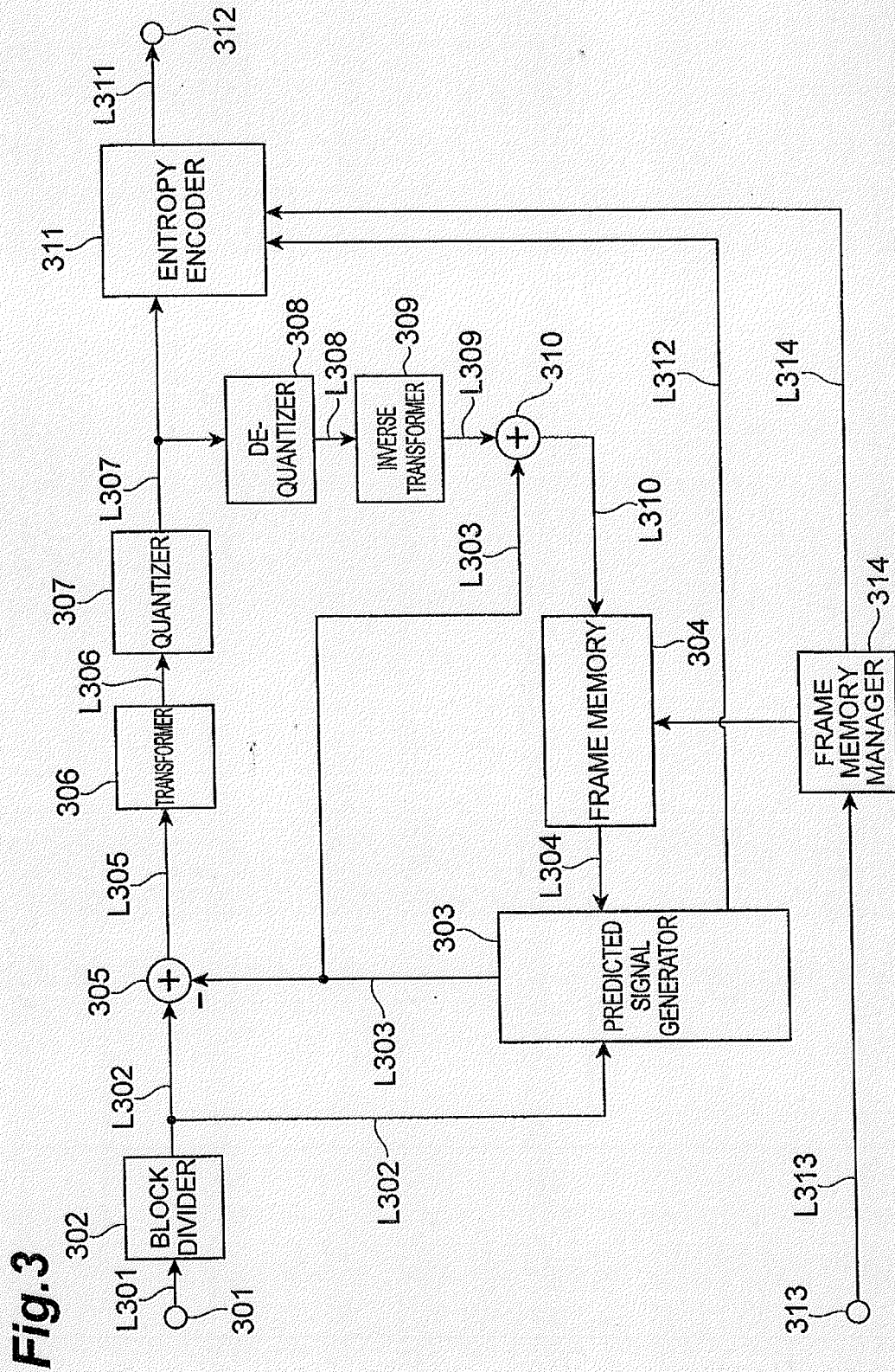

Fig.4

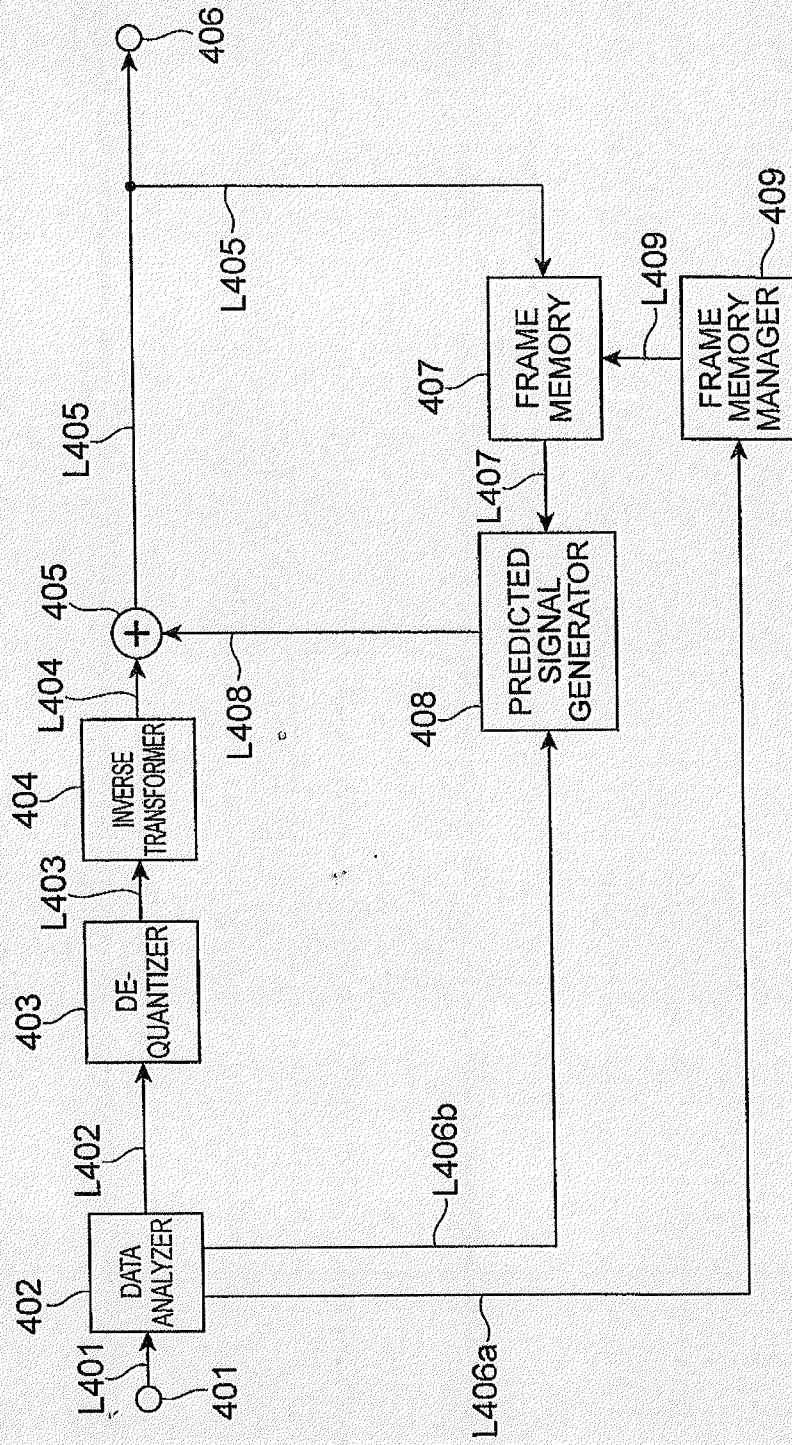

Fig.5

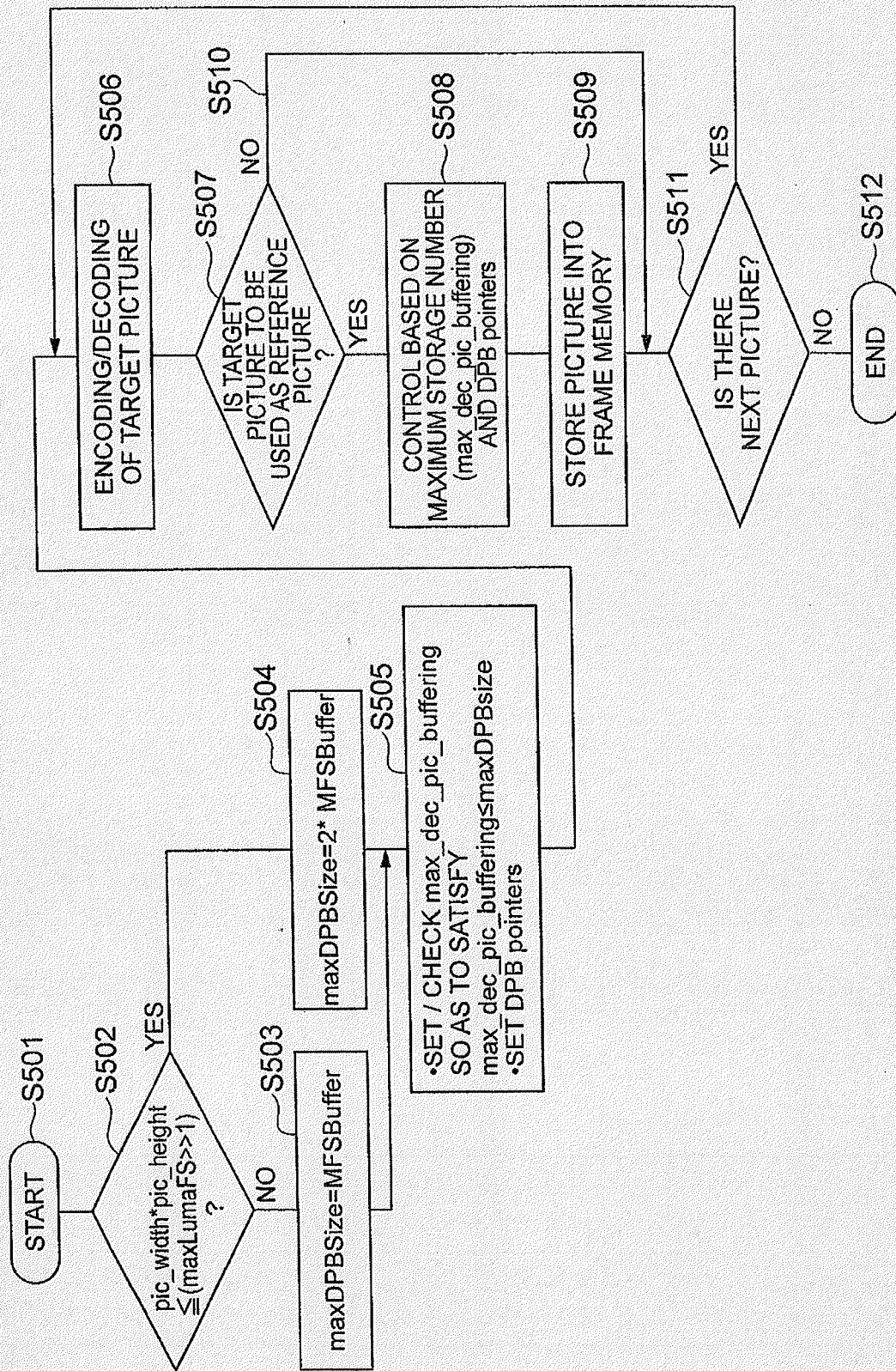

Fig.6

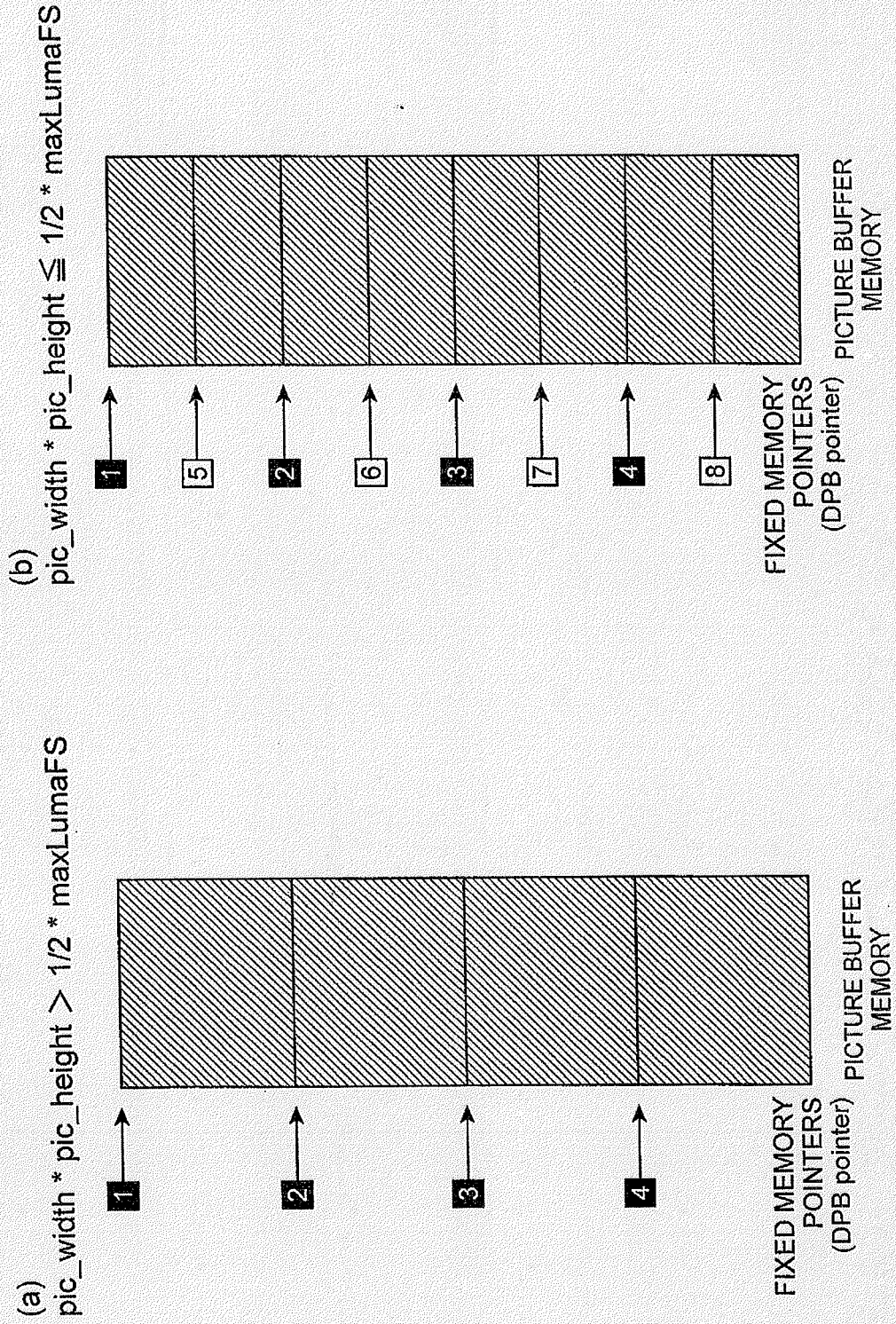

Fig.7

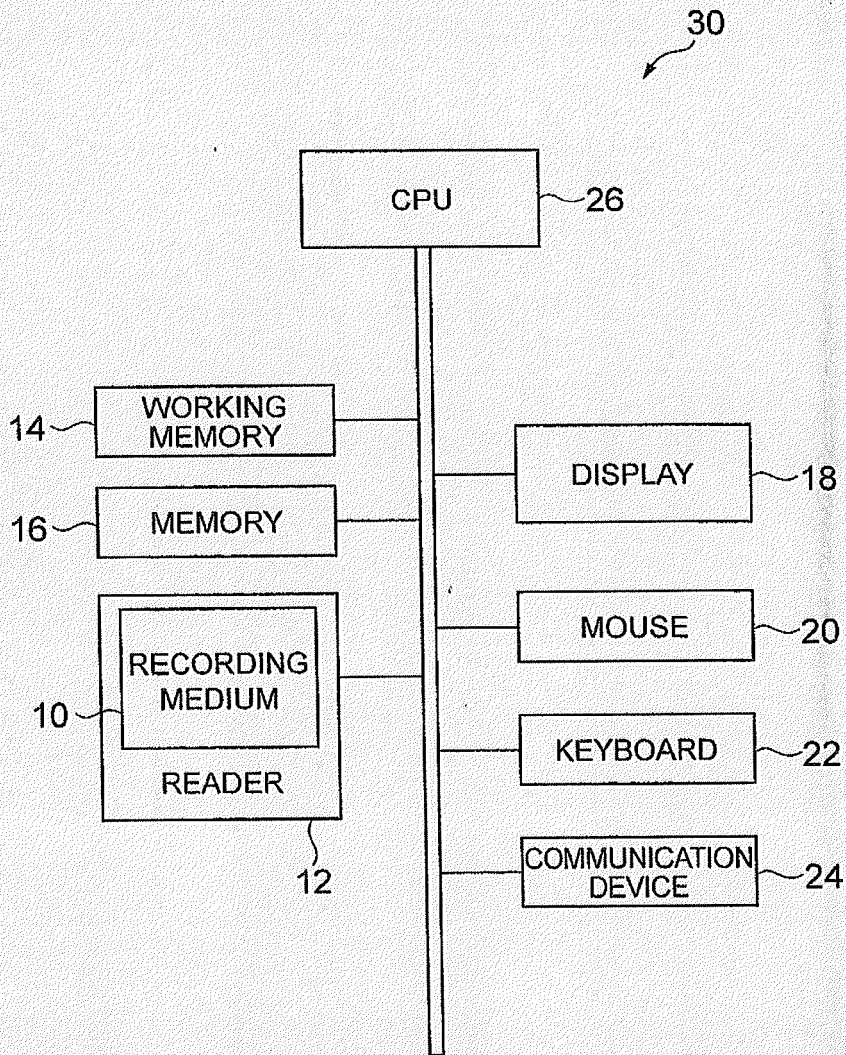

Fig.8

