



Europäisches Patentamt
European Patent Office
Office européen des brevets



(11) **EP 1 218 247 B1**

(12) **EUROPEAN PATENT SPECIFICATION**

(45) Date of publication and mention
of the grant of the patent:

02.03.2005 Bulletin 2005/09

(21) Application number: **99970641.9**

(22) Date of filing: **21.10.1999**

(51) Int Cl.7: **B65D 5/54**

(86) International application number:
PCT/US1999/024655

(87) International publication number:
WO 2000/023334 (27.04.2000 Gazette 2000/17)

(54) **CARTON AND CARTON BLANK**

KARTON UND KARTONZUSCHNITT

EMBALLAGE EN CARTON ET SON EBAUCHE

(84) Designated Contracting States:
**AT BE CH CY DE DK ES FI FR GB GR IE IT LI LU
MC NL PT SE**

(30) Priority: **21.10.1998 GB 9822971**
05.07.1999 GB 9915632

(43) Date of publication of application:
03.07.2002 Bulletin 2002/27

(73) Proprietor: **MeadWestvaco Packaging Systems
LLC**
Stamford, Connecticut 06905 (US)

(72) Inventors:
• **AUCLAIR, Jean-Michel**
F-36000 Chateauroux (FR)

• **GARNIER, Jean-Michel**
F-36100 Issoudun (FR)

(74) Representative: **Hepworth, John Malcolm et al**
Hepworth Lawrence Bryer & Bizley
Bloxam Court
Corporation Street
Rugby, Warwickshire CV21 2DU (GB)

(56) References cited:
CH-A- 527 735 **DE-A- 19 834 947**
US-A- 1 988 582 **US-A- 3 640 446**
US-A- 4 215 783

EP 1 218 247 B1

Note: Within nine months from the publication of the mention of the grant of the European patent, any person may give notice to the European Patent Office of opposition to the European patent granted. Notice of opposition shall be filed in a written reasoned statement. It shall not be deemed to have been filed until the opposition fee has been paid. (Art. 99(1) European Patent Convention).

Description

Background of the Invention

[0001] The invention relates to a carton or sleeve for accommodating one or more articles for example information discs or the like formed from one or more blanks of paperboard or other suitable foldable sheet material and more particularly to a sleeve capable of being formed into a sealed compartment including a cover flap with mean for releasably fastening the cover flap to the carton.

[0002] The invention is particularly useful where it is desirable for cartons containing articles to be enclosed to protect the or each article, for example information discs or foodstuffs. Furthermore, the carton should preferably be reclosable to allow it to be reused.

[0003] One example of reclosable sleeves formed from one or more blanks of cardboard is found in US 3,078,030 which illustrates a carton having integral hinged top that it reclosable. The top is provided by a front cover panel and a spacer panel secured to one side of the front cover panel to interfit with a mating upper portion of the front panel of a box. Fastening means is formed from a detached double layer portion of the front panel. However, the detached portion is attached to the inside surface of the cover flap resulting in a stepped non-flat front surface.

[0004] In US 3,894,680 there is provided a dispensing spout in a carton box adapted to accommodate powdery materials, for example detergents, which spout is adapted to keep closed after it has been cut out. The fastening means is formed from a detached triple layer portion of the front panel but it does not define a pocket to retain the spout.

Summary of the Invention

[0005] The present invention and its preferred embodiments seek to overcome or at least mitigate the problems of the prior art.

[0006] According to a first aspect of the invention there is provided a sleeve for holding information discs or the like, comprising a reclosable cover flap to close the open end and a front face of the sleeve said cover flap being frangibly connected at one of its ends to the said front face when closed and including fastening means to cooperate with a panel of said front face to reclose the sleeve after opening, the fastening means being engaged by relative sliding movement between said cover flap and said one front panel.

[0007] According to an optional feature of this aspect of the invention the fastening means may comprise a double layer tab on the front panel and when detached said double layer tab defines between its outer layer and said front panel a pocket for receiving a complementary portion of the cover flap. Preferably, the pocket may be formed between a protruding portion of the outer layer

of said double layer tab and said front panel.

[0008] According to another optional feature of this aspect of the invention the cover flap may be two ply such that said complementary portion comprises a protruding portion of the inner layer of said cover flap so as to provide a fully flat front face.

[0009] According to a further optional feature of this aspect of the invention the frangible connection may be provided by a first frangible line connecting the inner layer of said two ply portion to the cover flap and a second frangible line connecting the outer layer of said two ply portion to the cover flap, the first frangible line being tapered outwardly relative the second frangible line to define said pocket and said complementary portion.

[0010] A second aspect of the present invention provides a blank for forming a sleeve for holding information discs or the like comprising back panel, opposed side and end panels hingedly connected to said back panel, a front panel hingedly connected to one of said end panels and a cover flap hingedly connected to the opposing one of said end panels and capable of relative slidable movement with said front panel and fastening means constructed and arranged to define a pocket for receiving the free edge of the cover flap when the sleeve is set up.

[0011] According to an optional feature of the second aspect of the invention the fastening means may comprise a pair of tab panels frangibly connected by frangible connection means to the cover flap and hingedly connected together to be capable of defining a two ply portion adapted to be secured to the front panel.

[0012] According to an optional feature of this second aspect of the invention the cover flap may comprise inner and outer panels hingedly connected together along an end edge.

[0013] A third aspect of the invention provides a carton for holding one or more articles, for example frozen foodstuffs or the like, comprising a reclosable access flap to close parts of a double ply carton wall. The access flap is frangibly connected at one of its ends to the carton wall when closed and includes fastening means to cooperate with a panel of the carton wall to reclose the carton after opening.

[0014] According to an optional feature of this aspect of the invention, the reclosable access flap is a double ply structure and the inner and outer layers of the access flap are connected to inner and outer layers of the double layer carton wall along first and second frangible lines wherein a portion of the first frangible line is offset from the second frangible line so that when the access flap is severed from the carton wall along the first and second frangible lines the offset portion of the first frangible line defines a locking tab of the fastening means for engaging the outer layer of the carton wall.

[0015] Preferably, a portion of the second frangible line defines a second locking tab offset the first locking tab and a pocket for engaging part of the first locking tab. More preferably, the pocket is formed by a portion

of the outer layer of said carton wall panel protruding into a recess formed in the inner carton wall panel for receiving the first locking tab.

[0016] According to another optional feature of this aspect of the invention, the inner and outer walls of the access flap are frangibly connected to be severed when the access flap is severed from the carton wall. Optionally, the access flap further comprises securing means for detachably connecting the inner and outer panels of the access flap together.

[0017] A fourth aspect of the invention provides a blank for forming a carton for holding one or more articles comprising a top wall panel, a base wall panel, opposed side panels hingedly connected together in series and end wall panels. There further comprises an access flap hingedly connected to the top and base wall panels and fastening means so constructed and arranged to define a pocket for receiving part of the access flap when the carton is set up.

[0018] According to an optional feature of this aspect of the invention, the fastening means comprises a locking tab panel frangibly connected by frangible connection means to the adjacent side wall.

[0019] According to another optional feature of this aspect of the invention, the access flap comprises inner and outer panels hingedly connected to the top and bottom wall panels respectively along an end edge.

Brief Description of the Drawings

[0020] Exemplary embodiments of the invention will now be described, by way of example only, with reference to the accompanying drawings in which:

Figure 1 is plan view of a blank for forming a carton according to a first embodiment of the invention;

Figures 2 and 3 illustrate the blank of Figure 1 shown during the folding process;

Figure 4 is a perspective view of the carton formed from the blank illustrated in Figure 1 in a set-up and loaded condition;

Figure 5 is a perspective view of the carton shown in Figure 4 during use;

FIGURE 6 illustrates a blank according to a second embodiment of the invention;

FIGURES 7, 8 and 9 are perspective views of a carton erected from the blank shown in Figure 6 and illustrating the various stages for opening the reclosable access flap of the second embodiment of the invention;

FIGURE 9a illustrates a perspective view of the carton shown in Figure 7 with the reclosable access

flap being reclosed;

FIGURES 10a, 10b and 10c are perspective views of the third embodiment of the reclosable access flap;

FIGURES 11, 12 and 13 illustrates a fourth embodiment of the reclosable access flap of the present invention;

FIGURE 14 is a blank according to the fifth embodiment of the invention; and

FIGURES 15 and 16 are perspective views of the carton formed from the blank shown in Figure 14.

Detailed Description of the Preferred Embodiments

[0021] Referring first to Figure 1, there is shown a blank 10 for forming a carton (or sleeve) made from one or more blanks of paperboard or similar foldable sheet material. The sleeve is adapted to hold one or more information discs. In this embodiment, the blank 10 comprises a back panel 12, opposed side panels 14 and 22 hingedly connected to back panel 12 along fold lines 16 and 24 respectively. There may further comprise opposed end panels 18 and 26 hingedly connected to the opposed end edges of back panel 12 along fold lines 20 and 28. In this embodiment, the back panel is substantially square to conform to the shape of the disc. It is envisaged that other shapes of the base panel and/or sleeve can be adopted according to the shape and/or size of the article to be contained.

[0022] Preferably, a front panel 30 is hingedly connected to the outer edge of end panel 26 along lateral fold line 32. In this embodiment there may further comprise a pair of side support flaps 34 and 38 hingedly connected to the outer edges of side panels 14 and 22 respectively along longitudinal fold lines 36 and 40.

[0023] One aspect of the invention provides a cover flap fastening means to reclose the sleeve after opening. The cover flap 42 is provided to cover the front face of the carton. In this embodiment, it is hingedly connected to the outer edge of end panel 18 along lateral fold line 44. Optionally, an inner cover flap 46 is hingedly connected to outer cover flap 42 along its end edge defined by fold line 48, wherein the inner cover flap corresponds in shape to the outer cover flap.

[0024] One type of fastening means is provided by a pair of securing panels 54, 56 hingedly connected together about fold line 48 and capable of being folded to define a two ply tab. Figure 1 illustrates securing panel 54 detachably connected to cover flap 42 along frangible line 50 and securing panel 56 detachably connected to inner cover flap 46 along fold line 61. Preferably, a second pair of securing panels 58 and 60 that are connected to cover flaps 42 and 46 along frangible lines 52 and 63 respectively. The shape of each pair of securing

panels 54, 56 and 58, 60 defines end tabs 72 and 73 extending outwardly from cover flaps 42 and 46 respectively. Panels 58 and 60 are hingedly connected together along fold line 48. Securing panel 58 is connected to cover flap 42 along frangible line 52 and securing panel 60 is connected to inner cover flap 46 along frangible line 63.

[0025] It will be seen from Figure 1, that the configuration of frangible lines 50 and 52 differ from frangible lines 61 and 63. Accordingly, securing panels 54 and 58 comprise a protruding portion 62 and panels 56, 60 include a tapered portion 64. Thus, end tab 72 of outer cover flap 42 is defined along its side edges by frangible lines 50, 52 and is provided with a recess and, second end tab 73 extending from inner cover flap 46 has its side edges defined by frangible lines 61, 63 to taper outwardly at the base 64 of the tab neck.

[0026] The construction of the carton is illustrated with reference to Figures 2 and 3: the inner cover flap 46 and securing panels 56, 60 are first folded about fold line 48 to be secured in face-contacting relationship with outer cover flap 42 and securing panels 54, 58 respectively to form a two ply cover flap and a double layer tab 72, 73. In this embodiment, securing means is provided by glue 66 applied to outer side portions of inner cover flap 46 and the tab panels 56, 60. Cover flap 46 is folded in direction A about fold line 48 shown in Figure 2.

[0027] The carton is then loaded with one or more articles such that the article is placed on the back panel by hand or automatic machinery and side panels 14 and 22 and side support flaps 34 and 38 respectively are folded inwardly in direction B into spaced, overlapping relationship with back panel 12, illustrated in Figure 3. Thereafter, end panel 26 and front panel 30 are folded inwardly in direction C about fold lines 28 and 32 respectively into a spaced overlapping relationship with back panel 12 and front panel is secured to side support flaps 34, 38 by glue or other suitable means known in the art. In this embodiment, glue is applied to side support flaps 34, 38 at location 71 to be secured to the front panel 30.

[0028] Finally, the two-ply cover flap 42, 46 and end panel 18 are folded inwardly in direction D about fold lines 20 and 44 respectively to form the front face of the carton and panels 56 and 60 are secured to front panel 30, preferably, by glue applied at locations 68 or other suitable means known in the art.

[0029] Thus, the carton is in its completed form with an article, for example information disc or the like held in the sleeve as shown in Figure 4.

[0030] It is envisaged that the carton or sleeve of the present invention can be formed by a series of sequential folding and gluing operations which can be formed in a straight-line machine so that the carton is not required to be rotated or inverted to complete its construction. The folding process is not limited to that described below and can be altered according to particular manufacturing or user requirements. For example, the sleeve could be part constructed whereby side flaps and front

panel are secured together (after folding operations B and C) before loading it with articles. Alternatively, it is envisaged that the carton could be supplied fully constructed in a flat collapsed condition with one of the side or end panels unsecured along one edge to provide an aperture in the side or to end load the sleeve with the or each article.

[0031] It will be seen from Figure 4 that there comprises a sleeve 70 for holding information discs or the like comprising a reclosable cover flap 42/46 to close the open end and a front opening of the sleeve, the cover flap 42/46 including fastening means 76 detachably connected to the cover flap 42/46 and glued to the front panel 30. After detached from the cover flap 42/46, the fastening means 76 can be engaged again by the cover flap 42/46 by relative sliding movement between the cover flap 42/46 and the front panel 30, as shown in Figure 5.

[0032] Turning in detail to the reclosable feature of the embodiment of the present invention, shown in Figure 5, the fastening means 76 comprises a double layer securing panel 54, 56 on the front panel 30 and, when detached, the double layer panel 54, 56 defines between its outer layer 54 and the front panel 30 a pocket 78 for receiving a complementary portion 80 of the cover flap 42/46. It will be seen the pocket 78 is defined by frangible lines 50 and 52 and frangible lines 61 and 63 respectively. The complementary portion 80 of the cover flap 42/46 is formed by the recessed portion 82 and the corresponding outwardly tapered portion of the inner ply 46 to be received in the pocket 78. Thus, the cover flap 42/46 is adapted to be engaged by the double layer panel 54, 56 on the front panel 30 by relative sliding movement between the flap 42/46 and the panel 30.

[0033] Turning to the second embodiment illustrated in Figures 6 to 9a there is shown a carton for packaging one or more articles, for example for frozen food or chilled foodstuffs. The blank 108 is formed from paperboard or similar foldable sheet material for example plastic or the like. In the second embodiment, the carton comprises an outer side wall panel 110, a top wall panel 112, a second side wall panel 114, a base wall panel 116 and an inner side wall panel 118 hingedly connected together in series along fold lines 120, 122, 124 and 126 respectively.

[0034] There may further comprises an end closure structure hingedly connected to opposing lateral ends of the blank 108. Each end closure structure, in this embodiment, comprises an outer end wall panel 128 and an inner end wall panel 130 hingedly connected to top and base wall panels 112 and 116 respectively along fold lines 132 and 134. In use, the outer and inner end wall panels 128, 130 are configured to overlap when in a set up condition. One or more of the end wall panels may further comprise a gusset panel structure for interconnecting the respective end wall panel to the adjacent side wall panel. It will be seen from Figure 6 that there may comprise a pair of gusset panel structures 136, 142

hingedly connected to inner end wall panel 130 along its opposing side edges by an extension of fold lines 124 and 126 respectively.

[0035] Each gusset panel structure 136, 142 may comprise a pair of panels 137, 139 hingedly connected to the respective side wall panels 114, 118 along fold lines 138 and 144 respectively. The gusset panels 137, 139 are connected together by a fold line 146 oriented at an acute angle with respect to fold lines 124 and 126 respectively to define triangular gusset panels 137, 139. The triangular panels 137, 139 can be folded into face contacting relationship with each other during carton set up.

[0036] The opposing end structure is substantially the same as that described above with like panels being designated by the same reference numerals with the letter "a" added to the reference and is not, therefore, described in any greater detail.

[0037] Referring to Figure 7, a reclosable access flap structure 148 is provided, according to one class of embodiments of the invention, and is illustrated in more detail in Figure 6. The structure 148 is preferably two ply and comprises an outer wall formed from part of the side wall panel 110. The outer wall comprises an access panel 150 and, optionally, a pair of outer panel portions 152, 154 disposed along opposing side edges of panel 150. Access panel 150 is hingedly connected to the portions 152, 154 along frangible lines 156 and 158 respectively and is hingedly connected to top panel 112 along fold line 120. The portion 152 is detachably connected to the outer side wall panel 110 along frangible line 163.

[0038] The inner wall of the access structure 148 is provided by inner panel 160 which is formed from a portion of inner side panel 118 and comprises a cut line 162 in spaced relationship with the free edge of panel 160, that is shaped to receive the leading edge of access panel 150 of the outer wall. There may further comprise a recess 166 shaped to receive a users finger to aid opening. Inner panel 160 is frangibly connected to inner side wall 118 along frangible line 164. There further comprises fastening means for securing the access flap structure to the carton to allow it to be closed again. In this embodiment, the fastening means is provided by a locking tab 168 which is defined by frangible line 164. The locking tab 168 is oriented in a direction away from the access flap structure 148.

[0039] The construction of the carton will now be described with reference to Figures 7, 8, 9 and 9a. First, a tubular structure is formed whereby outer side panel 110, and top panel 112 are folded about fold line 120 into a substantially perpendicular relationship. Similarly, second side wall panel 114 is folded out of alignment with top panel 112 and base panel 116 about fold lines 122 and 124 to be placed into a substantially perpendicular relationship with the aforementioned panels. Thereafter, inner side wall panel 118 is folded into a substantially perpendicular relationship with base panel 116 about fold line 126 whereby panels 110 and 118 are

placed in overlapping relationship and are secured together by suitable securing means, for example glue or other suitable means known in the art.

[0040] As regards the reclosable access flap structure, outer portions 152 and 154 are secured to inner panel 160 by glue or other suitable securing means known in the art. Articles P are then loaded at one or each end of the carton by hand or automatic machinery.

[0041] Thereafter, the end wall structures are formed whereby the gusset panel structures 136, 142; 136a, 142a are folded about fold lines 138, 124 and 144, 126 respectively thereby causing inner end panels 130, 130a to be folded about fold lines 134 and 134a respectively into substantially perpendicular relationship. As described above the triangular panels 137, 139 of the gusset wall structures are folded into face contacting relationship about fold line 146 and abut the respective side wall, or as the case may be the inner panel 160 of the access structure.

[0042] Outer end wall is folded about fold line 132 into overlapping relationship with inner end wall 130 and is secured together by glue or other suitable means known in the art. The carton is in a loaded full erected condition as shown in Figure 7.

[0043] In order to gain access to the articles contained in the carton, the reclosable access flap structure 148 is opened by a user of the carton. In order to open the carton, the user first tears the access panel 150 by pulling it outwardly and upwardly to separate it from outer portions 152 and 154 along frangible lines 156 and 158 respectively to reveal inner panel 160, as shown in Figure 8. Thereafter inner panel 160 is pulled in an outward and downward direction indicated by arrow X, which causes its side edge to be separated from side wall panel 118 along frangible line 164 and for outer portion 152 to be separated from outer side wall panel 110 along frangible line 163. The frangible line 164 is shaped to define a recess 167 for receiving a corresponding locking tab 168 formed as an extension of inner panel 160, shown in Figure 9.

[0044] In those embodiments with a gusset panel structure, the gusset panels 142a assist in maintaining the inner panel 160 of the access flap structure 148 in the position shown in Figure 9. Thus, a user has access to the articles P to be removed individually or as a group. It is envisaged that the length of the reclosable flap could be altered to allow only one item to be removed at a time, without departing from the scope of invention. In order to achieve this, frangible lines 163 and 164 would be moved along panels 110 and 118 respectively to increase or decrease the size of the opening, shown in Figure 9.

[0045] In order to reclose the carton, reference is made to Figure 9a in which the inner access panel 160 is folded inwardly in direction Y which causes the gusset panel 137 to be folded inwardly and into abutment with the other gusset panel 139 and inner panel 160. Locking tab 168 comes into abutment with outer side wall panel

110 and the inward folding action causes tab 168 to be deformed and pushed inwardly beyond the free edge of panel 110 to be received by the corresponding recess 167 and engaged thereto. Thereafter, outer panel 150 is folded downwards and the leading edge 169 (Figure 9A) is inserted through cut line 162 to secure the two panels together. It is envisaged that other suitable means could be employed to detachably connect the outer panel to the inner panel in the access flap structure, for example glue to provide an airtight carton with a reclosable access flap.

[0046] A third embodiment of fastening means is illustrated by reference to Figures 10a, 10b and 10c wherein like panels are designated by the same reference numeral for the second embodiment and are not therefore described in any greater detail.

[0047] The third embodiment discloses a dual locking tab arrangement whereby the frangible line 163 separating outer side panel 110 from outer access flap 150 is shaped to define a fastening means which in this embodiment is an outer locking tab 180 and a corresponding recess 182. Preferably, the outer locking tab 180 is offset from an inner locking tab 186 shown in Figure 10c. Inner locking tab 186 is similar to locking tab 168 described in the second embodiment and shall not therefore be described in any more detail.

[0048] Figure 10a illustrates the access flap structure in its closed state when the carton is in its fully erected and sealed condition. Figure 10b shows the first stage in opening the access structure, whereby the outer access panel 150 is detached from its adjacent outer portions 152 and 154 and folded in an upward and outward direction.

[0049] The next stage is for inner panel 160 of the access flap to be folded outwardly in direction X whereby the locking tabs 180 and 186 are detached from their respective side panels 110 and 118 and moved out of alignment with panel 160 to be placed in the position shown in Figure 10c. It will be seen in Figures 10B and 10C that there comprises recesses 182 and 184 defined by forming locking tabs 180 and 186 respectively and locking tab 180 which protrudes into recess 182 to engage part of the inner side wall panel 118 and, thereby, prevent the panel 160 from being pushed inwardly beyond panel 118. Thus the access flap structure can be maintained in a substantially coplanar relationship with the adjacent side wall. In order to reclose the access flap the inner panel 160 is first folded upwards and inward direction in a similar manner as described above such that inner locking tab 186 is caused to be pushed underneath outer side wall panel 110 to be engaged with recess 184. Thereafter outer panel 150 is secured to inner panel 160 as described above to reseal the carton.

[0050] Figures 11, 12 and 13 illustrate a fourth embodiment of the invention which is substantially the same as the second embodiment and therefore like reference numerals are used with the addition of reference numeral "2". The carton is constructed in a similar man-

ner to the second embodiment although, in this example, there is no gusset panel structure for forming the end panels and the side panel 218 forms the outer side wall with the inner side wall being provided by panel 210.

5 Thus it will be seen that inner and outer panels 250, 260 of the access flap structure have been reversed. Again, outer portions 252 and 254 are secured to panel 260 but in this embodiment to the inner face by glue or other suitable means known in the art.

10 **[0051]** In order to open the access flap structure, outer panel 260 is folded in an upward and outward direction Z which causes it to be detached from the rest of the carton along frangible line 264. This action also causes inner panel 250 to become detached from its adjacent
15 outer portions 252, 254 along the frangible lines, such that it is free to be folded in a downward and outward direction Y as shown in Figure 13. In this embodiment, the locking tab 268 is formed from an extension of outer portion 252 and is capable of being folded out of alignment therefrom during opening and closure of the access flap by interference with the panels forming the side wall, thereby to cause outer panel 260 to be engaged with the side wall. In this embodiment, inner panel 250 is secured to panel 260 by suitable securing means.
20 It is envisaged that the inner panel 250 could be secured to the outer face of panel 260 during reclosing, without departing from the scope of invention.

[0052] Beneficially the fourth embodiment results in the tearing action taking place in one go during the opening of the outer panel 260, rather than two separate tearing actions as in the case of the first embodiment.

[0053] The fifth embodiment of the invention is illustrated in Figures 14, 15 and 16 which shows a carton formed from the blank 308 made from paperboard or similar foldable sheet material for holding one or more articles. The construction of the blank 308 is illustrated by reference to Figure 14 in which there comprises an inner side wall panel 310, an end wall panel 312, an opposing side wall panel 314, opposing end wall panel 316 and an outer side wall panel 318 hingedly connected together in series along fold line 320, 322, 324 and 326 respectively. There further comprises a panel structure for forming the top and base which is substantially identical and therefore reference is made to the panels forming the top only.
35

[0054] There comprises first top wall panel 328, glue flap 330, second top wall flap 332, glue flap 334 and an outer top wall flap 336 configured in adjacent positions one to next and hingedly connected to the panels forming the sides and ends along fold line 338. In this embodiment, panels 328, 332 and 336 are sized to overlap thereby to provide a sealed top wall.

[0055] There may further comprise an inner support panel 340 extending from inner side panel 310 which is used to provide a two ply structure for part of the side wall. Glue flap 342 may be hingedly connected to panel 340 along fold line 346.

[0056] An access flap structure 380, shown in Figure

15, is formed from the top wall and upper parts of the side and end walls. The access flap structure 380 is defined in part by frangible line 348 which extends across side and end panels 310, 312 and a corresponding frangible line 356 extending across side wall 318 and end wall 316. There further comprises fold line 354 extending across panel 314: its ends intersecting with frangible lines 348 and 356 respectively. Thus when the carton is formed, frangible lines 348, 356 and fold line 354 form an endless fold line.

[0057] There may further comprise fastening means which in this embodiment is provided by a locking tab 358 and recess for allowing the access flap structure to be reclosed. In this embodiment, locking tab 358 is hingedly connected to side wall panel 318 along fold line 360 and is separated therefrom by a cut line 362 which defines the edge of the recess. Optionally, there further comprises a second locking tab 350 hingedly connected to side panel 310. In this embodiment, locking tab 350 is offset from the first locking tab 358 to provide a fastening means and that allows the upper and lower parts of the side and end walls to be reengaged by relative sliding movement.

[0058] In order to construct the carton, it is formed by first folding panels 310, 312, 314, 316, 318 about fold lines 320, 322, 324 and 326 to form a tubular structure whereby inner and outer side wall panel 310 and 318 overlap, at least in part, and are secured together by suitable securing means, for example glue or other suitable means known in the art. Optionally, support panel 340 and glue flap 342 are secured to the inner face of outer side panel 318 and end panel 316 respectively. Articles are then loaded through the top or base of the carton by relative movement.

[0059] Thereafter the top and base are formed whereby the outer panels 328, 336 are folded about fold line 338 into overlapping relationship with inner wall panel 332 and are secured thereto along glue flaps 330 and 334 respectively. Thus the carton is in an erected and loaded condition shown in Figure 15.

[0060] In order to open the access flap structure, locking tab 358 is gripped by the user and lifted in an upward direction whereby upper and lower parts of the carton are separated along frangible lines 348 and 356 to be folded about fold line 354, as shown in Figure 16.

[0061] In order to reclose the access flap, the locking tabs 350 and 358 of the fastening means are caused to slidably engage the corresponding recesses 361 and 363 respectively whereby a pocket 364 is defined to receive portion 350 to be engaged by the side panels 310, 318 by relative sliding movement between the aforesaid panels.

[0062] Beneficially the embodiments of the invention hereinbefore described provided a structure that is sufficiently strong to retain articles and to provide an integral sleeve or enclosed carton. The use of paperboard material provides an environmentally alternative to cartons made from plastic material and the sleeves made

from paperboard can include printed matter for marketing purposes.

[0063] It will be recognised that as used herein, the terms "top", "bottom" and "side" with respect to the panels of the carton (or carton blank) are relative terms, and that the carton (formed from the blank) may be re-oriented as necessary or as desired. It will be further recognised that rather than the bottom wall being formed from the interlocked panels, the carton blank may be re-arranged whereby some other wall such as a top wall or a side wall is formed from the interlocked panels.

[0064] The invention and its preferred embodiment relate to a carton or a sleeve which is shaped to provide satisfactory rigidity to hold items such as information discs for example floppy or zip discs or foodstuff with a degree of flexibility. The shape of the blank minimises the amount of paperboard required for the carton. The carton can be constructed from a flap cut at collapsed condition to position of use and/or loaded by hand or automatic machinery. It is anticipated the invention can be modified without departing from the scope of the invention: for example, side and end panels can be increased in height or width to provide a carton to receive one or more articles of different shapes and/or sizes. Additionally, the access flap and fastening structure shown in the various embodiments can be applied to other known carton types, for example a fully enclosed carton or wraparound cartons for beverage containers or for foodstuffs, without departing from the scope of invention.

Claims

1. A sleeve (70) for holding information discs or the like, the sleeve comprises a front panel (30), a reclosable cover flap (42, 46) for closing an open end of the sleeve, and fastening means (76) for fastening said cover flap (42, 46) to said front panel (30) after said cover flap (42, 46) is once opened, **characterised in that** said fastening means (76) being detachably connected to the cover flap (42, 46) and secured to said front panel (30), said fastening means (76) when detached being engageable with said cover flap (42, 46) by relative sliding movement between said cover flap (42, 46) and said front panel.
2. A sleeve (70) according to claim 1 wherein said fastening means (76) comprises a double layer securing panel (62, 64) secured to the front panel (30) and when detached said double layer securing panel (54, 56, 58, 60) defines between an outer layer (54, 58) thereof and said front panel (30) a pocket (78) for receiving a complementary portion (80) of said cover flap (42).
3. A sleeve (70) according to claim 2 wherein the pock-

et (78) is formed between a protruding portion (62) of the outer layer (54, 58) of said double layer securing panel (54, 56, 58, 60) and said front panel (30).

4. A sleeve (70) according to claim 2 wherein at least a portion of the cover flap (42, 46) is two ply such that said complementary portion (80) comprises a protruding portion of an inner layer (46) of said cover flap (42, 46) so as to provide a fully flat front face (26, 74) of the sleeve (70).
5. A sleeve (70) according to claim 4 wherein said fastening means (76) is connected to said cover flap (42, 46) by detachably connecting means which comprises a first frangible line (61, 63) connecting the inner layer (46) of said two ply portion of the cover flap (42, 46) to an inner layer (56, 60) of said double layer securing panel (54, 56, 58, 60) and a second frangible line (50, 52) connecting an outer layer (42) of said two ply portion of the cover flap (42, 46) to the outer layer (54, 58) of said double layer securing panel (54, 56, 58, 60), said first frangible line (61, 63) being offset outwardly from said second frangible (50, 52) line to define said pocket (78) and said complementary portion (80).
6. A blank (10) for forming a sleeve (70) for holding information discs or the like, comprising a back panel (12), opposed side (14, 22) and end (18, 26) panels hingedly connected to said back panel (12), a front panel (30) hingedly connected to one (26) of said end panels, a cover flap (42, 46) hingedly connected to the opposing one (18) of said end panels **characterised in that** said cover flap (42, 46) is capable of relative slidable movement with said front panel (30), and fastening means (54, 58, 56, 60) constructed and arranged to define a pocket (62) for receiving a free edge (80) of the cover flap (42, 46) when the sleeve (70) is set up.
7. A blank (10) according to claim 6 wherein the fastening means (54, 58, 56, 60) comprises a pair of securing panels (54, 56: 58, 60) detachably connected to said cover flap (42, 46) by detachably connecting means (50, 51: 52, 63) and hingedly connected to each other to be capable of forming a double layer panel (54, 56: 58, 60) adapted to be secured to the front panel (30).
8. A blank (10) according to claim 6 or claim 7 wherein the cover flap (42, 46) comprises inner (46) and outer (42) layers hingedly connected together along a common end edge (48).
9. A carton for holding one or more articles (P), comprising a reclosable access flap (46, 42; 160,152; 260,252;380) to close parts of a double ply carton

wall (76; 118, 110; 218, 210; 318, 310), said access flap (46, 42; 160,152; 260,252;380) being detachably connected at one of its ends to the said double ply carton wall, **characterised in that** there further comprises fastening means (80; 168; 186; 268; 350) for cooperating with a panel (54; 110; 218; 318) of said double ply carton wall to retain said access flap in a closed position after said access flap is detached from said double ply carton wall.

10. The carton as claimed in claim 9 wherein said access flap (46, 42; 160,152; 260,252;380) is a double ply structure and the inner (46; 160,252) and outer (42; 152,260) layers of the access flap are connected to inner (56; 118; 210; 310) and outer (54; 110; 218; 318) layers of the double ply carton wall along first (61; 164; 348) and second (50; 168; 356) frangible lines wherein at least a portion of the first (156, 356) frangible line (61; 164; 348) is offset from the second frangible line (50; 168; 356) so that when the access flap (46, 42; 160,152; 260,252; 380) is detached from the carton wall along the first (61; 164; 348) and second (50; 168; 356) frangible lines, the offset portion of the first frangible line defines said fastening means (80; 168; 186; 268; 350).
11. The carton as claimed in claim 10 wherein said fastening means comprises a first locking tab (186, 350) defined by said portion of said first frangible line (348) and a second locking tab (180, 358) defined by at least a portion of the second frangible line (356).
12. The carton according to claim 10 wherein the inner (46; 160; 252) and outer (42; 152; 260) layers of the access flap are frangibly connected respectively to the inner (56; 118; 210; 310) and outer (54; 110; 218; 318) layers of said carton wall to be severed therefrom when the access flap (46, 42; 160,152; 252,260;380) is detached from the double ply carton wall.
13. A blank (10, 108, 308) for forming a carton for holding one or more articles **characterised in that** the blank comprises a top wall panel (18; 112; 310, 318), a base wall panel (26, 116, 314), opposed side panels (12,30; 110, 114, 118; 312, 316,) hingedly connected together in series and end wall panels (14, 22; 128, 130; 328,330, 332, 334, 336), **characterised in that** there further comprises an access flap (42, 46; 150, 160; 380) hingedly connected to said top (18; 112; 310, 318) or base (25, 116, 314) wall panel and fastening means so constructed and arranged to define a pocket (78, 167, 364) for receiving part (80, 168, 350) of the access flap when the carton is set up.
14. A blank (10, 108; 308) according to claim 14 where-

in the fastening means comprises a locking tab panel (80, 168, 350) frangibly connected by frangible connection means (61, 164, 348) to the adjacent wall (56, 118, 310).

15. A blank (10, 108; 308) according to claim 14 wherein the access flap (42, 46; 150, 160; 380) comprises inner (46, 160) and outer (42, 150) panels hingedly connected to at least one of the base (25, 116, 314) and top (18; 112; 310, 318) wall panels respectively along an end edge (44; 126, 120).
16. A blank (10, 108; 308) for forming a carton as claimed in any of claims 9 to 13.

Patentansprüche

1. Hülle (70) zum Aufbewahren von Informationsscheiben oder dergleichen, wobei die Hülle eine Vorderwandfläche (30), eine wiederverschließbare Abdeckklappe (42, 46) zum Verschließen eines offenen Endes der Hülle sowie Befestigungsmittel (76) umfasst, um die Abdeckklappe (42, 46) an die Vorderwandfläche (30) zu befestigen, nachdem die Abdeckklappe (42, 46) einmal geöffnet worden ist, **dadurch gekennzeichnet, dass** die Befestigungsmittel (76) abnehmbar mit der Abdeckklappe (42, 46) verbunden sind und an die Vorderwandfläche (30) befestigt sind, wobei die Befestigungsmittel (76), wenn diese abgenommen sind, von der Abdeckklappe (42, 46) durch eine relative Gleitbewegung zwischen der Abdeckklappe (42, 46) und der Vorderwandfläche in Eingriff genommen werden können.
2. Hülle (70) nach Anspruch 1, wobei die Befestigungsmittel (76) eine zweischichtige Befestigungswandfläche (62, 64) umfassen, die an die Vorderwandfläche (30) befestigt ist, und wobei die zweischichtige Befestigungswandfläche (54, 56, 58, 60), wenn diese abgenommen ist, zwischen einer äußeren Schicht (54, 58) von dieser und der Vorderwandfläche (30) eine Tasche (78) definiert, um einen komplementären Abschnitt (80) der Abdeckklappe (42) aufzunehmen.
3. Hülle (70) nach Anspruch 2, wobei die Tasche (78) zwischen einem vorstehenden Abschnitt (62) der äußeren Schicht (54, 58) der zweischichtigen Befestigungswandfläche (54, 56, 58, 60) und der Vorderwandfläche (30) ausgebildet ist.
4. Hülle (70) nach Anspruch 2, wobei wenigstens ein Abschnitt der Abdeckklappe (42, 46) zweilagig ist, so dass der komplementäre Abschnitt (80) einen abstehenden Abschnitt einer inneren Schicht (46) der Abdeckklappe (42, 46) umfasst, um eine voll-
- ständig flache Vorderseite (26, 74) der Hülle (70) bereitzustellen.
5. Hülle (70) nach Anspruch 4, wobei die Befestigungsmittel (76) mit der Abdeckklappe (42, 46) durch abnehmbare Verbindungsmittel verbunden sind, die eine erste Brechlinie (61, 63) umfassen, die die innere Schicht (46) des zweilagigen Abschnitts der Abdeckklappe (42, 46) mit einer inneren Schicht (56, 60) der zweischichtigen Befestigungswandfläche (54, 56, 58, 60) verbindet, sowie eine zweite Brechlinie (50, 52), die eine äußere Schicht (42) des zweilagigen Abschnitts der Abdeckklappe (42, 46) mit der äußeren Schicht (54, 58) der zweischichtigen Befestigungswandfläche (54, 56, 58, 60) verbindet, wobei die erste Brechlinie (61, 63) von der zweiten Brechlinie (50, 52) nach außen versetzt ist, um die Tasche (78) und den komplementären Abschnitt (80) zu definieren.
6. Zuschnitt (10) zum Ausbilden einer Hülle (70) zum Aufbewahren von Informationsscheiben oder dergleichen, umfassend eine Rückwandfläche (12), gegenüberliegende Seiten- (14, 22) und Endwandflächen (18, 26), die gelenkig mit der Rückwandfläche (12) verbunden sind, eine Vorderwandfläche (30), die gelenkig mit einer (26) der Endwandflächen verbunden ist, eine Abdeckwandfläche (42, 46), die gelenkig mit der gegenüberliegenden Endwandfläche (18) verbunden ist, **dadurch gekennzeichnet, dass** die Abdeckklappe (42, 46) für eine relative gleitbare Bewegung mit der Vorderwandfläche (30) geeignet ist, wobei die Befestigungsmittel (54, 56, 58, 60) ausgestaltet und angeordnet sind, eine Tasche (62) zu definieren, um eine freie Kante (80) der Abdeckklappe (42, 46) aufzunehmen, wenn die Hülle (70) aufgerichtet wird.
7. Zuschnitt (10) nach Anspruch 6, wobei die Befestigungsmittel (54, 58, 56, 60) ein Paar von Befestigungswandflächen (54, 56, 58, 60) umfassen, die abnehmbar mit der Abdeckklappe (42, 46) durch abnehmbare Verbindungsmittel (50, 51, 52, 63) verbunden sind und gelenkig miteinander verbunden sind, um dazu in der Lage zu sein, eine zweischichtige Wandfläche (54, 56, 58, 60) auszubilden, die angepasst ist, an der Vorderwandfläche (30) befestigt zu werden.
8. Zuschnitt (10) nach Anspruch 6 oder 7, wobei die Abdeckklappe (42, 46) innere (46) und äußere (42) Schichten umfasst, die gelenkig entlang einer gemeinsamen Endkante (48) gelenkig miteinander verbunden sind.
9. Schachtel zum Halten eines oder mehrerer Gegenstände (P), wobei die Schachtel eine wiederverschließbare Zugangsklappe (46, 42; 160, 152; 260,

252; 380) umfasst, um Teile einer zweilagigen Schachtelwand (76; 118, 110; 218, 210; 318, 310) zu schließen, wobei die Zugangsklappe (46, 42; 160, 152; 260, 252; 380) an einem ihrer Enden abnehmbar mit der zweilagigen Sachachtelwand verbunden ist, **dadurch gekennzeichnet, dass** ferner Befestigungsmittel (80; 168; 186; 268; 350) umfasst werden, um mit einer Wandfläche (54; 110; 218; 318) der zweilagigen Schachtelwand zusammenzuwirken, um die Zugangsklappe in einer geschlossenen Position zurückzuhalten, nachdem die Zugangsklappe von der zweilagigen Schachtelwand abgenommen worden ist.

10. Schachtel nach Anspruch 9, wobei die Zugangsklappe (46, 42; 160, 152; 260, 252; 380) eine zweilagige Struktur ist und die innere (46; 160, 252) und die äußere (42; 152, 260) Schicht der Zugangsklappe mit inneren (56; 118; 210; 310) und äußeren (54; 110; 218; 318) Schichten der zweilagigen Schachtelwand entlang erster (61; 164; 348) und zweiter (50; 168; 356) Brechlinien verbunden ist, wobei wenigstens ein Abschnitt der ersten (156, 356) Brechlinie (61; 164; 348) von der zweiten Brechlinie (50; 168; 356) versetzt ist, so dass dann, wenn die Zugangsklappe (46, 42; 160, 152; 260, 252; 380) von der Schachtelwand entlang der ersten (61; 164; 348) und der zweiten (50; 168; 356) Brechlinie abgenommen wird, der versetzte Abschnitt der ersten Brechlinie die Befestigungsmittel (80; 168; 186; 268; 350) definiert.

11. Schachtel nach Anspruch 10, wobei die Befestigungsmittel eine erste Verriegelungslasche (186, 350) umfassen, die durch den Abschnitt der ersten Brechlinie (348) definiert ist, sowie eine zweite Verriegelungslasche (180, 358), die von wenigstens einem Teil der zweiten Brechlinie (356) definiert ist.

12. Schachtel nach Anspruch 10, wobei die innere (46; 160; 252) und die äußere (42; 152; 260) Schicht der Zugangsklappe jeweils zerbrechlich mit der inneren (56; 118; 210; 310) und der äußeren (54; 110; 218; 318) Schicht der Schachtelwand verbunden sind, um von dieser getrennt zu werden, wenn die Zugangsklappe (46, 42; 160, 152; 252, 260; 380) von der zweilagigen Schachtelwand abgenommen wird.

13. Zuschnitt (10, 108, 308) zum Ausbilden einer Schachtel zum Aufbewahren eines oder mehrerer Gegenstände, **dadurch gekennzeichnet, dass** der Zuschnitt eine Deckenwandfläche (18; 112; 310, 318) umfasst, eine Bodenwandfläche (26, 116, 314), gegenüberliegende Seitenwandflächen (12, 30; 110, 114, 118; 312, 316), die der Reihe nach gelenkig miteinander verbunden sind, sowie Endwandflächen (14, 22; 128, 130; 328, 330, 332, 334,

336), **dadurch gekennzeichnet, dass** ferner eine Zugangsklappe (42, 46; 150, 160; 380) umfasst wird, die gelenkig mit der Deckenwandfläche (18; 112; 310, 318) oder der Bodenwandfläche (25, 116, 314) verbunden ist, sowie Befestigungsmittel, die derart ausgestaltet und angeordnet sind, dass sie eine Tasche (78, 167, 364) definieren, um einen Teil (80, 168, 350) der Zugangsklappe aufzunehmen, wenn die Schachtel aufgerichtet wird.

14. Zuschnitt (10, 108; 308) nach Anspruch 14, wobei die Befestigungsmittel eine Verriegelungslaschenwandfläche (80, 168, 350) umfassen, die mittels Brechverbindungsmiteln (61, 164, 348) mit der angrenzenden Wand (56, 118, 310) zerbrechlich verbunden sind.

15. Zuschnitt (10, 108; 308) nach Anspruch 14, wobei die Zugangsklappe (42, 46; 150, 160; 380) innere (46, 160) und äußere (42, 150) Wandflächen umfasst, die jeweils entlang einer Endkante (44; 126, 120) mit wenigstens der Bodenwandfläche (25, 116, 314) bzw. der Deckenwandfläche (18; 112; 310, 318) verbunden sind.

16. Zuschnitt (10, 108; 308) zum Ausbilden einer Schachtel nach einem der Ansprüche 9 bis 13.

30 Revendications

1. Pochette (70) destinée à contenir des disques d'information ou objets similaires, la pochette comprend un panneau avant (30), un rabat de couvercle refermable (42, 46) pour fermer une extrémité ouverte de la pochette, et un moyen de fixation (76) pour fixer ledit rabat de couvercle (42, 46) sur ledit panneau avant (30) après que ledit rabat de couvercle (42, 46) a été ouvert une fois, **caractérisée en ce que** ledit moyen de fixation (76) est connecté de manière détachable au rabat de couvercle (42, 46) et attaché audit panneau avant (30), ledit moyen de fixation (76), lorsqu'il est détaché, pouvant être mis en prise avec ledit rabat de couvercle (42, 46) par un mouvement e glissement relatif entre ledit rabat de couvercle (42, 46) et ledit panneau avant.

2. Pochette (70) selon la revendication 1, dans laquelle ledit moyen de fixation (76) comprend un panneau de fixation à double couche (62, 64) attaché au panneau avant (30) et, lorsqu'il est détaché, ledit panneau de fixation à double couche (54, 56, 58, 60) définit entre une couche extérieure (54, 58) de celui-ci et ledit panneau avant (30) une poche (78) destinée à recevoir une partie complémentaire (80) dudit rabat de couvercle (42).

3. Pochette (70) selon la revendication 2, dans laquelle la poche (78) est formée entre une partie saillante (62) de la couche extérieure (54, 58) dudit panneau de fixation à double couche (54, 56, 58, 60) et ledit panneau avant (30). 5
4. Pochette (70) selon la revendication 2, dans laquelle au moins une partie du rabat de couvercle (42, 46) est à deux couches, de sorte que ladite partie complémentaire (80) comprend une partie saillante d'une couche intérieure (46) dudit rabat de couvercle (42, 46) afin de fournir une face avant complètement plate (26, 74) de la pochette (70). 10
5. Pochette (70) selon la revendication 4, dans laquelle ledit moyen de fixation (76) est connecté audit rabat de couvercle (42, 46), par un moyen de connexion détachable qui comprend une première ligne fragile (61, 63) reliant la couche intérieure (46) de ladite partie à deux couches du rabat de couvercle (42, 46) à une couche intérieure (56, 60) dudit panneau de fixation à double couche (54, 56, 58, 60) et une deuxième ligne fragile (50, 52) reliant une couche extérieure (42) de ladite partie à deux couches du rabat de couvercle (42, 46) à la couche extérieure (54, 58) dudit panneau de fixation à double couche (54, 56, 58, 60), ladite première ligne fragile (61, 63) étant décalée vers l'extérieur par rapport à ladite deuxième ligne fragile (50, 52) pour définir ladite poche (78) et ladite partie complémentaire (80). 15
20
25
30
6. Découpe (10) pour former une pochette (70) destinée à contenir des disques d'information ou objets similaires, comprenant un panneau arrière (12), des panneaux latéraux (14, 22) et d'extrémité (18, 26) opposés connectés de manière articulée audit panneau arrière (12), un panneau avant (30) connecté de manière articulée à l'un (26) desdits panneaux d'extrémité, un rabat de couvercle (42, 46) connecté de manière articulée au panneau opposé (18) desdits panneaux d'extrémité, **caractérisée en ce que** ledit rabat de couvercle (42, 46) est apte à suivre un mouvement glissant relatif avec ledit panneau avant (30), et un moyen de fixation (54, 58, 56, 60) conçu et agencé pour définir une poche (62) destinée à recevoir un bord libre (80) du rabat de couvercle (42, 46) lorsque la pochette (70) est assemblée. 35
40
45
7. Découpe (10) selon la revendication 6, dans laquelle le moyen de fixation (54, 58, 56, 60) comprend une paire de panneaux de fixation (54, 56 ; 58, 60) connectés de façon détachable audit rabat de couvercle (42, 46) par des moyens de connexion détachables (50, 51 ; 52, 63) et connectés de manière articulée entre eux pour être capables de former un panneau à double couche (54, 56 ; 58, 60) adapté pour être fixé au panneau avant (30). 50
55
8. Découpe (10) selon la revendication 6 ou 7, dans laquelle le rabat de couvercle (42, 46) comprend des couches intérieure (46) et extérieure (42) connectées de manière articulée l'une à l'autre le long d'un bord d'extrémité commun (48). 5
9. Carton destiné à contenir un ou plusieurs article(s) (P), comprenant un rabat d'accès refermable (46, 42 ; 160, 152 ; 260, 252 ; 380) pour fermer des parties d'une paroi (76 ; 118, 110 ; 218, 210 ; 318, 310) de carton à deux couches, ledit rabat d'accès (46, 42 ; 160, 152 ; 260, 252 ; 380) étant connecté de manière détachable en une de ses extrémités à ladite paroi de carton à deux couches, **caractérisé en ce qu'il** comprend en outre un moyen de fixation (80 ; 168 ; 186 ; 268 ; 350) destiné à coopérer avec un panneau (54 ; 110 ; 218 ; 318) de ladite paroi de carton à deux couches pour retenir ledit rabat d'accès dans une position fermée après que ledit rabat d'accès a été détaché de ladite paroi de carton à deux couches. 10
10. Carton selon la revendication 9, dans lequel ledit rabat d'accès (46, 42 ; 160, 152 ; 260, 252 ; 380) a une structure à deux couches et les couches intérieure (46 ; 160, 252) et extérieure (42 ; 152, 260) du rabat d'accès sont connectées aux couches intérieure (56 ; 118 ; 210 ; 310) et extérieure (54 ; 110 ; 218 ; 318) de la paroi de carton à deux couches le long d'une première (61 ; 164 ; 348) et d'une deuxième (50 ; 168 ; 356) lignes fragiles, où au moins une partie de la première (156, 356) ligne fragile (61 ; 164 ; 348) est décalée par rapport à la deuxième ligne fragile (50 ; 168 ; 356) de sorte que lorsque le rabat d'accès (46, 42 ; 160, 152 ; 260, 252 ; 380) est détaché de la paroi de carton le long de la première (61 ; 134 ; 348) et de la deuxième (50 ; 168 ; 356) lignes fragiles, la partie décalée de la première ligne fragile définit ledit moyen de fixation (80 ; 168 ; 186 ; 268 ; 350). 25
30
35
40
45
11. Carton selon la revendication 10, dans lequel ledit moyen de fixation comprend une première patte de blocage (186, 350) définie par ladite partie de ladite première ligne fragile (348) et une deuxième patte de blocage (180, 358) définie par au moins une partie de la deuxième ligne fragile (356). 50
12. Carton selon la revendication 10, dans lequel les couches intérieure (46 ; 160 ; 252) et extérieure (42 ; 152 ; 260) du rabat d'accès sont connectées de manière fragile respectivement aux couches intérieure (56 ; 118 ; 210 ; 310) et extérieure (54 ; 110 ; 218 ; 318) de ladite paroi de carton pour être séparées de celles-ci lorsque le rabat d'accès (46, 42 ; 160, 152 ; 252, 260 ; 380) est détaché de 1 paroi de carton à deux couches. 55

13. Découpe (10, 108, 308) pour former un carton destiné à contenir un ou plusieurs article(s), **caractérisée en ce que** la découpe comprend un panneau de paroi supérieure (18 ; 112 ; 310, 318), un panneau de paroi de base (26, 116, 314), des panneaux latéraux opposés (12, 30 ; 110, 114, 118 ; 312, 316) connectés de manière articulée ensemble en série et des panneaux de parois d'extrémités (14, 22 ; 128, 130 ; 328, 330, 332, 334, 336), **caractérisée en ce qu'elle** comprend en outre un rabat d'accès (42, 46 ; 150, 160 ; 380) connecté de manière articulée audit panneau de paroi supérieure (18 ; 112 ; 310, 318) ou de base (25, 116, 314) et un moyen de fixation conçu et agencé de façon à définir une poche (78, 167, 364) pour recevoir une partie (80, 168, 350) du rabat d'accès lorsque le carton est assemblé. 5 10 15
14. Découpe (10, 108 ; 308) selon la revendication 13, dans laquelle le moyen de fixation comprend un panneau de patte de blocage (80, 168, 350) connecté de manière fragile par un moyen de connexion fragile (61, 164, 348) à la paroi adjacente (56, 118, 310). 20 25
15. Découpe (10, 108 ; 308) selon la revendication 14, dans laquelle le rabat d'accès (42, 46 ; 150, 160 ; 380) comprend des panneaux intérieur (46, 160) et extérieur (42, 150) connectés de manière articulée à au moins l'un des panneaux de paroi de base (25, 116, 314) et supérieure (18 ; 112 ; 310, 318) respectivement le long d'un bord d'extrémité (44 ; 126, 120). 30
16. Découpe (10, 108 ; 308) pour former un carton conforme à l'une quelconque des revendications 9 à 13. 35

40

45

50

55

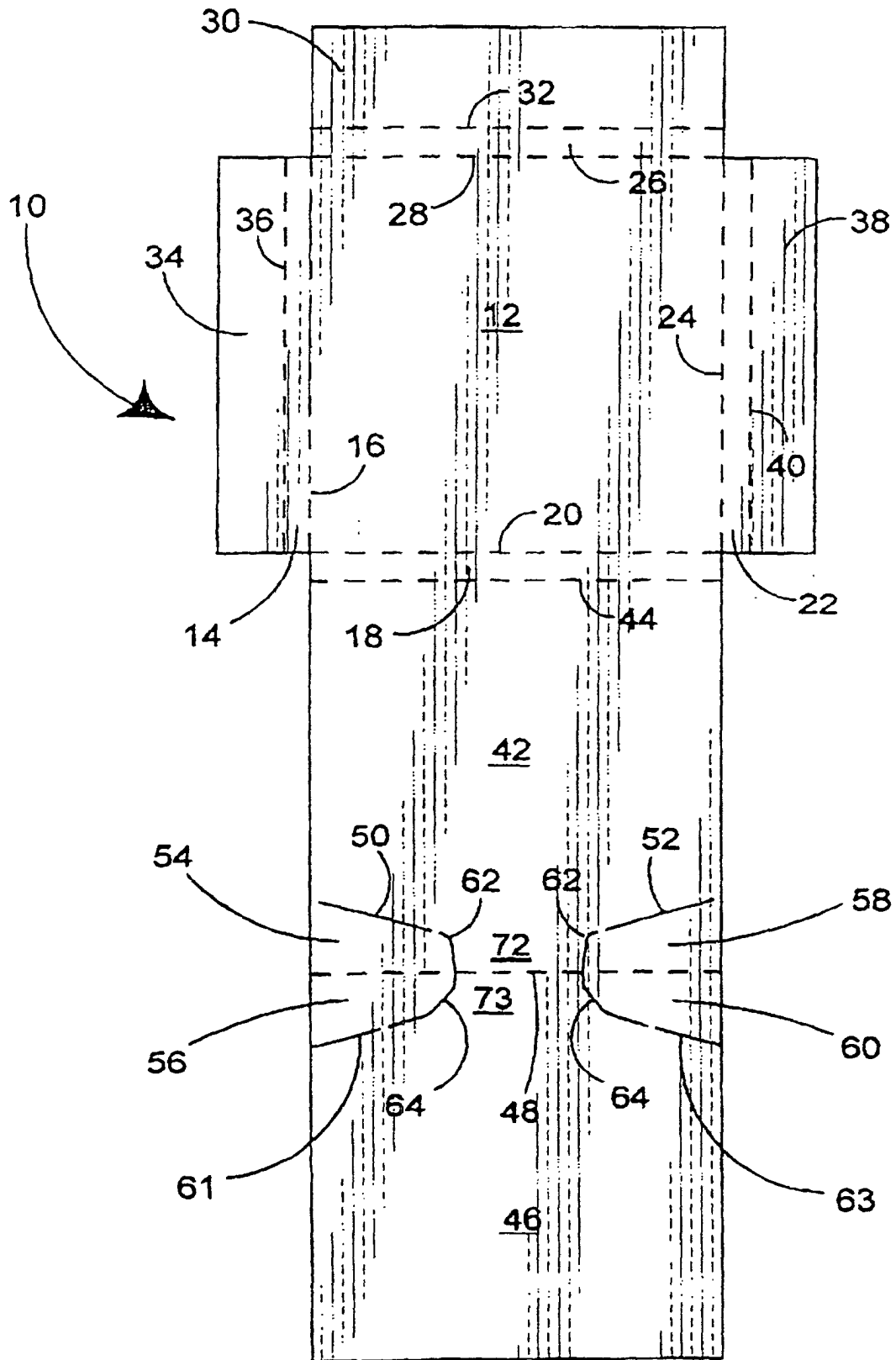

FIGURE 1

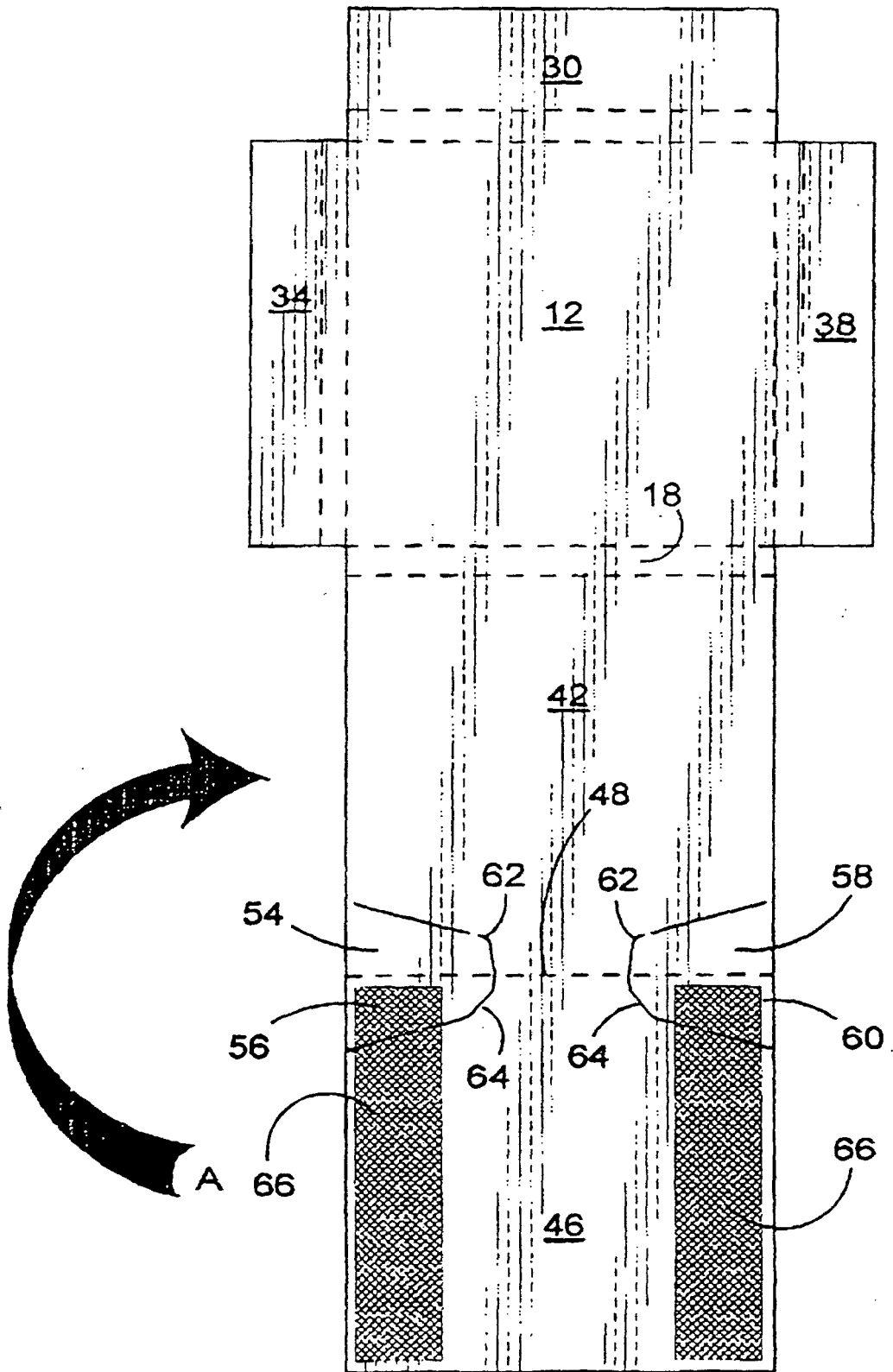

FIGURE 2

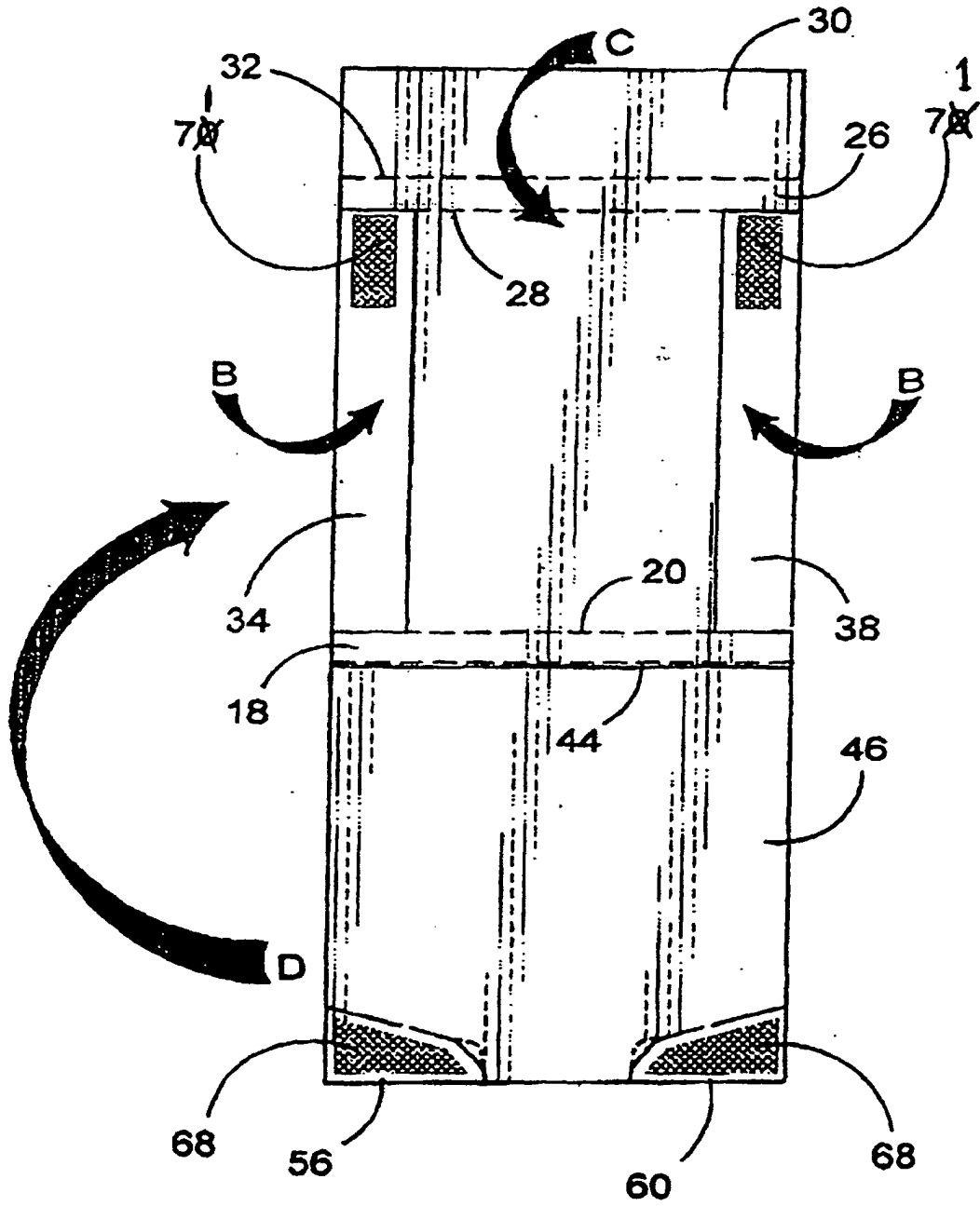
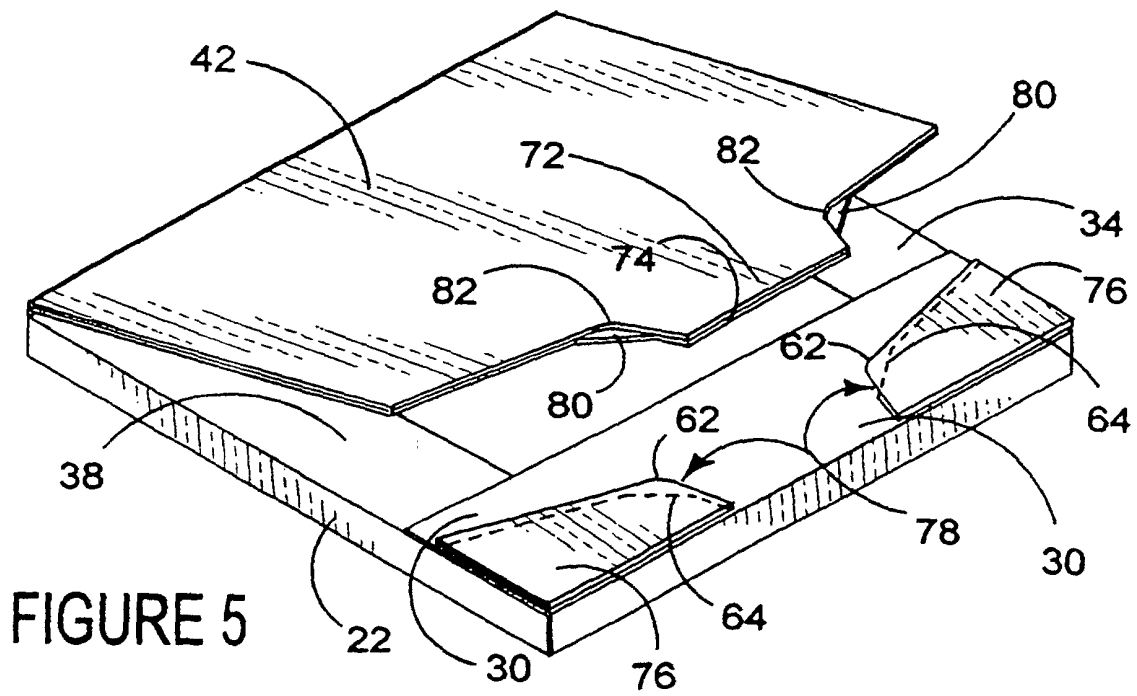
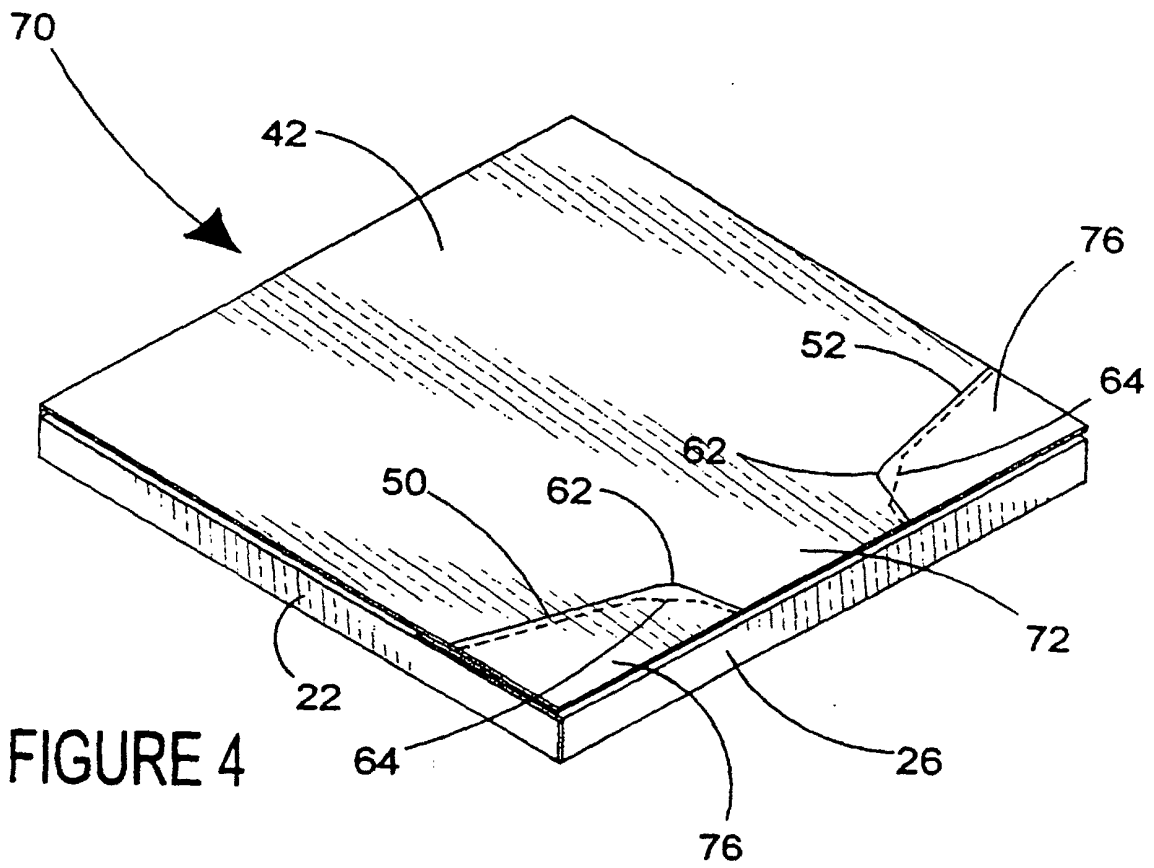

FIGURE 3



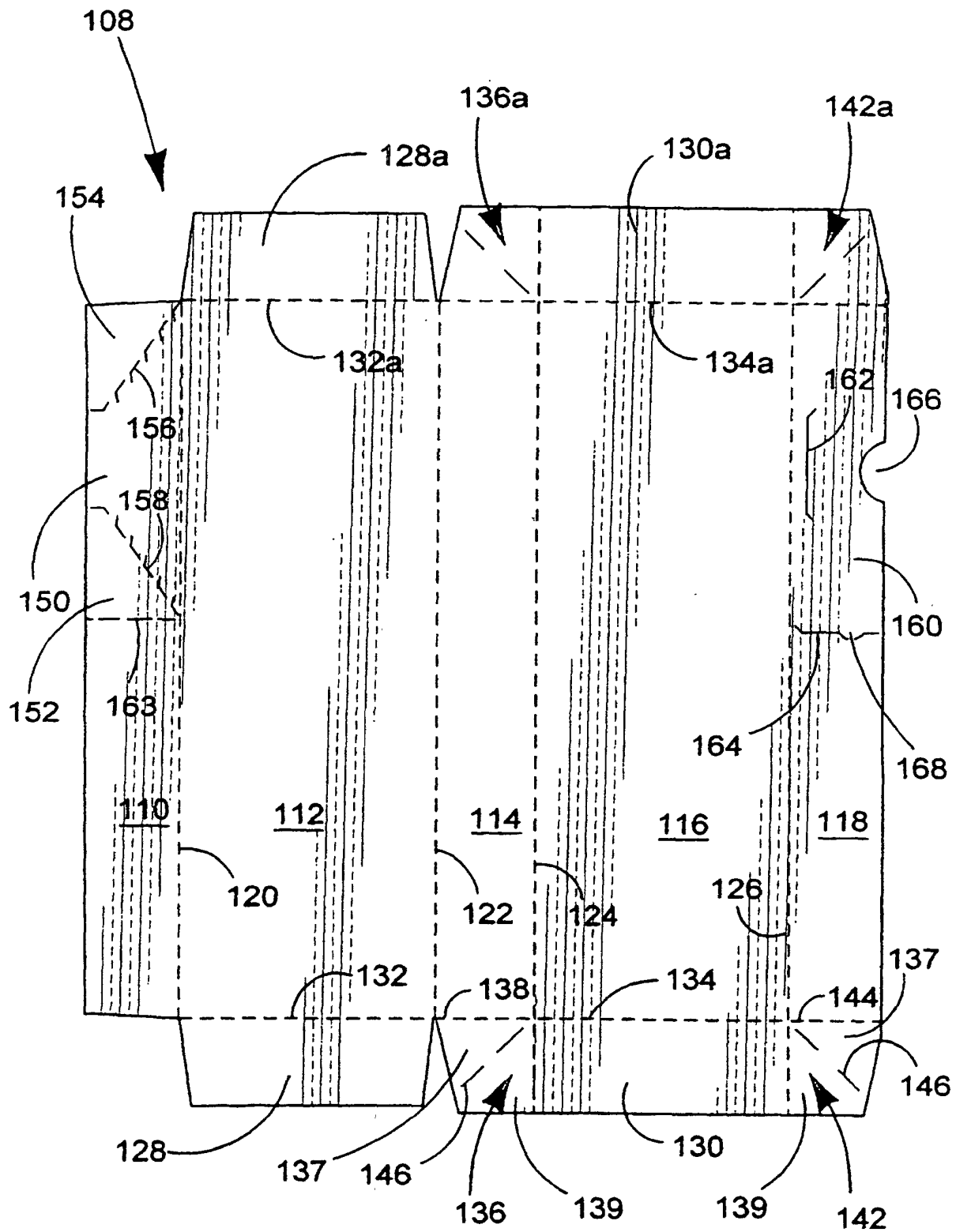
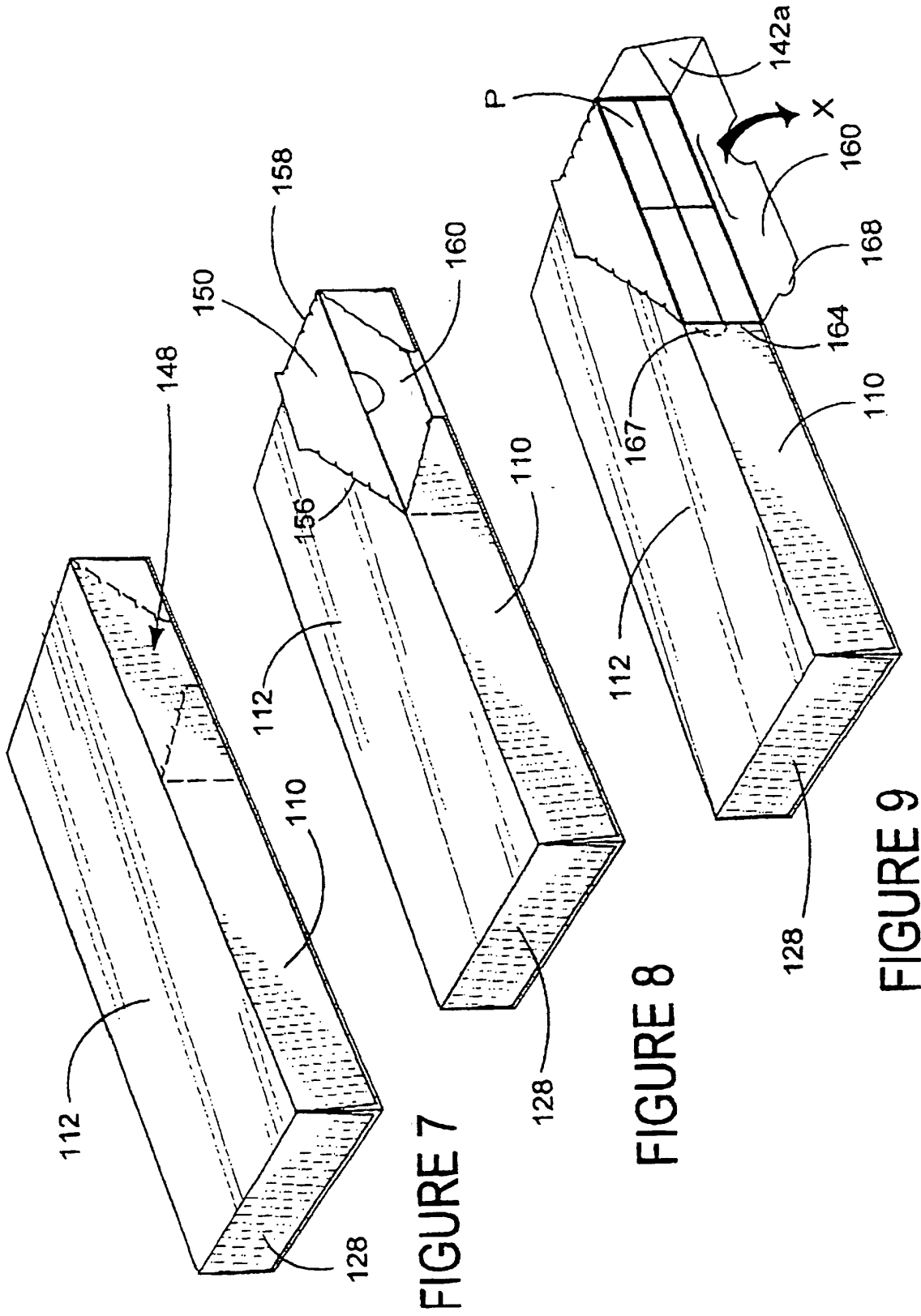

FIGURE 6



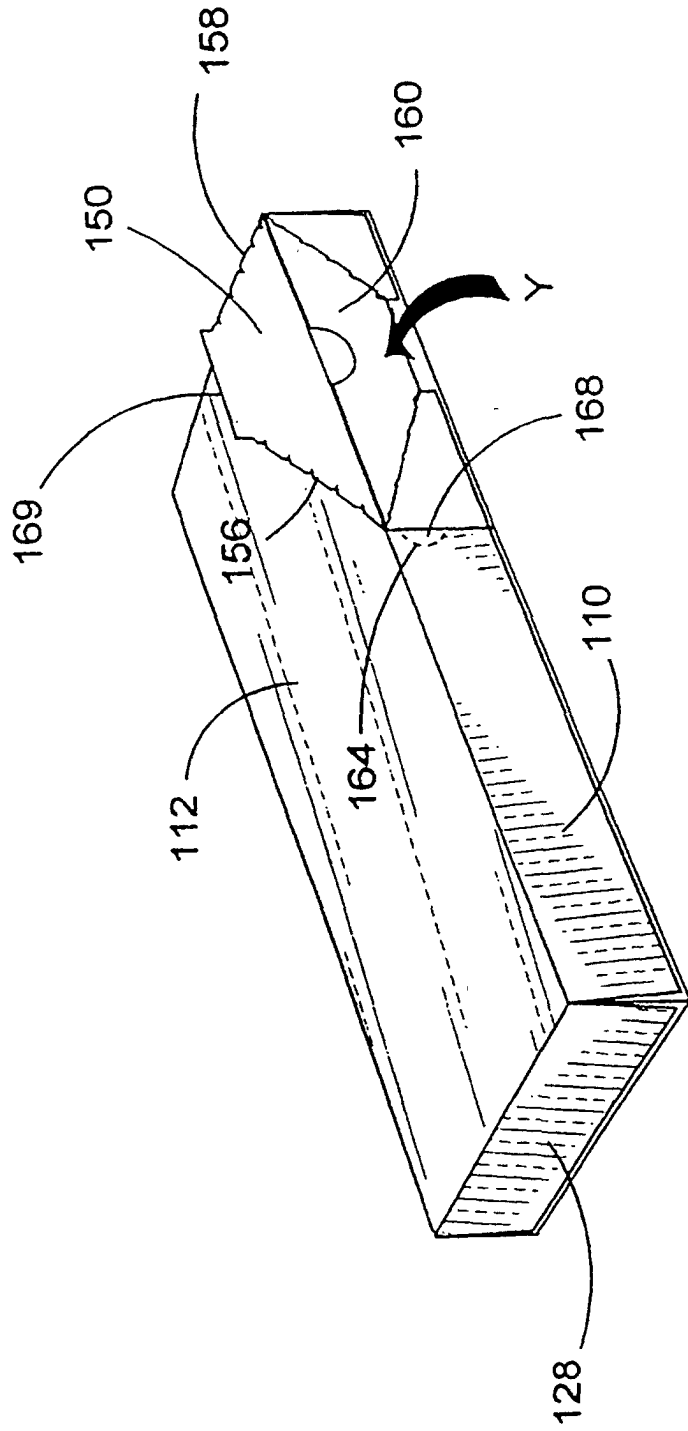
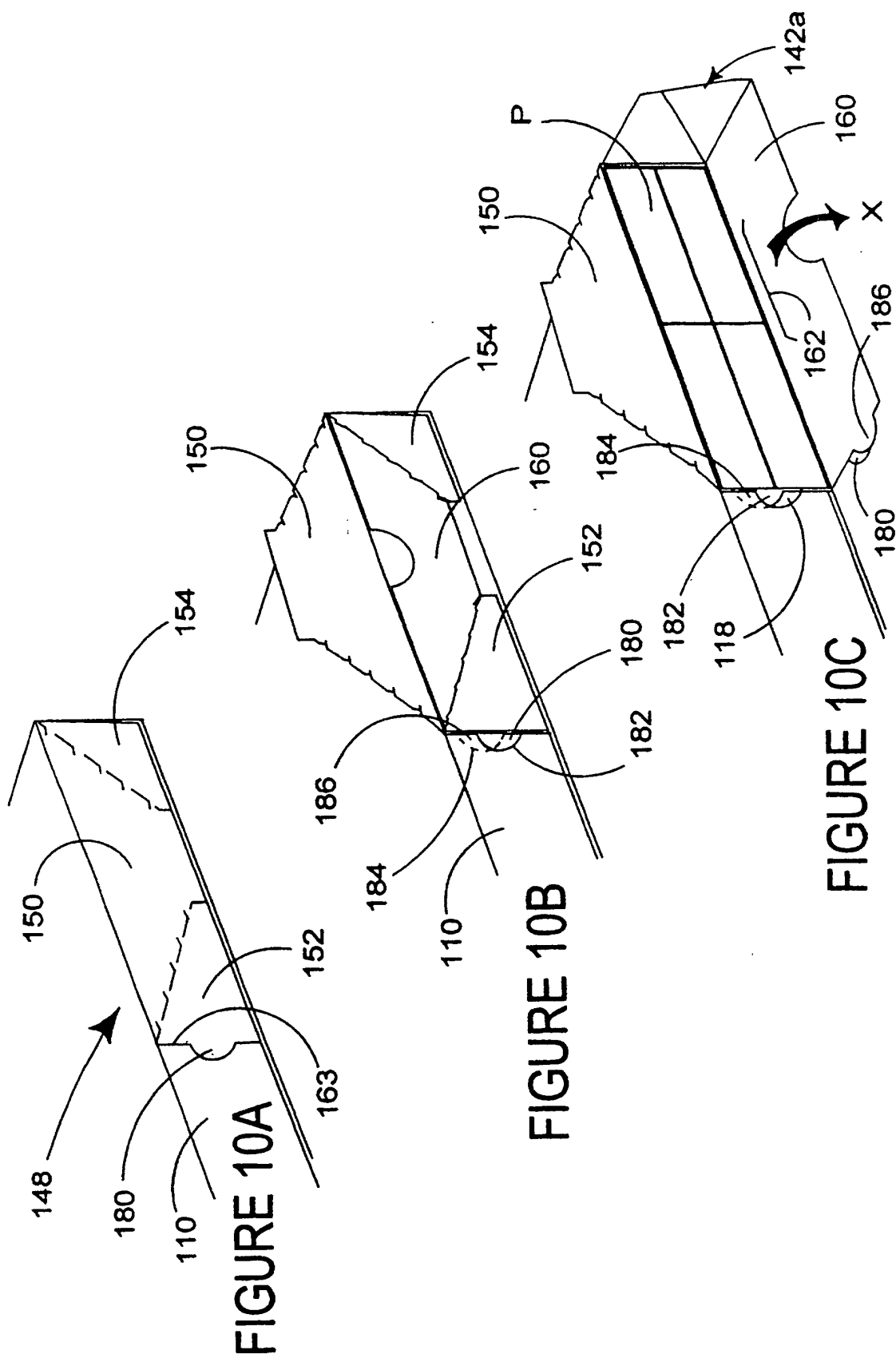
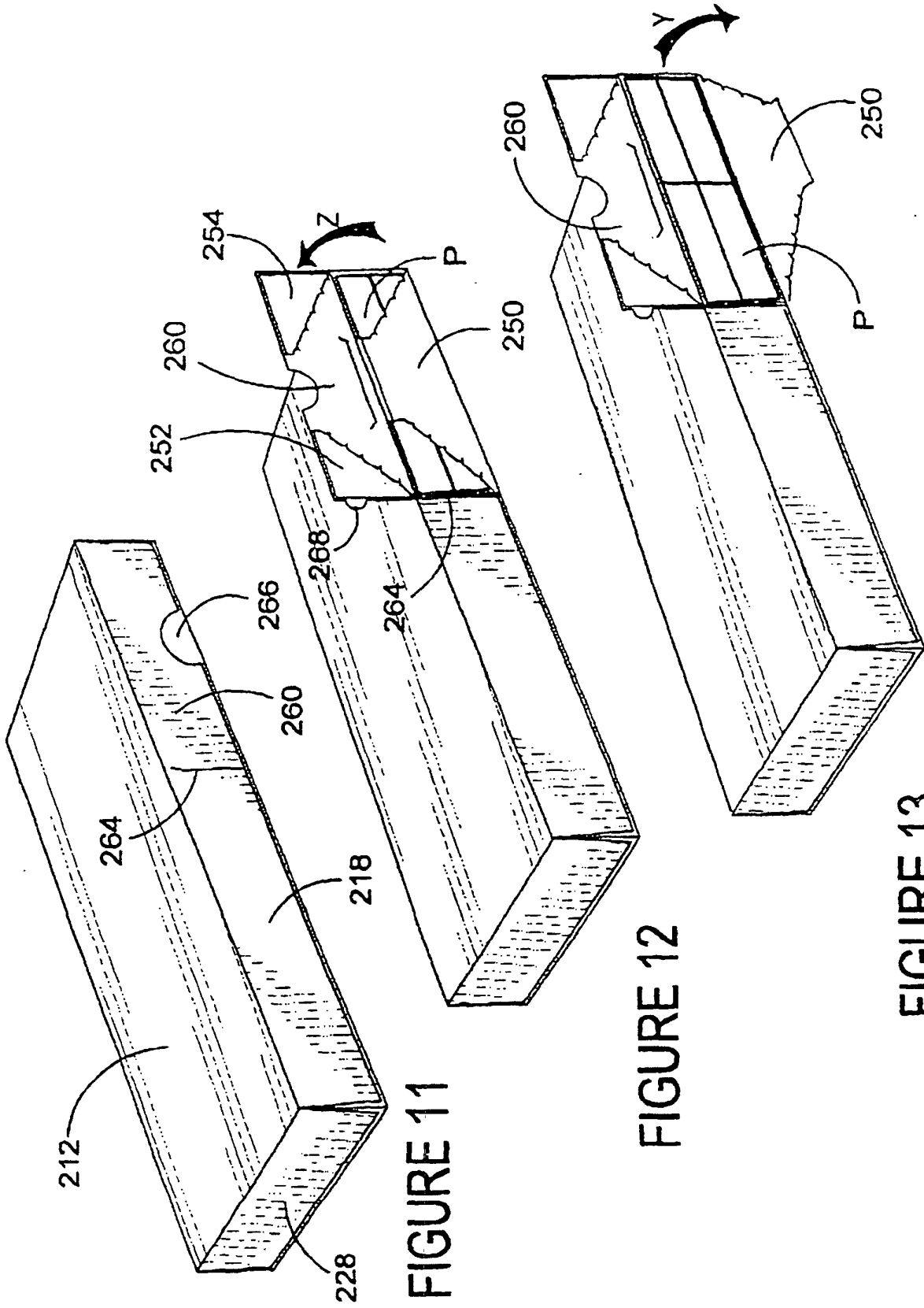

FIGURE 9A





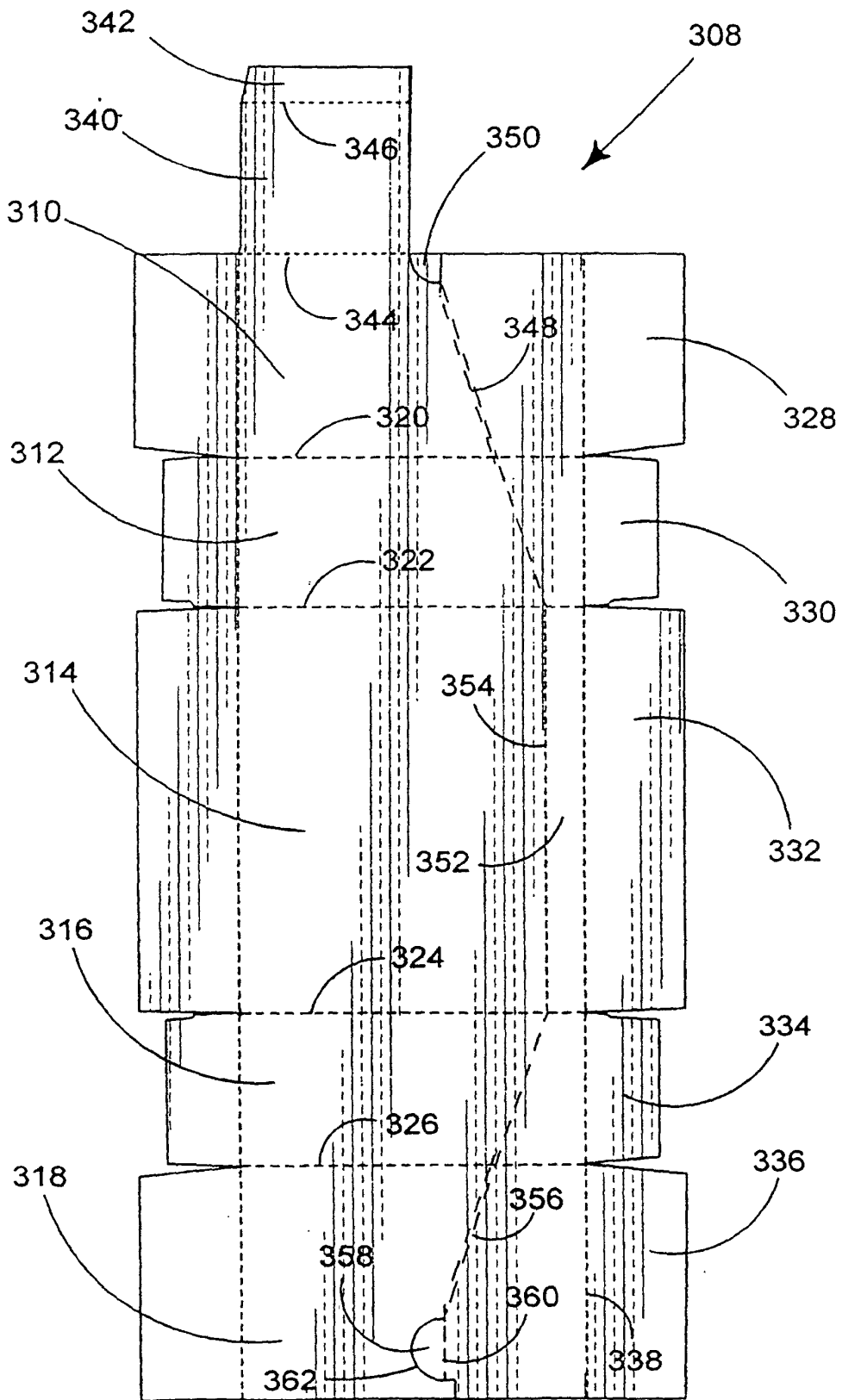

FIGURE 14

