

Feb. 12, 1952

J. J. PALOTSEE

2,585,402

BLADE FOR HONES

Original Filed Nov. 12, 1946

3 Sheets-Sheet 1

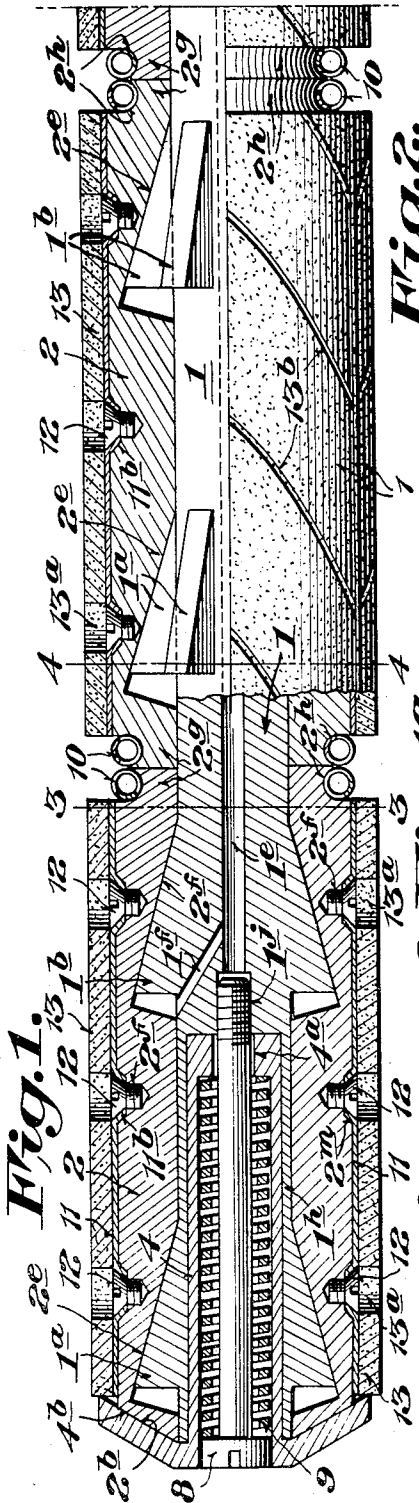

Fig. 2.

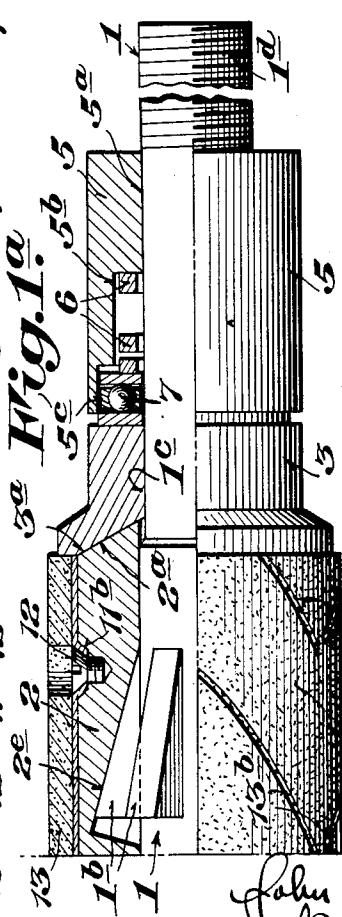
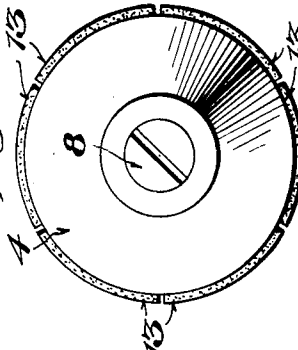

Fig. 1a.

Fig. 16. Fig. 17.

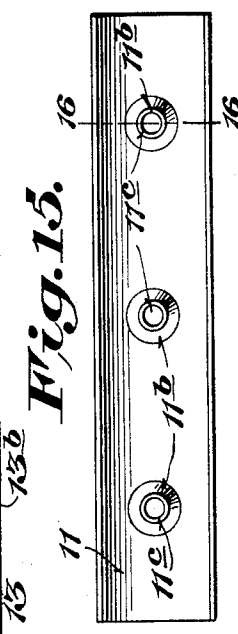
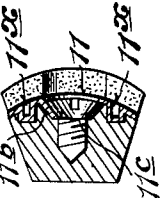

Fig. 15.

334

Inventor
John J. Palotsee
Charles H. Russell

Attorneys

Feb. 12, 1952

J. J. PALOTSEE

2,585,402

BLADE FOR HONES

Original Filed Nov. 12, 1946

3 Sheets-Sheet 2

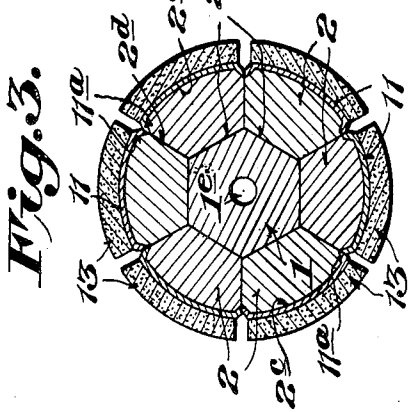
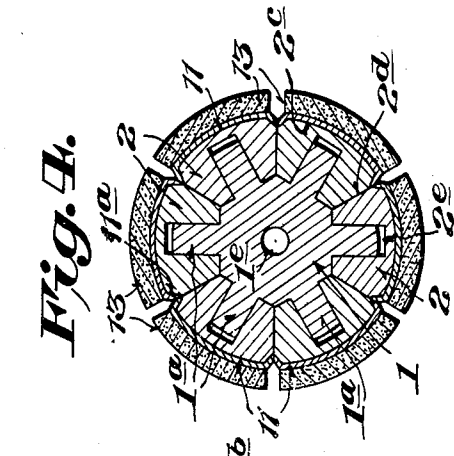
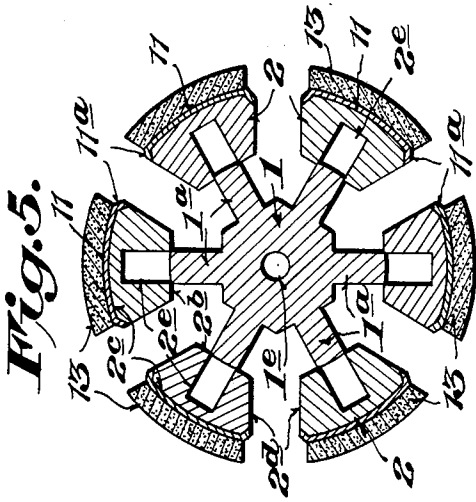

Fig. 8.



Fig. 9.



334

Inventor
 John F. Palotsee
 Alexander Howell
 Attorneys

Feb. 12, 1952

J. J. PALOTSEE

2,585,402

BLADE FOR HONES

Original Filed Nov. 12, 1946

3 Sheets-Sheet 3

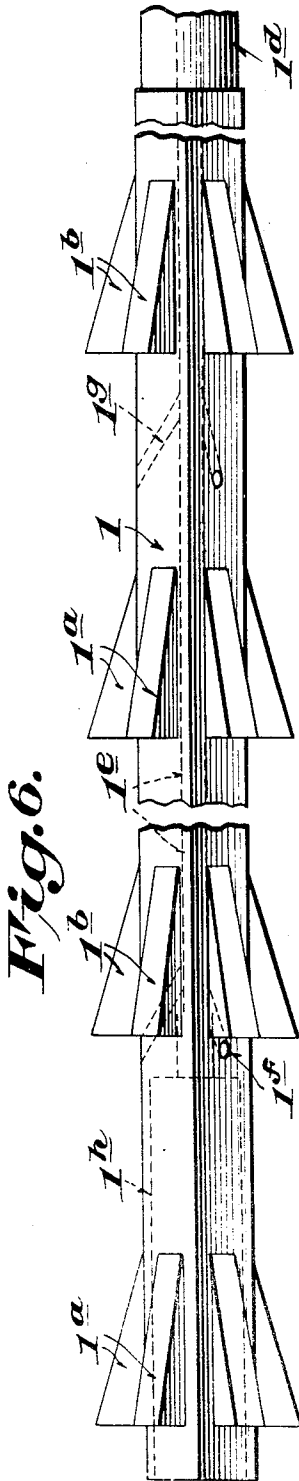

Fig. 6.



Fig. 7.



Fig. 10.

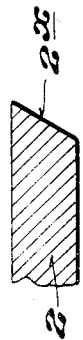

Fig. 11.

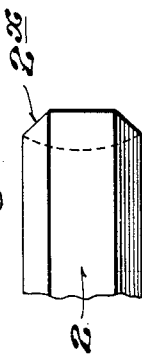

Fig. 12.



Fig. 13.

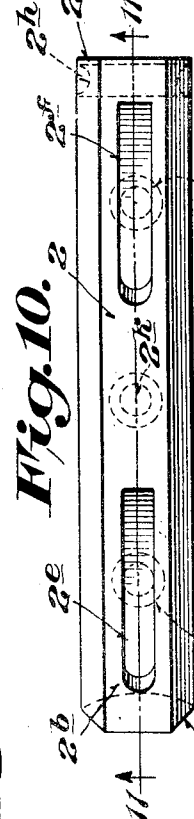

Fig. 14.

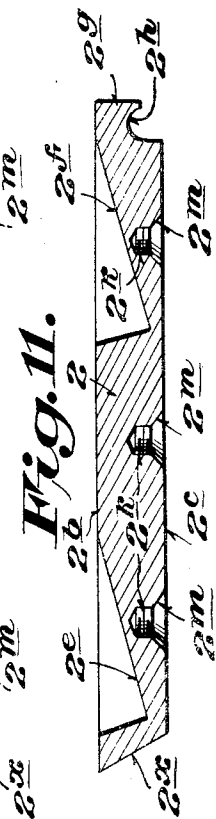

Fig. 15.

334

Inventor
 John J. Palotsee
 [Signature]

Attorney

UNITED STATES PATENT OFFICE

2,585,402

BLADE FOR HONES

John J. Palotsee, Youngstown, Ohio

Original application November 12, 1946, Serial No. 709,177, now Patent No. 2,443,268, dated June 15, 1948. Divided and this application February 27, 1948, Serial No. 11,380

7 Claims. (Cl. 51—204)

1

2

This invention is a novel adjustable hone particularly adapted for use in connection with hone driving or rotating machines, preferably but not necessarily of the type shown in my U. S. Letters Patent No. 2,358,247 dated September 12, 1944, the present invention being an improvement on the hone disclosed in my U. S. Letters Patent No. 2,269,378 dated January 6, 1942; No. 2,332,463 dated October 19, 1943; No. 2,338,963 dated January 11, 1944 and the hone disclosed in my copending application Serial No. 585,629, filed March 30, 1945, which issued as Patent No. 2,412,419, dated December 10, 1946.

The present application is a division of my copending application Serial No. 709,177, filed November 12, 1946, now U. S. Letters Patent No. 2,443,268, dated June 15, 1948.

The principal objects of the present invention are to provide an adjustable abrasive cylindrical hone, particularly adapted for grinding, machine finishing, polishing or boring cylindrical bearings or the like, the hone consisting of a spindle carrying an annular series of radially disposed blades, each carrying a Carborundum or other abrasive stone section, the stones of the blades when fully contracted around the spindle forming a cylindrical surface having spiral grooves on the exterior surface thereof, the blades and spindle being provided with complementary tapered surfaces, with means for simultaneously shifting the blades axially of the spindle to effect expansion or contraction of the hone with respect to the spindle to vary the diameter thereof, and the spindle having means thereon for yieldably maintaining the blades in close contact therewith in all adjusted diameters, while permitting shifting of the blades with respect to the spindle.

A further object of the invention is to provide a hone of the above type with an improved novel means for assembling and mounting the Carborundum stones on their related blades, whereby various different sets or types of Carborundum or other abrasive stones may be used with the same set of blades, to perform different kinds or grades of work.

A further object of the invention is to provide an adjustable hone comprising a plurality of sets of aligned blades on one spindle with means whereby the hones may be contracted and expanded simultaneously by a single adjusting means.

Further minor objects of the invention will be hereinafter set forth.

I will explain the invention with reference to the accompanying drawings, which illustrate several practical embodiments thereof, to enable others familiar with the art to adopt and use the same; and will summarize in the claims the novel features of construction, and novel combinations of parts, for which protection is desired.

In said drawings:

Figures 1 and 1a together show a longitudinal section, partly in elevation, through a hone embodying my invention.

Fig. 2 is an outer end view of the hone shown in Fig. 1.

Fig. 3 is a section on the line 3—3, Fig. 1.

Fig. 4 is a section on the line 4—4, Fig. 1, showing the blades in fully retracted position.

Fig. 5 is a section similar to Fig. 4, showing the blades in fully expanded position.

Fig. 6 is a plan view of the spindle, detached.

Fig. 7 is an end view of the spindle, shown in Fig. 6.

Fig. 8 is an elevation of the spring holder shown in Fig. 1, detached.

Fig. 9 is an elevation showing the spring and bolt used in connection with the holder shown in Fig. 8, detached.

Fig. 10 is a bottom plan view of one of the stone holding blades, detached.

Fig. 11 is a longitudinal section, on the line 11—11, Fig. 10.

Fig. 12 is an end view of the blade shown in Fig. 10.

Fig. 13 is a bottom plan view showing the end of a modified blade.

Fig. 14 is a longitudinal section through the end of the blade shown in Fig. 13.

Fig. 15 is a plan view of one of the stone holders.

Fig. 16 is a section on the line 16—16, Fig. 15.

Fig. 17 is similar to Fig. 15 but showing a section through a modified stone holder.

The hone comprises a spindle 1 of hexagonal cross section and of relatively great length, having thereon spaced pairs of inclined cam surfaces 1a, 1b (Fig. 6) preferably formed integrally therewith, said surfaces 1a, 1b sloping in the same direction and at the same angle with respect to the spindle 1, the surfaces 1a, 1b being each disposed at the center of one of the faces of the spindle 1. In Figs. 4 and 5, the spindle 1 is shown hexagonal in cross-section, hence each annular series of cam surfaces 1a, 1b would comprise six in number; however, if the spindle has 4, 8 or more sides, a corresponding number of surfaces 1a, 1b in each series would be provided. Each annular series of inclined surfaces 1a, 1b is adapted to support an annular series of blades, which carry the stones, there being as many annular series of blades as there are sets of cam surfaces 1a, 1b.

One end of spindle 1 is reduced as at 1c (Fig. 1a) and the adjacent end of the spindle 1 is threaded as at 1d, said threaded portion 1d being adapted to be mounted directly on the shaft of a honing machine, such as disclosed in my U. S. Letters Patent No. 2,358,247 dated September 12, 1944, although the same may be mounted in any other type of driving or rotating machine. Preferably spindle 1 is provided with a bore 1e extending therethrough, from the threaded end

1d to a point adjacent the other end, at which point lateral ducts 1f extend from the bore 1e to the exterior of the spindle and just beyond the larger end of the inclined surfaces 1b of the outer series. Also, lateral ducts 1g (Fig. 6) extend from bore 1e and discharge between each of the remaining sets of cam surfaces 1a, 1b, the duct 1e being adapted to supply lubricant from the honing machine which is discharged into the spindle beneath each set of stones 2, to lubricate the parts and to assist in the honing operation.

Slidably mounted upon the reduced portion 1c of the spindle 1, adjacent the threaded portion 1d, is a collar 3 (Fig. 1a) having a conical face 3a engaging the correspondingly beveled ends 2a of the innermost set of blades 2, the conical face 3a maintaining the adjacent ends of the blades 2 in assembled relation around the spindle.

Around the spindle 1 and contacting the inner end of the collar 3 is an anti-friction bearing 7; and on the threaded end 1d of spindle 1 is an adjusting collar or nut 5 which may be of smooth bore, as at 5a, or to engage the threads 1d of the spindle 1. Nut 5 is provided with an annular recess 5b in its end adjacent the collar 3, said recess housing a spring 6. The recess 5b is enlarged at its outer end 5c adjacent the collar 3 to receive the end of anti-friction bearing 7. The collar or nut 5 may be shifted by any desired means or manually rotated to shift the collar 3 axially of spindle 1, the means for rotating the nut forming no part of my present invention.

At the outer end of the spindle 1 is a cylindrical bore 1h extending to the outer end of the spindle 1, said bore receiving a tubular spring holder 4 (Fig. 8) having its inner end closed but provided with a hole 4a (Figs. 1 and 8) for the passage of a bolt 3 (Figs. 1 and 9), the head of which slidably fits the bore of the spring holder 4, said bolt 3 having its inner end threaded to engage a tapped enlargement 1j of the lubricant bore 1e of the spindle 1, the bolt 3 closing the bore 1e beyond the lateral duct 1f. Within the spring holder 4, interposed between the inner end thereof and the head of bolt 3 is a spring 9 (Figs. 1 and 9) normally urging the spring holder 4 inwardly of the bore 1h into the position shown in Fig. 1, the spring however, permitting the spring holder 4 to slide outwardly of bore 1h for the purpose hereinafter described. The outer end of sleeve 4 beyond the adjacent end of the spindle 1 is provided with a conically shaped head 4b similar to but oppositely inclined with respect to the conical recess 3a of collar 3, said conical head 4b of the spring holder engaging the adjacent tapered ends 2b of the outermost set of blades 2, as shown in Fig. 1.

By the above construction, when collar or nut 5 is shifted on the spindle 1 towards the collar 3, the collar 3 will be shifted towards the head 4b, and the blades 2 will be thereby shifted radially outwardly or inwardly on the cam surfaces 1a, 1b; the conical portions 3a and 4b of collar 3 and spring holder 4, respectively, holding the blades 2 in assembled relation around the spindle, while permitting enlarging and contracting of the effective diameter of the hone.

Spring 6 in collar or nut 5 is somewhat stiffer than spring 9 in spring holder 4, so that as collar or nut 5 is shifted toward the head 4b, the pressure of the stronger spring 6 acting through the collar 3 will shift the blades 2 against the action of the weaker spring 9, this yieldably permitting the conical head 4b to be shifted a corresponding amount.

As shown in Figs. 10, 11 and 12, each blade 2 is substantially frusto-triangular in cross-section, same having a base 2b of substantially the same width as its related face of the polygonal spindle 1, and having its outer face 2c arcuate in shape, the sides 2d being radially cut so that when the blades 2 are fully contracted around the spindle 1, as shown in Figs. 3 and 4, the sides 2d will squarely abut while the outer surfaces 2c will form a substantially cylindrical surface entirely around the spindle 1 concentric with the axis thereof.

In the base 2b of each blade are a pair of spaced inclined slots 2e; 2f respectively, the bases of which are inclined at the same angle to the axis of the spindle 1 as the inclined cam surfaces 1a, 1b of the spindle. The slots 2e slidably engage the cam surfaces 1a of the spindle while the slots 2f engage the inclined cam surfaces 1b of the related set on the spindle 1, as indicated in Figs. 1 and 1a, so that, as the assembly of blades 2 is shifted axially of the spindle, the effective diameter of the hone will be increased or decreased according to the direction of movement of the blades. Preferably the bases of the slots 2e, 2f are flat, while the outer faces of the inclined surfaces 1a, 1b may be arcuate, the latter giving the hone smoother operation. However, the outer ends of the inclined cam surfaces 1a, 1b may if desired be also flat.

The inner end of the outermost set of blades 2 opposite from the inclined end 2x has an extension 2g, as shown in Figs. 1, 10 and 11, the outer face of which has a semi-circular groove 2h for the reception of an endless coiled spring 10 seating in the groove 2h, the spring 10 contracting the adjacent ends of the series of blades 2 around the spindle 1, while permitting expansion and contraction of the effective diameter of the hone. Both ends of the intermediate blades 2 would be similarly provided with extensions 2g with grooves 2h for the reception of similar endless springs 10. The inner ends of the innermost series of blades 2 adjacent the collar 3 would be similarly constructed to receive an endless spring 10 for contracting the ends of that set of blades around the spindle 1.

In event the hone spindle 1 is relatively short, and holds only one set of blades 2, instead of the multiple sets shown, the extensions 2g of the blades shown in Figs. 10 and 11 would be omitted and both ends of the blades would be beveled as at 2x (Figs. 13 and 14), the bevel corresponding with the conical portions 2b and 2a respectively of the blades shown in Figs. 1, 10, and 11.

In the outer face of each blade 2 are a series of tapped bores 2k (Fig. 11) having their outer ends countersunk as at 2m whereby the stone holders 11 shown more particularly in Figs. 15, 16 and 17 may be secured to the blades 2.

Each stone holder 11, shown in Figs. 15 and 16, comprises a metallic strip of arcuate shape conforming with the curvature of the outer face 2c of the respective blades 2, the side edges of the holder 11 being flanged divergently downwardly as at 11a, if desired, to contact correspondingly shaped shortedge portions at the sides of their respective blades 2, as indicated in Figs. 3, 4 and 5. Holders 11 are also provided with conical offset portions 11b (Fig. 16) adapted to fill the countersunk portions 2m of the blades (Fig. 11), the offset portions 11b having holes 11c therethrough for the passage of the screws 12 which secure the holders 11 to the blades 2. A modified structure of the stone holder 11 is

5

6

shown in Fig. 17, in which reference numerals denote similar parts. However, the flanges 11a at the sides are omitted, and extending longitudinally of the holder 11 at each side of the offset portions 11c are troughs 11x to assist in retaining the stone 13 on the holder, the stones having openings 13a therein opposite each of the screws 12 which hold the holders on the blades 2. The stones 13 may be secured to the outer surfaces of holders 11 in any desired manner to form an integral unit therewith, preferably by means of cement or other adhesive.

By the above construction different sets of stones 13, mounted in their holders 11 may be used with the same set of blades 2, to provide a hone for performing different characters of work, the stones 13 with their holders 11 being readily removable or attachable to the blades 2 by inserting or removing the screws 12.

In operation

Movement of the blades 2 axially of the spindle 1 by shifting the nut 5 causes the blades 2 to move away from or towards the center of the spindle 1, thus increasing or decreasing the diameter of the hone. This movement is the result of a thrust against collar 5, the spring 6 in the collar or nut 5 acting against the anti-friction bearing 7. The shifting of collar 5 may be performed electrically, hydraulically, manually or by any other suitable means.

Spiral grooves 13b are cut in the stones 13 to facilitate cutting, said grooves permitting cuttings and cutting fluid to pass away. The direction of the spiral grooves is preferably reversed on adjacent stones to improve cutting.

The length of the hone will determine the number of sets of blades 2 and the diameter of the hone will determine the number of blades in each set. Instead of being formed conical, the head 4b and the recess 3a in collar 3, and the ends of the blades 2a, 2b may be formed as frustums of a pyramid.

I do not limit my invention to the exact forms shown in the drawings, for obviously changes may be made therein within the scope of the claims.

I claim:

1. In a hone, a blade having an arcuate outer face and having aligned countersunk tapped bores; countersunk screws engaging said bores; an arcuate holder plate on the outer face of the blade having open aligned conical offset portions on its under side receiving the countersunk heads of said screws passing through the offset portions, and honing stones adhesively secured to the holder plate and having access openings therethrough opposite the offset portions.

2. In a hone, a blade having an arcuate outer face and having aligned countersunk tapped bores; countersunk screws engaging said bores; an arcuate holder plate on the outer face of the blade having open aligned conical offset portions on its under side receiving the countersunk heads of said screws passing through the offset portions, and honing stones adhesively secured to the holder plate and having access openings therethrough opposite the offset portions, the side edges of the holder being flanged laterally and engaging correspondingly beveled portions at the sides of the blade.

3. In a hone, a blade having an arcuate outer face and having aligned countersunk tapped bores; countersunk screws engaging said bores; an arcuate holder plate on the outer face of the blade having open aligned conical offset portions

on its under side receiving the countersunk heads of said screws passing through the offset portions, and honing stones adhesively secured to the holder and having access openings therethrough opposite the offset portions, the holder plate having longitudinal troughs therein spaced from both sides of the conical offset portions receiving corresponding ribs on the under side of the stone.

4. In a hone, a blade having an arcuate outer face and having aligned countersunk tapped bores; countersunk screws engaging said bores; an arcuate holder plate on the outer face of the blade having open aligned conical offset portions on its under side receiving the countersunk heads of said screws passing through the offset portions, honing stones adhesively secured to the holder and having access openings therethrough opposite the offset portions, and arcuate extensions on the ends of the blade provided with semi-circular grooves.

5. In a hone, a blade having an arcuate outer face and having aligned countersunk tapped bores; countersunk screws engaging said bores; an arcuate holder plate on the outer face of the blade having open aligned conical offset portions on its under side receiving the countersunk heads of said screws passing through the offset portions, honing stones adhesively secured to the holder and having access openings therethrough opposite the offset portions; the side edges of the holder being flanged laterally and engaging correspondingly beveled portions at the sides of the blade; and arcuate extensions on the ends of the blade provided with semi-circular grooves.

6. In a hone, a blade having an arcuate outer face and having aligned countersunk tapped bores; countersunk screws engaging said bores; an arcuate holder plate on the outer face of the blade having open aligned conical offset portions on its under side receiving the countersunk heads of said screws passing through the offset portions, honing stones adhesively secured to the holder and having access openings therethrough opposite the offset portions; the holder having longitudinal troughs therein spaced from both sides of the conical offset portions receiving corresponding ribs on the under side of the stone; and arcuate extensions on the ends of the blade provided with semi-circular grooves.

7. In a hone, a blade having an arcuate outer face and having aligned countersunk tapped bores; countersunk screws engaging said bores; an arcuate holder plate on the outer face of the blade having open aligned conical offset portions on its under side receiving the countersunk heads of said screws passing through the offset portions, honing stones adhesively secured to the holder and having access openings therethrough opposite the offset portions; the holder having longitudinal troughs therein spaced from both sides of the conical offset portions receiving corresponding ribs on the under side of the stone; and arcuate extensions on the ends of the blades provided with semi-circular grooves.

JOHN J. PALOTSEE.

REFERENCES CITED

The following references are of record in the file of this patent:

UNITED STATES PATENTS

Number	Name	Date
1,821,518	Jeschke	Sept. 1, 1931
2,246,223	Shue	June 17, 1941
2,412,419	Palotsee	Dec. 10, 1946