

Feb. 24, 1953

E. LEADERMAN

2,629,240

YARN CHANGING MEANS FOR CIRCULAR KNITTING MACHINES

Filed Feb. 8, 1950

5 Sheets-Sheet 2

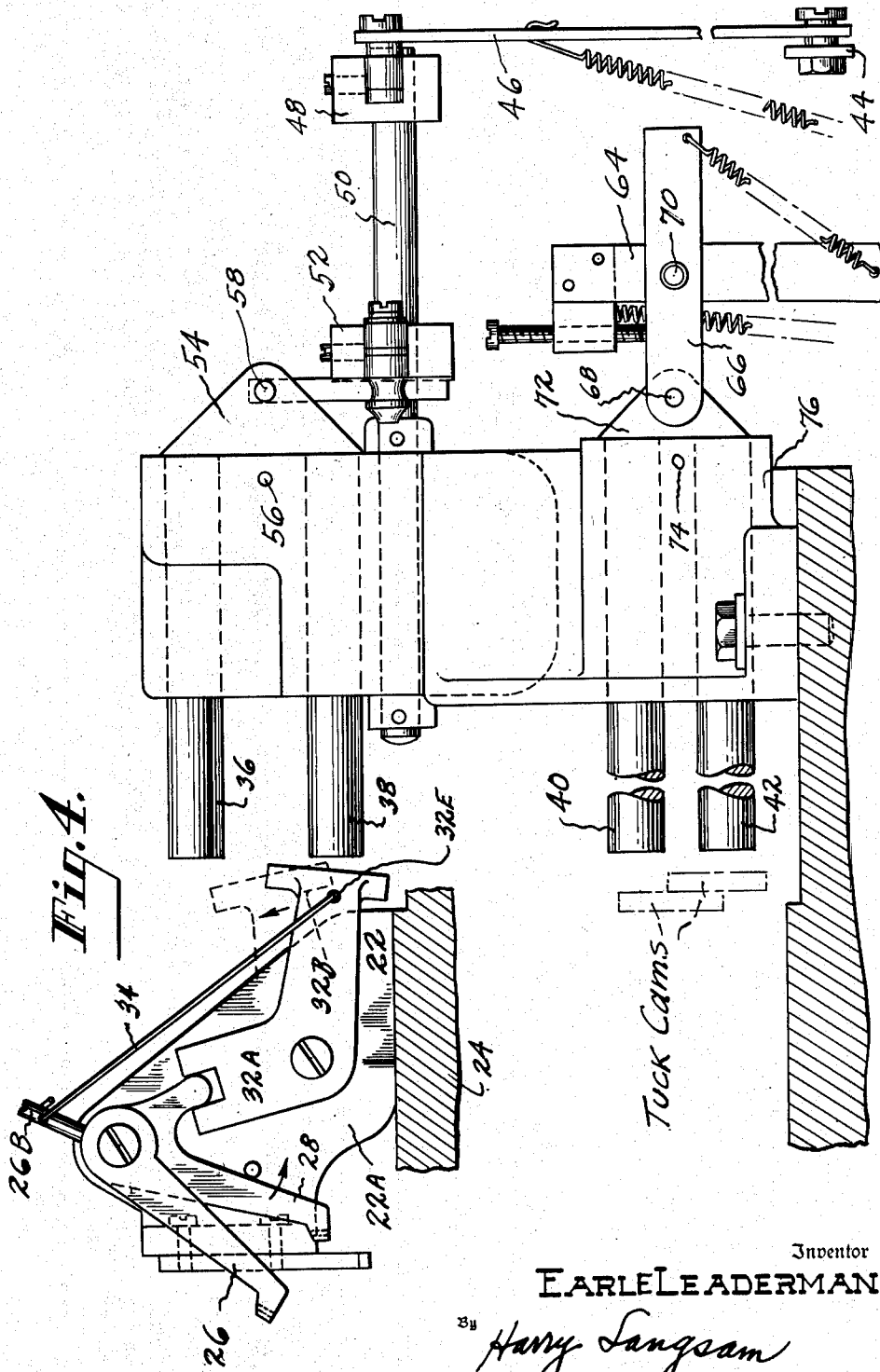

Fig. 4.

Inventor

EARLE LEADERMAN

By *Harry Langsam*

Attorney

Feb. 24, 1953

E. LEADERMAN

2,629,240

YARN CHANGING MEANS FOR CIRCULAR KNITTING MACHINES

Filed Feb. 8, 1950

5 Sheets-Sheet 3

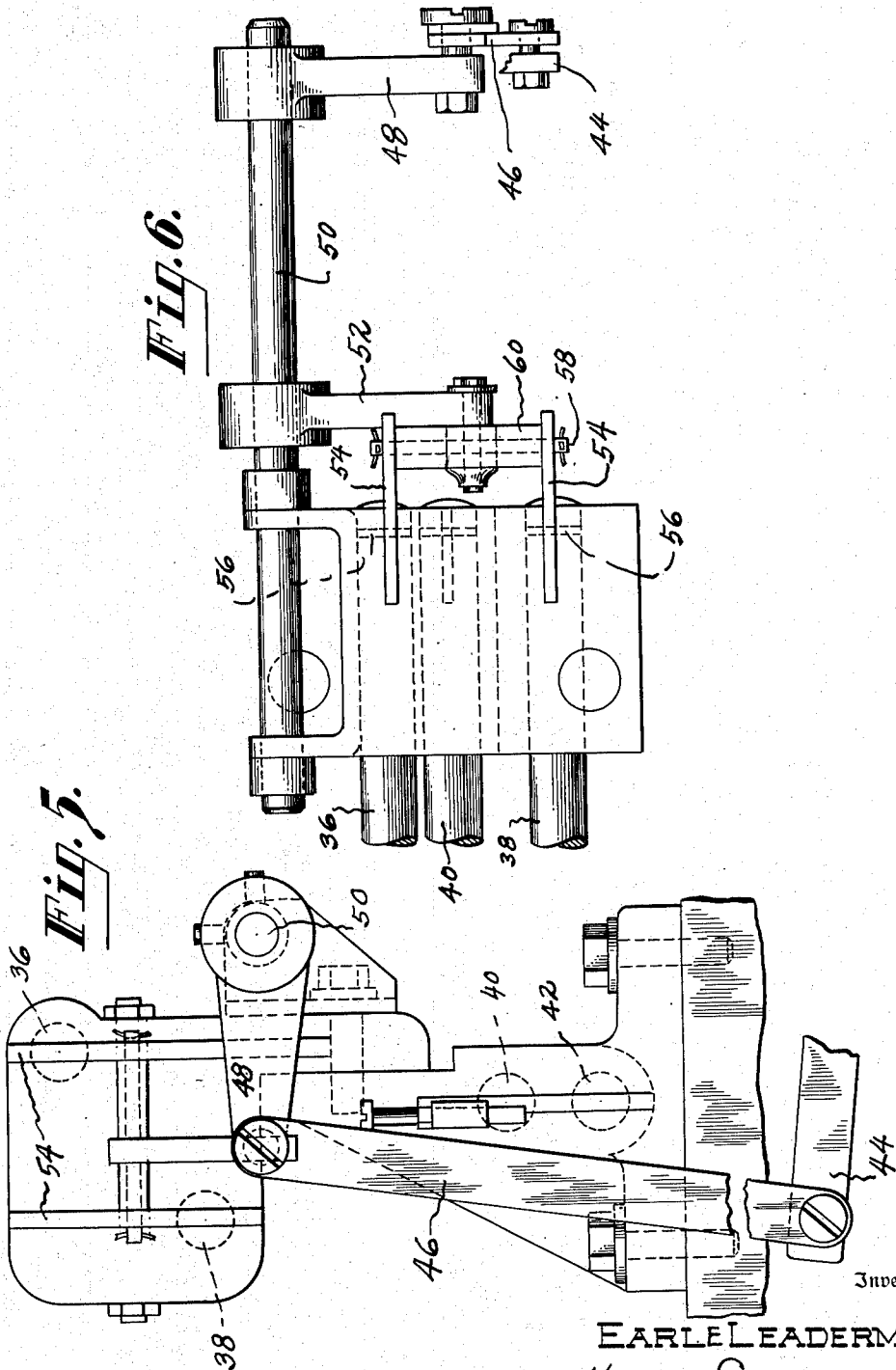

Inventor

EARLE LEADERMAN

By *Harry Sangsom*
Attorney

Feb. 24, 1953

E. LEADERMAN

2,629,240

YARN CHANGING MEANS FOR CIRCULAR KNITTING MACHINES

Filed Feb. 8, 1950

5 Sheets-Sheet 4

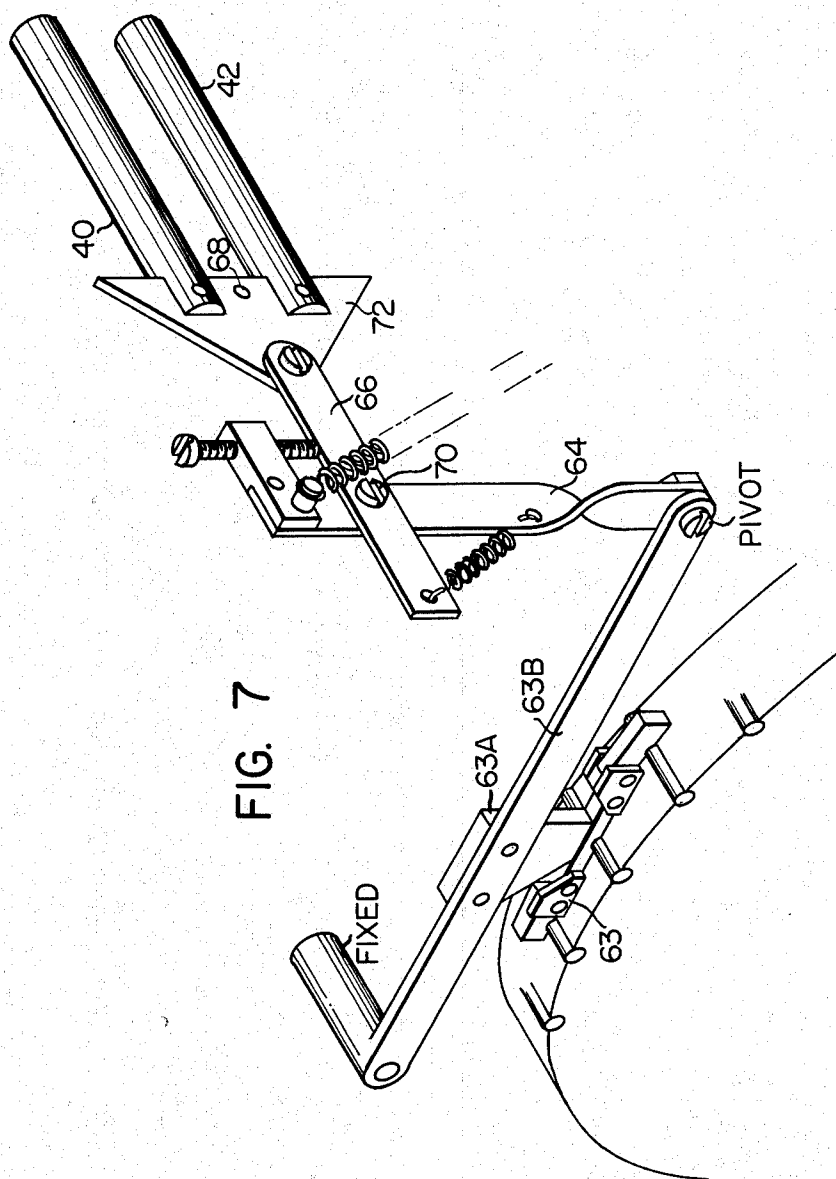

FIG. 7

INVENTOR.
EARLE LEADERMAN
BY *Harry Longsen*
ATTORNEY

Feb. 24, 1953

E. LEADERMAN

2,629,240

YARN CHANGING MEANS FOR CIRCULAR KNITTING MACHINES

Filed Feb. 8, 1950

5 Sheets-Sheet 5

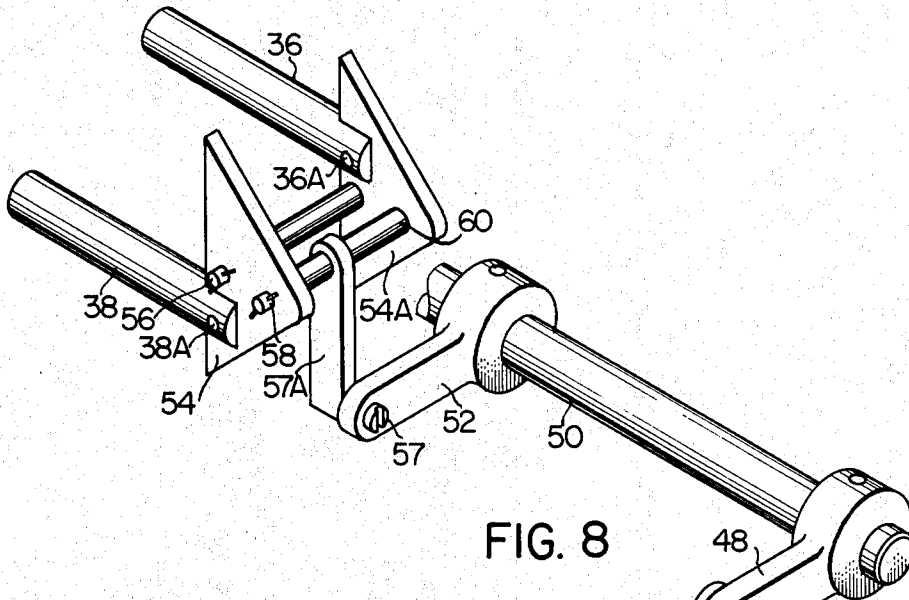

FIG. 8

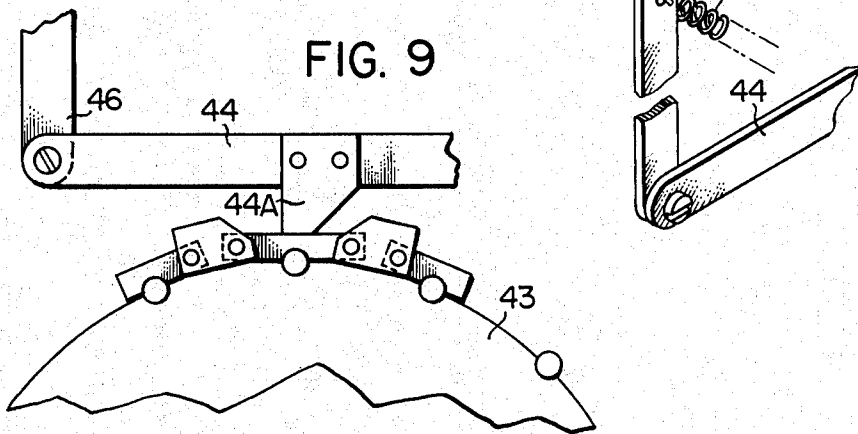

FIG. 9

INVENTOR.
EARLE LEADERMAN
BY
Harry Langsam
ATTORNEY

UNITED STATES PATENT OFFICE

2,629,240

YARN CHANGING MEANS FOR CIRCULAR KNITTING MACHINES

Earle Leaderman, Philadelphia, Pa., assignor to
Lee-Marc Fabrics, Philadelphia, Pa., a part-
nership

Application February 8, 1950, Serial No. 143,060

4 Claims. (Cl. 66—50)

1

My invention relates to knitting and relates particularly to knitting on a sinker top circular knitting machine such as the H. Brinton Company "Selective striping machine," style SS.

My invention is specifically employed to alter-
5 nate the feeding of different colored yarns to
knitting needles without altering the speed of
the knitting machine. My invention embodies a
pattern controlled yarn changer wherein a plu-
10 rality of movable yarn-feeding members are
actuated by pre-arranged pattern mechanisms
for changing the yarn supply to the needles of
the machine.

Since the Brinton machine under discussion
contains thirty-two feeds, the utilization of my
invention enables thirty-two feeds of two dif-
ferent colors to be instantly employed when the
color of the yarn fed is changed to the other
color or vice versa, thereby increasing the pro-
20 duction over the prior art devices.

Heretofore, all types of predetermined color
combinations could be knitted on the circular
knitting machine using only those feeds carry-
ing the desired color. However, with my inven-
tion, I have been able to rapidly change yarns
without idling as many yarn feeds, thereby main-
taining a greater production and obtaining new
and novel designs, by inter-changing color com-
binations among sixty-four cones of yarn instead
of thirty-two cones as on prior machines.

It, therefore, is an object of my invention to
provide a yarn changer for a circular knitting
machine.

It is another object of my invention to provide
a yarn changer for a circular knitting machine
wherein the yarn changer will be cam actuated.

Another object of my invention is to provide
a circular knitting machine wherein numerous
color combinations may be knitted together to
form an attractively colored fabric.

Another object of my invention is to increase
the productive capacity of a circular knitting
machine where different color combinations are
employed.

Other objects of my invention are to provide
45 an improved device of the character described,
that is easily and economically produced, which
is sturdy in construction, and which is highly
efficient in operation.

With the above and related objects in view,
my invention consists in the details of the con-
struction and combination of parts, as will be
more fully understood from the following de-
scription, when read in conjunction with the
accompanying drawings, in which:

2

Fig. 1 is a perspective view of a circular knit-
ting machine embodying my invention.

Fig. 2 is a perspective view of my yarn changer
wherein a yarn is in each changer but wherein
one yarn is used to be knitted to form the fabric
whereas the other yarn is held in an idle position.

Fig. 3 is a perspective view of the yarn changer
wherein the yarn used in knitting in Fig. 2 has
been cast out of knitting position and a new yarn
substituted.

Fig. 4 is a side view showing the yarn changer
and a side view of part of the pattern mechanism.

Fig. 5 is a rear view of a part of the pattern
mechanism.

Fig. 6 is a top view of the pattern mechanism
of Fig. 5.

Fig. 7 is a perspective view showing the mecha-
nism for actuating the plungers.

Fig. 8 is a fragmentary perspective view show-
20 ing the mechanism for actuating a pair of cylin-
drical rods or plungers.

Fig. 9 is a fragmentary view which shows the
pattern generally for controlling the cams which
elevate or lower the cylinder knitting needles.

Referring now in detail to the drawings where-
in similar reference characters refer to similar
parts, I show in Fig. 1 a circular knitting machine
of the "S. S. style" of selective striping ma-
chine manufactured by the H. Brinton Com-
pany. This invention may be suitably adapted
30 to machines of the same class that are manu-
factured by manufacturers other than Brinton.

The circular knitting machine comprises a base
assembly 10, a pattern mechanism 12, a fabric
take-up tension assembly 14, cylinder and dial
plate assembly 16, a head and cam ring assem-
bly 18, and a motor driven assembly 20.

A cylinder is mounted upon a gear ring, which
is driven in the customary manner and rotatably
carried to a bed plate, and a dial is mounted in
the well-known manner and driven in unison
with the needle cylinder. The yarn changing
means or striping unit, generally designated as
A, is carried upon a single bracket 22, having a
vertical arm 22A, fixedly mounted upon the bed
plate 24. A table holding the yarn, generally
designated as B, which usually is able to accom-
modate thirty-two cones is enlarged to hold
sixty-four cones. There are provided tension de-
vices, guides, etc., which will not be described
in detail.

The striping unit or yarn changer comprises
a pair of yarn feeds 26, 28, mounted upon the
same horizontally located pivot 30, which is car-
ried by the vertical arm 22A of the bracket 22.

3

The yarn carrying arm 28 has a small opening or eye 28A at its lower end through which one colored yarn B is threaded and it has integrally formed therewith a shorter cam-like arm 28B which is the actuating arm for the yarn feeder arm 28. The arm 28B interfits with a bifurcated end 32A of the pivoted cam bell-crank lever 32 which has an arrow-like cam end defined by two converging surfaces 32C and 32D. The cam arm 32 is pivoted at 33 so that oscillation of the cam arm 32B results in oscillation of the yarn feeder arm 28 from yarn laying or yarn registering position to yarn non-registering or idle position—that is the bell-crank lever 32 controls the location of the yarn feeder arm 28.

The second arm 26 having an eye or opening 26A through which the yarn B passes carries a short pin 26B to which a rigid rod 34 is attached. The other end of the rod 34 is attached at 32E to the arm 32B of the control lever 32. It is to be noted that the bell crank lever 32 is able to move either arm 26 or 28 to a predetermined position of yarn laying or yarn idling. Since both arms work reciprocally, one must move yarn into knitting position as the other moves into idling position. When one yarn changer arm moves the other arm moves in unison and the limiting in movement is limited by a stop pin 35.

The particular yarn B which is to be laid upon the needle is controlled by a pattern mechanism 12.

A pair of cylindrical rods or plungers 36, 38 controlled by the pattern mechanism are adapted to engage at different times, the surfaces 32C and 32D of the lever 32, respectively. The plungers 36, 38 are independently controlled as contrasted to the plungers 40, 42 which are also attached to a pattern mechanism for controlling the striping cams. The striping cams are located beneath the platform 24 and are adapted to engage the knitting needles, generally designated as N. By the use of the independent controls for the striping cams and for the knitting or tucking cams, a greater versatility of the use of the machine can be obtained.

It is to be noted that in the prior art machines where two colors were used on the feeds that in a thirty-two feed machines that only sixteen feeds could be used at one time, whereas in my invention I am able to use thirty-two feeds of the same color so that greater production can be achieved on a machine embodying my invention than with machines of the prior art. I also provide an independent striping control so that the machine has a greater versatility.

In the prior art a single pattern chain was used to control the cam which elevates or lowers the cylinder knitting needles, as well as the yarn feeds. This resulted in a cycle of events wherein the yarn idling occurred at a time the needle cams were lowered out of action with the result no knitting was performed. However, with my invention, embodied in a sinker top circular knitting machine I utilize a separate pattern chain for the yarn feeding and a separate pattern chain for controlling the cams which elevate or lower the cylinder knitting needles. The yarn feeding and knitting operations continue even during the interval of time when the yarn changing action comes into play.

This continuous knitting operation is brought about by keeping the cylinder needles elevated with the raised cam and transferring color yarn only by the yarn feed. The importance of having independent yarn feed mechanism control

4

and independent needle elevating control is that greater productivity is obtained as contrasted to a single yarn feed and needle elevating control.

The reason being that the needles where independent controls are employed need not be taken out of knitting position when there is a change-over from one yarn feed to another yarn feed. If a single control for both the yarn feeds and the needle elevating mechanism were used then the needles would have to be taken out of knitting position when the change is made from one yarn to another yarn. By idling the needles is meant the needles are not raised to take additional yarn and retain the stitch they hold.

It is to be noticed that a foot piece 44A on a rod 44 rests upon the links of a separate pattern chain mounted on a member 43 so that high, low, or neutral links elevate the rod 44 that is pivotally connected to a link 46. The other end of the link 46 is pivotally connected to one end of a lever 48 that is rigidly affixed to a shaft 50. A second lever 52 having one end rigidly affixed to the shaft 50 rotates or oscillates in unison with the shaft 50 and the lever 48. The other end of the second lever 52 is pivoted at 57 to an intermediate lever 57A that is also pivoted to a cross pin 60. The cross pin 60 extends at right angles to the intermediate lever 57A but both move in unison upwardly and downwardly. One end of the cross pin 60 is pivotally connected at 58 to a member 54 and the other end of the cross pin 60 is pivotally connected to a second member 54A which is similar in construction and function as the member 54. The member 54A has plunger 36 pivotally connected at the upper end thereof at 36A and the member 54A oscillates about a pivot 56. The pivot 36A is above the pivot 56. It should be noted that a pull downwardly on the rod 60 oscillates the member 54A about the pivot 56 thereby pulling the plunger 36 out of action. On the other hand when the rod 60 is moved upwardly the member 54A oscillates about the pivot 56 pushing the plunger 36 into action whereby it will be engaged by the surface 32C of the bell crank lever 32. The plunger 38 is pivotally connected at 38A below the pivot 56 of the member 54 so that a pull downwardly on the rod 60 causes the pivotal connection at 58 to oscillate downwardly about the pivot 56 so that the plunger 38 moves into a position to engage the surface 32D of the bell crank lever 32. A movement upwardly of the rod 60 causes the plunger 38 to be pulled out of action.

It is observed that the rod 60 moves the members 54, 54A simultaneously about the pivots 56, 56 and that a movement downwardly of the rod 60 pulls the upper plunger 36 out of action and moves the lower plunger 38 into action simultaneously. A movement upwardly of the rod 60 causes the plunger 36 to be moved into action and the plunger 38 pulled out of action simultaneously.

A second independent pattern chain 63 (Fig. 7) of conventional construction engages a foot piece 63A on a pivoted lever 63B. The movable end of the lever 63B has a vertical link 64 attached thereto and a second link 66 which is pivoted to the horizontal link 64 at 70. The free end of the link 66 is pivoted to a strip 72 which is pivoted at 68 so that movement of the strip 72 idles one or the other of the plungers 40, 42, each of which is pivotally attached. The plungers 40, 42 elevate or depress the cams which raise or lower the cylinder knitting needles.

The plungers 40, 42 move radially of the needle

5

cylinder and one or the other of the plungers 40, 42 is adapted to be in the path of the converging surfaces so that the tuck cam arm may oscillate.

The plungers 36, 38 likewise move radially of the needle cylinder and one or the other may be abutted or engaged by the cam surfaces 32C or 32D to oscillate the cam arm 32.

Although my invention has been described in considerable detail, such description is meant to be illustrative, rather than limiting, as the invention may be variously embodied, and the scope of the invention is to be determined as claimed.

I claim as my invention:

1. In a sinker top circular knitting machine having a plurality of knitting needles, a plurality of striping units, each striping unit having a pair of yarn feeds wherein each of said yarn feeds are synchronously actuated whereby only one yarn feed supplies yarn to said needles at one time and the second yarn feed is idle, a pivoted cam having a forked arm, one of said yarn feeds having an arm interfitting with said forked arm of said cam whereby the movement of said cam actuates the yarn feed either to yarn feeding or yarn idling position, and means connected to said cam to actuate a second feed to the converse positions of the other yarn feed.

2. The invention of claim 1 including a pair of plungers only one of which is in actuating position at any one period of time, said pivoted cam being engageable by one or the other of said plungers to place one of said yarn feeds of each striping unit in yarn feeding position at any one period of time.

3. The invention of claim 1 wherein an independent pattern chain controls the yarn feeds, means to elevate or lower said knitting needles,

6

and a second independent pattern chain to control the elevating or lowering of said knitting needles at all times.

4. In a sinker top circular knitting machine having a plurality of knitting needles, a plurality of striping units, each striping unit having a pair of yarn feeds wherein each of said yarn feeds are synchronously actuated whereby only one yarn feed supplies yarn to said needles at one time and the other yarn feed is idle, a pivoted cam having a forked arm at one end thereof, one of said yarn feeds having an arm interfitting with said forked arm of said cam whereby the movement of said cam actuates the yarn feed either to yarn feeding or yarn idling position, means connected to said cam to actuate a second feed to the converse positions of the other yarn feed, and means to actuate said cam to control one yarn feed and idle the other feed.

EARLE LEADERMAN.

REFERENCES CITED

The following references are of record in the file of this patent:

UNITED STATES PATENTS

Number	Name	Date
383,817	Lamprey et al. -----	May 29, 1888
604,640	Scott -----	May 24, 1898
629,503	Hemphill -----	July 25, 1899
761,385	Langer -----	May 31, 1904
1,883,320	Aaronson -----	Oct. 18, 1932
1,883,337	Collar -----	Oct. 18, 1932
1,925,450	Levin -----	Sept. 5, 1933
1,929,125	Steere -----	Oct. 3, 1933
2,059,076	Aaronson -----	Oct. 27, 1936
2,189,276	Agulnek et al. -----	Feb. 6, 1940