

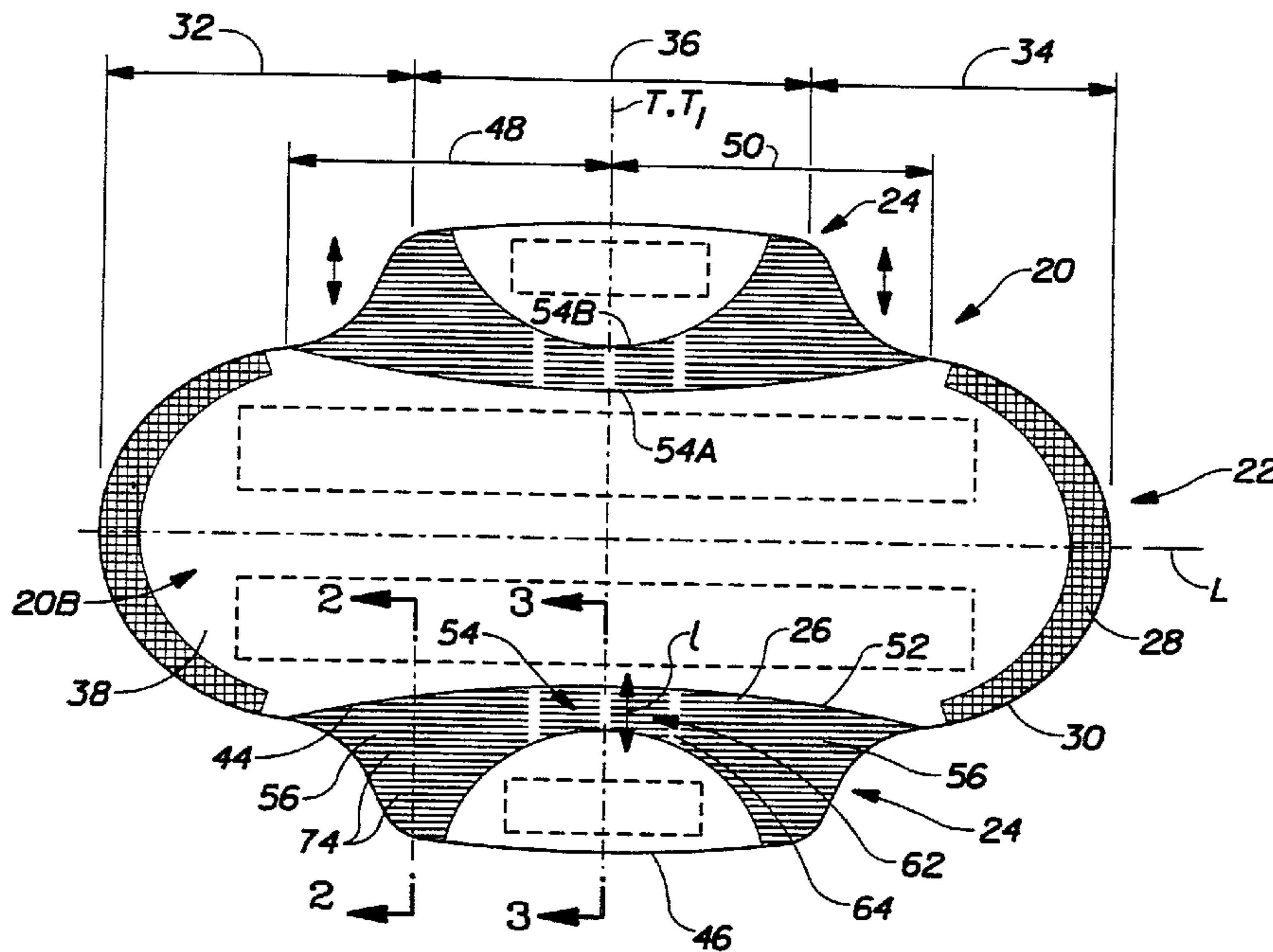

(86) Date de dépôt PCT/PCT Filing Date: 1996/10/01
 (87) Date publication PCT/PCT Publication Date: 1997/04/10
 (45) Date de délivrance/Issue Date: 2003/02/11
 (85) Entrée phase nationale/National Entry: 1998/04/03
 (86) N° demande PCT/PCT Application No.: US 1996/015647
 (87) N° publication PCT/PCT Publication No.: 1997/012576
 (30) Priorité/Priority: 1995/10/06 (08/539,915) US

(51) Cl.Int.⁶/Int.Cl.⁶ A61F 13/56
 (72) Inventeurs/Inventors:
 TERADA, NAMI, JP;
 OLSEN, ROBB ERIC, US;
 CHOW, SHIRLEY LEE, US;
 BAMBER, JEFFREY VINCENT, US
 (73) Propriétaire/Owner:
 THE PROCTER & GAMBLE COMPANY, US
 (74) Agent: SIM & MCBURNEY

(54) Titre : ARTICLE ABSORBANT COMPORTANT DES RABATS A ARTICULATION DEFORMEE ET DES ZONES EXTENSIBLES
 (54) Title: ABSORBENT ARTICLE HAVING FLAPS WITH A DEFORMED HINGE AND ZONES OF EXTENSIBILITY



(57) Abrégé/Abstract:

Absorbent articles such as sanitary napkins, panty liners, adult incontinence devices, and the like, which have flaps are disclosed. The absorbent articles have a deformed hinge that is located between at least a portion of the main body portion of the absorbent article and the flaps, and zones of extensibility for relieving the stresses that develop in the flaps when the flaps are folded down and under a wearer's undergarment.

PCTWORLD INTELLECTUAL PROPERTY ORGANIZATION
International Bureau

INTERNATIONAL APPLICATION PUBLISHED UNDER THE PATENT COOPERATION TREATY (PCT)

(51) International Patent Classification ⁶ : A61F 13/15	A1	(11) International Publication Number: WO 97/12576 (43) International Publication Date: 10 April 1997 (10.04.97)
(21) International Application Number: PCT/US96/15647 (22) International Filing Date: 1 October 1996 (01.10.96) (30) Priority Data: 08/539,915 6 October 1995 (06.10.95) US (71) Applicant: THE PROCTER & GAMBLE COMPANY [US/US]; One Procter & Gamble Plaza, Cincinnati, OH 45202 (US). (72) Inventors: TERADA, Nami; 2-9-22, Yahata-cho, Nada-ku, Hyogo, Kobe 657 (JP). OLSEN, Robb, Eric; 3214 Grischy Lane, Cincinnati, OH 45208 (US). CHOW, Shirley, Lee; 1 Mapleview Court, Cincinnati, OH 45236 (US). BAMBER, Jeffrey, Vincent; 5023 Village Drive, Cincinnati, OH 45244 (US). (74) Agent: REED, T., David; The Procter & Gamble Company, 5299 Spring Grove Avenue, Cincinnati, OH 45217 (US).		(81) Designated States: AL, AM, AT, AU, AZ, BA, BB, BG, BR, BY, CA, CH, CN, CU, CZ, DE, DK, EE, ES, FI, GB, GE, HU, IL, IS, JP, KE, KG, KP, KR, KZ, LC, LK, LR, LS, LT, LU, LV, MD, MG, MK, MN, MW, MX, NO, NZ, PL, PT, RO, RU, SD, SE, SG, SI, SK, TJ, TM, TR, TT, UA, UG, UZ, VN, ARIPO patent (KE, LS, MW, SD, SZ, UG), Eurasian patent (AM, AZ, BY, KG, KZ, MD, RU, TJ, TM), European patent (AT, BE, CH, DE, DK, ES, FI, FR, GB, GR, IE, IT, LU, MC, NL, PT, SE), OAPI patent (BF, BJ, CF, CG, CI, CM, GA, GN, ML, MR, NE, SN, TD, TG). Published <i>With international search report.</i> <i>Before the expiration of the time limit for amending the claims and to be republished in the event of the receipt of amendments.</i>

(54) Title: ABSORBENT ARTICLE HAVING FLAPS WITH A DEFORMED HINGE AND ZONES OF EXTENSIBILITY**(57) Abstract**

Absorbent articles such as sanitary napkins, panty liners, adult incontinence devices, and the like, which have flaps are disclosed. The absorbent articles have a deformed hinge that is located between at least a portion of the main body portion of the absorbent article and the flaps, and zones of extensibility for relieving the stresses that develop in the flaps when the flaps are folded down and under a wearer's undergarment.

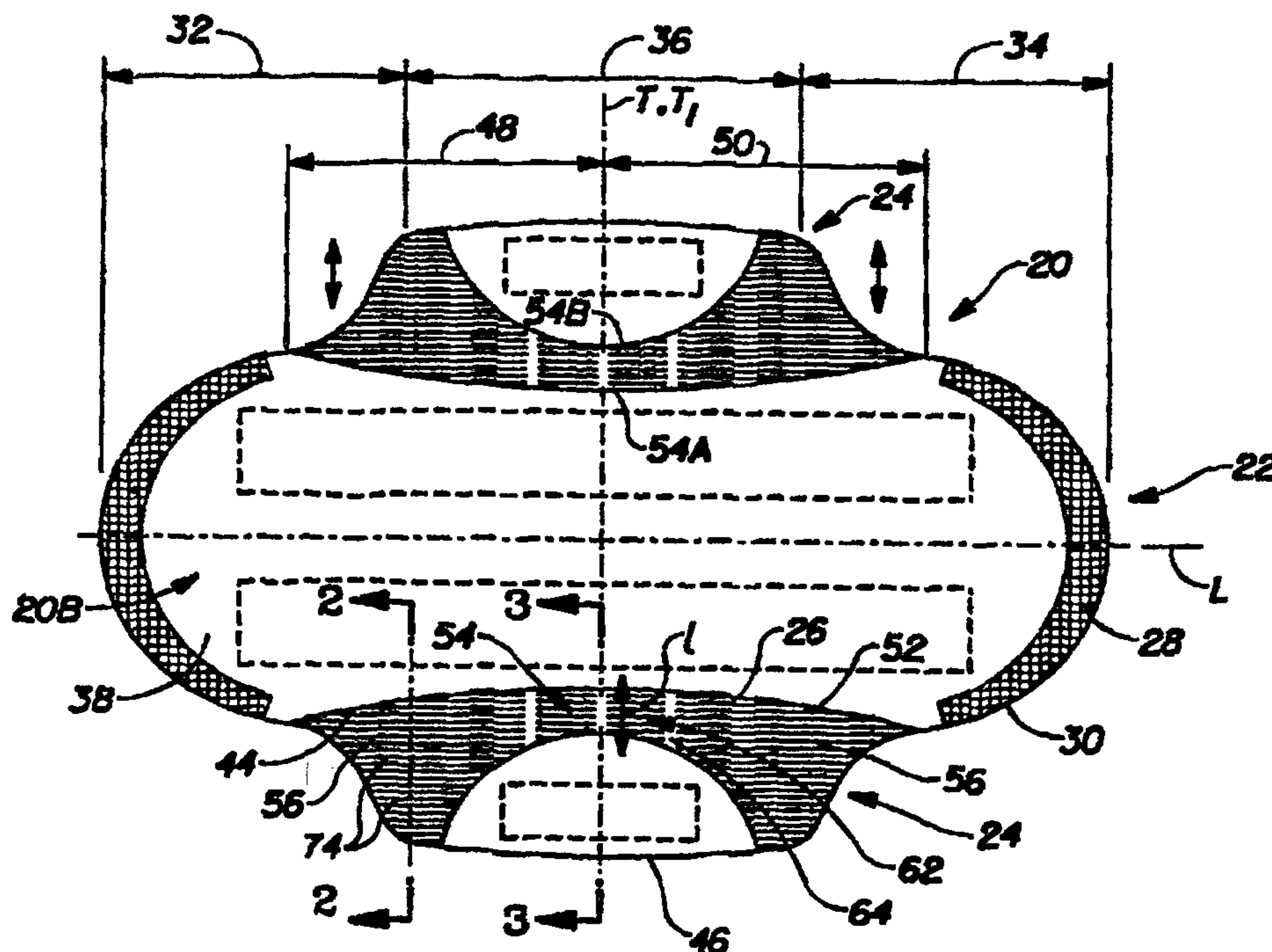

ABSORBENT ARTICLE HAVING FLAPS**WITH A DEFORMED HINGE AND ZONES OF EXTENSIBILITY****FIELD OF THE INVENTION**

The present invention relates to absorbent articles such as sanitary napkins, panty liners, adult incontinence devices, and the like. Still more particularly, the present invention concerns absorbent articles such as sanitary napkins, and the like having flaps with a deformed hinge and zones of extensibility for relieving the stresses that develop in the flaps when the flaps are folded down and under a wearer's undergarment.

BACKGROUND OF THE INVENTION

Absorbent articles, particularly sanitary napkins, having wings or flaps are disclosed in the patent literature and are available in the marketplace. Sanitary napkins having flaps of the various types are disclosed in U.S. Patent 4,687,478, entitled "Shaped Sanitary Napkin With Flaps", which issued to Van Tilburg on

August 18, 1987, U.S. Patent 4,608,047, entitled "Sanitary Napkin Attachment Means", which issued to Mattingly on August 26, 1986, U.S. Patent B1 4,589,876, entitled "Sanitary Napkin", which issued to Van Tilburg on May 20, 1986, U.S. Patent 4,285,343, entitled "Sanitary Napkin", which issued to McNair on August 25, 1981, U.S. Patent 3,397,697, entitled "Disposable Sanitary Shield For Undergarments", which issued to Rickard on August 20, 1968, and U.S. Patent 2,787,271, entitled "Sanitary Napkin", which issued to Clark on April 2, 1957.

A number of variations on the types of flaps described above have been presented in an attempt to solve various problems. U.S. Patent 4,900,320 issued to McCoy on February 13, 1990, discloses a sanitary napkin having flaps affixed at points inward from the longitudinal edge of the napkin. U.S. Patent 4,911,701 issued to Mavinkurve on March 27, 1990, discloses a sanitary napkin having elastic means for providing greater convex shape to the body-facing portion of the central absorbent and for enabling adhesive-free placement of the flaps of the napkin. U.S. Patent 4,940,462 issued to Salerno on July 10, 1990, discloses a sanitary napkin with longitudinally expandable flaps. A sanitary napkin having flaps with stress relief means in the form of a notch or a slit is described in U.S. Patent 4,917,697 which issued to Osborn, III, et al. on April 17, 1990. U. S. Patent 5,389,094 issued to Lavash et al. on February 14, 1995, discloses sanitary napkins (and other types of absorbent articles) having flaps and zones of differential extensibility. Although these latter sanitary napkins work quite well, the search for sanitary napkins that are more cost effective, as well as those which have improved flaps has continued.

SUMMARY OF THE INVENTION

In accordance with the present invention, an absorbent article, such as a sanitary napkin, is provided. The sanitary napkin has flaps with a deformed hinge and zones of extensibility for relieving the stresses that develop in the flaps when the flaps are folded around and under the edges of the crotch of the wearer's panties.

The sanitary napkin has a principal longitudinal centerline and a principal transverse centerline. The sanitary napkin comprises a main body portion and a pair

of flaps joined to the main body portion. The main body portion Of the sanitary napkin comprises a liquid pervious topsheet, a liquid impervious backsheet joined to the topsheet, an absorbent core positioned between the topsheet and the backsheet. The main body portion has two spaced apart longitudinal edges and two spaced apart transverse end edges.

The flaps are each joined to the main body portion at a juncture. The flaps extend laterally outward from at least a central region of the main body portion beyond the longitudinal side edges of the main body portion. In one preferred embodiment, the flaps are integral extensions of the topsheet and backsheet. The flaps are divided into a front half and a back half by a flap transverse centerline. The flaps each have two corner regions which are located adjacent the area of the ends of the junctures of the flaps with the main body portion. One corner region is located adjacent the area of the juncture in each direction remote from the principal transverse centerline. The sanitary napkin comprises a deformed hinge (or bending zone) located in a region that includes the juncture of the flaps with the main body portion and zones of differential extensibility in the corner regions of the flaps. The deformed hinge provides at least one axis about which the flaps may fold relative to the main body portion. The zones of differential extensibility allow the corner regions to extend outward (preferably in a generally transverse direction) to provide a means for the relief of stresses that develop in the flaps of the sanitary napkin when the sanitary napkin are folded down and under a wearer's undergarments.

In an alternative embodiment, at least a portion of the deformed hinge comprises a portion of the sanitary napkin which has a strainable network formed therein. The strainable network comprises at least two visually distinct regions. The network is configured so that at least one of the regions, the second regions, have a surface-pathlength (dimension measured along the surface) which is greater than that of the other regions, the first regions. The second regions exhibiting the longer surface-pathlength preferably comprise one or more rib-like elements. The first regions with the shorter surface-pathlength are preferably substantially planar. In this embodiment, the portion of the deformed hinge comprising this type of strainable network is preferably located at least in the region of the flap transverse centerline.

In accordance with a further embodiment, an absorbent article for wearing a crotch region of an undergarment, the crotch region having a pair of side edges, the absorbent article having a liquid pervious body-facing side,

3a

a liquid impervious garment side, a principal longitudinal centerline extending in a longitudinal direction, and a principal transverse centerline extending in a transverse direction, the absorbent article comprises:

a main body portion having a central region, two spaced apart longitudinal side edges and two spaced apart end edges, the main body portion comprising an absorbent core positioned between the body-facing side and the garment side;

a pair of flaps for folding around the side edges of the crotch region of undergarment, the flaps being joined to the main body portion, each flap extending laterally outward along one of the longitudinal side edges to a distal edge, the flaps each having a flap transverse centerline that passes through the central region of the main body portion;

a deformed region comprising a portion of the absorbent article that has planar portions and at least some portions that are displaced in a direction perpendicular to the planar portions, wherein the deformed region is substantially free of overlapping portions, and the deformed region forms a hinge between the main body portion and the flaps; and

at least one zone of extensibility comprising at least a portion of at least one of the flaps, wherein at least a portion of the zone of extensibility is spaced longitudinally away from the flap transverse centerline,

wherein the deformed hinge region and the at least one zone of extensibility are contiguous and form a composite region, the composite region having a proximal boundary which is concave relative to the distal edge of the flap and a distal boundary which is

3b

also concave relative to the distal edge of the flap, and the distal boundary has a lesser radius of curvature than the proximal boundary of the composite region, and

wherein the portion of the flaps outboard of the distal boundary of the composite region is a generally semi-circular area that is undeformed and stiffer than the composite region.

In accordance with another embodiment, an absorbent article having a liquid pervious body-facing side, a liquid impervious garment side, a principal longitudinal centerline extending in a longitudinal direction, and a principal transverse centerline extending in a transverse direction, the absorbent article comprises:

a main body portion having a central region, two spaced apart longitudinal side edges and two spaced apart end edges, the main body portion comprising an absorbent core positioned between the body-facing side and the garment side;

a pair of flaps joined to the main body portion, each flap extending laterally outward along one of the longitudinal side edges to a distal edge, the flaps each having a flap transverse centerline that passes through the central region of the main body portion and points along the flap transverse centerline;

a deformed region comprising a portion of the absorbent article that forms a hinge between the main body portion and at least a portion of the flaps, wherein the deformed region comprises a plurality of corrugations and the corrugations comprise ridges that are generally oriented in the longitudinal direction, and the hinge has a proximal boundary which is concave relative to the distal edge of the flaps; and

3c

a zone of extensibility comprising at least a portion of at least one of the flaps, wherein at least a portion Of the zone of extensibility is spaced longitudinally away from the flap transverse centerline and the zone of extensibility comprises a plurality of corrugations, at least some of which are contiguous with the corrugations forming the hinge.

BRIEF DESCRIPTION OF THE DRAWINGS

Figure 1 is a top plan view of a preferred sanitary napkin embodiment of the present invention.

Figure 2 is a lateral cross-sectional view taken along line 2-2 of Figure 1 through the corner region of one of the flaps of the sanitary napkin.

Figure 3 is a lateral cross-sectional view taken along line 3-3 of Figure 1 through the center portion of one of the flaps.

Figure 4 is a perspective view of the crotch portion of a woman's panties with the sanitary napkin shown in FIGS. 1-3 in place therein.

Figure 5 is a top plan view of a web material having a strainable network of the type used in the deformed hinge of the sanitary napkin shown in FIGS. 1-3, the web material being shown in a substantially untensioned condition.

Figure 6 is an enlarged segmented perspective illustration of the web material shown in Figure 5 in which the web material is in a substantially untensioned condition.

Figure 7 is an enlarged segmented perspective illustration of the web material shown in Figure 5 in which the web material is subjected to tension in an amount which is sufficient for a substantial portion of the deformations of the web material to enter the plane of applied elongation.

Figure 8 is an enlarged segmented perspective illustration of the web material shown in Figure 5 in which the web material is in a condition in which it will exhibit a second stage of resistive forces to elongation.

DETAILED DESCRIPTION OF THE INVENTION

The present invention relates to absorbent articles that are worn in an undergarment, such as sanitary napkins, panty liners, incontinence devices, and the like. More particularly, the present invention relates to absorbent articles having flaps with a deformed hinge and zones of extensibility for relieving the stresses that develop in the flaps when they are folded down and under a wearer's undergarment.

A preferred embodiment of a sanitary napkin 20 of the present invention is shown in FIG. 1. As shown in FIG. 1, the sanitary napkin 20 basically comprises an absorbent means (or "main body portion") 22, and two flaps 24. The sanitary napkin 20 has two surfaces, a body-contacting surface or "body surface" 20A and a garment surface 20B. The sanitary napkin 20 is shown in FIG. 1 as viewed from its body surface 20A. The body surface 20A is intended to be worn adjacent to the wearer's body. The garment surface 20B is intended to be placed adjacent to the wearer's undergarments when the sanitary napkin 20 is worn.

The sanitary napkin 20 has two centerlines, a principal longitudinal centerline L and a principal transverse centerline T. The term "longitudinal", as used herein, refers to a line, axis or direction in the plane of the sanitary napkin 20 that is generally aligned with (e.g., approximately parallel to) a vertical plane which bisects a standing wearer into left and right body halves when the sanitary napkin 20 is worn. The terms "transverse" or "lateral" used herein, are interchangeable, and refer to a line, axis or direction which lies within the plane of the sanitary napkin 20 that is generally perpendicular to the longitudinal direction.

FIG. 1 shows that the main body portion 22 of the sanitary napkin 20 comprises the portion of the sanitary napkin without the flaps 24. The main body portion 22 has two spaced apart longitudinal edges 26, two spaced apart transverse or end edges (or "ends") 28, which together form the periphery 30 of the main body portion. The main body portion 22 also has two end regions, which are designated first end region 32 and second end region 34. A central region 36 is disposed between the end regions 32 and 34. The end regions 32 and 34 extend outwardly in the longitudinal direction from the edges of the central region 36 about 1/8 to about

1/3 of the length of the main body portion. A detailed description of the characteristics of a central region and two end regions for a sanitary napkin is contained in U.S. Patent 4,690,680 issued to Higgins on September 1, 1987.

The main body portion 22 of the sanitary napkin 20 can be of any thickness, including relatively thick, intermediate thickness, relatively thin, or even very thin (or "ultra thin"). An "ultra-thin" sanitary napkin 20 as described in U.S. Patents 4,950,264 and 5,009,653 issued to Osborn preferably has a caliper of less than about 3 millimeters. The embodiment of the sanitary napkin 20 shown in the drawings is intended to be an example of a sanitary napkin of an intermediate thickness. The main body portion 22 of the sanitary napkin 20 may also be relatively flexible, so that it is comfortable for the wearer. It should be understood that the sanitary napkin shown is merely one embodiment, and that the present invention is not limited to absorbent articles of the type or having the specific configurations shown in the drawings.

FIG. 2 shows the individual components of the main body portion 22 of the sanitary napkin 20 of the present invention. The main body portion 22 of the sanitary napkin preferably comprises at least three primary components. These include a liquid pervious topsheet 38, a liquid impervious backsheet 40, and an absorbent core 42 positioned between the topsheet 38 and the backsheet 40. The topsheet, the backsheet, and the absorbent core may be assembled in a variety of configurations known in the art (including layered or "sandwich" configurations and wrapped or "tube" configurations).

Suitable materials for the components of the main body portion 22, and some of the various configurations in which such components can be assembled are described generally in U.S. Patent 4,321,924, "Bordered Disposable Absorbent Article" issued to Ahr on March 30, 1982; U.S. Patent 4,425,130, "Compound Sanitary Napkin" issued to DesMarais on January 10, 1984; U.S. Patent 4,950,264, "Thin, Flexible Sanitary Napkin" issued to Osborn on August 21, 1990; U.S. Patent 5,308,346, "Elasticized Sanitary Napkin" issued to Sneller, et al. on May 3, 1994; and U.S. Patent 5,389,094 "Absorbent Article Having Flaps and Zones of Differential Extensibility" issued to Lavash, et al. on February 14, 1995. The main

body portion 22 of the sanitary napkin may also be comprised of one or more extensible components such as those sanitary napkins, and the like described in U.S. Patent No. 5,824,004 (PCT Publication No. WO93/01785) and PCT Publication No. 93/01786.

Figures 1-3 show a preferred embodiment of the sanitary napkin 20 assembled in a sandwich construction in which the topsheet 38 and the backsheet 40 have length and width dimensions generally larger than those of the absorbent core 42. The topsheet 38 and the backsheet 40 extend beyond the edges of the absorbent core 42 to form portions of the periphery 30. The topsheet 38 is preferably joined to the body-facing side of the absorbent core 42 and the backsheet 40 is preferably joined to the garment-facing side of the absorbent core. The topsheet 38 and backsheet 40 can be joined to the absorbent core in any suitable manner known in the art for this purpose, such as by an open pattern of adhesives. The portions of the topsheet 38 and backsheet 40 that extend beyond the edges of the absorbent core are preferably also joined to each other. The topsheet 38 and backsheet 40 can be joined in any suitable manner known in the art for this purpose. Preferably, in the embodiment shown, these portions of the topsheet 38 and backsheet 40 are joined using adhesives over substantially the entire portions that extend beyond the edges of the absorbent core 42, and a crimp seal at the end edges 28 of the main body portion where the topsheet 38 and backsheet 40 are densified by the application of pressure or heat and pressure.

The sanitary napkin 20 shown in FIGS. 1-3, as discussed above, also comprises a pair of flaps 24 that are joined to the main body portion 22. The flaps 24 extend laterally outward beyond the longitudinal side edges 22 of the main body portion 22 from their proximal edges 44 to their distal edges (or "free end") 46. The flaps 24 extend outward from at least the central region 36 of the main body portion 22. As shown in Figure 1, each flap 24 is divided into a front half 48, and a back half 50 by a flap transverse centerline T_1 . The flap transverse centerline T_1 may coincide with the principal transverse centerline T of the sanitary napkin, but this is not absolutely required.

The flaps 24 can be joined to the main body portion 22 in any suitable manner. The term "joined", as used herein, encompasses configurations in which an element is directly secured to another element by affixing the element directly to the other element; configurations in which the element is indirectly secured to the other element by affixing the element to intermediate member(s) which in turn are affixed to the other element; and configurations in which one element is integral with another element, i.e., one element is essentially part of the other element. Preferably, in the embodiment shown in FIGS. 1-3, the flaps 24 are integral with the main body portion 22 (that is, the flaps 24 comprise integral extensions of the topsheet 38 and backsheet 40).

In other alternative embodiments, the flaps 24 can comprise one or more separate components that are joined to the garment-facing side of the main body portion 22. Preferably, in such a case, the flaps 24 each comprise a separate component that is joined to the garment-facing side of the main body portion 22. In such alternative embodiments, the flaps 24 are preferably otherwise unattached to the garment-facing side of the main body portion 22 of the sanitary napkin 20 between the points where they are attached to the main body portion and the longitudinal side edges 26 of the main body portion. The flaps 24 in these latter embodiments can be joined to the garment-facing side of the main body portion 22 by any suitable attachment mechanism. Suitable attachment mechanisms include, but are not limited to adhesives, and the like.

The flaps 24 are each joined to (or associated with) main body portion 22 along a juncture. This is typically a longitudinally-oriented (or "longitudinal") juncture, such as lines of juncture 52. As used herein, the terms "juncture" (or "line of juncture") refer to regions where the flaps 24 extend from or are joined to the main body portion 22. These regions can be any of various curved or straight lines, but they are not limited to lines. Thus, these regions can comprise flanges, strips, intermittent lines, and the like. The line of juncture 52 in the embodiment illustrated in Figure 1 can be considered to be defined by concave inwardly-oriented regions or lines if the proximal edges 44 of the flaps 24 are considered to coincide with the inwardmost boundary of the hinge 54 (described below).

The sanitary napkin 20 shown in FIGS. 1-3 preferably has a deformed region that forms a hinge 54 between the main body portion 22 and at least a portion of the flaps 24. The sanitary napkin 20 preferably also has at least one zone of extensibility (or "zone of differential extensibility") 56 for relieving the stresses on the flaps 24 when they are folded around a panty crotch. These are each described below.

In the sanitary napkin shown in FIGS. 1 - 3, the hinge 54 comprises a generally longitudinally-oriented, mechanically-deformed region. The hinge 54 provides a region of the sanitary napkin 20 with increased flexibility to create preferred bending axes for the flaps 24 to bend or fold about. The hinge 54 is preferably located in a region along the juncture 52 of the flaps 24 with the main body portion 22. The hinge 54, however, does not have to coincide exactly with the juncture 52 of the flaps 24 with the main body portion 22. The hinge 54 can be located laterally inboard of the juncture 52 of the flaps with the main body portion 22, on the juncture, laterally outboard of the juncture, or any combination of the foregoing. If the hinge 54 is located laterally inboard of the juncture or on the juncture, the hinge 54 may be considered to be formed in at least part of the main body portion 22 (and, in the latter case, also in part of the flaps 24).

The hinge 54 can extend along the entire juncture 52 of the flaps with the main body portion, or along only a portion thereof. If the hinge 54 is only provided along a portion of the juncture 52, it is preferably provided in the region of the sanitary napkin 20 surrounding and including the flap transverse centerline. The hinge 54 can be in many possible configurations. The hinge 54 can comprise a continuous region, or a plurality of spaced apart intermittent regions. The hinge 54 can be rectilinear, curvilinear, or it can comprise portions that are rectilinear and portions that are curvilinear. The hinge 54 has a laterally inwardmost, or proximal, boundary 54A and an outermost, or distal, boundary 54B. In the embodiment shown in FIGS. 1-3, at least the inwardmost boundary 54A of the hinge 54 is preferably concave inwardly relative to the distal edge of the flaps 54.

The hinge 54 can be formed in any suitable manner that provides the desired region of the sanitary napkin with increased flexibility. Preferably, the hinge 54 is

formed by mechanically deforming the desired regions of the sanitary napkin. It has been found that many processes suitable for providing regions of the sanitary napkin with extensibility are particularly suitable for providing regions of the sanitary napkin 20 selected for the hinge 54 with enhanced flexibility.

The hinge 54 can, for instance, be formed by a process which has been described as pre-corrugating (or "ring rolling"). Suitable methods for ring rolling are described in U.S. Patent 4,107,364 issued to Sisson on August 15, 1978, U.S. Patent 4,834,741 issued to Sabee on May 30, 1989, U.S. Patent 5,143,679 issued to Gerald M. Weber, et al. on September 1, 1992, U.S. Patent 5,156,793 issued to Kenneth B. Buell, et al. on October 20, 1992, and U.S. Patent 5,167,897 issued to Gerald M. Weber, et al. on December 1, 1992.

Alternatively, as shown in FIG. 1 for purposes of illustration, the hinge 54 is provided by forming a strainable network in the region along the juncture 52 of the flaps 24 with the main body portion 22. The process for forming a strainable network region, and structures formed thereby are described in greater detail below in conjunction with FIGS. 5-8. This technology is further described in allowed U.S. Patent No. 5,518,801 (PCT Publication No. WO95/03765, published February 9, 1995).

These structures (ring rolled structures and materials with strainable network regions formed therein) are especially preferred for the hinge 54 because the alternating ridges and valleys can form a plurality of flexible bending axes for the flaps 24. These types of structures also provide the hinge 54 with a degree of extensibility. The extensibility allows the portions of the flaps 24 in the hinge region 54 to expand slightly in the transverse direction to better fold around the curved sides of the wearer's panty crotch. Providing the hinge 54 by forming strainable network regions in the sanitary napkin may also be preferred when it is desired to provide the formed regions with slightly more integrity so the flaps 24 will be less likely to droop excessively at the hinge 54 because the unformed first regions or less extensible bands 64 (described below) of the strainable network will serve like "beams" that tend to provide the flaps 24 with slightly more structural rigidity and better appearance.

The process of forming a strainable network is preferred for providing the sanitary napkin 20 with a hinge 54 because (like ring rolling) such an operation can be readily adapted for use in high speed manufacturing operations. Further, the process of forming a strainable network in a material is highly preferred because it can be adapted to produce a virtually unlimited number of patterns to tailor the configuration and characteristics of the hinge 54 and zones of extensibility 56.

Typically, the base material into which the strainable network is formed comprises a single layer of material or laminate of materials, at least one of which is a film. Preferably, in the embodiment shown in FIGS. 1-3, the material that has the strainable network formed therein comprises a laminate formed by an extension of the topsheet and backsheet 40 of the sanitary napkin. The topsheet 38 preferably comprises an apertured formed film made in accordance with U.S. Patents 4,342,314, Radel, et al. and 4,463,045, Ahr, et al. which is marketed on sanitary napkins as DRI-WEAVE* by The Procter & Gamble Company and a polyethylene film. The two components are preferably laminated together by adhesives.

The characteristics of the strainable network 62 in the hinge 54 of the sanitary napkin shown in FIGS. 1-3 will be discussed with reference to FIGS. 5-8. FIGS. 5-8 are enlarged views of a simplified version of a web material 60 having a strainable network 62 formed therein. The term "strainable network", as used herein, refers to an interconnected and interrelated group of regions which are able to be extended to some useful degree in a predetermined direction. FIGS. 5 and 6 show the web material 60 in an untensioned condition. The strainable network 62 comprises at least two distinct and dissimilar regions which are designated as first region 64 and second region 66.

In the simplified embodiment shown in FIGS. 5 and 6, the web material 60 includes a plurality of first regions 64 and a plurality of second regions 66. As shown in FIGS. 5 and 6, the first regions 64 are substantially planar regions. That is, the material within the first region 64 is in substantially the same condition before and after the formation step undergone by web material 60. The second regions 66 include a plurality of continuous, interconnected, rib-like deformations 74 which extend alternately beyond the plane of both the first and second surfaces (64A and

* = Trade-mark

64B, respectively) of the first region 64. In other embodiments, the deformations 74 may extend beyond the plane of only one of the first 64A or the second 64B surfaces of the first region 64.

FIG. 5 shows that the web material 60 having the strainable network 62 formed therein has a longitudinal centerline (or axis), l, and a lateral centerline (or axis), t. In the sanitary napkin embodiment shown in FIG. 1, the longitudinal centerline, l, of the strainable network 62 is shown as being rectilinear and generally oriented in the transverse direction. However, the longitudinal centerline, l, is not limited to such a configuration and orientation. The longitudinal centerline, l, can be rectilinear, curvilinear, or partially rectilinear and partially curvilinear. The longitudinal centerline, l, of the strainable network 62 can also be oriented in other directions, if desired.

FIG. 5 shows that the first regions 64 of the strainable network 62 have a first axis 68 and a second axis 69, wherein the first axis 68 is preferably longer than the second axis 69. In the simplified embodiment shown, the first axis 68 of the first region 64 is substantially parallel to the longitudinal axis, l, of the web material 60 while the second axis 69 is substantially parallel to the transverse axis, t, of the web material 60. The second regions 66 of the strainable network 62 also have a first axis 70 and a second axis 71. The first axis 70 of the second region 66 is substantially parallel to the longitudinal axis l of the web material 60, while the second axis 71 is substantially parallel to the transverse axis t of the web material 60. In the version of the web material shown in FIGS. 5 and 6, the first regions 64 and the second regions 66 are substantially linear, extending continuously in a direction substantially parallel to the longitudinal axis l of the strainable web material. In other embodiments, the second regions 66 can be curvilinear, or partially rectilinear and partially curvilinear.

While the enhanced flexibility of the strainable network is of primary interest in forming the hinge 54, the strainable network also provides portions of the flaps 24 with a degree of extensibility. FIGS. 6-8 show the manner in which the web material 60 with a strainable network 62 formed therein may exhibit at least two significantly different stages of controlled resistive force to elongation when

subjected to an applied elongation in a direction parallel to a predetermined axis. The strainable network 62 exhibits first resistive forces to the applied elongation (which develop between the stage shown in FIG. 6 and the stage shown in FIG. 7). The first resistive forces occur until the elongation of the web is sufficient to cause a substantial portion of the second regions 66 to enter the plane of applied elongation, as shown in FIG. 7. After the web material 60 reaches the stage shown in FIG. 7, it exhibits second resistive forces to further elongation (as illustrated by FIG. 8). Typically, when used in regions of the sanitary napkin 20 described herein, the web material will be within the first stage of resistance to elongation so the various portions of the strainable network 62 will only extend to the stage shown in FIG. 7 and adjust so as to relax back to the stage shown in FIG. 6.

The hinge 54 is created by forming the strainable network 62 into the desired portion of the sanitary napkin 20. As used herein, the term "forming" refers to the creation of a desired structure or geometry upon a web material or laminate that will substantially retain the desired structure or geometry when it is not subjected to any externally applied elongations or forces. Suitable methods for forming a strainable network into a web material include, but are not limited to embossing by mating plates or rolls, thermoforming, high pressure hydraulic forming, and casting.

The portion of the sanitary napkin 20 into which the strainable network 62 is formed can comprise a base material (or laminate) that has a relatively low extensibility under the forces that the sanitary napkin is normally subjected to when worn. When the strainable network 62 is formed therein, however, the base material can be made extensible under pre-selected forces such as those that the sanitary napkin is normally subjected to when worn.

The depth and number of deformations 74 in the strainable network 62 can be varied to control the applied force or elongation required to extend the material in the hinge regions 54 of the sanitary napkin 20. In one embodiment, the deformations 74 may be formed by two rigid plates having a pattern of meshing teeth. The outer dimensions of the pattern of teeth covers a surface area of the plates that is about 7.9" by 1.6" (20 cm by 4 cm) for each flap. On one surface of each plate are a series of teeth which are substantially triangular in cross section and taper

to a radiused vertex. The teeth in this embodiment preferably have a height of 3.175 mm, and are evenly spaced with the centerlines of the teeth spaced apart at 0.075" (1.9 mm) increments. On the "toothed" side of one plate, a series of grooves (preferably three grooves to construct the embodiment shown in FIG. 1) are cut which are parallel to each other and perpendicular to the evenly spaced teeth. These grooves correspond to the undeformed regions of the base material.

The preferred base material is placed between the plates in a hydraulic press having platens larger than the plates to evenly distribute pressure. The plates are compressed so that the teeth only partially engage (or mesh). Preferably, the plates are moved so that the teeth on the opposite plates are pressed toward each other about 80% of the distance toward full engagement (the point where the teeth would otherwise touch). Typically, in order to do this, when the base material comprises a laminate of apertured formed film and polyethylene backsheet material laminated together by adhesives that is described in conjunction with the embodiment shown in FIGS. 1-3, the plates will be compressed under a load of between about 25 - 70 psi. (about 1,750-4,900 g/cm²). The formed web material is then removed from between the plates. In the embodiment shown in FIGS. 1-3, the formed web material is provided with about 75% extensibility. The available stretch or elongation is increased if for a given number of deformations, the height or degree of deformation imparted to the web material is increased. Similarly, the available stretch or elongation is increased if for a given height or degree of deformation, the number or frequency of deformations is increased. The mating plates can be configured to create any of the patterns for the hinge 54 on the sanitary napkins shown in the drawings.

The sanitary napkin also has zones of extensibility 56 for relieving the stresses that develop in the flaps when they are folded down and under a wearer's undergarment. The terms "zone of extensibility" or "zone of differential extensibility", as used herein, refer to a portion of the sanitary napkin 20 which is capable of extending (and are preferably capable of extending a greater amount than surrounding portions of the sanitary napkin 20). The sanitary napkin 20 preferably has at least one zone of extensibility 56 for each flap 24, and more preferably has four zones of extensibility 56, one in each quarter of the sanitary napkin 20. Since

the zones of differential extensibility 50 relieve stresses in the flaps, they may be referred to herein as a type of "stress relief means".

The zones of extensibility 56 can be extensible in any desired direction, or in more than one direction. However, the zones of extensibility 56 are preferably primarily extensible generally outward in the transverse direction. This is generally in the direction of the arrows shown in Figure 1. As used herein, "generally in the transverse direction" means that the extensibility has a transverse component. All of the extension, however, need not be exactly parallel to the principal transverse centerline of the sanitary napkin. The extensibility, however, is preferably oriented more in the transverse direction than in the longitudinal direction.

The zones of extensibility 56 can comprise any structure capable of extending in the transverse direction (or in any other direction desired). The extensibility referred to herein, however, should be elasticless. That is, it should be accomplished without the use of separate elastic pieces, strands, or materials to contract one or more portions of the sanitary napkin. The zones of extensibility must also be accomplished without slitting or notching portions of the sanitary napkin that cover the wearer's undergarments. The zones of extensibility 56, therefore, comprise continuous material. This will have the advantage that exudates will not be able to travel through the slits or notches to soil the wearer's undergarments.

Suitable structures for the zones of extensibility 56 include, but are not limited to zones of material that are mechanically strained, corrugated, "ring rolled", formed with a strainable network therein, formed with a network of corrugations without any less extensible bands therein, folded, pleated, or joined along a curved juncture. These structures (although shown only as being part of the flaps 24), can comprise portions of the main body portion 22, portions of the flaps 24, or both. They can be integral parts of these components of the sanitary napkin, or separate elements, such as pieces of material, joined to the sanitary napkin. Suitable structures for the zones of extensibility are described in greater detail in U.S. Patent 5,389,094 issued to Lavash, et al. on February 14, 1995.

In the embodiment shown in FIG. 1, the zones of extensibility 56 can either comprise ring rolled regions of the flaps or a network of corrugations without any less extensible bands therein. In either case, the zones of extensibility 56 preferably have corrugations with ridges that are oriented generally in the longitudinal direction so that the zones of extensibility will be extensible primarily in the transverse direction.

There are many possible arrangements and configurations that the zones of extensibility 56 may have relative to each other and relative to the hinges 54. The zones of extensibility 56 (or at least portions thereof) are preferably spaced longitudinally away from the flap transverse centerline T1. As shown in FIG. 1, the portions of the zones of extensibility 56 that are spaced laterally furthest outward from the juncture 52 of the flaps 24 with the main body portion 22 are separated by an intermediate region 58. The portions of the zones of extensibility 56 that are closest to the juncture 52 of the flaps 24 with the main body portion 22 can also be spaced longitudinally away from the flap transverse centerline T1 so that they do not abut each other. Alternatively, these portions of the zones of extensibility 56 can abut each other.

The intermediate region 58 comprises a region of the flap 24 that includes the flap transverse centerline T1 and laterally adjacent regions. The intermediate region 58 is preferably stiffer than the regions of the sanitary napkin that comprise the hinge 54 and the zones of extensibility 56. This provides the flaps 24 with more integrity so that they will be easier for the user to handle. Thus, the main body portion 22 of the sanitary napkin is preferably the stiffest portion of the sanitary napkin. The intermediate region 58 is preferably the stiffest portion of the flaps 24, and is preferably not as stiff as the main body portion 22. The hinge 54 is preferably more flexible than either of those portions of the sanitary napkin.

The zones of extensibility 56 can be spaced away from the hinge 54, or be adjacent to the hinge 54. Preferably, as shown in Figure 1, the hinge 54 is contiguous (that is, touching or connected throughout in an unbroken sequence) with the zones of extensibility 56. The hinge 54 and the preferred ring rolled zones of extensibility 56 are, thus, portions of a continuous composite deformed region. As

shown in FIG. 1, the hinge 54 gradually transitions into portions of the sanitary napkin that comprise the zones of extensibility 56. The composite deformed region, thus, comprises continuous corrugations having ridges that are generally oriented in the longitudinal direction with a plurality of inextensible bands 64 in the center region adjacent the flap transverse centerline T1.

As shown in FIG. 1, the composite deformed region preferably has a proximal boundary along the juncture 52 of the flaps 24 with the main body portion 22 that is concave relative to the distal edges 46 of the flaps 24. The composite deformed region preferably has a distal boundary that is also concave relative to the distal edges 46 of the flaps. FIG. 1 shows that the distal boundary of the composite deformed region defines the boundary of the intermediate region 58 as a generally semi-circular area. Further, as shown in FIG. 1, the radius of curvature of the distal boundary of the composite deformed region is preferably less than the radius of curvature of the proximal edge of the composite deformed region. This is believed to provide the flaps 24 with a smooth fold line 19 around the sides of the crotch of the wearer's panties when the sanitary napkin 20 is in place therein (as shown in FIG. 4).

Many variations of the embodiments described herein are possible. For example, instead of comprising corrugations with linear ridges that are oriented in the longitudinal direction, the deformations forming these regions can be arranged in the form of a series of concentric concave ridges and valleys that are aligned with the boundaries of these regions. In another example, instead of being a contiguous composite deformed region, the hinge 54 and the zones of extensibility 56 may be separate spaced apart structures. Alternatively, the hinge 54 and/or the zones of extensibility 56, instead of comprising deformed regions of the sanitary napkin, can comprise some other suitable type of structure that provides the sanitary napkin with the desired properties of increased flexibility and extensibility in these regions. The main body portion 22 of the sanitary napkin 20 can also comprise a pair of embossed channels as described in U.S. Patent 5,308,346 issued to Sneller, et al. The features shown and described herein for the various embodiments can also be combined in any other suitable ways to form still more alternative embodiments.

The garment surface 20B of the sanitary napkin 20 may include, and preferably does include, fasteners for attaching the sanitary napkin to the wearer's undergarment. Figure 1 shows the central pad fastener 80 which is adapted to secure the main body portion 22 of the sanitary napkin to the crotch region of an undergarment. Any types of fasteners known in the art, such as adhesive fasteners and mechanical fasteners can be used. Fasteners comprising adhesives have been found to work well for this purpose, with pressure-sensitive adhesives being preferred. Fig. 1 shows a preferred arrangement which utilizes a pair of spaced apart longitudinally-oriented strips or zones of adhesive 80 that are centered about the longitudinal centerline L.

The outer surface of the flaps 24, adjacent the distal edges 46 of the flaps, is preferably provided with a flap adhesive 82. The flap adhesive 82 is used to assist in maintaining the flaps 24 in position after they are wrapped around the edge of the crotch portion of the panty. Suitable adhesive fasteners are described in greater detail in U.S. Patent 4,917,697. The flaps 24 can be maintained in position by attaching the flaps 24 to the undergarment, or to the opposing flap.

The fasteners used with the present invention are not limited to adhesive attachment means. Any type of fastener used in the art can be used for such purpose. For example, the sanitary napkin 20 could be secured to the wearer's undergarment by mechanical fasteners, such as VELCRO^{*}, or the fasteners described in U.S. Patent 4,946,527 entitled "Pressure-Sensitive Adhesive Fastener and Method of Making the Same" issued to Battrell on August 7, 1990, or U.S. Patent 5,392,498 entitled "Non-Abrasive Skin Friendly Mechanical Fastening System" issued to Goulait, et al. on February 28, 1995. For simplicity, however, the fasteners will be described in terms of adhesive attachment means.

The adhesive attachment means are respectively covered by removable release liners, central pad release liner and flap release liner, both designated 84. The pressure-sensitive adhesives should be covered with release liners 84 to keep the adhesives from sticking to extraneous surfaces prior to use. Suitable release liners are described in U.S. Patent 4,917,697. A particularly preferred release liner which also serves as an individual package for wrapping the sanitary napkin is described in

* = Trade-mark

U.S. Patent 4,556,146 issued to Swanson, et al. In other embodiments, the flaps 24 could be folded and tucked as described in U.S. Patent 5,281,209 issued to Osborn, et al. on January 25, 1994. The adhesive attachment means on such flaps could, instead of being covered with a release liner, be releasably adhered to a release surface provided on some other portion of the sanitary napkin, including the main body portion, or the flaps, or a separate component attached to the main body portion or the flaps.

The sanitary napkin 20 of the present invention is utilized by removing the release liners 84 and placing the sanitary napkin 20 in a panty 11 as shown in FIG. 4. The main body portion 22 is placed in the crotch portion of the panty with one end of the main body portion 22 extending towards the front section of the panty and the other end towards the back section of the panty. The backsheet 40 is placed in contact with the inner surface of the center of the crotch portion of the panty. The central pad adhesive fastener 80 maintains main body portion 22 in position. The distal portions of the flaps 24 are folded around the side edges 16 of the panty. The flap adhesives 82 secure the flaps 24 to the underside of the panty or to the opposing flap.

Other embodiments of the absorbent articles are also possible. For example, in alternative embodiments, instead of being provided with flaps, the absorbent article could be provided with undergarment covering components or ("side wrapping elements") that have a smaller span than conventionally sized flaps and that do not have to be manipulated by the wearer when placed in the wearer's undergarments. Absorbent articles having side wrapping elements are described in U.S. Patent No. 5,584,829 entitled "Absorbent Articles Having Panty Covering Components That Naturally Wrap the Sides of Panties" filed July 22, 1993, in the name of Lavash, et al. (PCT Publication No. WO 94/02096, published February 3, 1994); PCT Publication No. WO 95/07675, published March 23, 1995; and U.S. Patent No. 5,558,663 entitled "Absorbent Articles Having Undergarment Covering Components With Zones of Extensibility"

filed July 20, 1994 in the name of Weinberger, et al. (PCT Publication No. WO 95/03025, published February 2, 1995).

While particular embodiments of the present invention have been illustrated and described, it would be obvious to those skilled in the art that various other changes and modifications can be made without departing from the spirit and scope of the invention.

THE EMBODIMENTS OF THE INVENTION IN WHICH AN EXCLUSIVE PROPERTY OR PRIVILEGE IS CLAIMED ARE DEFINED AS FOLLOWS:

1. An absorbent article for wearing a crotch region of an undergarment, said crotch region having a pair of side edges, said absorbent article having a liquid pervious body-facing side, a liquid impervious garment side, a principal longitudinal centerline extending in a longitudinal direction, and a principal transverse centerline extending in a transverse direction, said absorbent article comprising:

a main body portion having a central region, two spaced apart longitudinal side edges and two spaced apart end edges, said main body portion comprising an absorbent core positioned between said body-facing side and said garment side;

a pair of flaps for folding around the side edges of the crotch region of undergarment, said flaps being joined to said main body portion, each flap extending laterally outward along one of the longitudinal side edges to a distal edge, said flaps each having a flap transverse centerline that passes through said central region of said main body portion;

a deformed region comprising a portion of said absorbent article that has planar portions and at least some portions that are displaced in a direction perpendicular to said planar portions, wherein said deformed region is substantially free of overlapping portions, and said deformed region forms a hinge between said main body portion and said flaps; and

at least one zone of extensibility comprising at least a portion of at least one of said flaps, wherein at least a portion of said zone of extensibility is spaced longitudinally away from said flap transverse

centerline,

wherein said deformed hinge region and said at least one zone of extensibility are contiguous and form a composite region, said composite region having a proximal boundary which is concave relative to the distal edge of said flap and a distal boundary which is also concave relative to the distal edge of said flap, and said distal boundary has a lesser radius of curvature than said proximal boundary of said composite region, and

wherein the portion of said flaps outboard of said distal boundary of said composite region is a generally semi-circular area that is undeformed and stiffer than said composite region.

2. The absorbent article of Claim 1 wherein said deformed region forming said hinge comprises at least one corrugation.
3. The absorbent article of Claim 2 wherein said deformed region forming said hinge comprises a plurality of corrugations.
4. The absorbent article of Claim 2 wherein said at least one corrugation comprises a ridge that is generally oriented in the longitudinal direction.
5. The absorbent article of Claim 1 wherein at least a portion of said deformed region forming said hinge comprises a portion of said absorbent article which has a strainable network formed therein, said strainable network comprising at least two visually distinct regions wherein at least one of said regions has a surface-pathlength that is greater than that of the other region, wherein the regions exhibiting the longer surface-pathlength comprise one or more rib-like elements and the regions with the shorter surface-pathlength are preferably substantially planar.

6. The absorbent article of Claim 5 wherein said portion of said deformed region having a strainable network formed therein is located in a region of said absorbent article that said flap transverse centerline passes through.
7. The absorbent article of Claim 5 wherein said rib-like elements are generally oriented in the longitudinal direction.
8. The absorbent article of Claim 1 wherein said zone of extensibility comprises a region having a plurality corrugations therein.
9. The absorbent article of Claim 7 wherein said corrugations comprise ridges that are generally oriented in the longitudinal direction.
10. The absorbent article of Claim 8 wherein said zone of extensibility is extensible generally in the transverse direction.
11. The absorbent article of Claim 1 wherein each flap comprises two contiguous zones of extensibility.
12. The absorbent article of Claim 1 wherein said hinge has a proximal boundary which is concave relative to the distal edge of said flap.
13. The absorbent article of Claim 12 wherein said hinge has a distal boundary which is also concave relative to the distal edge of said flap.
14. The absorbent article of Claim 1 wherein said generally semi-circular portion of said flaps has a fastener thereon.
15. The absorbent article of Claim 1 wherein said flaps are integral with said main body portion.

16. The absorbent article of Claim 1 wherein said flaps comprise separate components that are joined to said main body portion.

17. An absorbent article having a liquid pervious body-facing side, a liquid impervious garment side, a principal longitudinal centerline extending in a longitudinal direction, and a principal transverse centerline extending in a transverse direction, said absorbent article comprising:

a main body portion having a central region, two spaced apart longitudinal side edges and two spaced apart end edges, said main body portion comprising an absorbent core positioned between said body-facing side and said garment side;

a pair of flaps joined to said main body portion, each flap extending laterally outward along one of the longitudinal side edges to a distal edge, said flaps each having a flap transverse centerline that passes through said central region of said main body portion and points along said flap transverse centerline;

a deformed region comprising a portion of said absorbent article that forms a hinge between said main body portion and at least a portion of said flaps, wherein said deformed region comprises a plurality of corrugations and said corrugations comprise ridges that are generally oriented in the longitudinal direction, and said hinge has a proximal boundary which is concave relative to the distal edge of said flaps; and

a zone of extensibility comprising at least a portion of at least one of said flaps, wherein at least a portion of said zone of extensibility is spaced longitudinally away from said flap transverse centerline and said zone of extensibility comprises a plurality of corrugations, at least some of which are contiguous with said corrugations forming said hinge.

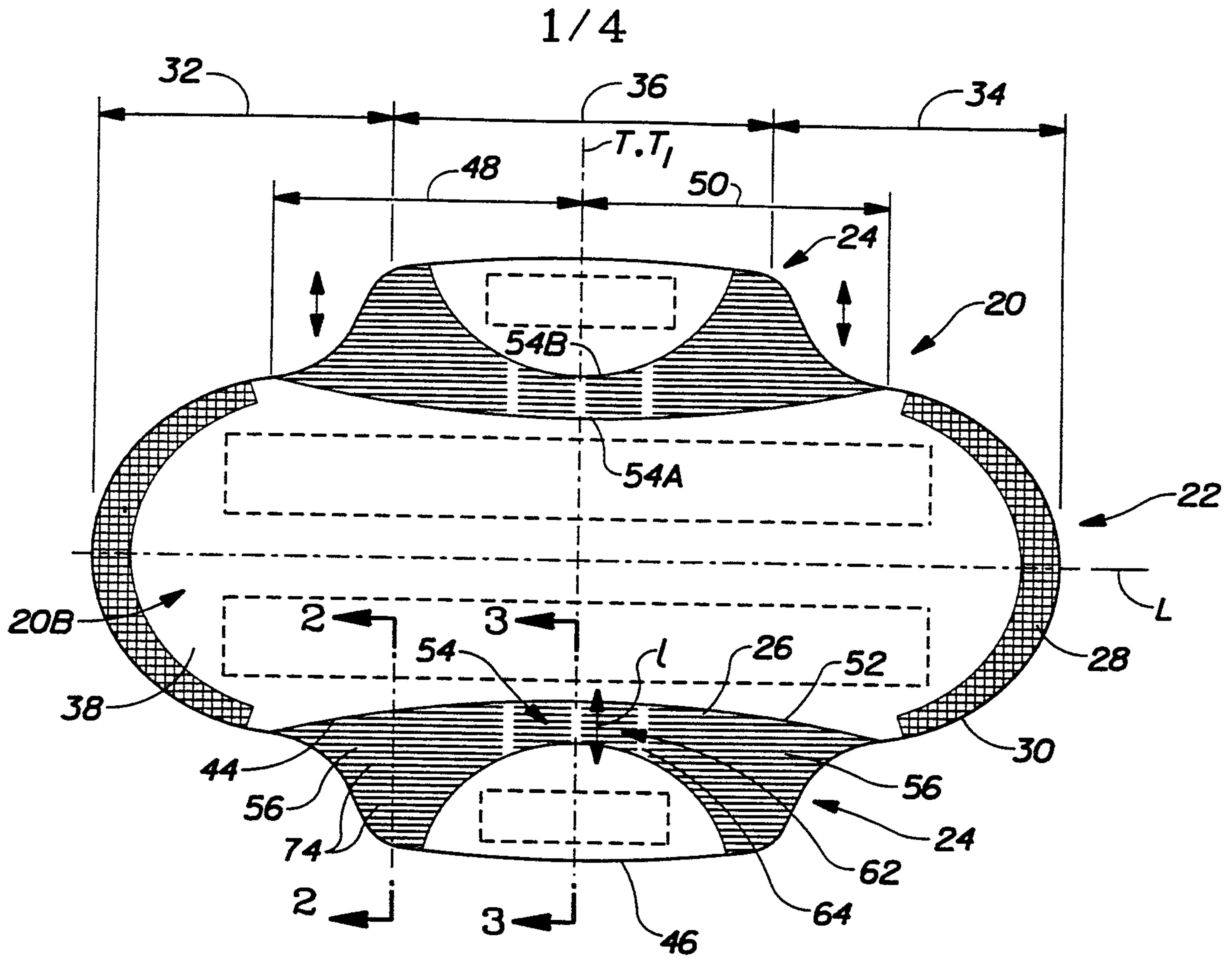

Fig. 1

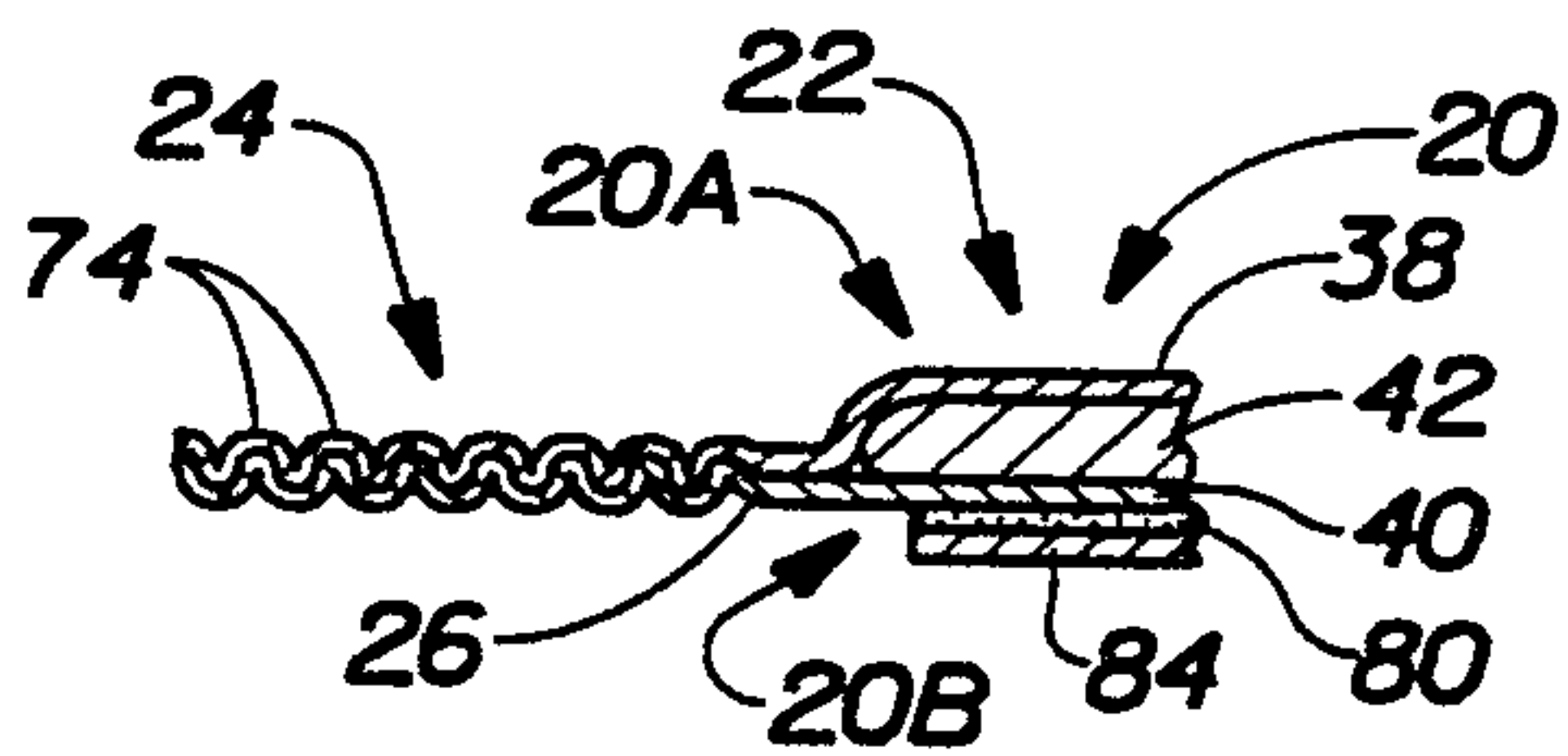

Fig. 2

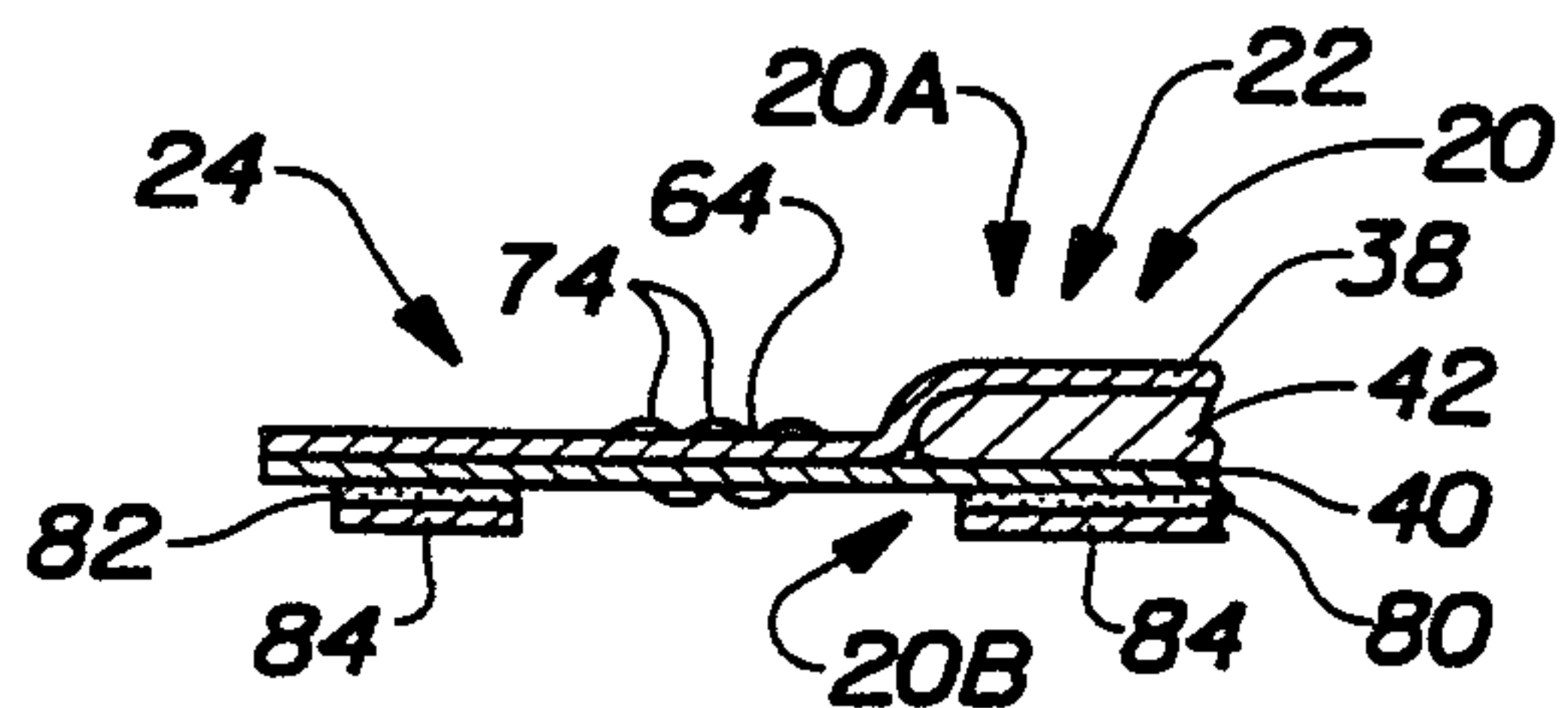

Fig. 3

2/4

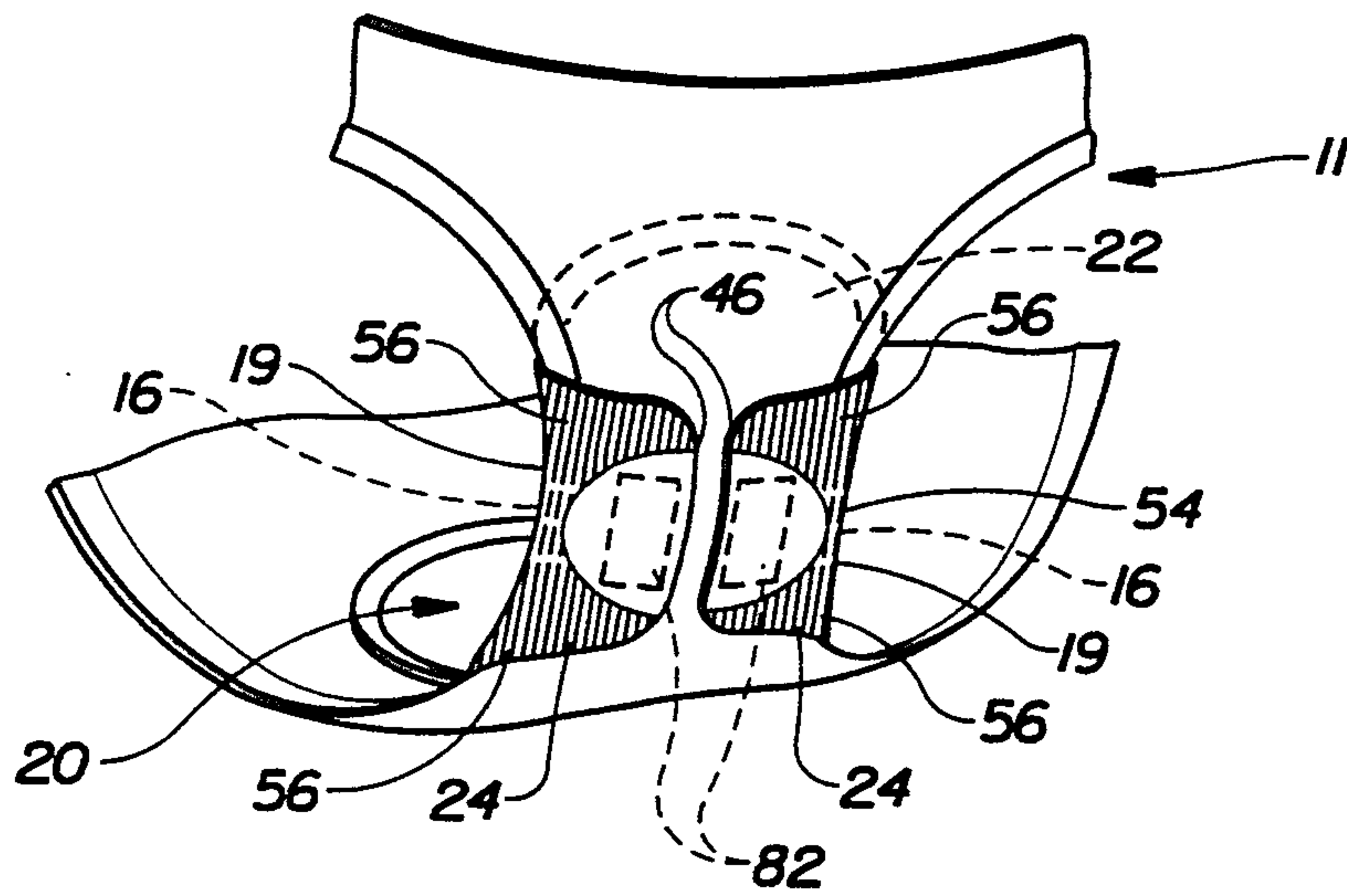

Fig. 4

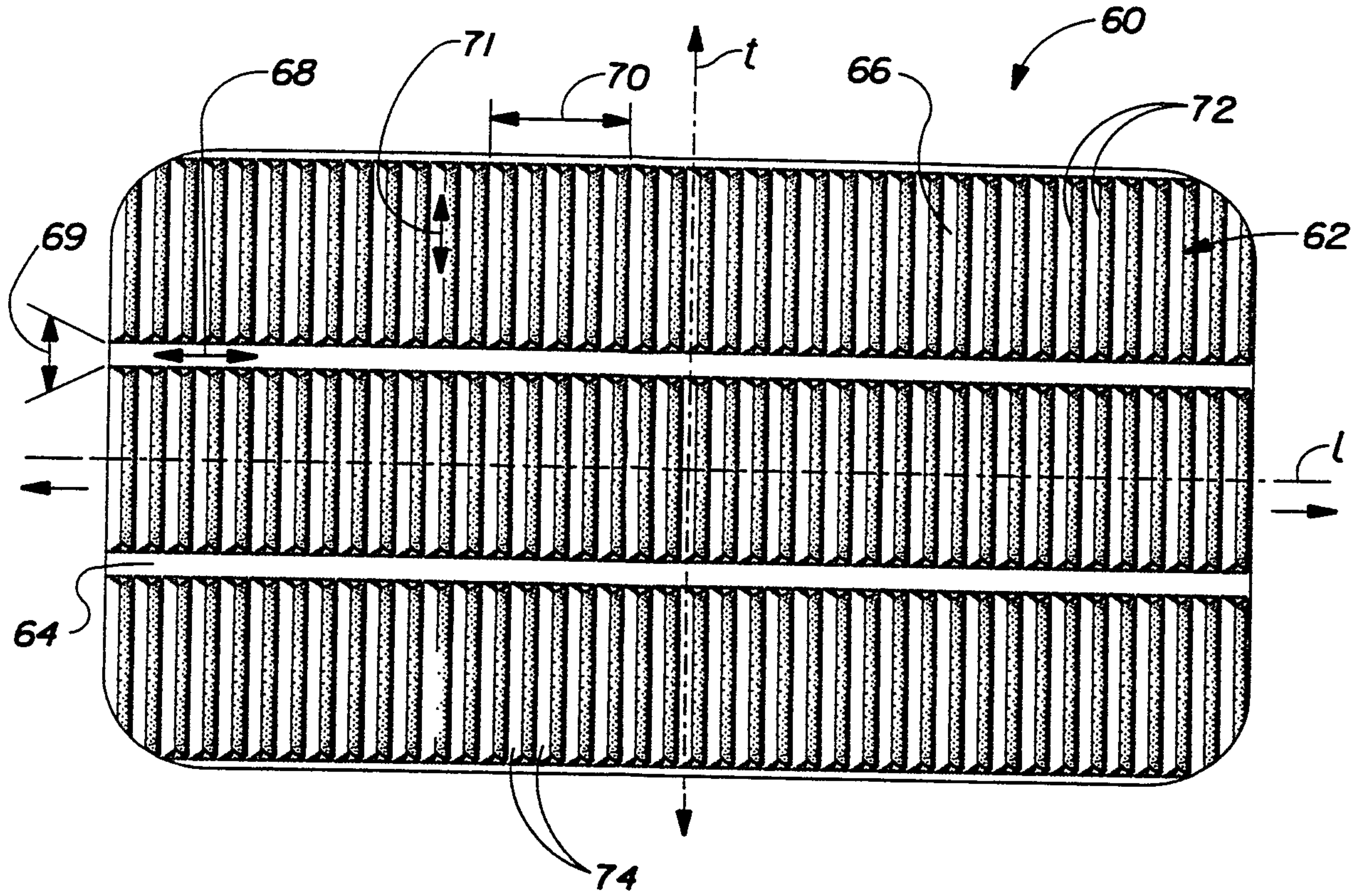

Fig. 5

4/4

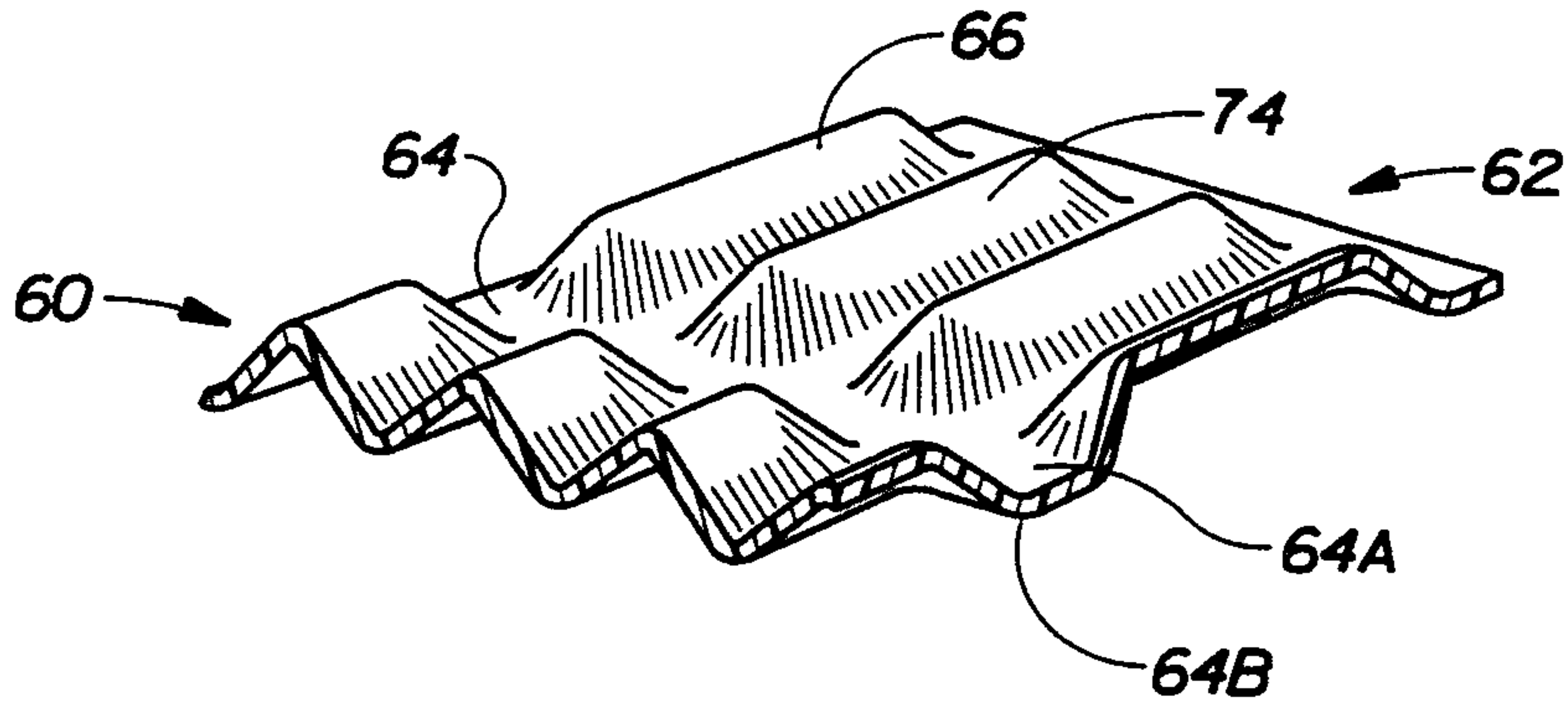

Fig. 6

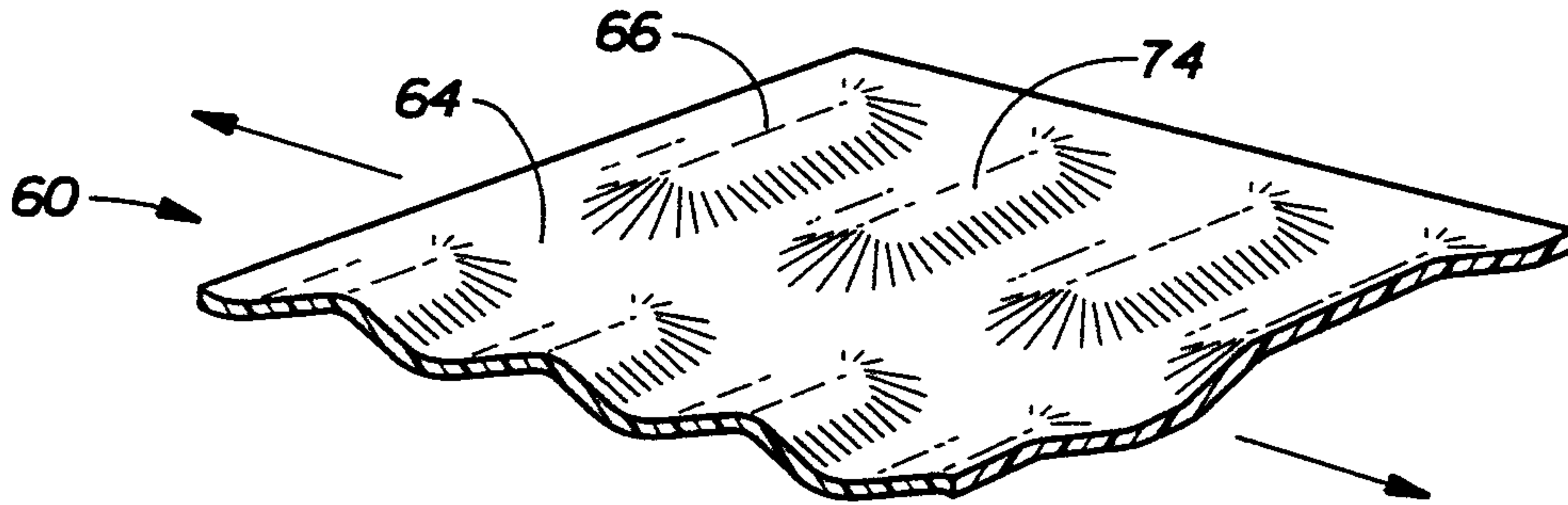

Fig. 7

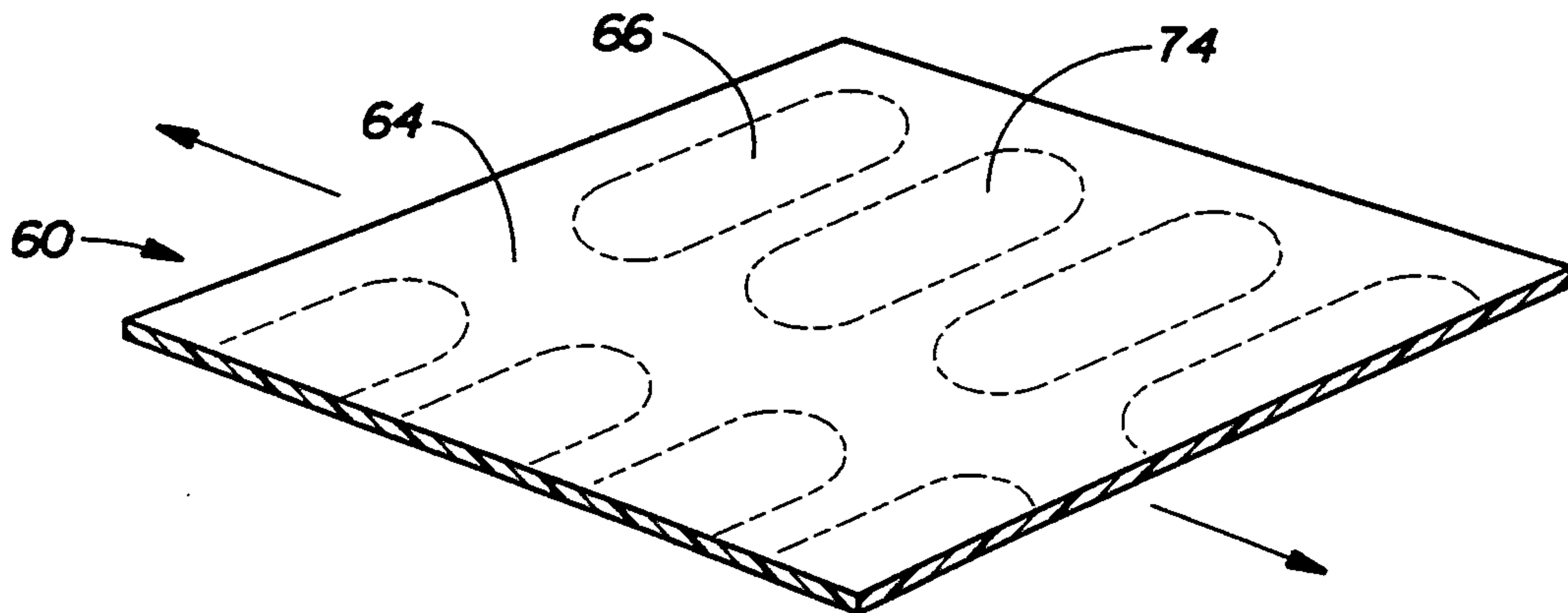

Fig. 8

