

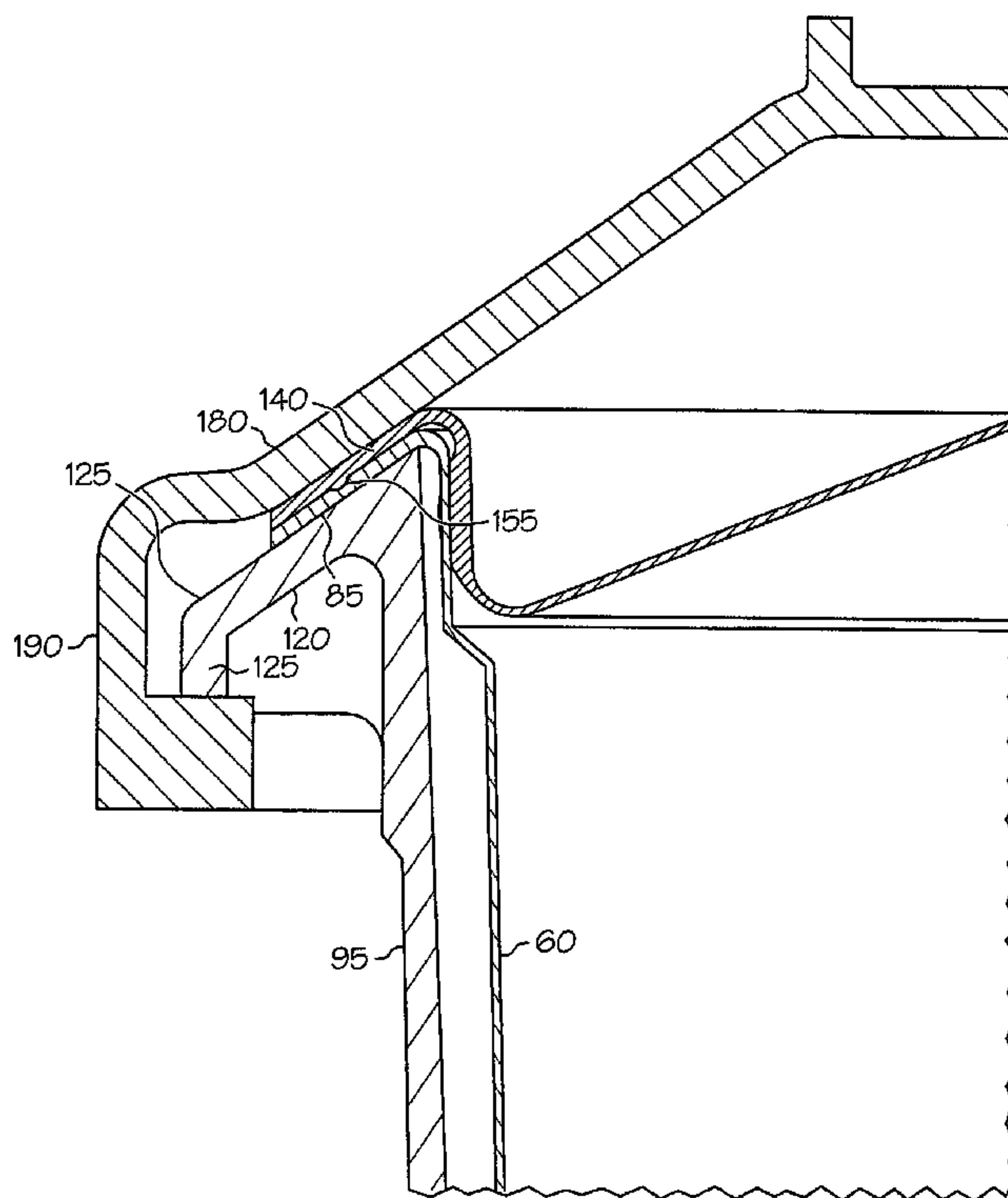

(86) Date de dépôt PCT/PCT Filing Date: 2004/11/23
 (87) Date publication PCT/PCT Publication Date: 2005/08/18
 (85) Entrée phase nationale/National Entry: 2006/06/23
 (86) N° demande PCT/PCT Application No.: US 2004/039493
 (87) N° publication PCT/PCT Publication No.: 2005/075096
 (30) Priorité/Priority: 2004/01/16 (US10/759,352)

(51) Cl.Int./Int.Cl. *B05B 7/24* (2006.01)
 (71) Demandeur/Applicant:
ILLINOIS TOOL WORKS INC., US
 (72) Inventeurs/Inventors:
KOSMYNA, MICHAEL J., US;
WISNIEWSKI, RALPH A., US
 (74) Agent: FINLAYSON & SINGLEHURST

(54) Titre : ENSEMBLE ALIMENTATION EN FLUIDE POUR PISTOLET DE PULVERISATION DOTE D'UN GODET ET D'UN COUVERCLE PRESENTANT DES COLLERETTES D'APPARIEMENT
 (54) Title: FLUID SUPPLY ASSEMBLY FOR SPRAY GUNS WITH CUP AND LID COMPRISING MATING FLANGES



(57) **Abrégé/Abstract:**

A fluid supply assembly. The fluid supply assembly includes a disposable cup and lid, and a reusable cup holder all comprising mating flanges and an outer lid comprising a frustoconical inner surface mating with the flanges.

(12) INTERNATIONAL APPLICATION PUBLISHED UNDER THE PATENT COOPERATION TREATY (PCT)

(19) World Intellectual Property
Organization
International Bureau



(43) International Publication Date
18 August 2005 (18.08.2005)

PCT

(10) International Publication Number
WO 2005/075096 A1

(51) International Patent Classification⁷: **B05B 7/24**

Michael, J. [US/US]; 2442 Shoreland Avenue, Toledo, OH 43611 (US). WISNIEWSKI, Ralph, A. [US/US]; 2291 Fitkin Street, Toledo, OH 43613 (US).

(21) International Application Number:
PCT/US2004/039493

(74) Agent: SOLITS, Lisa, M.; Illinois Tool Works, Inc., 3600 West Lake Avenue, Glenview, IL 60026 (US).

(22) International Filing Date:
23 November 2004 (23.11.2004)

(81) Designated States (unless otherwise indicated, for every kind of national protection available): AE, AG, AL, AM, AT, AU, AZ, BA, BB, BG, BR, BW, BY, BZ, CA, CH, CN, CO, CR, CU, CZ, DE, DK, DM, DZ, EC, EE, EG, ES, FI, GB, GD, GE, GH, GM, HR, HU, ID, IL, IN, IS, JP, KE, KG, KP, KR, KZ, LC, LK, LR, LS, LT, LU, LV, MA, MD, MG, MK, MN, MW, MX, MZ, NA, NI, NO, NZ, OM, PG, PH, PL, PT, RO, RU, SC, SD, SE, SG, SK, SL, SY, TJ, TM, TN, TR, TT, TZ, UA, UG, US, UZ, VC, VN, YU, ZA, ZM, ZW.

(25) Filing Language: English

(26) Publication Language: English

(30) Priority Data:
10/759,352 16 January 2004 (16.01.2004) US

(71) Applicant (for all designated States except US): ILLINOIS TOOL WORKS, INC. [US/US]; 3600 West Lake Avenue, Glenview, IL 60026 (US).

(84) Designated States (unless otherwise indicated, for every kind of regional protection available): ARIPO (BW, GH, GM, KE, LS, MW, MZ, NA, SD, SL, SZ, TZ, UG, ZM, ZW), Eurasian (AM, AZ, BY, KG, KZ, MD, RU, TJ, TM),

(72) Inventors; and

(75) Inventors/Applicants (for US only): KOSMYNA,

[Continued on next page]

(54) Title: FLUID SUPPLY ASSEMBLY FOR SPRAY GUNS WITH CUP AND LID COMOPRISING MATING FLANGES

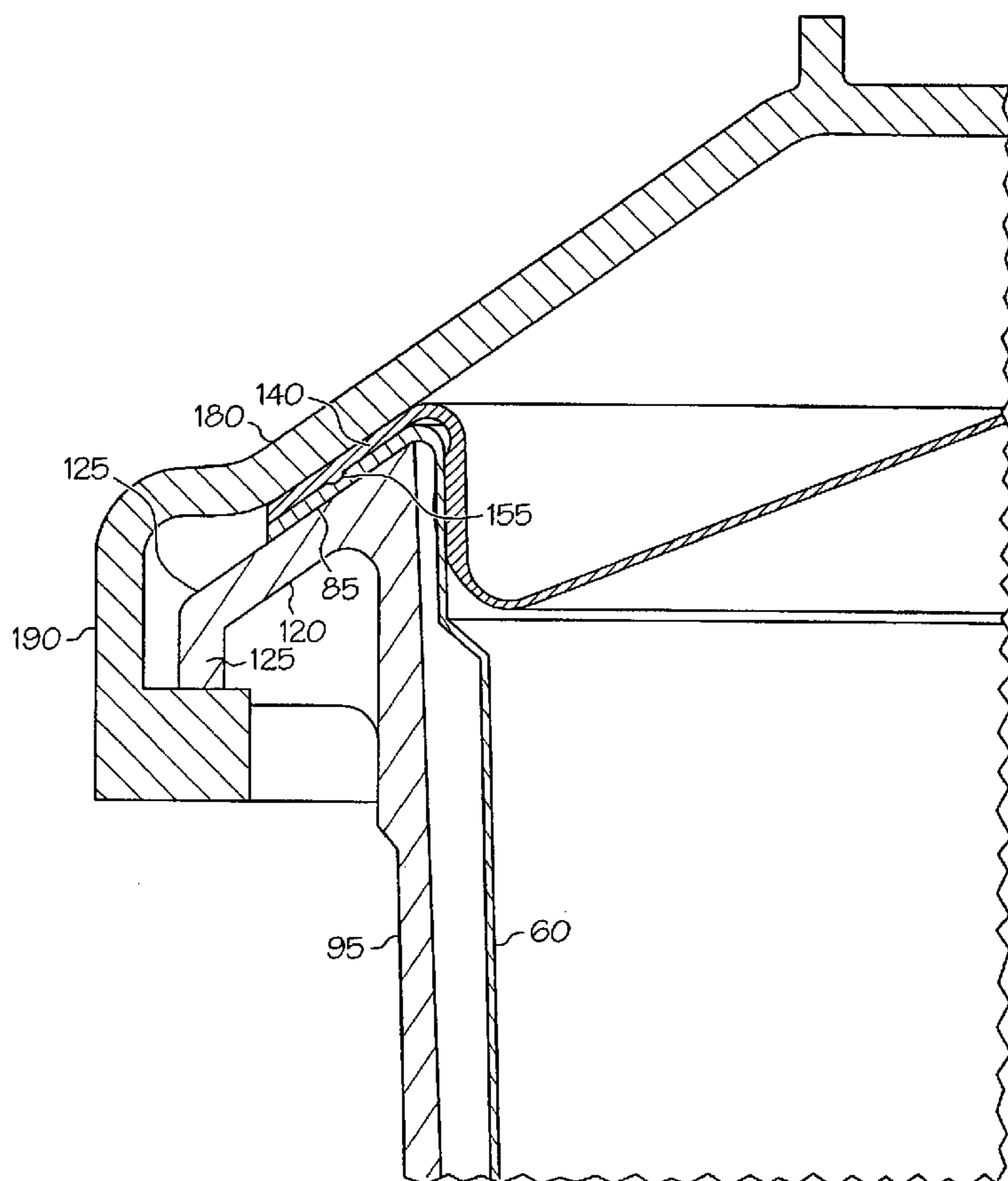

(57) Abstract: A fluid supply assembly. The fluid supply assembly includes a disposable cup and lid, and a reusable cup holder all comprising mating flanges and an outer lid comprising a frustoconical inner surface mating with the flanges.

WO 2005/075096 A1

WO 2005/075096 A1



European (AT, BE, BG, CH, CY, CZ, DE, DK, EE, ES, FI, FR, GB, GR, HU, IE, IS, IT, LU, MC, NL, PL, PT, RO, SE, SI, SK, TR), OAPI (BF, BJ, CF, CG, CI, CM, GA, GN, GQ, GW, ML, MR, NE, SN, TD, TG).

For two-letter codes and other abbreviations, refer to the "Guidance Notes on Codes and Abbreviations" appearing at the beginning of each regular issue of the PCT Gazette.

Published:

— *with international search report*

FLUID SUPPLY ASSEMBLY FOR SPRAY GUNS WITH CUP AND LID COMOPRISING MATING FLANGES

BACKGROUND OF THE INVENTION

5 The present invention is directed generally to a fluid supply assembly for a fluid applicator, and more particularly to a fluid supply assembly with a disposable cup and lid, and a reusable cup holder and outer lid.

10 Some fluid applicators, such as gravity feed paint spray guns, have a fluid supply cup mounted on top of the fluid applicator. The fluid supply cup is typically reusable. Fluid, such as paint, is generally measured and mixed in a separate container, and then poured into the fluid supply cup for use. The container for measuring and mixing must be either cleaned or disposed of. During fluid application, the user must be careful not to tip the fluid applicator too much, or fluid will leak out a vent in the fluid supply cup. In
15 addition, the user cannot use all of the fluid because it moves around in the fluid supply cup and air can be drawn into the drain hole.

 Attempts have been made to provide fluid supply assemblies which do not leak during use. For example, U.S. Patent No. 5,582,350 describes a hand held spray gun with
20 a top mounted paint cup which extends from the rear of the gun body at an angle of $30^{\circ}\pm 10^{\circ}$. The paint can be sealed in a collapsible closed bag in the paint cup, eliminating the need for a vent. Using the closed bag, the gun can be operated at all angles without the paint leaking out of the vent in the paint cup. The use of the closed bag also allows more of the paint to be used. In addition, it reduces cleanup time and cost because the bag keeps
25 the paint cup clean. Thus, U.S. Patent No. 5,582,350 represented a significant advance in the art.

 U.S. Patent No. 6,588,681 describes a paint cup with an outer container and an inner liner. There is an indicating sheet with indicia for measuring the paint components
30 which must be positioned carefully between the inner liner and the outer container so that the indicia for measuring are aligned accurately. The paint cup includes a lid which is sealed to the outer container with an external sealing ring. An additional support ring is

required so that the paint cup can be used on a paint shaker machine. Moreover, the paint cup is unnecessarily complicated.

Therefore, there remains a need for a fluid supply assembly which provides an
5 improved seal to prevent fluid leakage.

SUMMARY OF THE INVENTION

The present invention meets this need by providing a fluid supply assembly. The
10 fluid supply assembly includes a disposable cup, a reusable cup holder, a disposable lid, and a reusable outer lid.

The disposable cup has a side wall, an open outlet end, and a closed bottom defining an interior, the outlet end defining an axis, and a flange extending outward and
15 downward from an edge of the outlet end of the disposable cup at an angle.

The reusable cup holder has a side wall, an open upper end, and a lower end, the lower end having an opening therein, the upper end defining an axis, a flange extending outward and downward from an edge of the upper end of the reusable cup holder, the
20 angle of the flange of the reusable cup holder being substantially the same as the angle of the flange of the disposable cup whereby the flange of the reusable cup holder supports the flange of the disposable cup, a connecting surface at the upper end, the reusable cup holder being adapted to receive the disposable cup.

The disposable lid has an inner portion and an outer portion, the outer portion
25 having an edge having a frustoconical angle, the angle of the edge of the disposable lid being substantially the same as the angle of the flange of the disposable cup, the disposable lid being adapted to fit over the disposable cup, the edge of the disposable lid mating with the flange of the disposable cup, the disposable lid having a fitting integrally
30 connected to the inner portion, the fitting having an opening therethrough.

The reusable outer lid has an inner portion and a outer portion, the outer portion having an edge having a frustoconical angle, the angle of the edge of the reusable outer lid

being substantially the same as the angle of the flange of the reusable cup holder, the reusable outer lid being adapted to fit over the reusable cup holder, the edge of the reusable outer lid mating with the flange of the reusable cup holder, the reusable outer lid having a fitting integrally connected to the inner portion, the fitting of the reusable outer lid having an opening therethrough, the fitting of the disposable lid adapted to fit into the fitting of the reusable outer lid, a complementary connecting surface at the edge of the reusable outer lid, the complementary connecting surface of the reusable outer lid adapted to mate with the connecting surface of the reusable cup holder to seal the reusable cup holder and reusable outer lid together.

10

BRIEF DESCRIPTION OF THE DRAWINGS

Fig. 1 is side elevation view of a gravity-feed paint sprayer with a fluid supply assembly according to the present invention.

15

Fig. 2 is an exploded side sectional view of one embodiment of a fluid supply assembly according to the present invention.

20

Fig. 3 is partial side sectional view of the assembled connection between the reusable cup holder and reusable outer lid of the present invention.

Fig. 4 is a partial side sectional view of an alternate embodiment of the reusable outer lid showing stacking of the fluid supply assemblies of the present invention.

25

Fig. 5 is a side sectional view of an alternate embodiment of the disposable lid of the present invention.

Fig. 6 is an assembled side sectional view of the alternate embodiment of the disposable lid of Fig. 5 and the disposable cup.

30

Fig. 7 is a side sectional view of an alternate embodiment of the disposable cup of the present invention.

Fig. 8 is a top view of an alternate embodiment of the disposable cup of the present invention.

Fig. 9 is a side sectional view of the disposable cup of Fig. 8 in one axis.

5

Fig. 10 is a side sectional view of the disposable cup of Fig. 8 in another axis.

Fig. 11 is a partial assembled side sectional view of the connection between one embodiment of an adapter useful in the present invention and the reusable outer lid of the present invention.

10

Fig. 12 is a top view of the adapter of Fig. 11.

Fig. 13 is a top view of the assembled connection of Fig. 11 before rotation (without the filter).

15

Fig. 14 is a perspective view of reusable outer lid.

Fig. 15 is a top view of the assembled connection of Fig. 11 after rotation (without the filter).

20

DETAILED DESCRIPTION OF THE INVENTION

A fluid supply assembly attached to a fluid applicator is shown in Fig. 1. In one embodiment, the fluid supply assembly is for feeding liquid, such as paint, to the fluid applicator, such as a paint sprayer. The present invention will be described for a paint sprayer, such as a gravity feed paint sprayer for use in applying paint to coat substrate surfaces. The paint sprayer can be used in the automotive refinishing market, such as automobile body shops, for repainting automobiles. Although the fluid supply assembly is described for a paint sprayer, it is not limited to such use. It can be used for supplying other flowable liquids, including, but not limited to, beverages, foods, condiments (such as ketchup), gasoline, petrochemicals and hydrocarbons, water, water-based solutions, solvent-based solutions, emulsions, adhesives, and the like.

30

Referring to Fig. 1, a paint sprayer 10 is shown. It includes a body 15, a nozzle assembly 20 secured to a front end 25 of body 15, and a handle 30 depending from a rear end 35 of body 15. A trigger 40 is pivotally secured to body 15 for the manual actuation of sprayer 10. A top-mounted paint supply assembly 45 is mounted to body 15 near front end 25 for feeding paint to nozzle assembly 20. An air connector 50 is connected to an air hose (not shown) for the delivery of pressurized air to nozzle assembly 20, wherein the delivery of pressurized air is controlled by trigger 40.

Compressed air from air connector 50 is delivered through an internal passage (not shown) to nozzle assembly 20 and the compressed air acts to atomize paint and deliver it through nozzle assembly 20 to spray paint about paint axis 55. Paint is delivered to nozzle assembly 20 from paint supply assembly 45.

Figs. 1-3 show a first embodiment of paint supply assembly 45 of the present invention. The paint supply assembly includes disposable cup 55. Disposable cup 55 has a side wall 60 which is generally cylindrical. The outlet end 65 at the top of the cup is open, and the bottom 70 is closed. The side wall 60, outlet end 65, and bottom 70 define an interior 75. The outlet end 65 defines an axis 80. There is a flange 85 extending outward and downward from the edge of the outlet end 65. The flange 85 extends downward at an angle α in a range of from about 10° to about 70° from the axis 80 of the outlet end 65.

The disposable cup 55 can be made of transparent or translucent plastic if desired. Suitable plastics include, but are not limited to, low density polyethylene. The disposable cup has flexible side walls which allow the disposable cup to collapse as paint is dispensed. The side walls can be thin, for example in the range of about 0.003 in. to about 0.008 in. The bottom can be slightly thicker, in the range of about 0.003 to about 0.02 in., so that the bottom will remain substantially flat as the side walls collapse, if desired. No air vent is needed in the disposable cup because the side walls collapse. This allows the user to discharge the paint sprayer at any angle without leaks and to use more of the paint in the cup than is possible with conventional gravity feed paint cups.

Reusable cup holder 90 is generally cylindrical. It has a side wall 95, an open upper end 100, and a lower end 105. The lower end 105 has an opening 110 in it. The opening 110 can cover all or almost all of the lower end 105, if desired. Alternatively, the lower end 105 could have one or more smaller openings. The opening 110 in the lower end 105 allows ambient air pressure to help the disposable cup collapse during use. Optionally, the reusable cup holder 90 can include one or more legs 112 extending downward from the lower end 105. The legs can extend all of the way around the opening 110 (i.e., a circular rib) or only a part of the way around the opening 110. The legs 112 can assist in stacking the fluid supply assemblies as described below.

10

The upper end 100 defines an axis 115. A flange 120 extends outward and downward from an edge of the upper end 100. The flange 120 extends downward at an angle β in a range of from about 10° to about 70° from the axis 115 of the upper end 100. The angle β is substantially the same as the angle α of the flange 85 of disposable cup 55. When the disposable cup 55 is placed in the reusable cup holder 90, the flange 120 of reusable cup holder 90 supports the flange 85 of the disposable cup 55.

15

There is a connecting surface 125 at the upper end 100 of the reusable cup holder 90. The connecting surface 125 can be on the sidewall, extend out from the side wall, or it can extend outward from the end of the flange 120, if desired.

20

The reusable cup holder 90 can be made of a rigid plastic, including, but not limited to, polypropylene or high density polyethylene. Desirably, the plastic selected is strong enough that the reusable cup holder can withstand the clamping force of a paint shaker machine. The plastic is desirably transparent or translucent, although it could be opaque. If an opaque plastic is used, the side wall should have elongated openings in it so that the disposable cup and its contents can be seen. Typically, the walls can be in the range of from about 0.02 in. to about 0.08 in. thick.

25

The disposable lid 130 has a generally frustoconical portion 135. The outer edge 140 of the generally frustoconical portion 135 defines an axis 145. The angle γ of the outer edge 140 of the generally frustoconical portion 135 is in a range of from about 10° to about 70° from the axis 145. The angle γ is substantially the same as the angle α of the

30

flange 85 of disposable cup 55. The disposable lid 130 fits over the disposable cup 55, and the edge 140 of the disposable lid 130 mates with the flange 85 of the disposable cup 55. The inside of the disposable lid 130 can have a downward extending rib 150, if desired. The downward extending rib 150 extends into the interior 75 of the disposable cup and mates with the inside of the side wall 60 of the disposable cup 55, forming a seal. Additionally, there can be a downwardly projecting sealing bead 155 on the inside of the disposable lid 130. The downwardly projecting sealing bead 155 mates with the flange 85 of the disposable cup 55 to aid in forming a seal.

10 There is a fitting 160 integrally connected to the generally frustoconical portion 135. The fitting 160 has an opening 165 extending through it.

The disposable lid 130 can be made of a transparent, translucent, or opaque plastic. Suitable plastics include, but are not limited to, polypropylene or high density polyethylene.

The reusable outer lid 170 has a generally frustoconical portion 175. The outer edge 180 of the generally frustoconical portion 175 defines an axis 185. The angle δ of the outer edge 180 of the generally frustoconical portion 175 is in a range of from about 10° to about 70° from the axis 185. The angle δ is substantially the same as the angle β of the flange 120 of reusable cup holder 90. The outer edge 180 of the reusable outer lid 170 mates with the flange 120 of the reusable cup holder 90. There is a complementary connecting surface 190 at the outer edge 180 of the reusable outer lid 170. In this embodiment, the complementary connecting surface 190 extends downward from the outer edge 180, although other arrangements are possible. The complementary connecting surface 190 mates with the connecting surface 125 of the reusable cup holder 90 to seal the reusable cup holder 90 and reusable outer lid 170 together.

The reusable outer lid has a fitting 195 integrally connected to the generally frustoconical portion 175. The fitting 195 has an opening 200 extending through it. The fitting 160 of the disposable lid 130 fits into the fitting 195 of the reusable outer lid 170.

The reusable outer lid 170 can be made of a strong, tough plastic. Desirably, the plastic selected is strong enough that the reusable outer lid can withstand the clamping force of a paint shaker machine. Examples of suitable plastic include, but are not limited to, acetal. Acetal is not typically transparent. The reusable outer lid 170 can include one or more sight holes so that the paint level is visible to the user, if desired. The sight hole can also allow the user to write the name of the name of the paint type on the disposable lid, and it permits easy removal of the disposable lid from the reusable outer lid.

A conduit 210 connects the fluid supply assembly to the paint sprayer 10. The conduit 210 mates with the fitting 195 of the reusable outer lid 170 and the fitting 160 of the disposable lid 130. The conduit 210 has an opening 215 through it. There is a path for fluid to flow from the interior 75 of the disposable cup 55 through the opening 165 in the disposable lid 130 through the opening 215 in conduit 210 to the paint sprayer 10. An optional filter 220 can be placed into the opening 215 in the conduit 210, the opening 200 in the reusable outer lid 170, or the opening 165 in the disposable lid 130 to filter out impurities.

In order to use the fluid supply assembly, the disposable cup 55 is placed into the reusable cup holder 90. The flange 85 of the disposable cup 55 mates with the flange 120 of the reusable cup holder 90. The flange 85 centers the disposable cup 55 in the reusable cup holder 90.

Optionally, there can be indicia 230 on either the disposable cup 55 or the reusable cup holder 90 or both. The indicia 230 can be molded in the side, printed on the side, a label can be attached to the side, or the indicia can be supplied in some other fashion. The indicia 230 can be used to measure paint components. Alternatively, the disposable cup and reusable cup holder can be used on a scale, or with a measuring stick to measure the paint components.

The indicia can include mixing scales with one or more mixing ratios, e.g., 4:1 mixing ratio, 2:1 mixing ratio; 3:2:1 mixing ratio, etc. Each mixing ratio might include one or more different sized divisions so that different amounts of fluid could be measured using each mixing ratio. The indicia can also include one or more universal scales, i.e.,

scales with equal sized divisions. One universal scale might have 20 equal divisions, another 10 equal divisions, a third 5 equal divisions. There can be as many universal scales as needed. The multiple universal scales allow the user to measure different amounts of fluid without using the mixing ratio scales, which would not have to be included. The user could select the appropriate universal scale based on the amount of fluid needed.

Alternatively, the measuring guide could have indicia printed on a clear, thin, flat, plastic sheet. The plastic sheet has connecting parts on opposite sides of the sheet, including, but not limited to, tabs and slots. The plastic sheet is formed into a cylinder, and the tabs are inserted into the slots. The measuring guide can be placed on the table, and the disposable cup, or the reusable cup holder with the disposable cup in it, can be placed inside the cylinder. After the paint components are measured, the disposable cup (and the reusable cup holder if present) is removed from the cylinder. This can be done by lifting the disposable cup by the flange, or by disconnecting the tabs and slots on the sheet. Optional removal tabs on the flange 180 degrees apart can assist in removing the disposable cup. The disposable cup can then be placed in the reusable cup holder (if not already there). This measuring guide improves visibility and accuracy in measuring the paint components. The rectangular shape is easy to manufacture. It eliminates the necessity for accurate placement of a label on the disposable cup or reusable cup holder. It also allows more direct viewing of the indicia than with the label (i.e., through the label, the reusable cup holder, and the disposable cup). It is particularly advantageous when a smaller diameter disposable cup is used because the indicia can be placed right next to the disposable cup. Finally, if the disposable cup is used alone, the reusable cup holder stays cleaner because it is not used when pouring and measuring paint.

The sheets may be formed in different sizes so that the measuring guides can be used with different sizes of disposable cups. A larger sheet could be used with the reusable cup holder and/or the larger disposable cup. The cylinder formed by the larger sheet is big enough so that the reusable cup holder and/or the larger disposable cup fit inside. The larger sheet could include a marking, such as a dotted line near the bottom, to allow proper alignment of the indicia depending whether the larger disposable cup is used with the reusable cup holder or not. The entire sheet might be used when the larger

disposable cup is used with a reusable cup holder having legs. When the larger disposable cup is used alone (or the reusable cup does not affect the alignment, e.g. because it does not have legs), the sheet could be cut at the marking. This allows proper alignment in either situation. A smaller sheet could be used when a smaller disposable cup is used.

- 5 The reusable cup holder would not generally be used with the smaller disposable cup when measuring fluid in order to provide proper alignment of the indicia and the smaller disposable cup.

10 After the disposable cup 55 is filled with paint, the disposable lid 130 is placed on top of the disposable cup 55. The angle γ of the edge 140 of disposable lid 130 is substantially the same as the angle α of the flange 85 of disposable cup 55 so that the edge 140 of disposable lid 130 mates with the flange 85 of the disposable cup 55. The angle γ centers the disposable lid 130 on the disposable cup 55. The angle γ of the disposable lid 130 also allows for additional sealing area without an increase in the overall outside
15 diameter of the fluid supply assembly.

The downward extending rib 150 on the inside of the disposable lid 130 fits inside the disposable cup 55. There can be one or more downward extending ribs 150 around the disposable lid 130 which extend part way around the inside of the disposable lid 55, or the
20 rib can extend all the way around. The downward extending rib 150 keeps the disposable lid 55 in place, and it can also act as a seal. The disposable lid 55 can also have a downwardly extending sealing bead 155 which contacts the flange 85 of the disposable cup 55 to improve sealing.

25 The reusable outer lid 170 is placed on top of the disposable lid 130. It is tightened to the reusable cup holder 90 using the connecting surface 125 of the reusable cup holder 90 and the complementary connecting surface 190 of the reusable outer lid 170. Suitable connecting surfaces and complementary connecting surfaces include, but are not limited to, threaded connections, lugs and grooves, and pins and slots.

30

The outer edge 180 of the reusable outer lid 170 has an angle δ which is substantially the same as the angle β of the flange 120 of reusable cup holder 90. The tightening of the reusable outer lid 170 to the reusable cup holder 90 clamps the edge 140

of disposable lid 130 and flange 85 of disposable cup 55 together between edge 180 of reusable outer lid 170 and flange 120 of reusable cup holder 90. The angle increases the clamping force without an increase in torque.

5 The angles α of the flange 85 of disposable cup 55, γ of the edge 140 of disposable lid 130, β of flange 120 of reusable cup holder 90, and δ of edge 180 of reusable outer lid 170 are generally in the range of about 10° to about 70° from the respective axis, typically about 20° to about 60° , more typically about 30° to about 50° , more typically about 35° to about 45° .

10

When the angles α and γ of the flange 85 of disposable cup 55 and the edge 140 of disposable lid 130 match the angle at which the fluid supply assembly is attached to the paint sprayer so that in use the disposable lid is substantially parallel to the paint axis of the paint sprayer, almost all of the paint in the disposable cup is used. Because the cost for
15 a typical mixed paint is over \$1.00 per fluid ounce, reducing paint waste is an important consideration.

A plug 235 can be used to cover the fitting 160 on the disposable lid 130. The plug 235 can fit inside or outside of the fitting 160. The plug 230 seals the opening 165 in the
20 fitting 160 for shaking or storage.

In one embodiment, the fluid supply assembly of the present invention is strong enough to be placed in a paint shaker machine without any additional support.

25 The conduit 210 is placed into the fitting 195 in the reusable outer lid 170. An optional filter 220 is inserted in the opening 215 of the conduit 210. Alternatively, the filter 220 could be placed in the fitting 160 of the disposable lid 130 or the fitting 195 of the reusable outer lid 170. The filter 220 can have a projection 225, if desired, which prevents the collapsing disposable cup 55 from blocking the opening 165 through to the
30 conduit 210. Projection 225 can also be used to remove the filter 220 for cleaning or disposal. The conduit 210 can be filled with solvent and plugged for storage, if desired. If an inside fitting plug 235 is used for the fitting 160 on the disposable cup 130, the same size plug may also fit in the conduit.

The fluid supply assembly is attached to the conduit 210. The conduit 210 connects to the reusable outer lid 170 and the paint sprayer 10 and provides a flow path from the interior 75 of the disposable cup 55 to the paint sprayer 10.

5 Various types of conduits could be used, as are well known to those of skill in the art. For example, U.S. Serial No. 10/458,436, filed June 10, 2003, entitled "Friction Fit Paint Cup Connection" describes a suitable conduit.

10 Another suitable conduit is shown in Figs. 11-15. The conduit can be an adapter 505 for connecting between paint sprayer 10 and outer lid 508. Adapter 505 includes a first end 510 engagable with paint sprayer 10, shown in Fig. 1, a second end 515 engagable with reusable outer lid 508, and a hollow bore 520 between first end 510 and second end 515.

15 In one embodiment, the first end 510 has a diameter smaller than the second end 515. The first end 510 is generally cylindrical in shape. The first end 510 has a connecting surface 525 for engaging with a complementary connecting surface 530 on the paint sprayer 10. Suitable connecting surface 525 and complementary connecting surface 530 include, but are not limited to, threading helical surfaces, lugs and grooves, tapered
20 connections, bayonet connections, snap connections, or first end 510 can be integral with paint sprayer 10 so that the adapter 505 is a feed conduit into sprayer 10. Desirably, the connecting surface 525 and complementary connecting surface 530 are threads of a typical size and pitch for paint sprayers so that the fluid supply assembly can be used with any of several sprayers.

25

The second end 515 has a portion having a first shape 535 and a portion having a second shape 540. The portion having a first shape 535 can be flat and the portion having the second shape 540 can be curved, if desired. Alternatively, the portion having the first shape can have a simple or complex shape, including, but not limited to, curved outward
30 or inward. If the portion having the first shape is curved, it should have a different curvature from that of the portion having the second shape. The portion having the second shape can also have a shape other than curved. Desirably, the second end 515 has opposing flat portions 535 and opposing curved portions 540. There can be one or more

curved portions, and one or more flat portions. Desirably, there are two opposing flat portions and two opposing curved portions.

The outer lid 508 has an integral generally cylindrical fitting 545 with an opening 550 therethrough. The opening 550 is generally circular. The opening 550 in the outer lid 508 has at least one tab 555 extending inward at the upper edge of the opening 550. Tab 555 has a shape that allows the portion having the first shape to pass next to it, but not the portion having the second shape, so that the second end 515 can be inserted into opening 550. If a flat portion 535 is used, tab 555 is typically flat. Tab 555 can be at the edge of the upper end of the fitting 545, or it can be downward from the edge, as desired.

There is at least one horizontal stop 560 in opening 550 below tab 555. Second end 515 has a height so that it fits between horizontal stop 560 and tab 555 of the fitting 545 so that the second end 515 enters only the desired distance. When second end 515 hits horizontal stop 560, the adapter 505 is rotated to lock the fluid supply assembly to the paint sprayer 10, as shown in Fig. 15. Alternatively, the outer lid 508 could be rotated onto the adapter 505. When the adapter 505 is rotated, tabs 555 are engaged with the top of curved portion 540 of second end 515.

There is at least one vertical stop 562 on the inside of opening 550. Vertical stop 562 prevents the adapter 505 from rotating so far that the flat portions 535 again become mated with the tabs 555 so that the adapter 505 could become disengaged. Vertical stops 562 can extend from tab 555 to horizontal stop 560, if desired. Alternatively, vertical stops 562 can extend part of the distance between tab 555 and horizontal stop 560.

The adapter 505 cannot be rotated until it is fully inserted into opening 550 because of flat portions 535 and curved portions 540 of second end 515, flat tabs 555 of the fitting 545, and the height of second end 515. This prevents the fluid supply assembly from falling off the adapter 505 due to improper assembly of the connection. In addition, the sides of fitting 545 support the curved portion 540 of second end 515 which reduces the ability of second end 515 to move within fitting 545. This helps to provide a stable connection between the fluid supply assembly and the adapter.

The disposable lid 565 has a fitting 570. As the second end 515 of the adapter 505 enters the fitting 545 of the outer lid 508, the fitting 570 of the disposable lid 565 enters the bore 520 of the adapter 505. This connects the interior of the fluid supply assembly to the passageway in the spray gun.

5

An alternate embodiment for the reusable outer lid is shown in Fig. 4. In this embodiment, the reusable outer lid 300 has an inner portion 305 and an outer portion 310. The outer portion 310 is generally frustoconical. The outer edge 315 defines an axis 320. The angle δa of the outer edge 315 is in a range of from about 10° to about 70° from the axis 320. As in the first embodiment, the angle δa is substantially the same as the angle β of the flange 120 of reusable cup holder 90.

The inner portion 305 is substantially flat. Alternatively, it could be at an angle different from the angle δa of the outer edge 315. It can optionally include one or more upward extending prongs 325. The prongs 325 can extend all or part of the way around the reusable outer lid 300. They can be positioned to mate with the legs 112 of an adjacent reusable cup holder 90a, allowing the fluid supply assemblies to be stacked on top of one another.

If the distance across the legs 112 of the reusable cup holder is smaller than the diameter of the lower end of the reusable cup and the reusable cup holder is to be used in a paint shaker, it may be desirable to include a second ring on the bottom of the reusable cup holder. The second ring should be the same (or substantially the same) diameter as the lower end of the reusable cup holder in order to transfer the paint shaker's clamping force to the side wall of the reusable cup holder, reducing deflection of the bottom of the reusable cup holder.

The reusable outer lid has a fitting 330 integrally connected to the inner portion 305. The fitting 330 has an opening 335 extending through it.

30

The outer edge 315 of the reusable outer lid 300 mates with the flange 120 of the reusable cup holder 90. There is a complementary connecting surface 340 at the outer edge 315 of the reusable outer lid 300. The complementary connecting surface 340 mates

with the connecting surface 125 of the reusable cup holder 90 to seal the reusable cup holder 90 and reusable outer lid 300 together.

An alternative embodiment of the disposable lid is shown in Figs. 5-6. The disposable lid 350 has an inner portion 355 and an outer portion 360. The outer portion 360 is generally frustoconical. The outer edge 365 of the outer portion 360 defines an axis 370. The angle γ_a of the outer edge 365 of the outer portion 360 is in a range of from about 10° to about 70° from the axis 370. As in the first embodiment, the angle γ_a is substantially the same as the angle α of the flange 85 of disposable cup 55.

The inner portion 355 has a generally frustoconical part 375 and an upwardly extending projection 380 at the outer end. The upwardly extending projection 380 is connected to the outer portion 360. There is a fitting 385 integrally connected to the inner portion 355. The fitting 385 has an opening 390 extending through it.

The outer portion 360 mates with the flange 85 of the disposable cup 55. The upwardly extending projection 380 fits inside the outlet end 65 the disposable cup 55 forming an additional seal.

Alternate embodiments of the disposable cup are shown in Figs. 7-10. In Fig. 7, the disposable cup 400 has a generally cylindrical lower side wall portion 405, a generally frustoconical intermediate side wall portion 415, and a generally cylindrical upper side wall portion 420.

The outlet end 425 at the top of the disposable cup 400 is open, and the bottom 430 is closed. The lower side wall portion 405, intermediate side wall portion 415, and upper side wall portion 420, outlet end 425, and bottom 430 define an interior 435. The interior 435 is smaller than the interior 75. The smaller diameter of the lower side wall portion allows accurate measuring of the paint ratios when less paint is to be used.

The outlet end 425 defines an axis 440. There is a flange 445 extending outward and downward from the edge of the outlet end 425. The flange 445 extends downward at an angle α_a in a range of from about 10° to about 70° from the axis 440 of the outlet end

425. The outlet end 425 is adapted to be placed into the reusable cup holder, so it sized to fit in the reusable cup holder.

Alternatively, the generally cylindrical lower side wall portion could be off centered, i.e., not concentric with the upper side wall portion. This would bring the lower side wall portion close to the side wall of the reusable cup holder, allowing easy reading of any measuring indicia.

In Figs. 8-10, the disposable cup 450 has a generally elliptical lower side wall portion 455, and intermediate side wall portion 460 extending from the lower side wall portion to the generally cylindrical upper side wall portion 465.

The outlet end 470 at the top of the disposable cup 450 is open, and the bottom 475 is closed. The lower side wall portion 455, intermediate side wall portion 460, and upper side wall portion 465, outlet end 470, and bottom 475 define an interior 480. The interior 480 is smaller than the interior 75. The elliptical shape makes it easier to read the indicia for measuring paint because the disposable cup extends close to the reusable cup holder. The longer axis of the ellipse can extend all or substantially all the way across the diameter of the reusable cup holder, or something less than all or substantially all the way across the diameter.

The outlet end 470 defines an axis 485. There is a flange 490 extending outward and downward from the edge of the outlet end 470. The flange 490 extends downward at an angle α in a range of from about 10° to about 70° from the axis 485 of the outlet end 470. The outlet end 470 is adapted to be placed into the reusable cup holder, so it sized to fit in the reusable cup holder.

In these embodiments, the distance across the outlet end of the disposable cup is greater than the distance across the bottom in at least one direction. The smaller portion of the disposable cup can extend the entire height of the side wall or less than the entire height of the side wall. If the side wall is cylindrical, and the smaller diameter portion extends the entire height of the sidewall, it can be connected to the flange by a flat annular portion. If it does not extend the entire height of the side wall, it can be can be connected

by a generally frustoconical upper side wall portion. Other side wall arrangements are possible, as are well known to those of skill in the art.

This embodiment of the disposable cup can be used with the reusable cup holder
5 and outer lid and disposable lid without any modification to the assembly, allowing
different sizes of disposable cups to be used in the fluid supply assembly.

The fluid supply assembly has been shown and described with the disposable cup
and reusable cup holder being generally cylindrical, which is a typical shape because of
10 ease of manufacture and use. However, it could be made in other shapes, including, but
not limited to, square, triangular, pentagonal, elliptical, etc.

While certain representative embodiments and details have been shown for
purposes of illustrating the invention, it will be apparent to those skilled in the art that
15 various changes in the compositions and methods disclosed herein may be made without
departing from the scope of the invention, which is defined in the appended claims.

What is claimed is:

1. A flexible, disposable cup comprising a side wall, an open outlet end, and a closed bottom defining an interior, the outlet end defining an axis, and a flange extending outward and downward from an edge of the outlet end of the disposable cup at an angle.
- 5 2. The disposable cup of claim 1 wherein the angle of the flange is in a range of from about 10° to about 70° from the axis of the outlet end.
3. The disposable cup of claim 1 wherein the disposable cup is made of a substantially transparent polymeric material.
- 10 4. The disposable cup of claim 1 wherein the disposable cup has indicia for measuring fluids on the side wall.
5. The disposable cup of claim 1 wherein the flange of the disposable cup further
15 comprises a removal tab.
6. The disposable cup of claim 1 wherein the side wall is generally cylindrical.
7. The disposable cup of claim 1 wherein a distance across the outlet end is greater
20 than a distance across the bottom in at least one direction.
8. The disposable cup of claim 7 wherein the side wall has a generally cylindrical lower side wall portion and generally frustoconical upper side wall portion.
- 25 9. The disposable cup of claim 7 wherein the side wall has a generally cylindrical lower side wall portion, a generally frustoconical intermediate side wall portion, and a generally cylindrical upper side wall portion.
10. The disposable cup of claim 7 wherein the side wall is generally cylindrical and an
30 upper end of the side wall is connected to the flange by a flat annular portion.

11. The disposable cup of claim 7 wherein the side wall has a generally elliptical lower side wall portion, a generally cylindrical upper side wall portion, and an intermediate side wall portion extending from the lower side wall portion to the upper side wall portion.
- 5 12. The disposable cup of claim 7 wherein the side wall has a generally cylindrical lower side wall portion, a generally cylindrical upper side wall portion, and an intermediate side wall portion extending from the lower side wall portion to the upper side wall portion.
- 10 13. A disposable lid comprising an inner portion and an outer portion, the outer portion being generally frustoconical and defining an edge, the edge defining an axis, the edge of the disposable lid having a frustoconical angle, the angle of the edge on the disposable lid being substantially the same as an angle of a flange on a disposable cup, the disposable lid being adapted to fit over the disposable cup, the edge of the disposable lid mating with the
15 flange of the disposable cup, the disposable lid having a fitting integrally connected to the inner portion, the fitting having an opening therethrough.
14. The disposable lid of claim 13 wherein the angle of the edge is in a range of from about 10° to about 70° from the axis of the edge
20
15. The disposable lid of claim 13 wherein the disposable lid is made of a substantially transparent polymeric material, a translucent polymeric material, or an opaque polymeric material.
- 25 16. The disposable lid of claim 13 wherein the disposable lid has a downward extending rib adapted to mate with an inside of the side wall of the disposable cup and form a seal.
17. The disposable lid of claim 13 wherein the edge of the disposable lid has a
30 downwardly projecting sealing bead adapted to contact the flange of the disposable cup.
18. The disposable lid of claim 13 further comprising a plug to close the fitting of the disposable lid.

19. The disposable lid of claim 18 wherein the plug fits inside the fitting of the disposable lid.
20. The disposable lid of claim 18 wherein the plug fits outside the fitting of the
5 disposable lid.
21. The disposable lid of claim 13 wherein the edge of the disposable lid further comprises a removal tab.
- 10 22. The disposable lid of claim 13 wherein the inner portion of the disposable lid is generally frustoconical.
23. The disposable lid of claim 13 wherein the inner portion of the disposable lid has a generally frustoconical part extending outward from the fitting and an upwardly extending
15 projection at an outer end of the generally frustoconical part, the upwardly extending projection being connected to the outer portion of the disposable lid.
24. A fluid supply assembly comprising:
a flexible, disposable cup having a side wall, an open outlet end, and a closed
20 bottom defining an interior, the outlet end defining an axis, and a flange extending outward and downward from an edge of the outlet end of the disposable cup at an angle;
a reusable cup holder having a side wall, an open upper end, and a lower end, the lower end having an opening therein, the upper end defining an axis, a flange extending
25 outward and downward from an edge of the upper end of the reusable cup holder at an angle, the angle of the flange of the reusable cup holder being substantially the same as the angle of the flange of the disposable cup whereby the flange of the reusable cup holder supports the flange of the disposable cup, a connecting surface at the upper end, the reusable cup holder being adapted to receive the disposable cup;
a disposable lid having an inner portion and an outer portion, the outer portion
30 having an edge having a frustoconical angle, the angle of the edge of the disposable lid being substantially the same as the angle of the flange of the disposable cup, the disposable lid being adapted to fit over the disposable cup, the edge of the disposable lid

mating with the flange of the disposable cup, the disposable lid having a fitting integrally connected to the inner portion, the fitting having an opening therethrough; and

5 a reusable outer lid having an inner portion and a outer portion, the outer portion having an edge having a frustoconical angle, the angle of the edge of the reusable outer lid being substantially the same as the angle of the flange of the reusable cup holder, the reusable outer lid being adapted to fit over the reusable cup holder, the edge of the reusable outer lid mating with the flange of the reusable cup holder, the reusable outer lid having a fitting integrally connected to the inner portion, the fitting of the reusable outer lid having an opening therethrough, the fitting of the disposable lid adapted to fit into the fitting of the reusable outer lid, a complementary connecting surface at the edge of the reusable outer lid, the complementary connecting surface of the reusable outer lid adapted to mate with the connecting surface of the reusable cup holder to seal the reusable cup holder and reusable outer lid together.

15 25. The fluid supply assembly of claim 24 wherein the angle of the flange of the disposable cup is in a range of from about 10° to about 70° from the axis of the outlet end.

20 26. The fluid supply assembly of claim 24 wherein the angle of the flange of the reusable cup holder is in a range of from about 10° to about 70° from the axis of the upper end.

25 27. The fluid supply assembly of claim 24 wherein the angle of the edge of the disposable lid is in a range of from about 10° to about 70° from an axis defined by the edge.

28. The fluid supply assembly of claim 24 wherein the angle of the edge of the reusable outer lid is in a range of from about 10° to about 70° from an axis defined by the edge.

30 29. The fluid supply assembly of claim 24 further comprising a conduit having an opening therethrough, the conduit adapted to mate with the fitting of the reusable outer lid and the fitting of the disposable lid to provide a fluid connection from the interior of the disposable cup through the conduit.

30. The fluid supply assembly of claim 24 wherein the reusable cup holder is made of a substantially transparent polymeric material.

31. The fluid supply assembly of claim 24 wherein the disposable cup is made of a substantially transparent polymeric material.

32. The fluid supply assembly of claim 24 wherein the reusable outer lid is made of a polymeric material.

33. The fluid supply assembly of claim 24 wherein the disposable lid is made of a substantially transparent polymeric material.

34. The fluid supply assembly of claim 24 wherein the disposable cup has indicia for measuring fluids on the side wall.

35. The fluid supply assembly of claim 24 wherein the reusable cup has indicia for measuring fluids on the side wall.

36. The fluid supply assembly of claim 24 wherein the disposable lid has a downward extending rib adapted to mate with an inside of the side wall of the disposable cup and form a seal.

37. The fluid supply assembly of claim 24 wherein the inner portion of the reusable outer lid is generally frustoconical.

38. The fluid supply assembly of claim 37 wherein an angle of the inner portion is substantially the same as the angle of the edge of the reusable outer lid

39. The fluid supply assembly of claim 38 wherein the inner portion of the reusable outer lid is flat.

40. The fluid supply assembly of claim 24 wherein the inner portion of the reusable outer lid has an upwardly extending projection.

41. The fluid supply assembly of claim 40 wherein the lower end of the reusable cup holder has a downwardly extending projection, the downwardly extending projection adapted to fit inside the upwardly extending projection of the reusable outer lid of an adjacent reusable outer lid to allow secure stacking of the fluid supply assemblies.

5

42. The fluid supply assembly of claim 24 wherein the edge of the disposable lid has a downwardly projecting sealing bead adapted to contact the flange of the disposable cup.

43. The fluid supply assembly of claim 24 wherein the connecting surface of the reusable cup and the complementary connecting surface of the reusable lid are selected from complementary threads, lugs and grooves, or pins and slots.

10

44. The fluid supply assembly of claim 24 wherein the reusable outer lid has at least one opening in the inner portion or the outer portion.

15

45. The fluid supply assembly of claim 24 further comprising a plug to close the fitting of the disposable lid.

46. The fluid supply assembly of claim 45 wherein the plug fits inside the fitting of the disposable lid.

20

47. The fluid supply assembly of claim 45 wherein the plug fits outside the fitting of the disposable lid.

48. The fluid supply assembly of claim 24 wherein the disposable cup further comprises a removal tab on the flange.

25

49. The fluid supply assembly of claim 24 wherein the disposable lid further comprises a removal tab on the edge.

30

50. The fluid supply assembly of claim 24 wherein the side wall of the disposable cup is generally cylindrical.

51. The fluid supply assembly of claim 24 wherein a distance across the outlet end of the disposable cup is greater than a distance across the bottom in at least one direction.

52. The fluid supply assembly of claim 51 wherein the side wall of the disposable cup
5 has a generally cylindrical lower side wall portion and a generally frustoconical upper side wall portion.

53. The fluid supply assembly of claim 51 wherein the side wall of the disposable cup
10 has a generally cylindrical lower side wall portion, a generally frustoconical intermediate side wall portion, and a generally cylindrical upper side wall portion.

54. The fluid supply assembly of claim 51 wherein the side wall of the disposable cup is generally cylindrical and an upper end of the sidewall is connected to the flange by a flat annular portion.

15

55. The fluid supply assembly of claim 51 wherein the side wall of the disposable cup has a generally elliptical lower side wall portion, a generally cylindrical upper side wall portion, and an intermediate side wall portion extending from the lower side wall portion to the upper side wall portion.

20

56. The fluid supply assembly of claim 51 wherein the side wall of the disposable cup has a generally cylindrical lower side wall portion, a generally cylindrical upper side wall portion, and an intermediate side wall portion extending from the lower side wall portion to the upper side wall portion.

25

57. The fluid supply assembly of claim 24 wherein the inner portion of the disposable lid is generally frustoconical.

58. The fluid supply assembly of claim 24 wherein the inner portion of the disposable
30 lid has a generally frustoconical part extending outward from the fitting and an upwardly extending projection at an outer end of the generally frustoconical part, the upwardly extending projection being connected to the outer portion of the disposable lid.

59. The fluid supply assembly of claim 24 further comprising a clear sheet having indicia for measuring fluids thereon, the clear sheet having a slot on a first side and a corresponding tab on an opposite side, the tab being adapted to fit into the slot so that the sheet forms a cylinder.

5

60. The fluid supply assembly of claim 59 wherein the indicia for measuring fluids comprises at least two universal scales.

61. The fluid supply assembly of claim wherein a diameter of the downwardly extending projection of the reusable cup holder is less than a diameter of the lower end, and further comprising a second downwardly extending projection having a diameter substantially the same as the diameter of the lower end.

62. A method of preparing a fluid supply assembly for use with a fluid supply applicator comprising:

providing a fluid supply assembly comprising:

a flexible, disposable cup having a side wall, an open outlet end, and a closed bottom defining an interior, the outlet end defining an axis, and a flange extending outward and downward from an edge of the outlet end of the disposable cup at an angle;

a reusable cup holder having a side wall, an open upper end, and a lower end, the lower end having an opening therein, the upper end defining an axis, a flange extending outward and downward from an edge of the upper end of the reusable cup holder at an angle, the angle of the flange of the reusable cup holder being substantially the same as the angle of the flange of the disposable cup whereby the flange of the reusable cup holder supports the flange of the disposable cup, a connecting surface at the upper end, the reusable cup holder being adapted to receive the disposable cup;

a disposable lid having an inner portion and an outer portion, the outer portion having an edge having a frustoconical angle, the angle of the edge of the disposable lid being substantially the same as the angle of the flange of the disposable cup, the disposable lid being adapted to fit over the disposable cup, the edge of the disposable lid mating with the flange of the

disposable cup, the disposable lid having a fitting integrally connected to the inner portion, the fitting having an opening therethrough; and a reusable outer lid having an inner portion and a outer portion, the outer portion having an edge having a frustoconical angle, the angle of the edge of the reusable outer lid being substantially the same as the angle of the flange of the reusable cup holder, the reusable outer lid being adapted to fit over the reusable cup holder, the edge of the reusable outer lid mating with the flange of the reusable cup holder, the reusable outer lid having a fitting integrally connected to the inner portion, the fitting of the reusable outer lid having an opening therethrough, the fitting of the disposable lid adapted to fit into the fitting of the reusable outer lid, a complementary connecting surface at the edge of the reusable outer lid, the complementary connecting surface of the reusable outer lid adapted to mate with the connecting surface of the reusable cup holder to seal the reusable cup holder and reusable outer lid together;

placing the disposable cup in the reusable cup holder;
filling the disposable cup with fluid;
placing the disposable lid on the disposable cup; and
placing the reusable outer lid on the reusable cup holder.

20

63. The method of claim 62 further comprising attaching the fluid supply assembly to the fluid applicator.

64. The method of claim 62 further comprising attaching a conduit to the fitting of the reusable outer lid.

65. The method of claim 62 further comprising:
providing a clear sheet having measuring indicia thereon, the clear sheet having a slot on a first side and a corresponding tab on an opposite side;
inserting the tab of the clear sheet into the slot so that the sheet forms a cylinder;
placing the disposable cup in the cylinder formed by the clear sheet;
measuring the fluid using the indicia on the clear sheet; and
removing the disposable cup from the cylinder formed by the clear sheet.

30

66. The method of claim 65 wherein the disposable cup is filled with fluid before the disposable cup is placed in the reusable cup holder.

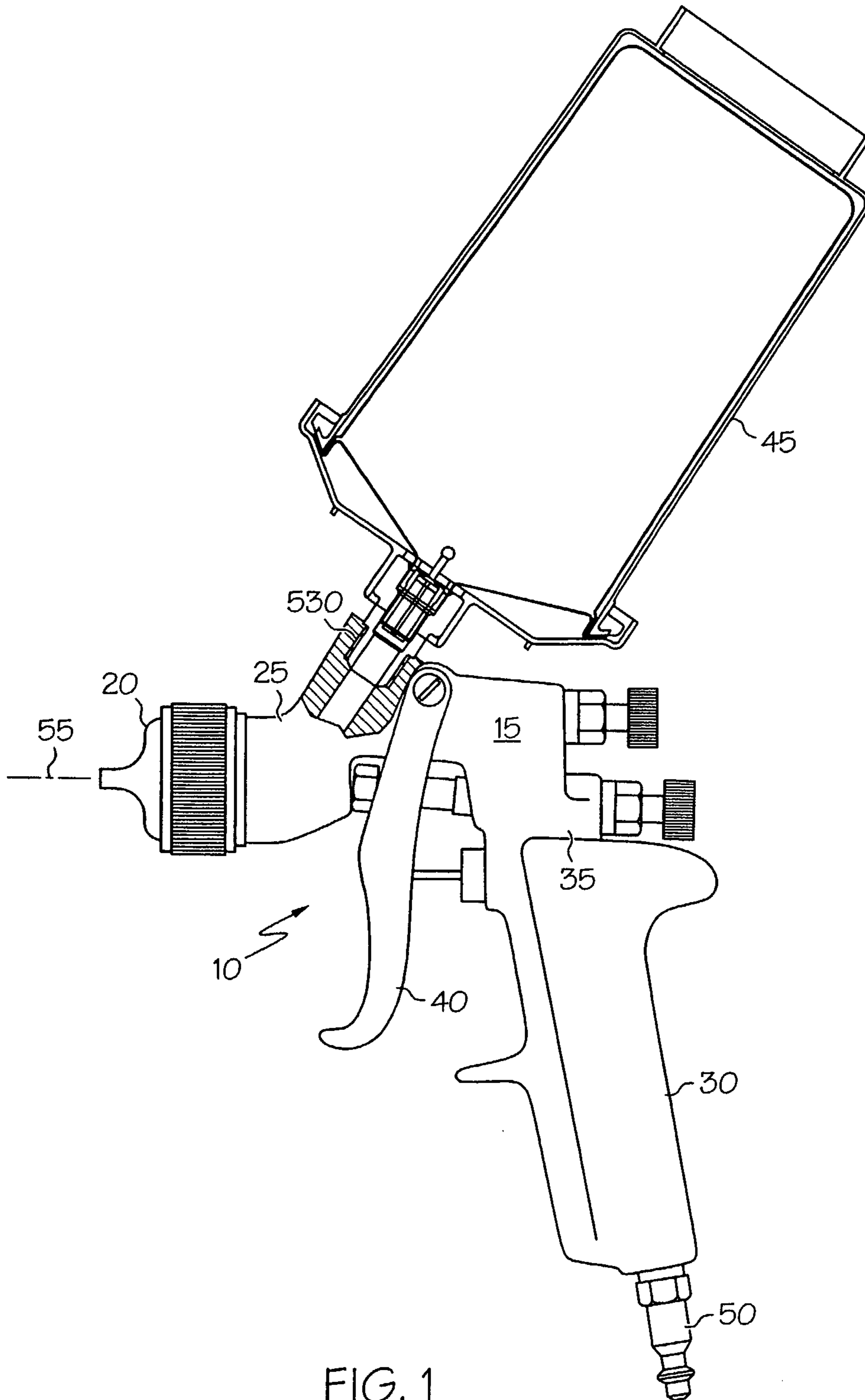
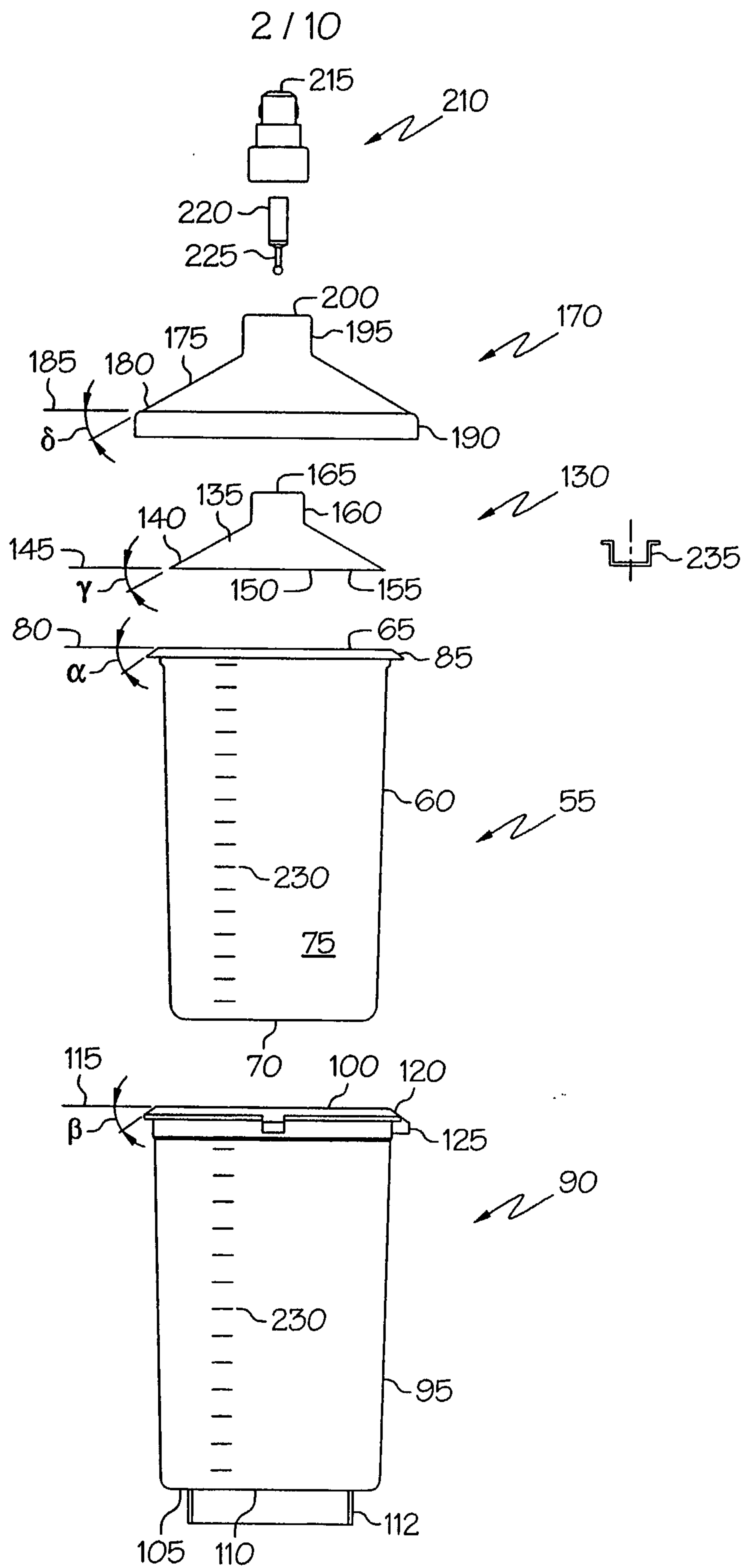

FIG. 1



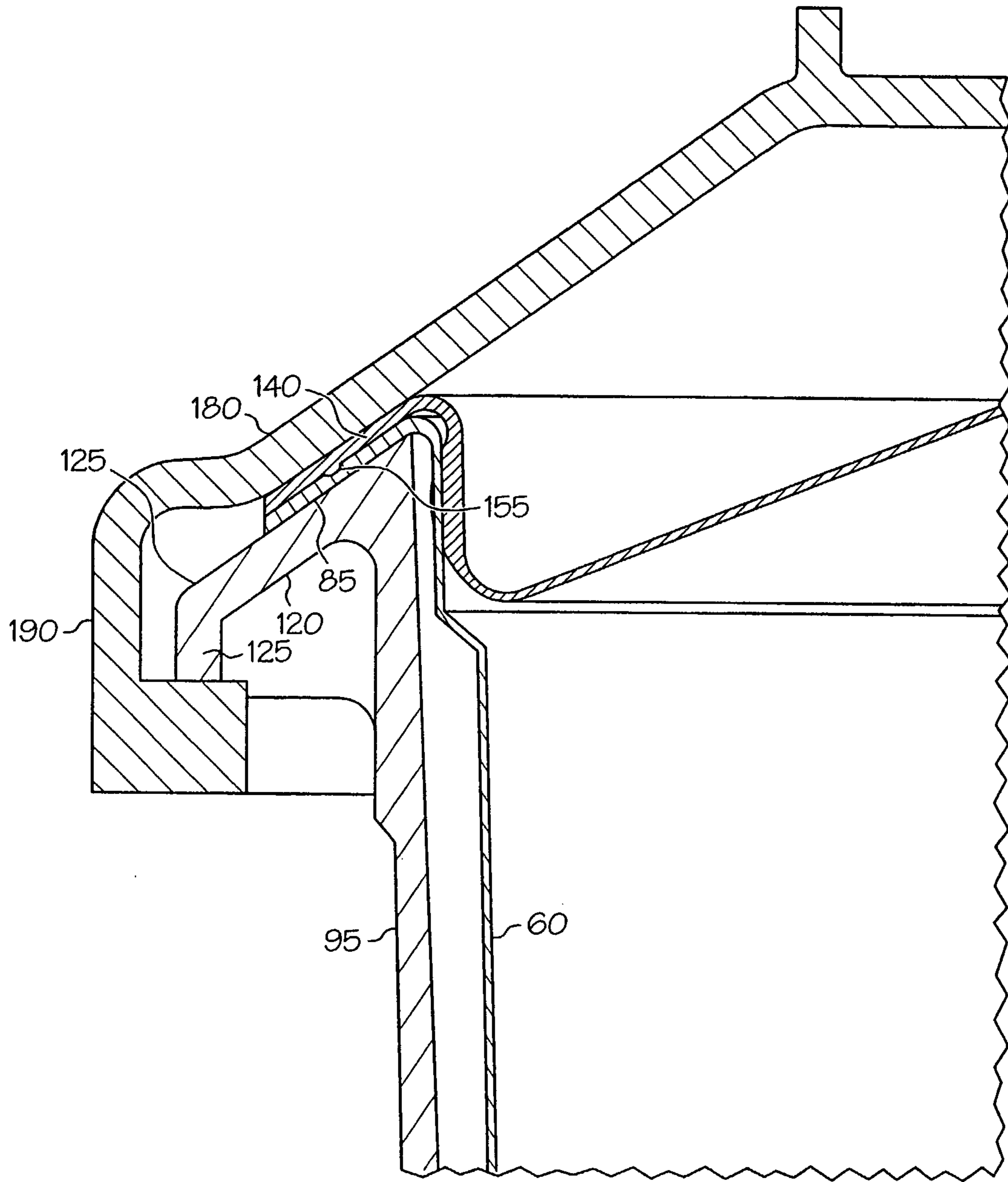

FIG. 3

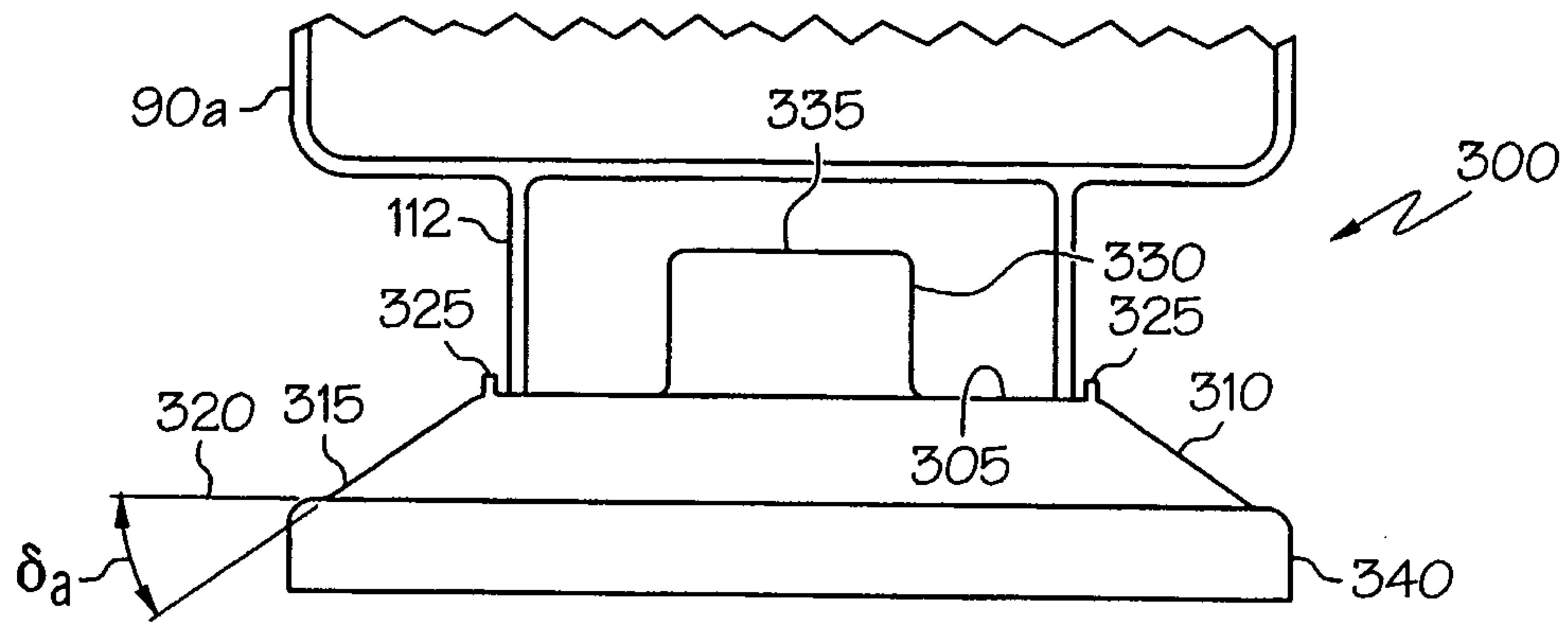

FIG. 4

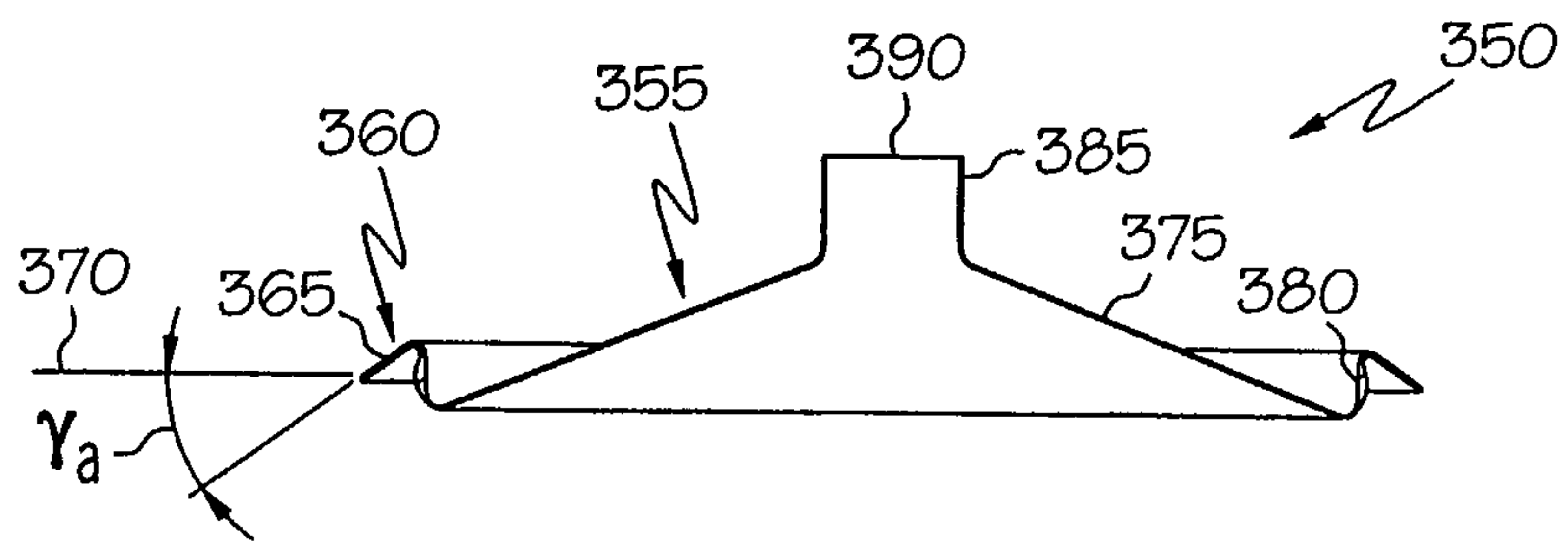

FIG. 5

5 / 10

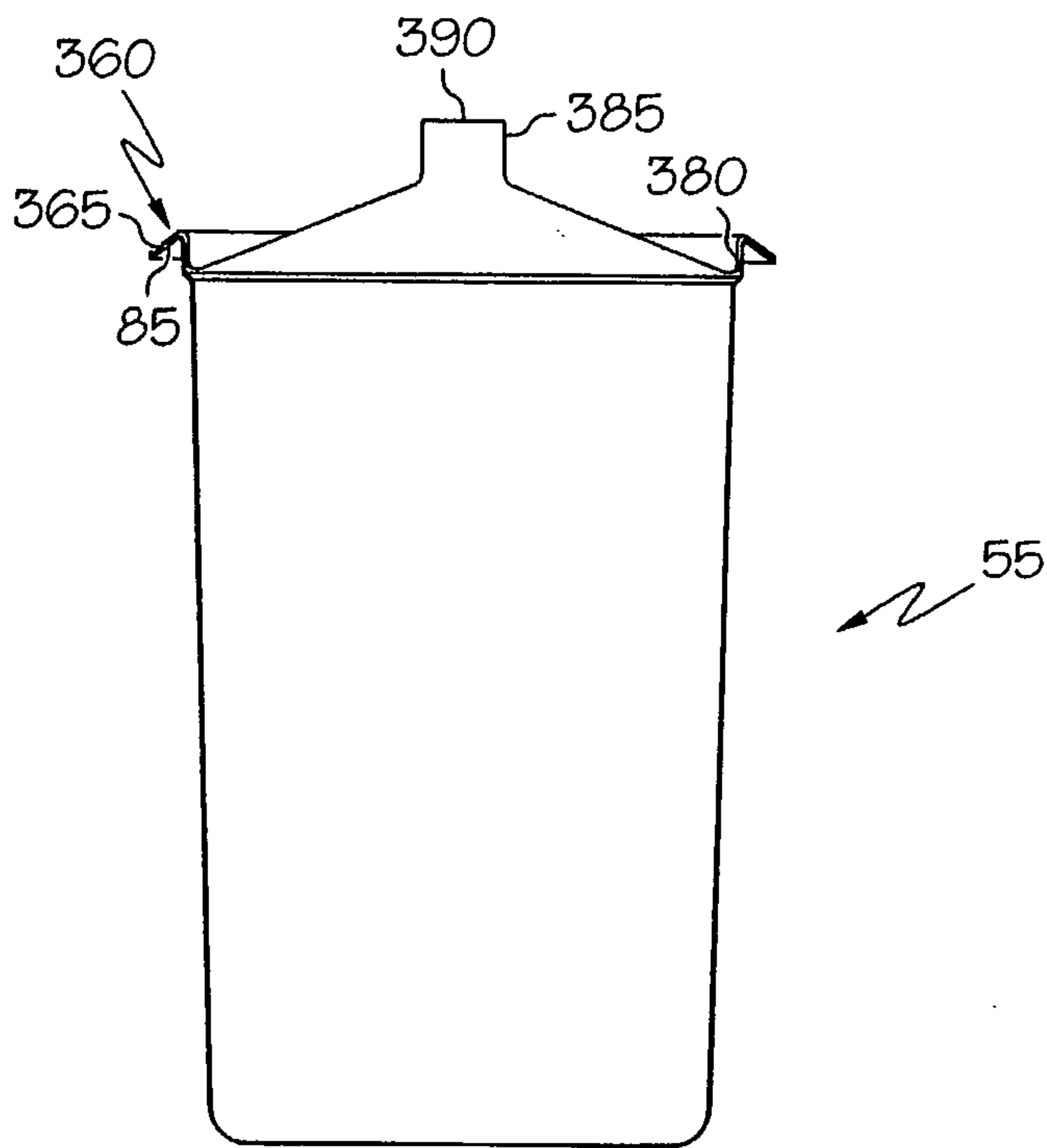

FIG. 6

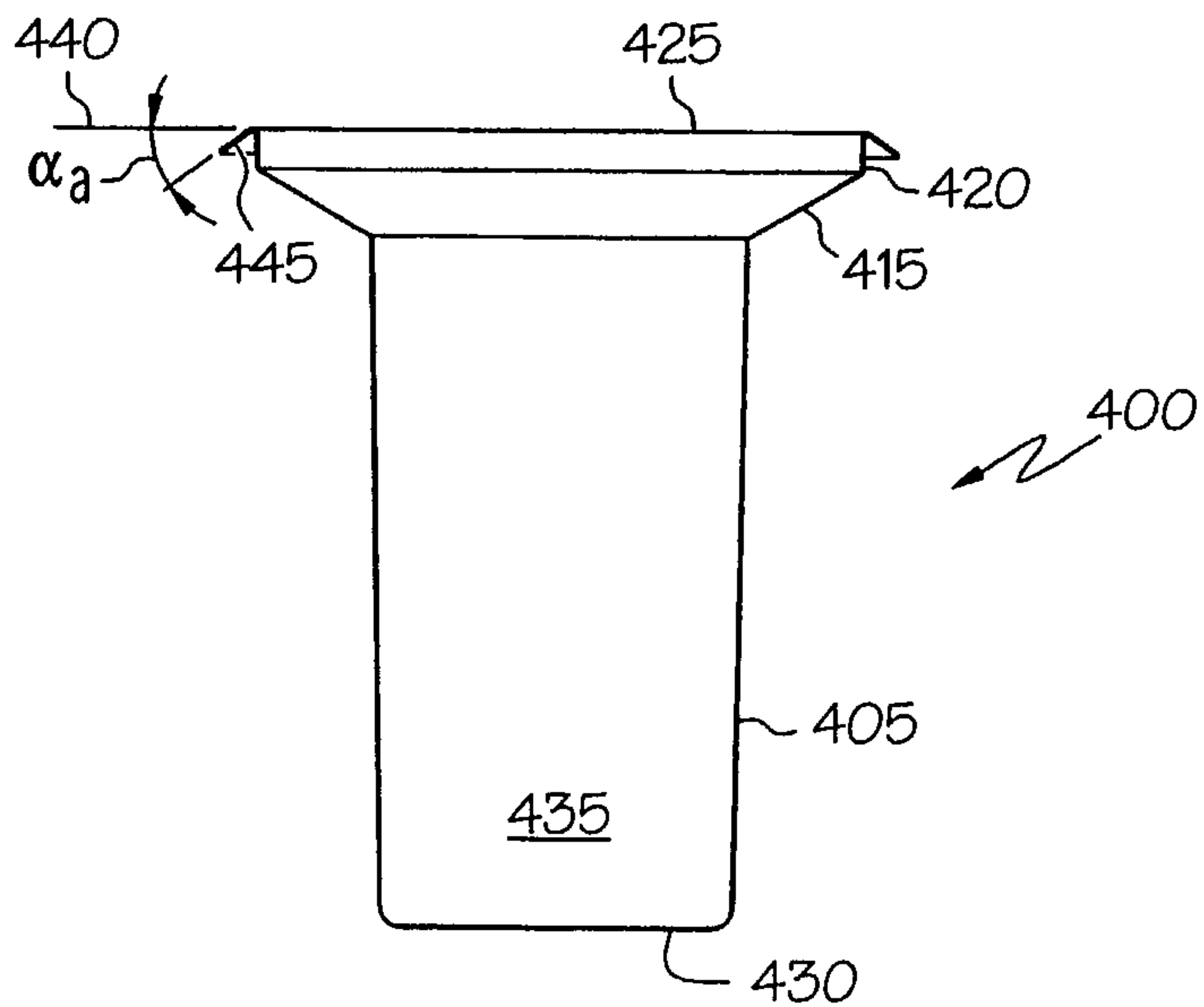

FIG. 7

6 / 10

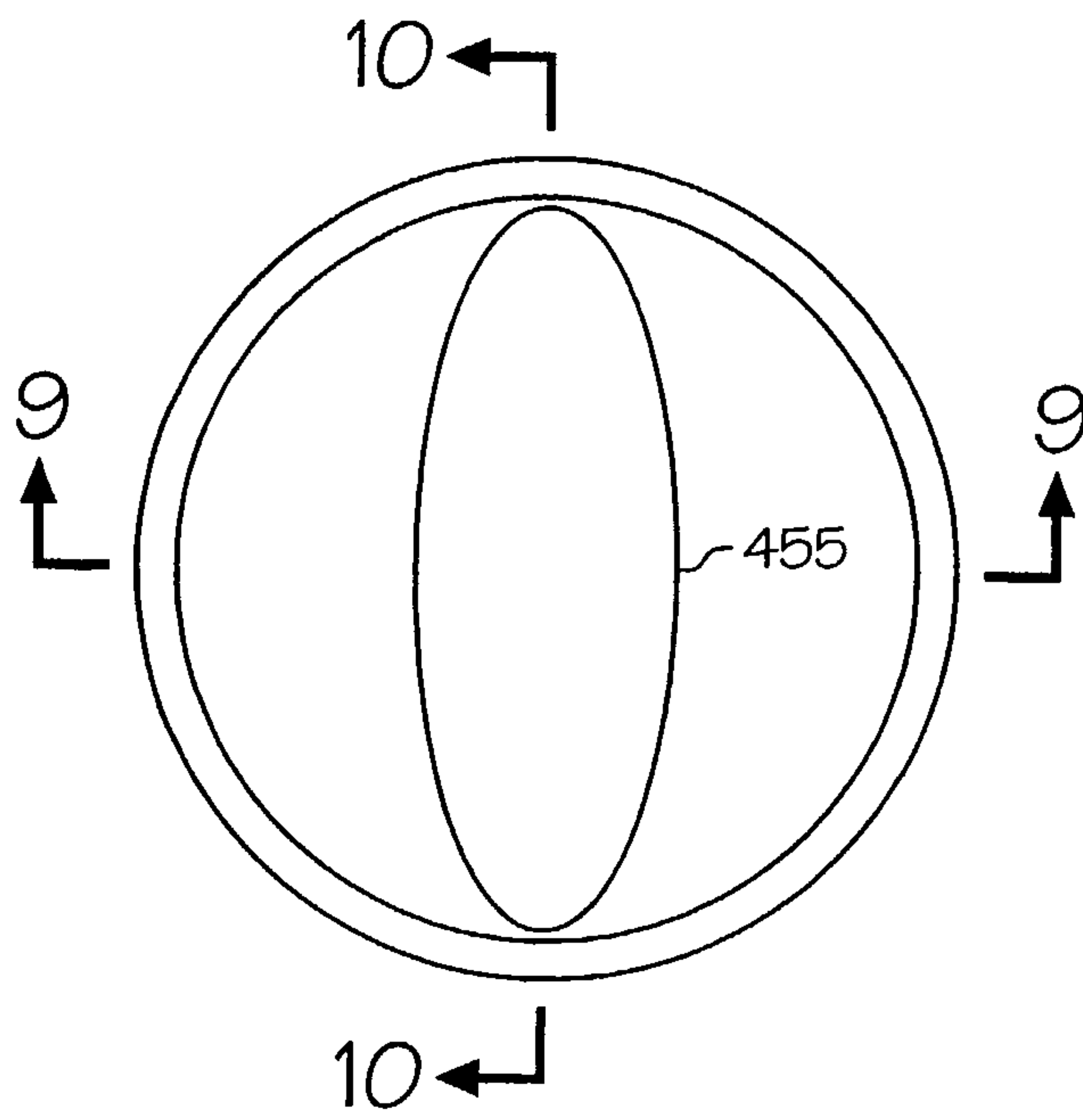

FIG. 8

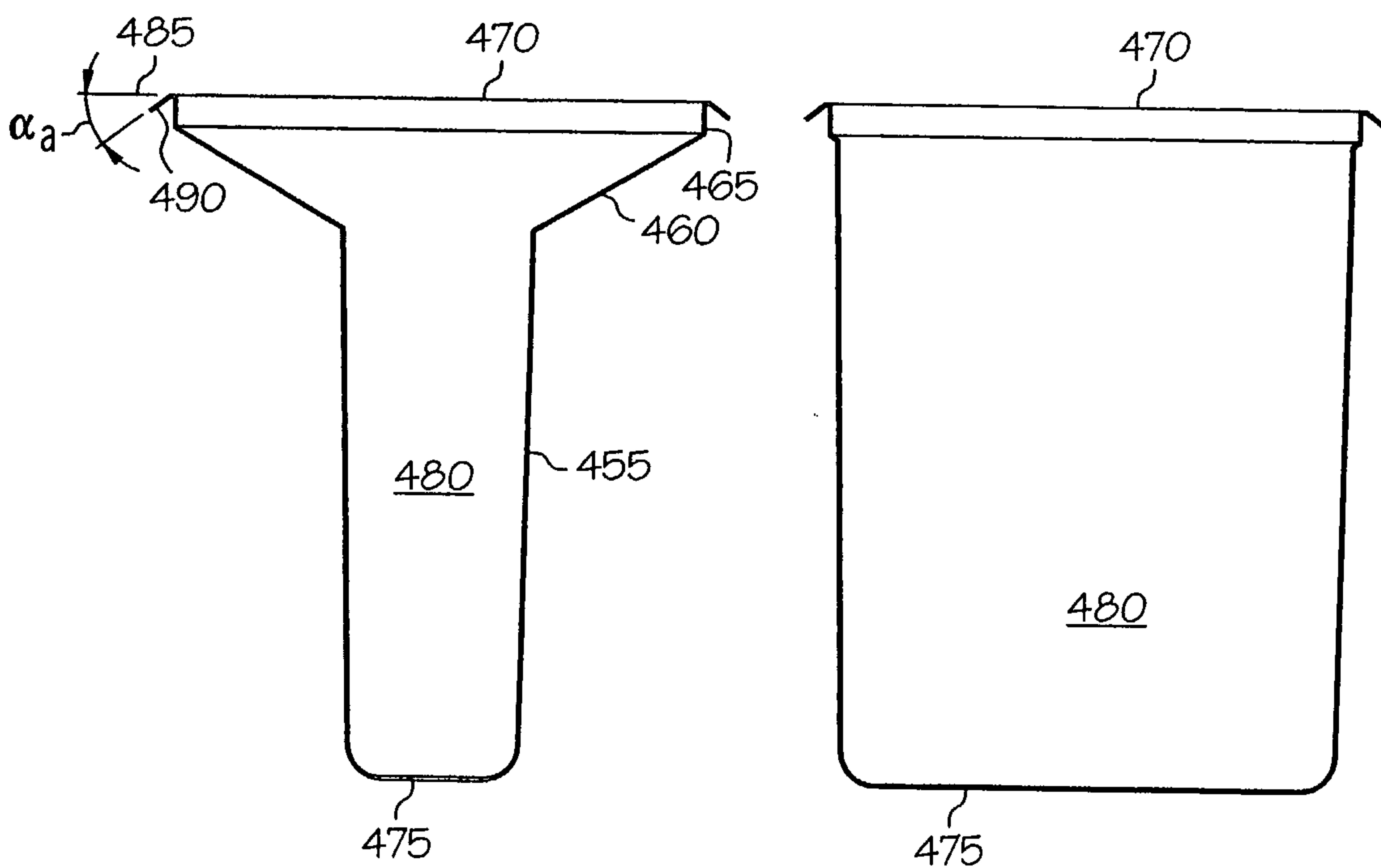

FIG. 9

FIG. 10

7 / 10

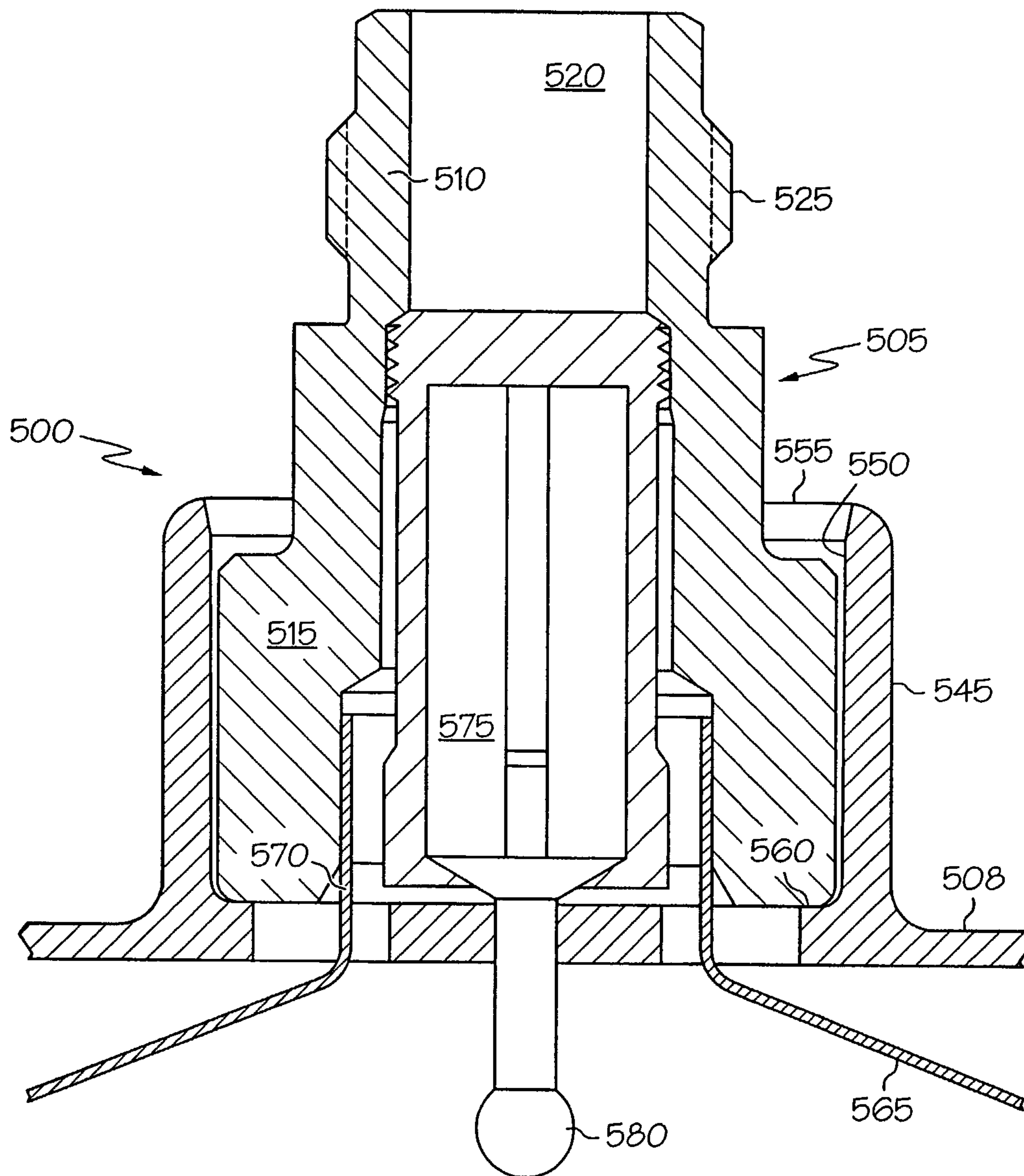

FIG. 11

8 / 10

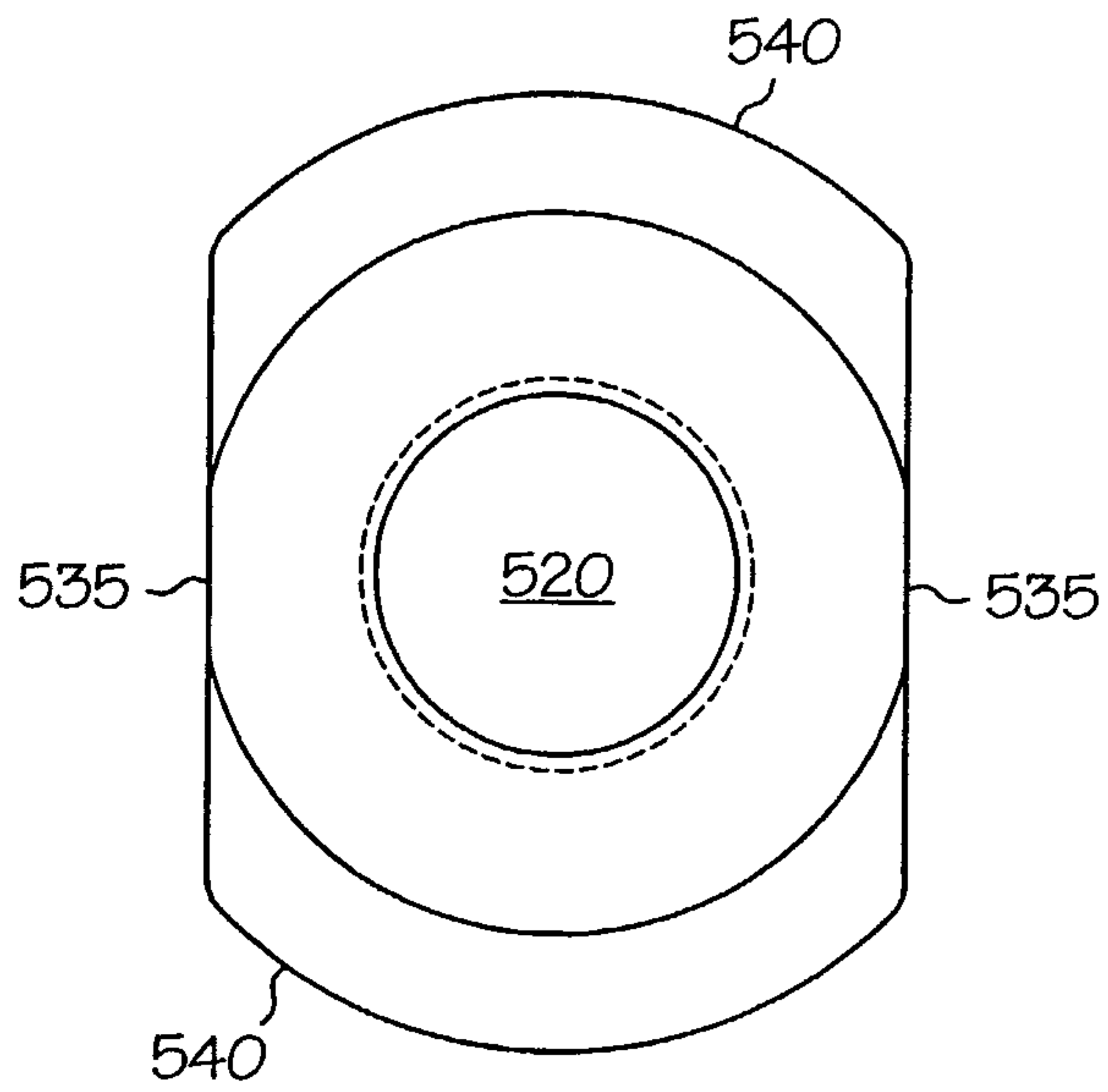

FIG. 12

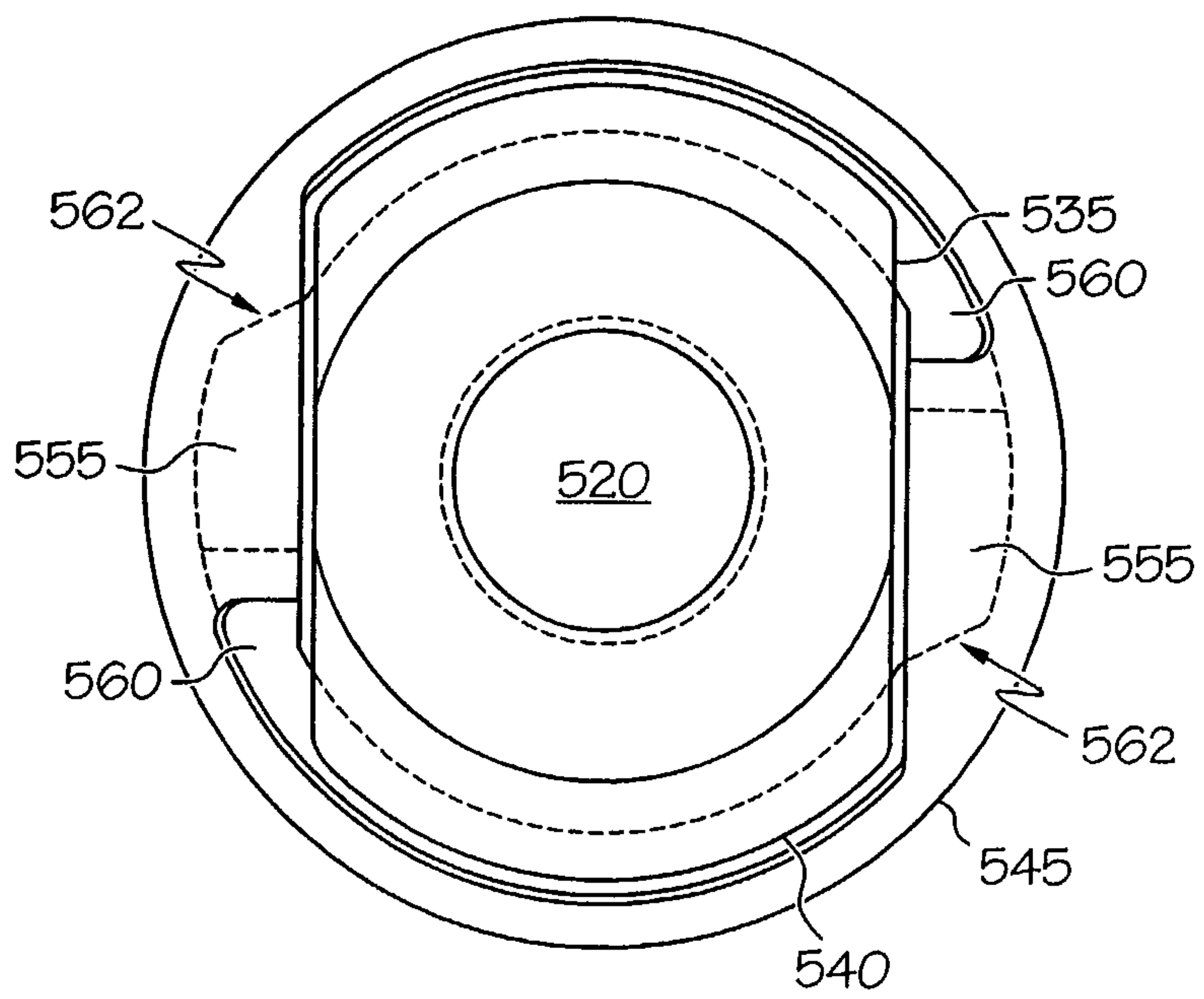

FIG. 13

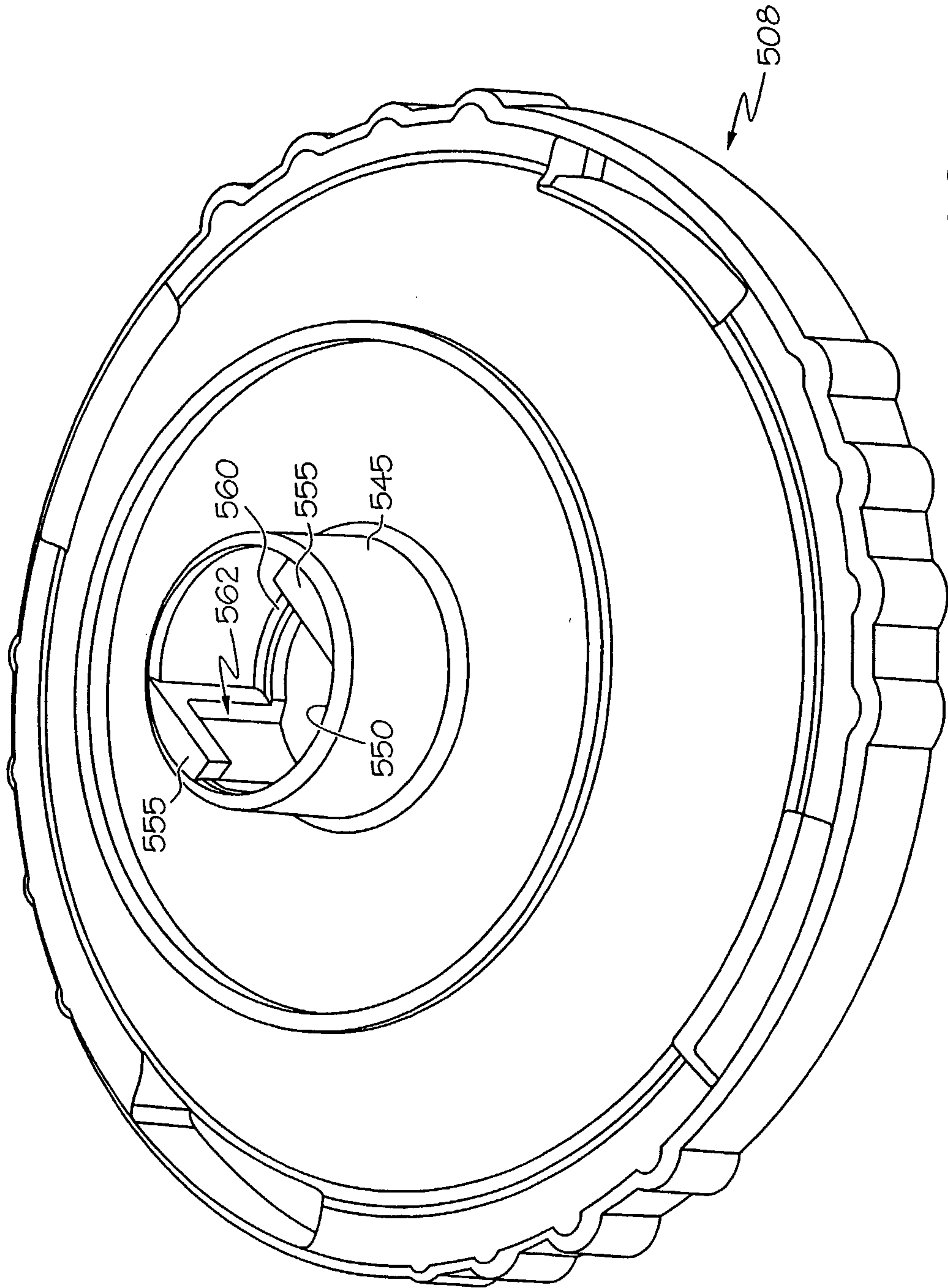

FIG. 14

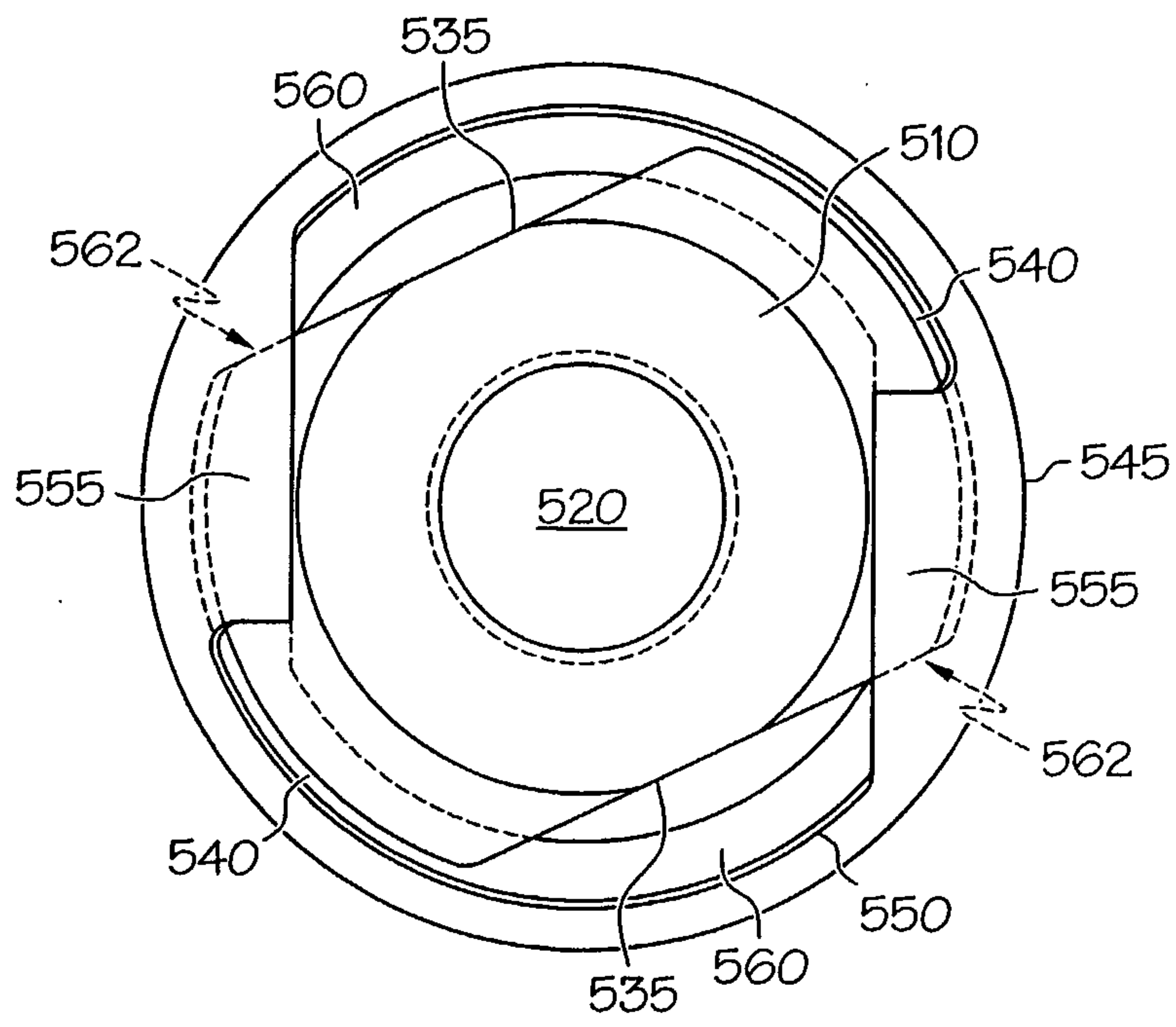

FIG. 15

