

(12) STANDARD PATENT
(19) AUSTRALIAN PATENT OFFICE

(11) Application No. **AU 2009257891 B2**

(54) Title
Hermetic packages with laser scored vent systems

(51) International Patent Classification(s)
B65D 33/16 (2006.01)

(21) Application No: **2009257891** (22) Date of Filing: **2009.05.20**

(87) WIPO No: **WO09/151901**

(30) Priority Data

(31) Number	(32) Date	(33) Country
61/060,205	2008.06.10	US

(43) Publication Date: **2009.12.17**

(44) Accepted Journal Date: **2014.02.27**

(71) Applicant(s)
Pliant LLC

(72) Inventor(s)
Wolak, Paul Z.;Su, Jau-Ming

(74) Agent / Attorney
Freehills Patent Attorneys, Level 43 101 Collins Street, Melbourne, VIC, 3000

(56) Related Art
DE 202007003168
WO 2006/034793
JP 11-079260
WO 2006/075141
US 2007/0215609
JP 2001-031148
US 3909582
US 7254873
US 6231236
US 2005/0208282

(12) INTERNATIONAL APPLICATION PUBLISHED UNDER THE PATENT COOPERATION TREATY (PCT)

(19) World Intellectual Property Organization
International Bureau



(43) International Publication Date
17 December 2009 (17.12.2009)

(10) International Publication Number
WO 2009/151901 A1

- (51) **International Patent Classification:**
B65D 33/16 (2006.01)
- (21) **International Application Number:**
PCT/US2009/044657
- (22) **International Filing Date:**
20 May 2009 (20.05.2009)
- (25) **Filing Language:** English
- (26) **Publication Language:** English
- (30) **Priority Data:**
61/060,205 10 June 2008 (10.06.2008) US
- (71) **Applicant (for all designated States except US):** **PLI-ANT CORPORATION** [US/US]; 1475 Woodfield Road, Suite 700, Schaumburg, IL 60173 (US).
- (72) **Inventors; and**
- (75) **Inventors/Applicants (for US only):** **SU, Jau-Ming** [US/US]; 13938 SE 241st Street, Kent, WA 98042 (US). **WOLAK, Paul, Z.** [US/US]; 7324 Franklin Park Boulevard, Indianapolis, IN 46259 (US).
- (74) **Agent:** **GROETKEN, Troy, A.;** McAndrews, Held & Malloy, Ltd., 500 W. Madison Street, 34th Floor, Chicago, IL 60661 (US).
- (81) **Designated States (unless otherwise indicated, for every kind of national protection available):** AE, AG, AL, AM, AO, AT, AU, AZ, BA, BB, BG, BH, BR, BW, BY, BZ, CA, CH, CN, CO, CR, CU, CZ, DE, DK, DM, DO, DZ, EC, EE, EG, ES, FI, GB, GD, GE, GH, GM, GT, HN, HR, HU, ID, IL, IN, IS, JP, KE, KG, KM, KN, KP, KR, KZ, LA, LC, LK, LR, LS, LT, LU, LY, MA, MD, ME, MG, MK, MN, MW, MX, MY, MZ, NA, NG, NI, NO, NZ, OM, PG, PH, PL, PT, RO, RS, RU, SC, SD, SE, SG, SK, SL, SM, ST, SV, SY, TJ, TM, TN, TR, TT, TZ, UA, UG, US, UZ, VC, VN, ZA, ZM, ZW.
- (84) **Designated States (unless otherwise indicated, for every kind of regional protection available):** ARIPO (BW, GH, GM, KE, LS, MW, MZ, NA, SD, SL, SZ, TZ, UG, ZM, ZW), Eurasian (AM, AZ, BY, KG, KZ, MD, RU, TJ, TM), European (AT, BE, BG, CH, CY, CZ, DE, DK, EE, ES, FI, FR, GB, GR, HR, HU, IE, IS, IT, LT, LU, LV, MC, MK, MT, NL, NO, PL, PT, RO, SE, SI, SK, TR), OAPI (BF, BJ, CF, CG, CI, CM, GA, GN, GQ, GW, ML, MR, NE, SN, TD, TG).
- Published:**
— with international search report (Art. 21(3))

(54) **Title:** HERMETIC PACKAGES WITH LASER SCORED VENT SYSTEMS

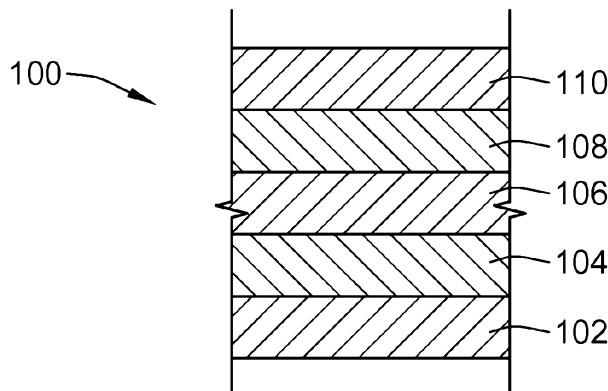

FIG. 1

(57) **Abstract:** A hermetically sealed package, for example a freezable, microwavable package containing a food product, having a sealing film that includes a vent system that is scored by a laser into the package. The vent system includes at least one linear or non-linear vent pattern scored into a portion of the outer surface of the sealing film so as to form at least one weakened wall pattern. According to certain embodiments, the vent pattern may be scored by a laser to a depth that does not perforate the sealing film. The inner surface of the sealing film that is adjacent to the weakened wall pattern is directly exposed to pressure that is generated in the inner region of the package during heating. According to some embodiments, the vent pattern may have a vent pattern span that is approximately 1 % to 50% of the size of the inner region span.

WO 2009/151901 A1

HERMETIC PACKAGES WITH LASER SCORED VENT SYSTEMS

BACKGROUND OF THE INVENTION

[0001] The present technology generally relates to venting systems for use with films that are suitable for use as, or with, food packaging. More specifically, the present technology relates to food packaging that includes, in certain embodiments, a freezable, microwaveable film layer having a venting system that facilitates the heating or cooking of hermetically packaged food contents at desirable temperatures and/or pressures.

[0002] In recent years, there has been an increase in the number of food products that are designed or intended to go directly from the freezer to the microwave for heating or cooking. Such food products often require packaging that also can go directly from freezer storage temperatures, typically temperatures ranging from about -20° C to about 0° C, to microwave heating or cooking temperatures ranging from about 71° C or greater. Additionally, it is desirable that such packaging perform without fracturing in the freezer, and without melting or bursting in the microwave. For example, with respect to foods such as vegetables, the temperatures reached during microwave cooking typically range from about 71° C to about 105° C. However, when the packaged food items include meats, fish, grease, and/or oils, for example, the temperature of the items can reach up to about 150° C when heated during microwave preparation.

[0003] Many freezable and microwaveable food packages can be made from, or include, a sealing film, such as the multilayered films discussed and disclosed in

-2-

U.S. Patent Application Nos. 11/374,893 and 11/650,903, both of which are incorporated herein by reference in their entirety. Further, such films may be used for a variety of different types of food packages, which may have a variety of sizes and configurations. For example, a sealing film may be configured to form a pouch, wherein the sealing film is oriented to provide an inner region that is configured to receive the placement of a food product. Further, the edges of the sealing film may be sealed together so that the food product in the inner region is hermetically sealed. Other food packages may include a tray container having a base and sidewalls that form the inner region. The inner region of the tray container may also include one or more food compartments that receive the placement of food products. Often, the inner region of the tray container is covered by attaching a freezable, microwaveable sealing film to the top of the sidewalls or to a flange area so that the food product contained therein is hermetically sealed.

[0004] To ensure proper cooking of the food product in the microwave, and to prevent the food package from bursting, many existing freezable, microwaveable food packages require the inclusion of a vent for the cooking or heating cycle. More specifically, a vent may be added to the sealing film so as to release heat and/or steam that may be generated while cooking or heating the food product in the microwave.

[0005] Some freezable, microwaveable food packages do not include a steam vent system, but instead rely on the user to create the vent by piercing a slot or hole into the sealing film prior to placing the food package into the microwave.

[0006] Other types of freezable, microwaveable food packages include built-in steam venting systems. For example, a food package may have built-in holes or slits on the sides or end seals of the sealing film that may be formed by mechanical apparatuses, such as cutters or punches. Additionally, some food packages may have vent systems in the form of micro-perforated zones or strips in the sealing film. In some instances, such slits or openings may be formed in a portion of a food package and is subsequently covered or closed by the addition of a laminate to the food package.

[0007] Some freezable, microwaveable food packages provide a built-in vent by scoring a line across most, if not all, the length of the sealing film of the food package to create a line where the film may tear during the cooking operation. For example, some food packages may use an approximately 6 inch (15 cm) long scored line across nearly the entire length of a freezable, microwaveable food package that is in the form of a pouch. Moreover, this scored line may extend from approximately one seam or edge to the opposite seam or edge of the package.

[0008] Reference to any prior art in the specification is not, and should not be taken as, an acknowledgment, or any form of suggestion, that this prior art forms part of the common general knowledge in Australia or any other jurisdiction or that this prior art could reasonably be expected to be ascertained, understood and regarded as relevant by a person skilled in the art.

20

BRIEF SUMMARY OF THE INVENTION

[0009] In a first aspect of the invention there is provided a method for providing a vent system in a heatable package comprising:

- a) scoring at least one vent pattern into a sealing film of the heatable package with a laser, especially chosen from the group of a 10.2 μ m wavelength CO₂ laser and a 10.6 μ m wavelength CO₂ laser, to form a weakened wall pattern, the at least one vent pattern having a weakened wall thickness of approximately 5 μ m to approximately 25 μ m, and a depth that does not perforate the sealing film, the at least one vent pattern having a vent pattern span that is the greater of the maximum length and width of the vent pattern;

25

30

b) sealing at least a portion of the sealing film to form a pouch, the pouch having an inner surface and an inner region, the inner region configured to receive a product, at least a portion of the inner surface being adjacent to the weakened wall portion;

c) sealing the inner region of the pouch to hermetically seal the product contained therein, the sealed inner region having an inner region span that is equal to the greater of the maximum length and width of the inner region, wherein each of the at least one vent pattern has a vent pattern span that is from 2% to 15%, preferably from 4% to 7%, of the size of the inner region span; and

d) generating a pressure in the inner region during heating, the inner surface adjacent to the weakened wall portion being directly exposed to the generated pressure.

[0010] In a second aspect of the invention, there is provided a heatable package comprising:

an inner region configured to receive a product,

a sealing film, the sealing film being comprised of at least one layer of a microwavable film adapted for use in heating a product, the sealing film having an outer surface and an inner surface, the inner region of the package being hermetically sealed by at least a portion of the sealing film; and

at least one vent pattern having a wall thickness of approximately $5\mu\text{m}$ to approximately $25\mu\text{m}$ scored into a portion of the outer surface of the sealing film to form at least one weakened wall pattern, the at least one vent pattern scored by a laser at a depth that does not perforate the sealing film, the inner surface adjacent to the at least one weakened wall pattern being directly exposed to pressure generated in the inner region.

[0011] Also disclosed herein is a heatable package having a multi-layered sealing film that has an inner surface and an outer surface, and which is configured to cover the inner portion of the package that contains a product. The inner portion also includes an inner portion span. A vent system comprised of a linear or non-linear vent pattern scored by a laser into the outer surface of the multi-layered sealing film at a depth that does not perforate the sealing film, and which creates a weakened wall

09 Jan 2014

2009257891

-5-

pattern. The weakened wall pattern extends down to at least an adjacent portion of the inner surface. According to certain embodiments, the vent pattern has a vent pattern span that may be from 1% to 100%. According to other embodiments, the vent pattern has a vent pattern that is a fraction of the size of the inner region span, such as, for example, a vent pattern that is 1% to 50% the size of the inner region span. Further, the inner surface of the sealing film that is adjacent to the weakened wall pattern is directly exposed to pressure generated inside the inner region during heating.

[0012] "Product" is broadly defined here to include any material that can generate pressure when heated, either by an external source or by an internal change of conditions.

[0013] As used herein, the term "comprise" and variations of the term, such as "comprising", "comprises" and "comprised", are not intended to exclude other additives, components, integers or steps.

Paragraph [0014] has been removed.

BRIEF DESCRIPTION OF SEVERAL VIEWS OF THE DRAWINGS

[0015] Figure 1 is a cross-sectional view of a sealing film for use with a vent system according to an embodiment of the present invention.

-6-

[0016] Figure 2 is a cross-sectional view of a portion of a steam vent system having a scored vent pattern and the resulting weakened wall pattern across a portion of a sealing film according to an embodiment of the present invention.

[0017] Figure 3 is a perspective view of a freezable, microwaveable pouch-shaped food package having vent patterns in the form of circles according to an embodiment of the present invention.

[0018] Figure 4 is a perspective view of a freezable, microwaveable pouch-shaped food package having vent patterns in the form of crosses according to an embodiment of the present invention.

[0019] Figure 5 is a sectional view taken along section line 5-5 of Figure 3 of a partially expanded freezable, microwaveable pouch-shaped food package having an opened vent according to an embodiment of the present invention.

[0020] Figure 6 is a perspective view of a food package in the form of a freezable, microwaveable tray container covered by a sealing film having a vent system according to an embodiment of the present invention.

[0021] The foregoing summary, as well as the following detailed description of certain embodiments of the present invention, will be better understood when read in conjunction with the appended drawings. For the purpose of illustrating the invention, certain embodiments are shown in the drawings. It should be understood, however, that the present invention is not limited to the arrangements and instrumentalities shown in the attached drawings or identified in this specification.

-7-

DETAILED DESCRIPTION OF THE INVENTION

[0022] Figure 1 is a cross-sectional view of a sealing film 100 for use with a vent system according to an embodiment of the present invention. The sealing film 100 may have at least two layers, for example a core layer 104 positioned adjacent to an inner, heat sealable layer 102. In the embodiment illustrated in Figure 1, the sealing film 100 may also include an outer skin layer 106 positioned adjacent to the core layer 104. Further, an outer protective layer 110 may be adhered, such as through the use of an adhesive 108, to the outer skin layer 106.

[0023] Each layer of the sealing film 100 may be constructed from a variety of different base materials. For example, each layer of film in the sealing film 100 may be made from the same or different base materials, including a thermoplastic polymer, polyolefin, polyethylene, polypropylene, propylene/ethylene copolymer, or propylene/alpha-olefin copolymer, along with derivatives thereof, among others. Examples of the adhesive 108 include, but are not limited to, polyurethane, epoxides, hot-melt ethylene vinyl acetate, hot melt polyamide, and hot-melt polyester. Further, the sealing film 100 may be manufactured using a variety of film processing techniques, for example by lamination and coextrusion, including blown film coextrusion and a cast film process, among others. Further, the thickness of the sealing film 100 may depend, at least in part, on the size of the food package to be made from, or to include, the film 100. For example, according to certain embodiments, the sealing film 100 may have a thickness from about 2 mils to about 5 mils (50 to about 130 microns). The sealing film 100 optionally can be constructed

-8-

to withstand freezing, followed by heating to a cooking or other processing temperature.

[0024] Figure 2 is a cross-sectional view of a portion of a steam vent system 202 having a scored vent pattern 204 and the resulting weakened wall pattern 114 across a portion of a sealing film 100 according to an embodiment of the present invention. As shown in Figure 2, the sealing film 100 may have an outer surface 116 and an inner surface 118.

[0025] According to certain embodiments, the vent pattern 204 may be created by a laser beam scoring at least one vent pattern 204 into the outer surface 116 of the sealing film 100. For example, the vent pattern 204 may be scored into the sealing film 100 using an approximately 10.2 μ m or 10.6 μ m wavelength CO₂ laser operated at about 20 watts to 200 watts. The laser can be scanned or otherwise moved related to the film 100, or vice versa, for example at 70 ft/min (0.36 m/sec). The vent pattern 204 can be scored into the sealing film 100 at a depth that does not perforate the sealing film 100. By not perforating the sealing film 100, the scored vent pattern 204 may allow the package 200 to be hermetically sealed, and thereby prevent or resist microorganisms or oxygen from entering into the package 200 through the vent pattern 204 that could contaminate or degrade the product contained therein. Further, the lack of perforations in the scored vent pattern 204 may prevent product contained within the package 200 from leaking out of the package 200 through the vent pattern 204.

-9-

[0026] Mechanically formed vent systems, such as those that cut, slit, or pierce the sealing film, typically rely on a subsequent lamination manufacturing step to cover openings in the sealing film created by such operations. In such operates, laminate is subsequently applied in an attempt to create a package that may be hermetically sealed. However, the use of a laser to score the package may remove the need for such a lamination procedure. More specifically, the laser, such as the approximately 10.2 μ m or 10.6 μ m wavelength CO₂ laser described above, may be operated to score the sealing film without cutting or piercing through the wall of the sealing film. And because such a laser may be operated so as to not create such openings, the sealing film may still be suitable for use in a hermetically sealed package without the need for the subsequent lamination procedure that may be associated with covering holes in mechanically formed vent systems.

[0027] The vent pattern 204 can define a weakened wall pattern 114 in the sealing film 100. For example, according to embodiments in which the sealing film 100 is a 3.5 mil (89 micron) laminate, the vent pattern 204 may be scored into the sealing film 100 to create a weakened wall pattern 114 that has a wall thickness of approximately 5 μ m to approximately 25 μ m.

[0028] Figures 3 and 4 are perspective views of a freezable, microwaveable pouch-shaped food package 200 having a vent system 202 comprising vent patterns 204, 206 in the form of circles and crosses, respectively, according to embodiments of the present invention. The food package 200 may be manufactured using conventional packaging equipment. For example, according to embodiments in

-10-

which the food package 200 is a pouch, vertical form fill and seal equipment or horizontal form fill and seal equipment may be used to form the food package 200. Typically, in the operation of such equipment, the sealing film 100 that is to be formed into the food package 200 is fed from a roll to the equipment where it is wrapped about a forming tube and a longitudinal heat seal is provided to form the fin seal 207, closing the sealing film 100 to form a tube. Thereafter, one end of the tube is closed and inner heat seal layers are heat sealed together to form one end of an inner region, which is then filled with a predetermined quantity of product. The filled food package 200 is then closed and the inner heat seal layers are heat sealed together at the open end to form a food product packaged in a hermetically sealed food package 200. As shown in Figures 3 and 4, the food package 200 may include end seals 205a, 205b, and a fin seal 207.

[0029] One can use a single scored line, which can be straight, curved, or a closed loop, to create a weakened wall pattern 114 forming the vent system 202. Alternatively, one can utilize two or more vent patterns such as 204, 206 that are scored into the outer surface 116 of the sealing film 100 by a laser or other means. For example, Figures 3 and 4 illustrate food packages 200 having a vent system 202 comprising at least one vent pattern, and have two vent patterns 204 or 206 per package, in the form of a circle or a cross, respectively. However, a variety of different shapes and patterns may be used to form the vent patterns 204, 206, for example closed loop patterns, such as a trapezoid, rectangle, square, triangle, oval,

circle, as well as other non-linear patterns, such as crosses, "I"-shaped patterns, and "T"-shaped patterns, along with combinations and variations thereof, among others.

[0030] By using a vent pattern having short dimensions, rather than a single long scored line, the size of the vent created by separation along the pattern may be controlled. For example, if a long scored line is used, the entire line may open, whereby the pressure in the food package may drop to an atmospheric level that prevents the food product from being cooked uniformly to a desired temperature, and which may then result in insufficient cooking or heating or cold spots in the cooked or heated food or other product. Alternatively, the scored line may not open, which may cause the food package to burst or delaminate, or cause contents to leak out of the seal. Another possible result is loss of the hot food product from the food package, which presents a safety hazard for the user.

[0031] The amount of steam generated during the heating or cooking of a product, and thus the amount of pressure needed to be released from the package 200 in order to maintain desired pressures and temperatures without bursting the package 200, depends on a variety of factors. For example, if the product to be heated or cooked is a frozen food product, the vent system 202 may be designed with considerations given to such factors, such as the food type, moisture content, the size and weight of food package 200, and anticipated microwave power, among other factors. Moreover, in such instances, the vent system 202 may be configured to allow for a heating or steam pressure of 0.25 to 2.0 psi to be maintained within the

-12-

package 200 so that the food product contained therein may be uniformly heated or cooked at a desired temperature, such as above 160° F.

[0032] The vent pattern such as 204, 206 may be sized to accommodate the various types and weights of food products that are packaged within the food package 200. For example, for a 12 ounce (340 g) frozen food product that is contained in an approximately 6.5 inch (17 cm) wide by 9 inch (23 cm) long food package 200, the vent system 202 may include two circular vent patterns 204 having a diameter of approximately 4mm to 20mm, or include two vent patterns 206 in the shape of crosses, wherein at least one and optionally both of the intersecting lines of the cross has a length of 4mm to 20mm.

[0033] The vent pattern 204, 206 can have a line thickness and/or depth that allows for the formation of the weakened wall pattern 114, while still allowing a hermetic seal to be formed and/or maintained about the packaged food product. Further, the line thickness and/or depth of the vent pattern 204, 206 can be such as to prevent the food package 200 from opening along at the weakened wall pattern 114 prior to, or too early during, the cooking or heating of the food package. Additionally, the line thickness and/or depth of the vent pattern 204, 206 can be sized to be large enough to allow at least a portion of the weakened wall pattern 114 to open during cooking or heating, as necessary so that undesirable excess pressure may be released from within the food package 200, but small enough to allow a desired pressure level to be maintained inside the food package 200. This can be accomplished, for example, by sizing the vent pattern 204, relative to the

-13-

desired heating conditions, so the pattern 204 opens to create a vent when the desired triggering pressure is generated in the package 200, and so steam or other vapor at the desired pressure is released through the vent at about the same rate as additional steam is formed.

[0034] According to certain embodiments, the vent pattern 204, 206 may have a wall thickness of approximately 5 μ m to approximately 25 μ m. Such a wall thickness for the vent patterns 204, 206 may also facilitate the generation of micro-voids or cracks in the weakened wall pattern 114 as the sealing film is expanded during heating.

[0035] Figure 5 is a sectional view taken along section line 5-5 of Figure 3 of a partially expanded freezable, microwaveable pouch-shaped food package 200 having opened vents 201a, 201b according to an embodiment of the present invention. As shown in Figure 5, the sealing film 100 may be oriented so that the food package 200 may include a first wall 220 and a second wall 222. The food package 200 may be placed within the microwave with the outer surface 116b of the second wall 222 facing in a generally upward direction. Accordingly, the food product 300 may be in the inner region 120 against at least a portion of the inner surface 118a of the first sidewall 220.

[0036] As previously mentioned, the vent patterns 204a, 204b may be scored into the sealing film 100 at a depth that does not puncture the sealing film 100. Further, because no secondary seals or other connections or attachments within or along the food package 200 shields the weakened wall pattern 114 from the pressure

-14-

generated in the inner region 120 during heating, the weakened wall pattern 114 is able to expand with the rest of the sealing film 200 during the cooking or heating cycle. Accordingly, the weakened wall pattern 114 may remain closed until the pressure within the inner region 120 of the food package 200 causes the sealing film 100 to expand to a size that tears or cracks at least a portion of the weakened wall pattern 114, and thereby opens at least a portion of one or more of the vents 201a, 201b. At least initially, this tearing may take the form of micro-voids or cracks along at least a portion of the weakened wall pattern 114, through which excess pressure may be released from the inner region of the food package. However, if the pressure level within the inner region 120 continues to rise, and the sealing film 100 continues to expand, the size and/or number of the cracks and micro-voids along the weakened wall pattern 114 may increase, thereby reducing the pressure in the inner region 120.

[0037] In some instances, the sealing film 100 may continue to expand until the size or number of micro-voids and/or cracks results in larger tears in at least sections of the weakened wall pattern 114. However, the size of the tear in the weakened wall pattern 114 is controlled, or limited, by the size of the vent pattern 204a, 204b. For example, in the embodiment illustrated in Figure 5, if the vent pattern 202a is a circle having an approximately 12 mm diameter, the largest vent 201a created by the tearing or separation along the weakened wall pattern 114 is generally circular in shape and has an approximately 12 mm diameter. By controlling or limiting the maximum size of the vent 201a generated about the

-15-

weakened wall pattern 114, the amount of pressure released through the vent(s) 201a, 201b is controlled, which allows the pressure and/or temperature within the inner region 120 to be maintained at a desirable level for heating.

[0038] Figure 6 is a perspective view of a food package 300 in the form of a freezable, microwaveable tray container 302 covered by a sealing film 100 having a vent system 202 according to an embodiment of the present invention. The tray container 302 may have a variety of different shapes, including rectangular, square, circular, oval, trapezoidal, and triangular, among others.

[0039] The tray container 302 illustrated in Figure 6 has a generally oval shape. The tray container 302 may include sidewalls 306 that define a recessed inner region 308. The inner region 308 may be comprised of at least one food compartment 310, 312 that is configured to receive a food product. The inner region 308 may be covered by a sealing film 100 that is attached to a top portion 311 of the tray container 302. For example, in the embodiment illustrated in Figure 6, an upper flange area 314 may be connected to, or part of, the sidewalls 308, and may provide a surface for attaching or sealing the sealing film 100 to the tray container 302. The sealing film 100 may be used in combination with the tray container 302 to hermetically seal the food product contained in the inner region 308.

[0040] The vent system 202 used with a food package 300 having a tray container 300 may be similar to that previously discussed above for the pouch-shaped food package 200. Moreover, the vent system 202 may include at least one vent pattern 206 that has been scored into the sealing film 100 to create a weakened

-16-

wall pattern 114. For example, as shown in Figure 6, the vent system 202 may include two vent patterns that are each cross-shaped.

[0041] Further, each vent pattern 204, 206 has a vent pattern span, which is the larger of the maximum width and length of the vent pattern 204, 206. The inner region 120, 308 has an inner region span, which is the larger of the maximum width and length of the inner region 120, 308. For example, if the maximum length of the inner region 120, 308 of the pouch-shaped or tray-container food package 200, 300, as labeled in Figures 4 and 6 as " l_1 ", is 9 inches, and the maximum width of the inner region 120, 308 of 6.5 inches (17 cm), as labeled " w_1 ", then the size of the inner region span is the maximum length, i.e. 9 inches (23 cm). Conversely, if the maximum width is 9 inches (23 cm), and the maximum length is 6.5 (17 cm), then the size of the inner region span is equal to the maximum width, i.e. 9 inches (23 cm). However, if the maximum width and length of the inner region 120, 308 are equal, then either may be used for purposes of determining the size of the inner region span. Similarly, if the maximum length and width of the vent pattern 204, 206 are equal (as indicated in Figure 4 as " l_2 " and " w_2 " respectively), then either size may be used for purposes of determining the size of the vent pattern span.

[0042] The vent pattern span for each vent pattern 204, 206 of the present invention may be sized to be a fraction of the inner region span. For example, according to certain embodiments, if the inner region span is 9 inches (23 cm), and each vent pattern has an individual vent pattern span of 12 mm, such as a vent pattern 204 being a circle having a diameter of 12 mm, or a cross shaped vent

-17-

pattern 206 comprised of two intersecting lines, the longest, or both lines, having a length of 12 mm, vent pattern span is approximately 5% of the size of the inner region span. However, the difference between the size of the inner region span and the vent pattern span may depend on a number of different factors, including the type of food product being packaged and the size of the food package 200, 300. For example, according to certain embodiments of the present invention, each individual vent pattern span may be from 1% to 100% of the size of the inner region span. According to some embodiments, each vent pattern may have a vent pattern span that is from 1% to 50% of the size of the inner region span. According to other embodiments, each vent pattern may have a vent pattern span that is from 2% to 15% of the size of the inner region span. According to other embodiments, each vent pattern may have a vent pattern span that is from 4% to 8% of the size of the inner region span. Further, the vent system 202, 304 of the present invention may have more than one vent pattern 204, 206, and each vent pattern may have the same or a different vent pattern span.

[0043] Example 1: Pouch-Shaped Food Package Having Circular Vent Scoring Patterns

[0044] An approximately 6.5 inch (17 cm) wide by 9 inch (23 cm) long food package was formed in the shape of a pouch using Pliant's freezable/microwaveable Steam Quick™ laminate. The food package included two end seals, each having a width of approximately 0.4 cm to approximately 1.2 cm, which allowed for an inner region span of approximately 14.6 cm to approximately 16.2 cm. The food package included two vent scoring patterns in the form of circles having approximately 12 mm

-18-

diameters. The vent patterns were scored into the laminate with the use of a 10.2 μ m wavelength CO₂ laser at about 40 watts of power and scanned at about 70 ft/min (0.36 m/sec), and did not perforate the laminate. The inner region of the pouch was filled with 12 ounce (340 g) of frozen broccoli cuts and manually hand sealed by a heat sealer. The food package was then stored in a freezer for 24 hours at -5° F (-21° C).

[0045] Upon removing the food package from the freezer, the food package was placed in a microwave, and underwent 6 minutes of cook time at approximately 1200 watts of power. One pressure probe and four temperature probes were inserted into the pouch before, during, and after the cook cycle. The food package was also observed expanding during the cook cycle, along with the weakened wall along the two scored vent patterns opening accordingly to release heat and steam during the cook cycle. The maximum pressure detected by the pressure probe in the microwave testing was 0.98 psi (0.07 bar). The maximum temperature reached was 229.4° F (110° C). The food temperature was 193.5° F (90° C). The food was also observed to have been cooked uniformly.

[0046] Example 2: Pouch-Shaped Food Package Having Cross Vent Scoring Patterns

[0047] An approximately 6.5 inch (17 cm) wide by 9 inch (23 cm) long food package was formed in the shape of a pouch using Pliant's freezable/microwaveable Steam Quick™ laminate. The food package included two end seals, each having a width of approximately 0.4 cm to approximately 1.2 cm, which allowed for an inner region span of approximately 14.6 cm to approximately 16.2 cm. The food package

-19-

included two vent scoring patterns in the form of crosses, with the length of each line in the cross being approximately 12 mm long. The vent patterns were scored into the laminate with the use of a 10.2 μ m wavelength CO₂ laser at about 40 watts of power and scanned at about 70 ft/min (0.36 m/sec), and did not perforate the laminate. The inner region of the pouch was filled with 12 ounce (340 g) of frozen broccoli cuts and manually hand sealed by a heat sealer. The food package was then stored in a freezer for 24 hours at -5° F (-21° C).

[0048] Upon removing the food package from the freezer, the food package was placed in a microwave, and underwent 6 minutes of cook time at approximately 1200 watts of power. One pressure probe and four temperature probes were inserted into the pouch before, during, and after the cook cycle. The food package was also observed expanding during the cook cycle, along with the weakened wall along the two scored vent patterns opening accordingly to release heat and steam during the cook cycle. The maximum pressure detected by the pressure probe in the microwave testing was 1.3 psi (0.09 bar). The maximum temperature reached was 219.4° F (104° C). The food temperature measured was 192.3° F (89° C). The food was also observed to have been cooked uniformly.

[0049] While the invention has been described with reference to certain embodiments, it will be understood by those skilled in the art that various changes may be made and equivalents may be substituted without departing from the scope of the invention. In addition, many modifications may be made to adapt a particular situation or material to the teachings of the invention without departing from its

-20-

scope. Therefore, it is intended that the invention not be limited to the particular embodiment disclosed, but that the invention will include all embodiments falling within the scope of the appended claims. Further, at least some of the numerical ranges stated above are not necessarily critical.

THE CLAIMS DEFINING THE INVENTION ARE AS FOLLOWS:

1. A method for providing a vent system in a heatable package comprising:
 - a) scoring at least one vent pattern into a sealing film of the heatable package with a laser, especially chosen from the group of a 10.2 μ m wavelength CO₂ laser and a 10.6 μ m wavelength CO₂ laser, to form a weakened wall pattern, the at least one vent pattern having a wall thickness of approximately 5 μ m to approximately 25 μ m and a depth that does not perforate the sealing film, the at least one vent pattern having a vent pattern span that is the greater of the maximum length and width of the at least one vent pattern;
 - b) sealing at least a portion of the sealing film to form a pouch, the pouch having an inner surface and an inner region, the inner region configured to receive a product, at least a portion of the inner surface being adjacent to the weakened wall portion;
 - c) sealing the inner region of the pouch to hermetically seal the product contained therein, the sealed inner region having an inner region span that is equal to the greater of the maximum length and width of the inner region, wherein each of the at least one vent pattern has a vent pattern span that is from 2% to 15% of the size of the inner region span; and
 - d) generating a pressure in the inner region during heating, the inner surface adjacent to the weakened wall portion being directly exposed to the generated pressure.

20

2. The method according to claim 1, wherein each of the at least one vent pattern has a vent pattern span that is from 4% to 8% of the size of the inner region span.

25

3. The method according to any one of claims 1 or 2, wherein the method further comprises a step i) of providing a sealing film carried out before step a) which

sealing film comprises an outer protective layer, an adhesive layer, a core layer and an outer skin layer.

4. The method according to any one of claims 1 to 3, further comprising a step ii) of freezing carried out before the step d).

5. The method according to claim 4, further comprising step iii) of heating the frozen pouch obtained after the freezing step.

6. The method according to any one of the preceding claims, wherein the CO₂ laser moves relative to the sealing film at a rate of about 70 feet per minute (0.36 metres per second), said laser being operated at between 20 and 200 W.

7. The method according to any one of the preceding claims, wherein the vent pattern span is 1% to 100% of the inner region span.

8. The method according to any one of the preceding claims, wherein the vent pattern span is 1 to 50% of the inner region span.

9. The method according to any one of the preceding claims, wherein the at least one vent pattern is generally circular in shape and has a diameter of about 4mm to 20mm.

10. The method according to any one of claims 1 to 8, wherein the at least one vent pattern is a cross that is comprised of at least one intersecting line having a length of about 4mm to 20mm.

11. A heatable package comprising:
an inner region configured to receive a product;

a sealing film, the sealing film being comprised of at least one layer of a microwavable film adapted for use in heating a product, the sealing film having an outer

surface and an inner surface, the inner region of the package being hermetically sealed by at least a portion of the sealing film; and

at least one vent pattern having a wall thickness of approximately $5\mu\text{m}$ to approximately $25\mu\text{m}$ scored into a portion of the outer surface of the sealing film to form at least one weakened wall pattern, the at least one vent pattern scored by a laser at a depth that does not perforate the sealing film, the inner surface adjacent to the at least one weakened wall pattern being directly exposed to pressure generated in the inner region.

12. The heatable package of claim 11, wherein the inner region has an inner region span that is equal to the greater of the maximum width and length of the inner region, the at least one vent pattern having a vent pattern span that is the greater of the maximum length and width of the at least one vent pattern, and wherein each of the at least one vent pattern has a vent pattern span that is from 1% to 50% of the size of the inner region span.

13. The heatable package of any one of claims 11 or 12, wherein each of the at least one vent pattern has a vent pattern span that is from 2% to 15% of the size of the inner region span.

14. The heatable package of any one of claims 11 to 13, wherein each of the at least one vent pattern has a vent pattern span that is 4% to 10% of the size of the inner region span.

15. The heatable package of any one of claims 11 to 14, wherein the wall thickness of the weakened wall pattern is $5\mu\text{m}$ to approximately $25\mu\text{m}$.

16. The heatable package of any one of claims 11 to 15, wherein the at least one vent pattern is a closed loop.

17. The heatable package of any one of claims 11 to 15, wherein the at least one vent pattern has a generally circular shape with a diameter of about 4mm to 20mm.

2009257891 09 Jan 2014

18. The heatable package of any one of claims 11 to 15, wherein the at least one vent pattern is a cross that is comprised of at least one intersecting line having a length of about 4mm to 20mm.

1/4

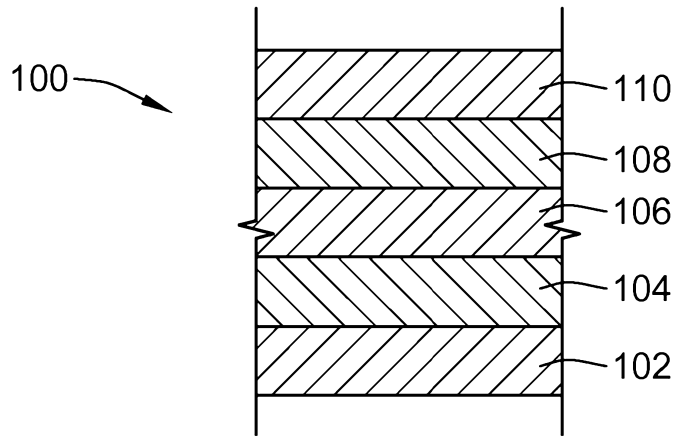

FIG. 1

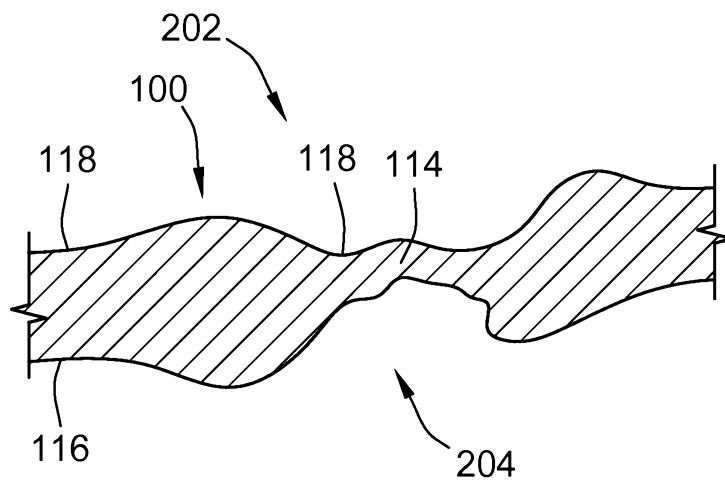

FIG. 2

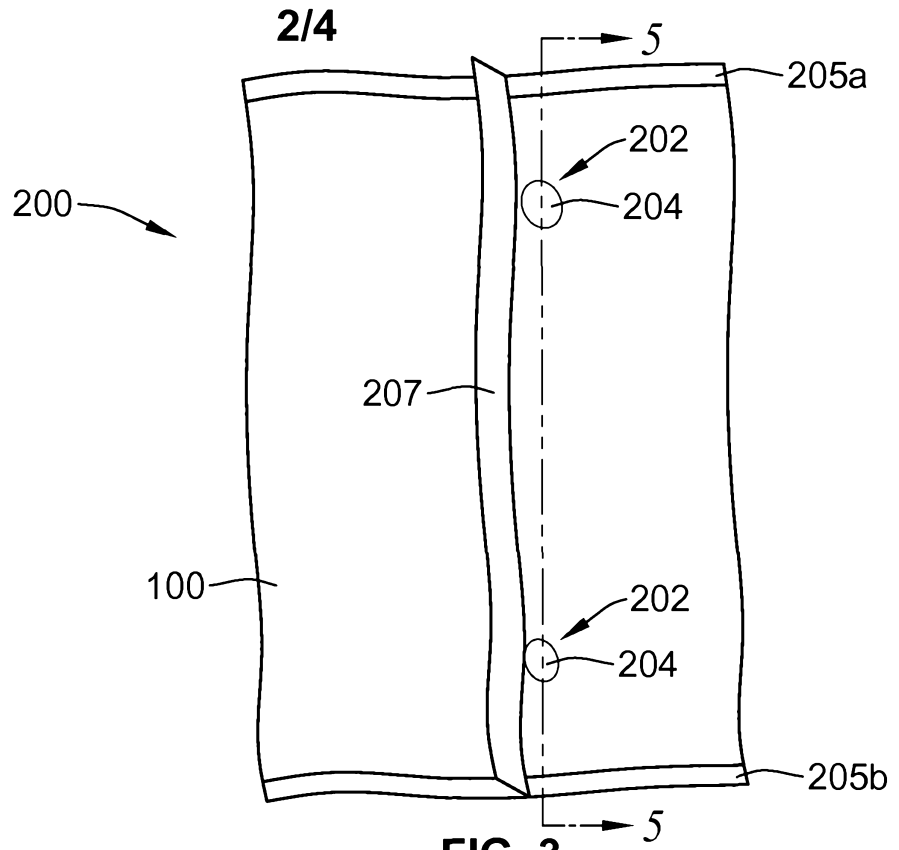

FIG. 3

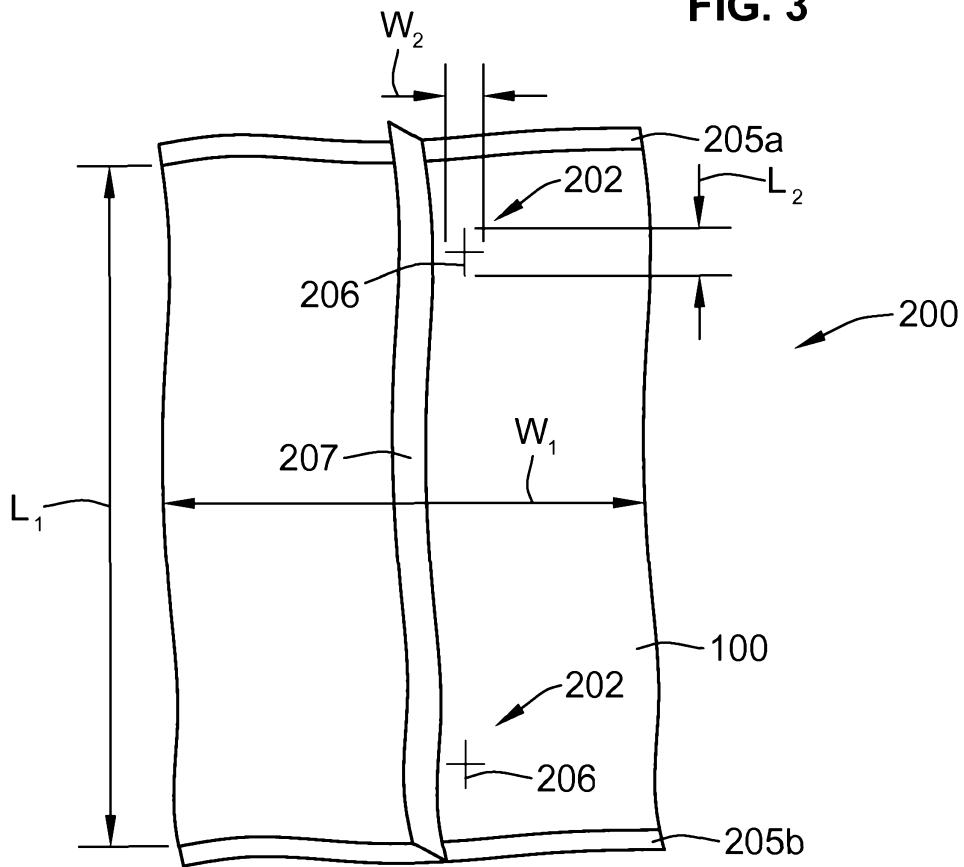

FIG. 4

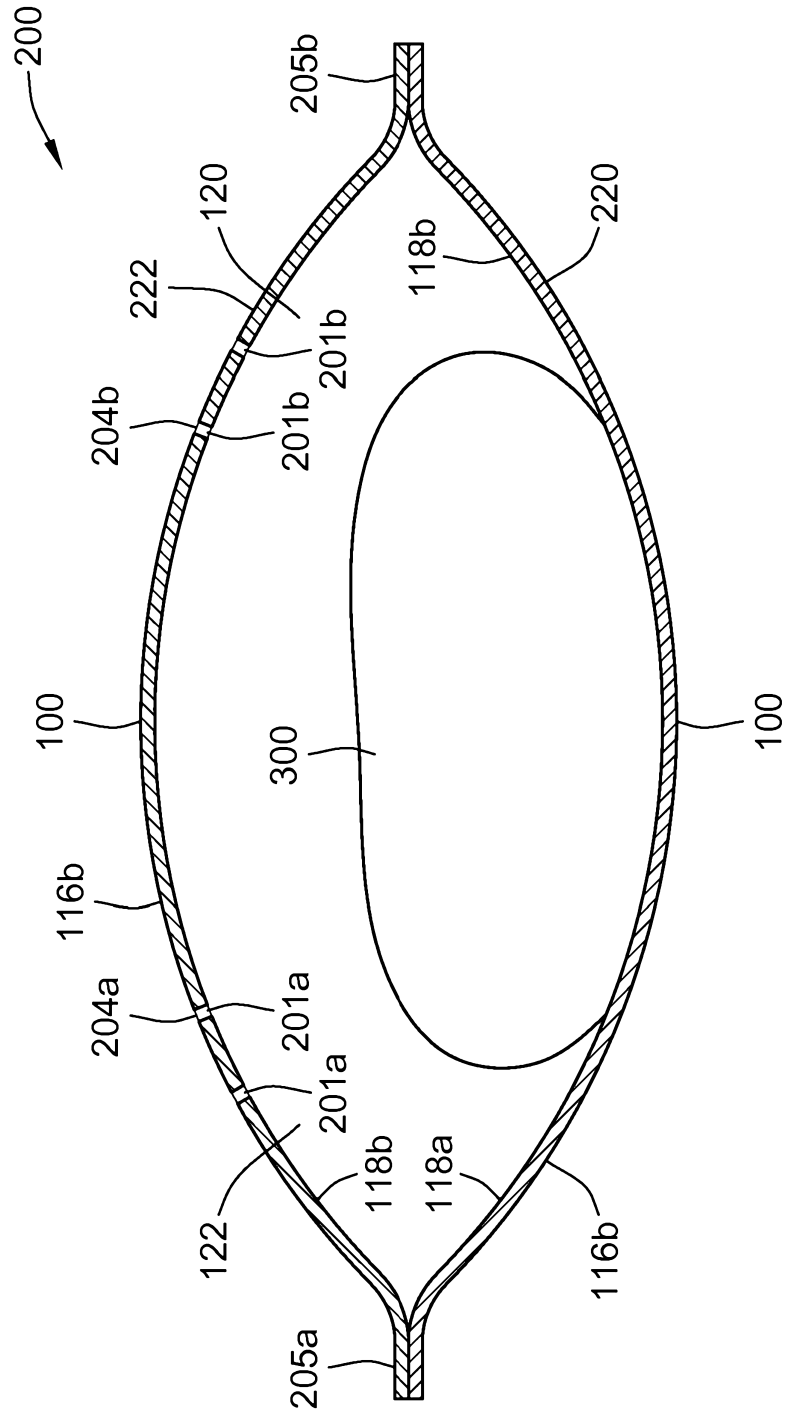

FIG. 5

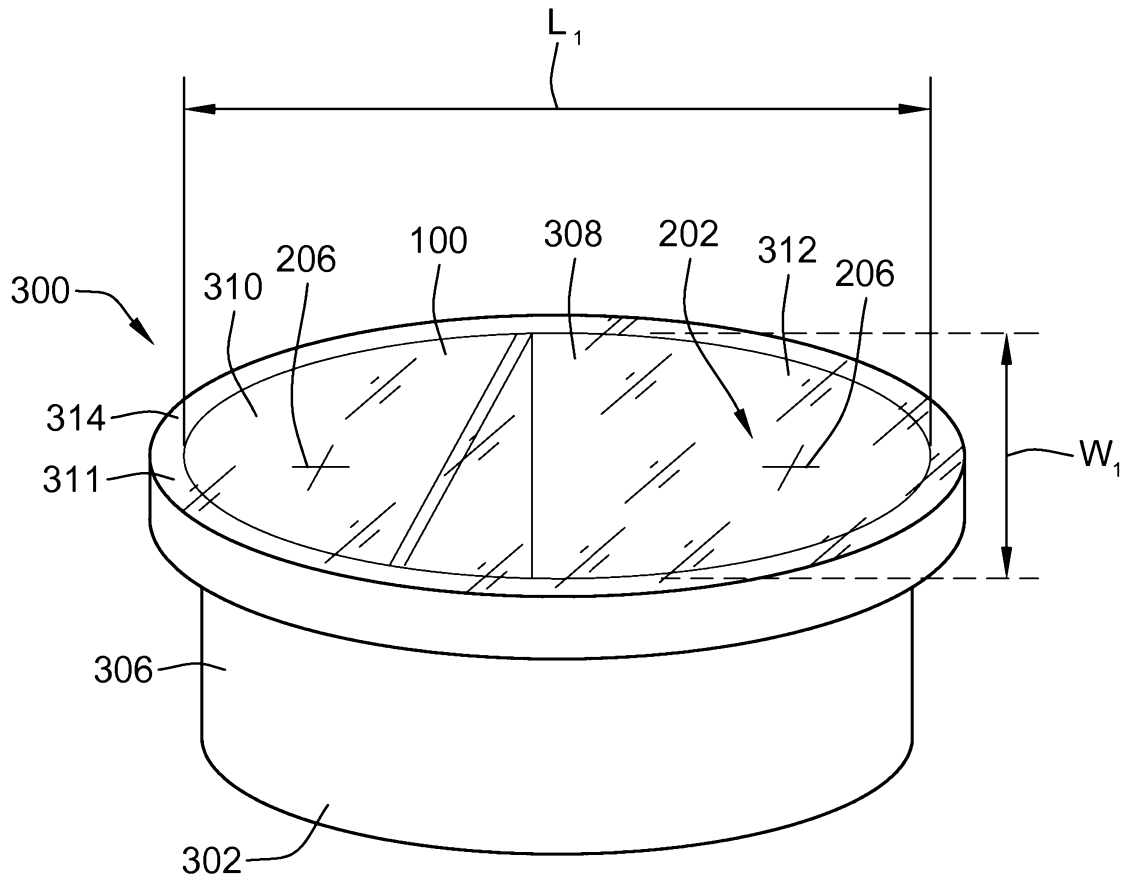

FIG. 6