



US00D977526S

(12) **United States Design Patent**  
**Vintzel**

(10) **Patent No.:** **US D977,526 S**

(45) **Date of Patent:** **\*\* Feb. 7, 2023**

(54) **AIR COMPRESSOR**

- (71) Applicant: **Harbor Freight Tools USA, Inc.**,  
Calabasas, CA (US)
- (72) Inventor: **James Constantine Vintzel**, Jackson,  
TN (US)
- (73) Assignee: **HARBOR FREIGHT TOOLS USA,**  
**INC.**, Calabasas, CA (US)
- (\*\*) Term: **15 Years**

- (21) Appl. No.: **29/785,297**
- (22) Filed: **May 25, 2021**
- (51) **LOC (14) Cl.** ..... **15-02**
- (52) **U.S. Cl.**  
USPC ..... **D15/9**
- (58) **Field of Classification Search**  
USPC ..... D13/103, 112; D15/7-9  
CPC .. E03B 5/00; F04B 41/02; F04B 41/06; F04B  
35/04; F04B 35/06; F04B 25/00; F04B  
17/06; F04B 17/03; F04B 53/18; F04B  
23/00; F04B 41/00; F04C 2210/221;  
F04C 2240/30  
See application file for complete search history.

(56) **References Cited**  
U.S. PATENT DOCUMENTS

D579,462	S	*	10/2008	Leasure	.....	D15/7
D666,167	S	*	8/2012	Pietzsch	.....	D14/196
D678,339	S	*	3/2013	Hughes	.....	D15/7
D902,260	S	*	11/2020	Vintzel	.....	D15/7
D917,569	S	*	4/2021	Youngblutt	.....	D15/7
D962,293	S	*	8/2022	Hu	.....	D15/7
2012/0241014	A1	*	9/2012	Wise	.....	F04B 23/02 137/13

OTHER PUBLICATIONS

Harbor Freight, FORTRESS 10 Gallon 175 PSI Ultra Quiet Horizontal Air Compressor, (first available Nov. 30, 2021), Amazon.com, URL:<<https://www.amazon.com/HFT-FORTRESS-Gallon-Horizontal-Compressor/dp/B09MSM7SDC>> (Year: 2021).\*  
The After Work Garage, "Tool Review Fortress 10 Gallon Ultra Quiet Air Compressor from Harbor Freight", (posted on Dec. 13, 2020), YouTube.com, URL:<<https://www.youtube.com/watch?v=O7fgZB2QGeU>> (Year: 2020).\*

\* cited by examiner

*Primary Examiner* — Calvin E Vansant  
*Assistant Examiner* — Mark T. Philipps  
(74) *Attorney, Agent, or Firm* — McAndrews Held & Malloy, Ltd.

(57) **CLAIM**

The ornamental design for an air compressor, as shown and described.

**DESCRIPTION**

FIG. 1 is a top and front perspective view of an air compressor showing my new design;  
FIG. 2 is a front elevation view thereof;  
FIG. 3 is a rear elevation thereof;  
FIG. 4 is a right side elevation view thereof;  
FIG. 5 is a left side elevation view thereof;  
FIG. 6 is a top plan view thereof;  
FIG. 7 is a bottom plan view thereof; and,  
FIG. 8 is a top and rear perspective view thereof.  
The dashed broken lines in the figures illustrate portions of the air compressor that form no part of the claimed design.

**1 Claim, 8 Drawing Sheets**

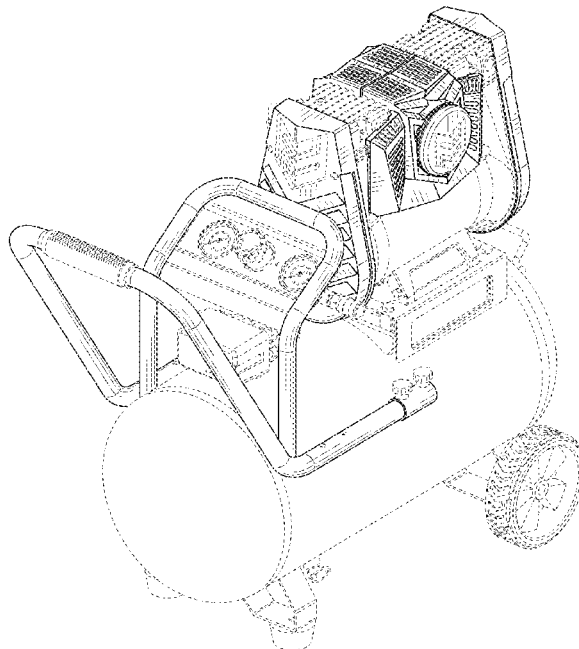

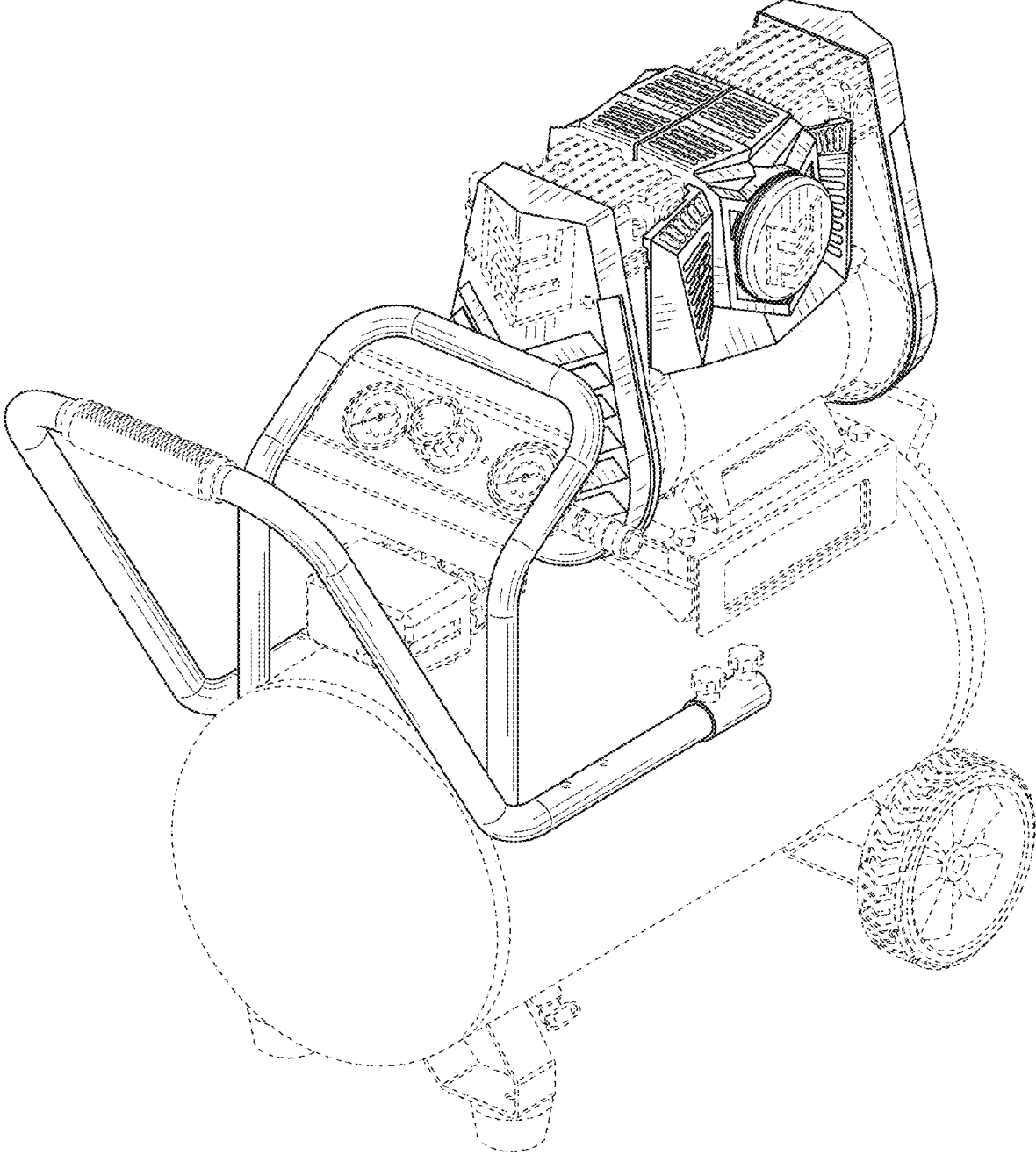

FIG. 1

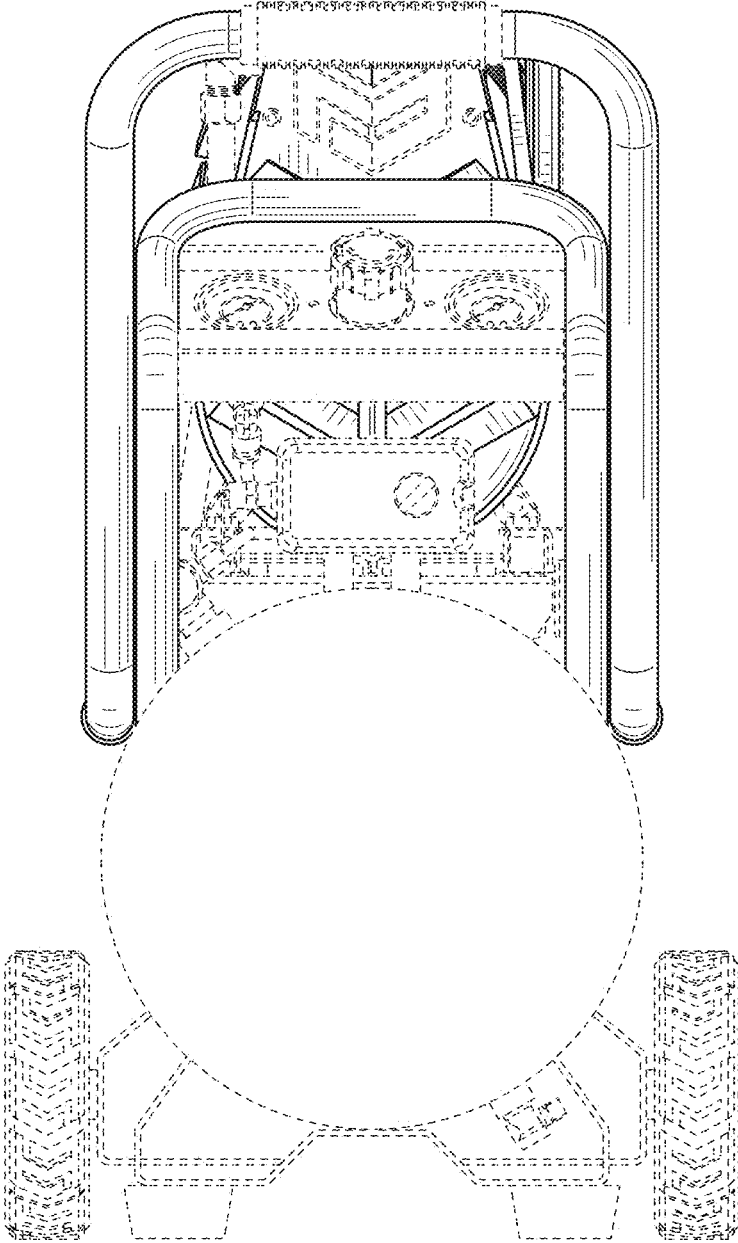

FIG. 2

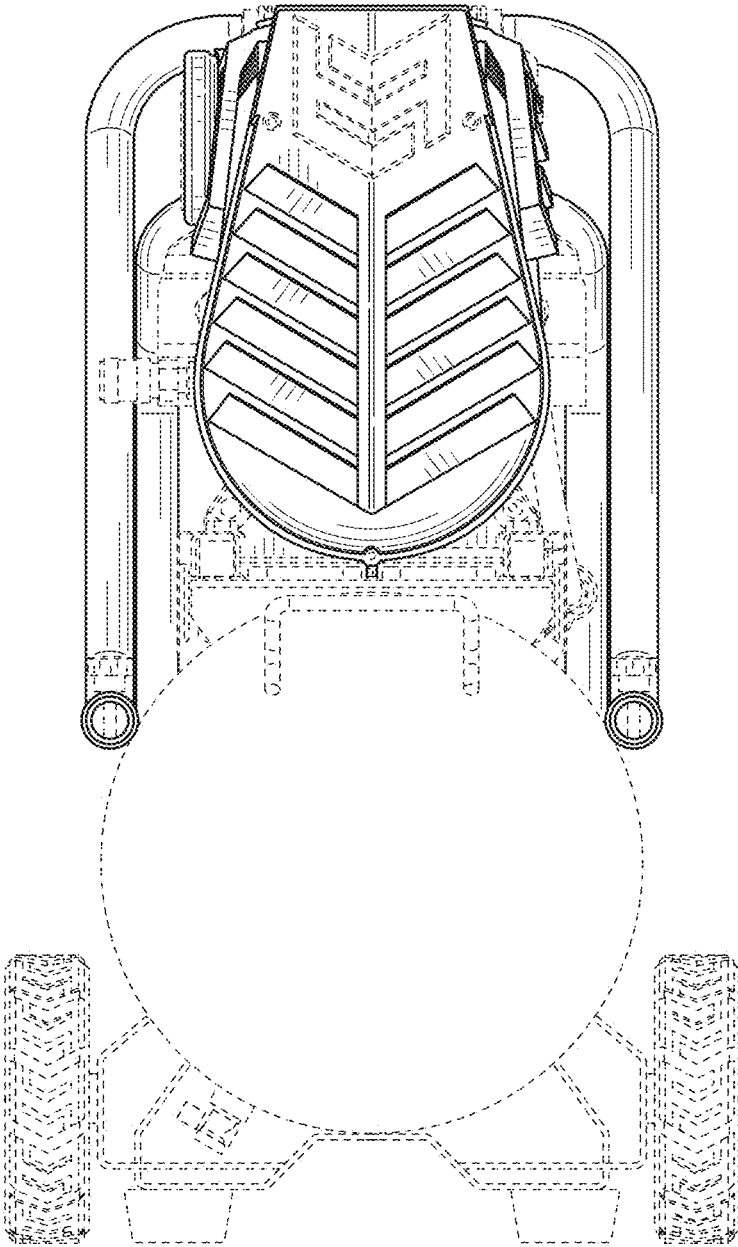

FIG. 3

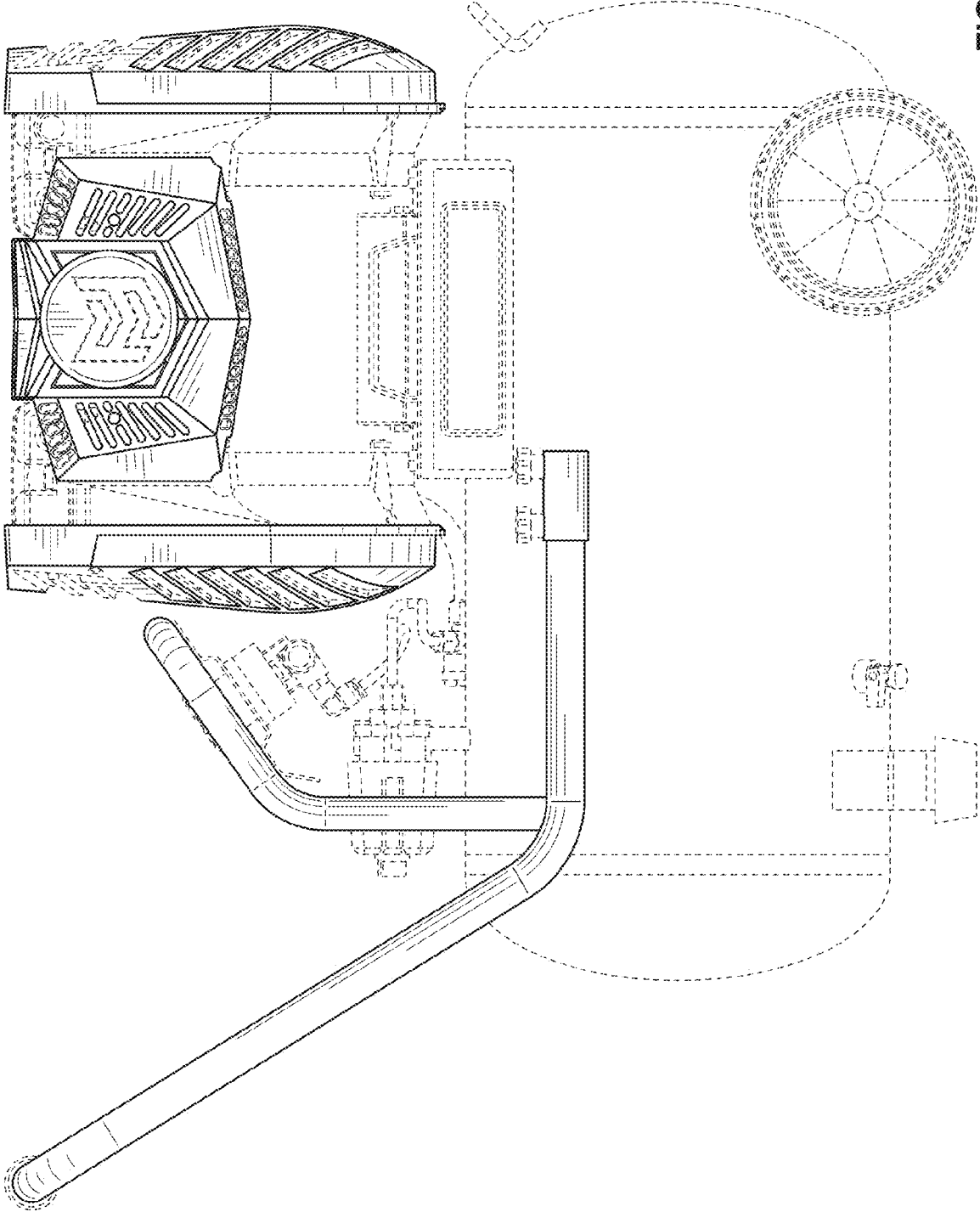

FIG. 4

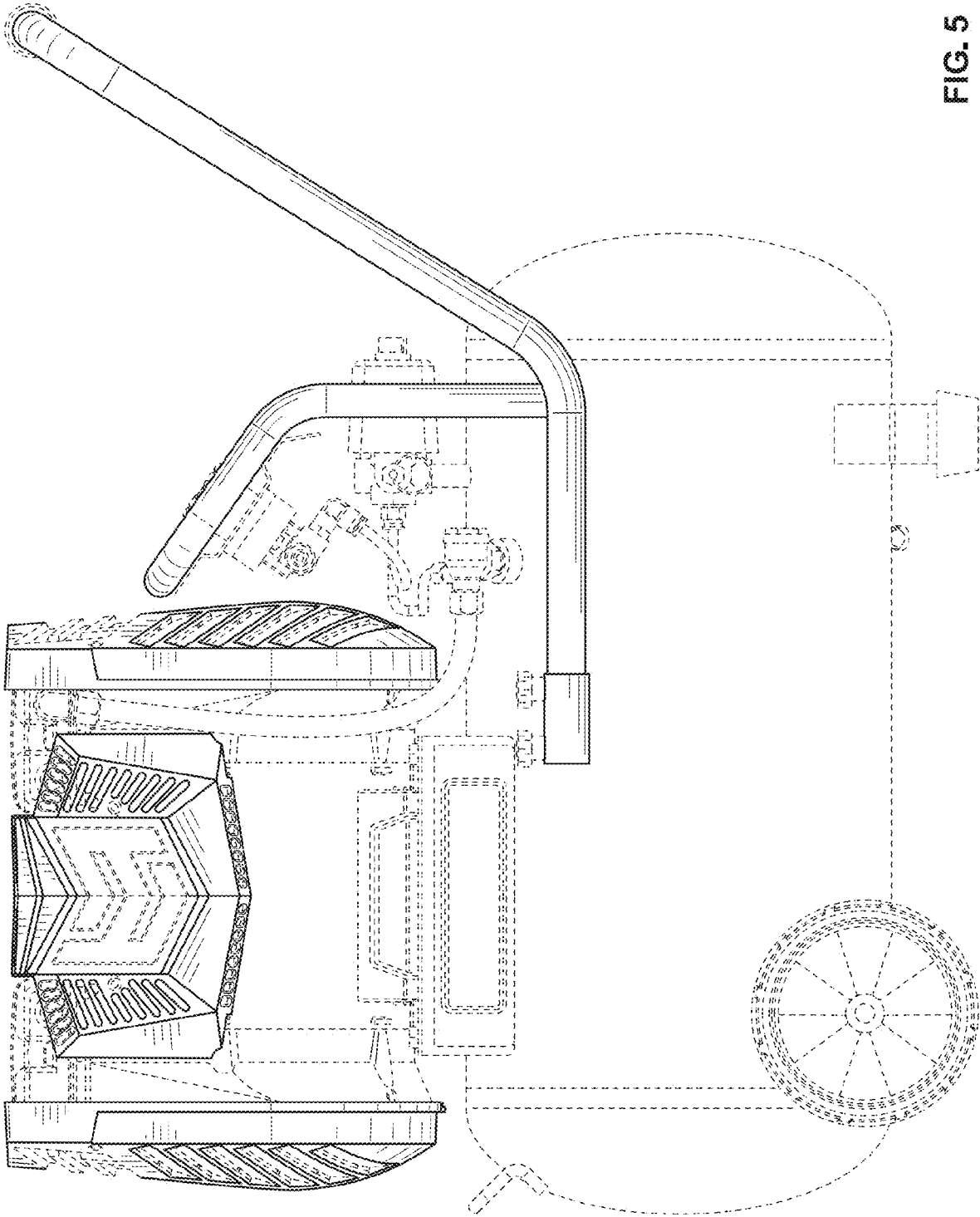

FIG. 5

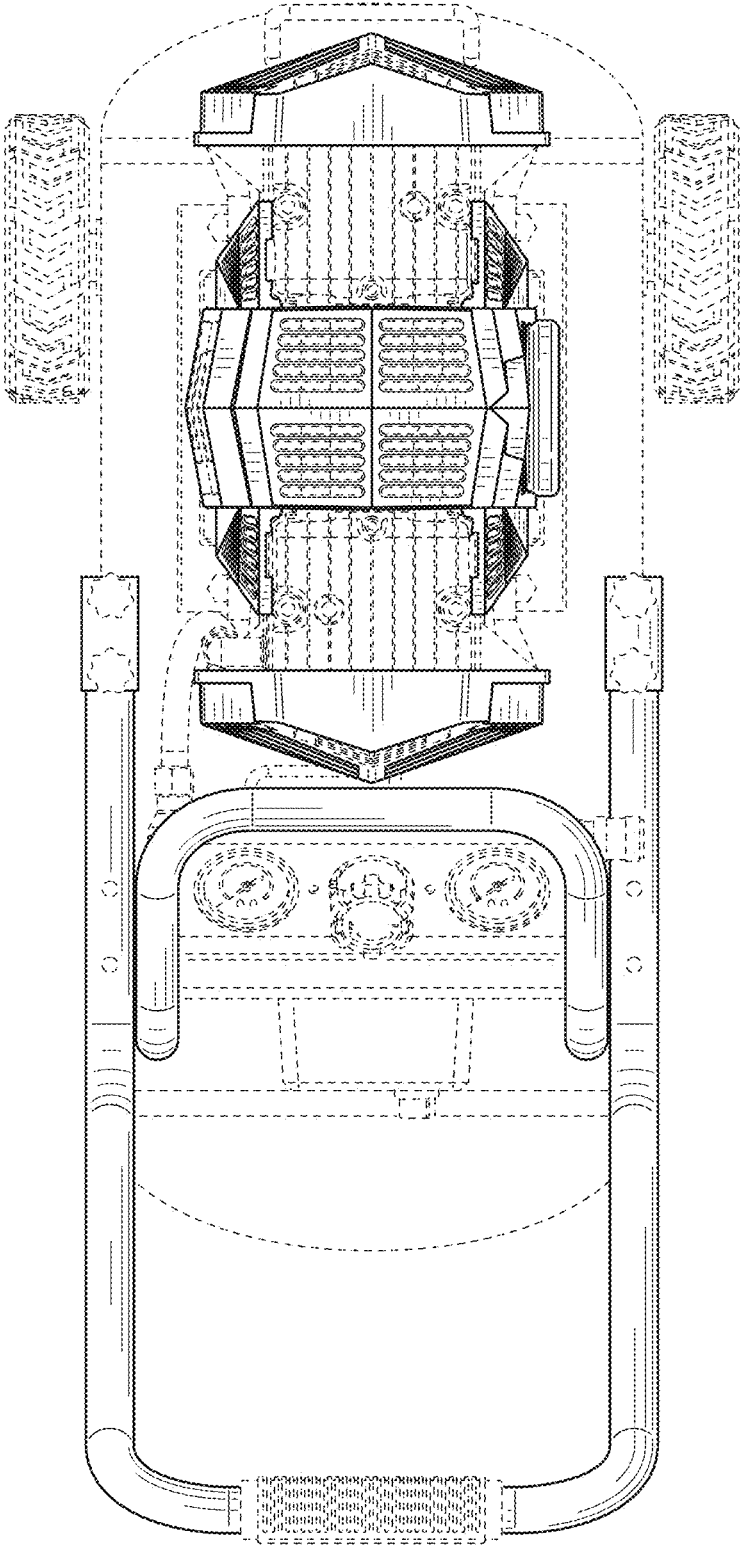

FIG. 6

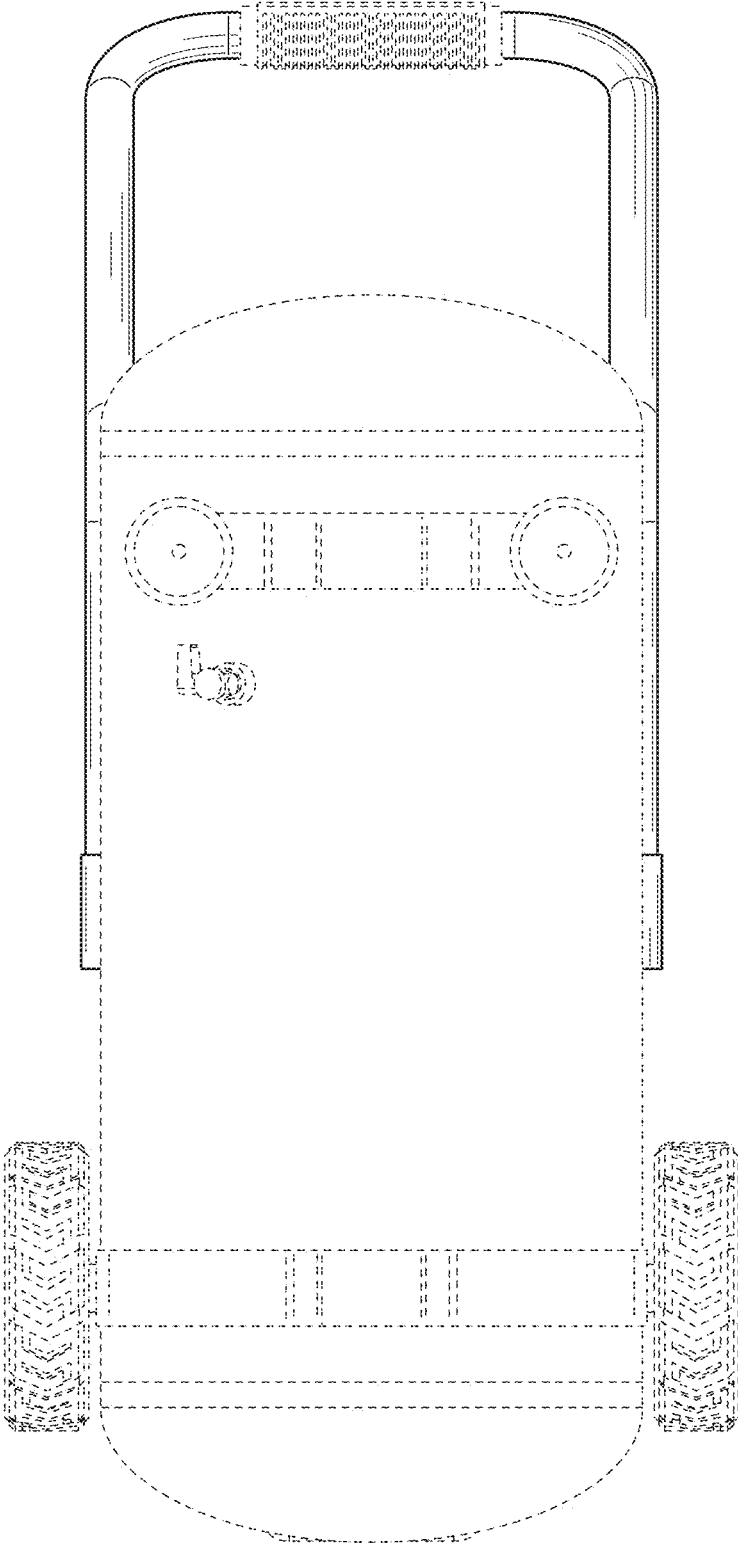

FIG. 7



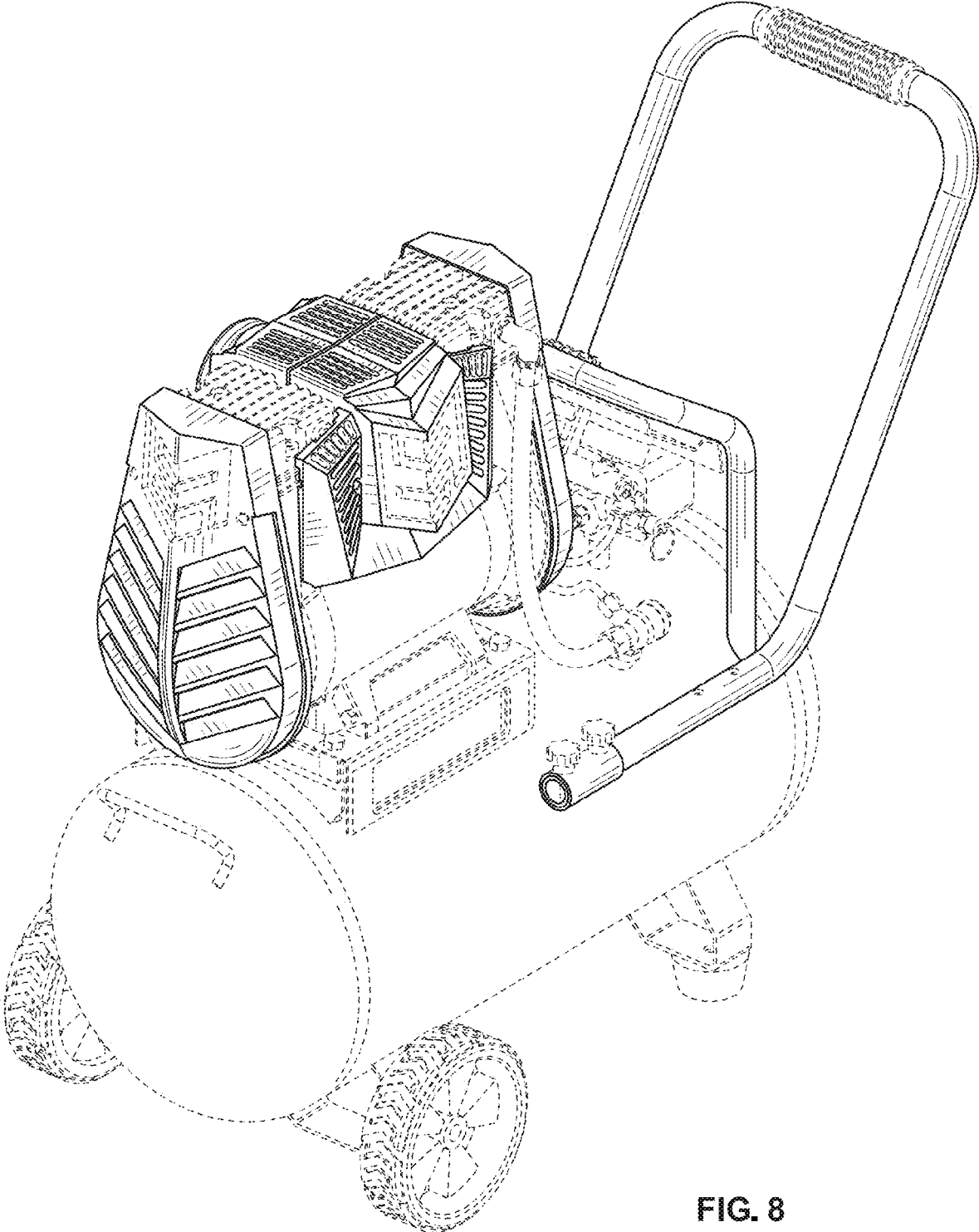

FIG. 8