



US00D845429S

(12) **United States Design Patent**
Rocha et al.

(10) **Patent No.:** **US D845,429 S**
(45) **Date of Patent:** **** Apr. 9, 2019**

(54) **INSECT TRAP HOUSING**

OTHER PUBLICATIONS

(71) Applicant: **Dynamic Solutions Worldwide, LLC**,
Milwaukee, WI (US)

Design U.S. Appl. No. 29/570,815 for "Insect Trap Housing"; filed Jul. 12, 2016; 22 pages.

(72) Inventors: **Juan J. Rocha**, Lake Forest, IL (US);
Robert A. Seaton, Verona, WI (US)

Design U.S. Appl. No. 29/611,062 for "Insect Trap Housing"; filed Jul. 18, 2017; 21 pages.

Design U.S. Appl. No. 29/608,946 for "Insect Trap Housing"; filed Jun. 27, 2017; 21 pages.

(73) Assignee: **Dynamic Solutions Worldwide, LLC**,
Milwaukee, WI (US)

* cited by examiner

(**) Term: **15 Years**

Primary Examiner — Catherine R Oliver-Garcia

(74) *Attorney, Agent, or Firm* — Boyle Fredrickson S.C.

(21) Appl. No.: **29/622,111**

(57) **CLAIM**

The ornamental design for an insect trap housing, substantially as shown and described.

(22) Filed: **Oct. 13, 2017**

(51) **LOC (11) Cl.** **22-06**

DESCRIPTION

(52) **U.S. Cl.**

USPC **D22/122**

(58) **Field of Classification Search**

USPC D22/119–124; D26/37, 40; 43/107,
43/112–113, 121–122, 124, 131, 132.1;
362/179; 431/253

CPC A01M 1/14; A01M 1/2011; A01M 1/2016;
A01M 2200/011; A01M 2200/012

See application file for complete search history.

FIG. 1 is a front, right side isometric view of an insect trap housing according to the present invention;

FIG. 2 is a front elevation view of the insect trap housing of FIG. 1 with a light bulb installed within the housing;

FIG. 3 is a rear elevation view of the insect trap housing of FIG. 1 with a light bulb installed within the housing;

FIG. 4 is a left side elevation view of the insect trap housing of FIG. 1 with a light bulb installed within the housing;

FIG. 5 is a right side elevation view of the insect trap housing of FIG. 1 with a light bulb installed within the housing;

FIG. 6 is a top plan view of the insect trap housing of FIG. 1; and,

FIG. 7 is a bottom plan view of the insect trap housing of FIG. 1.

The broken lines are for illustrative purposes and represent environmental structure and unclaimed portions of the invention and therefore form no part of the claimed design.

(56) **References Cited**

U.S. PATENT DOCUMENTS

3,864,867	A *	2/1975	Dry	A01M 1/14 43/131
4,603,505	A *	8/1986	Millard	A01M 1/04 362/179
4,785,573	A *	11/1988	Millard	A01M 1/04 362/179
D612,447	S *	3/2010	Galili	D22/123
D819,773	S *	6/2018	Rocha	D22/122

1 Claim, 7 Drawing Sheets

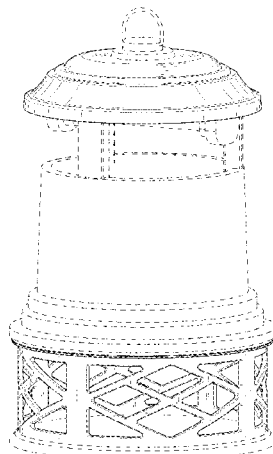

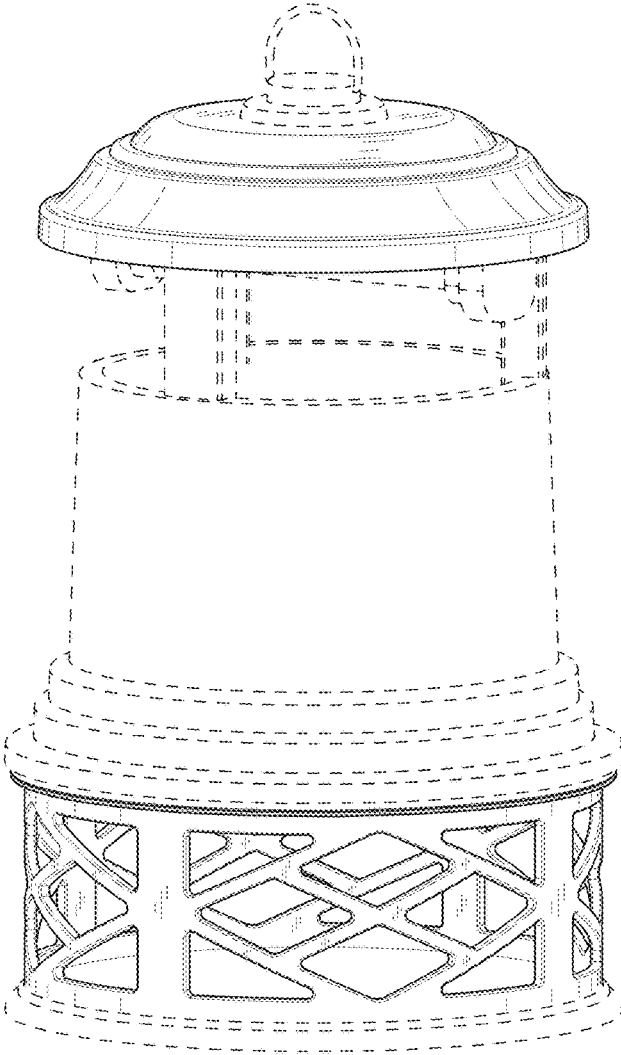

FIG. 1

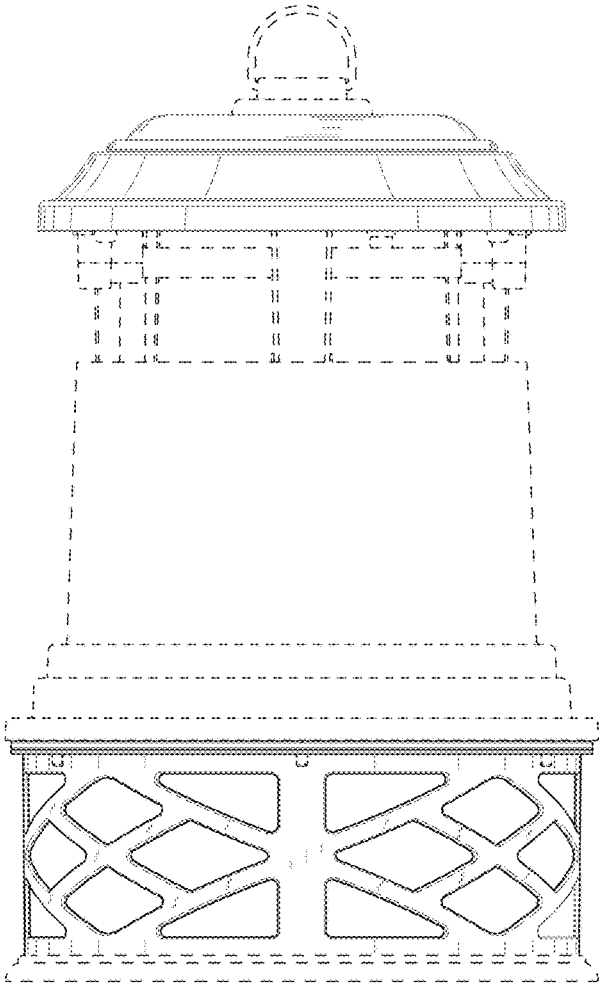

FIG. 2

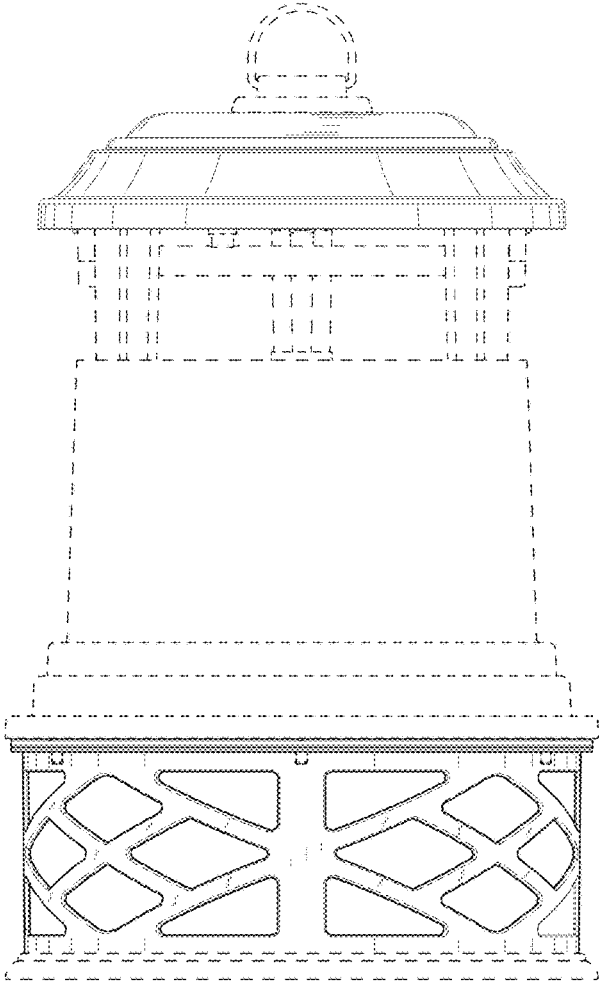

FIG. 3

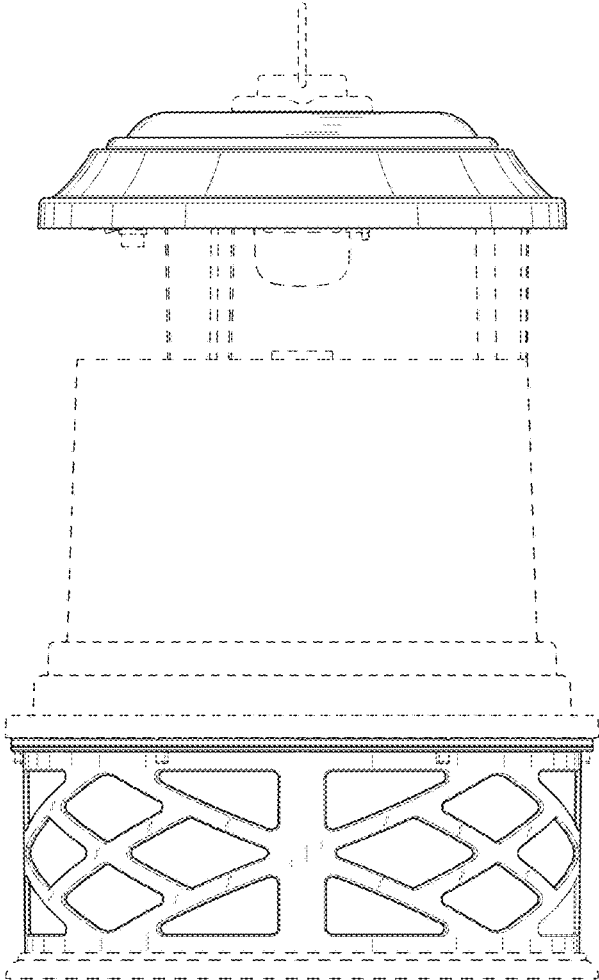

FIG. 4

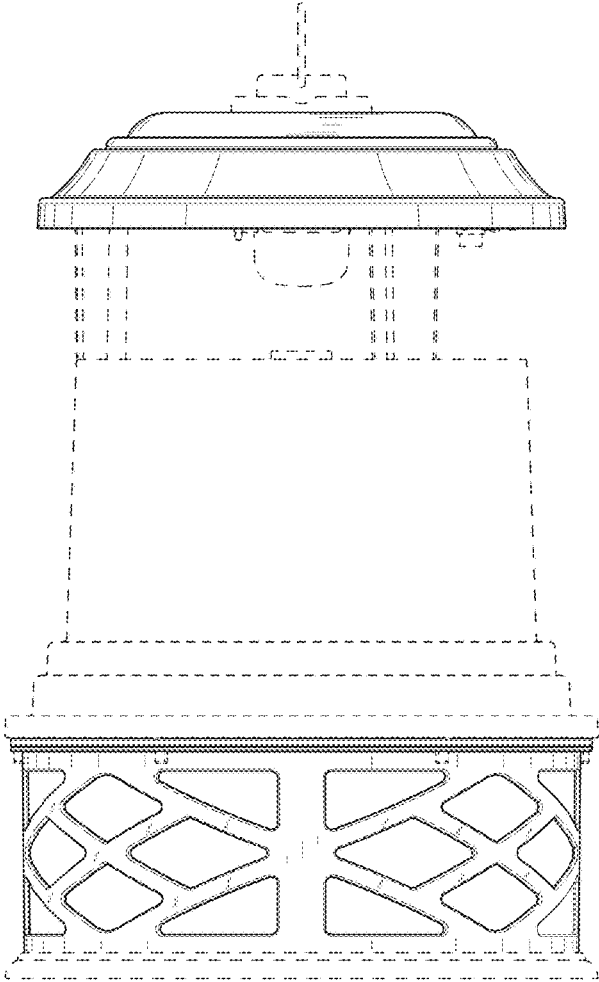

FIG. 5



FIG. 6

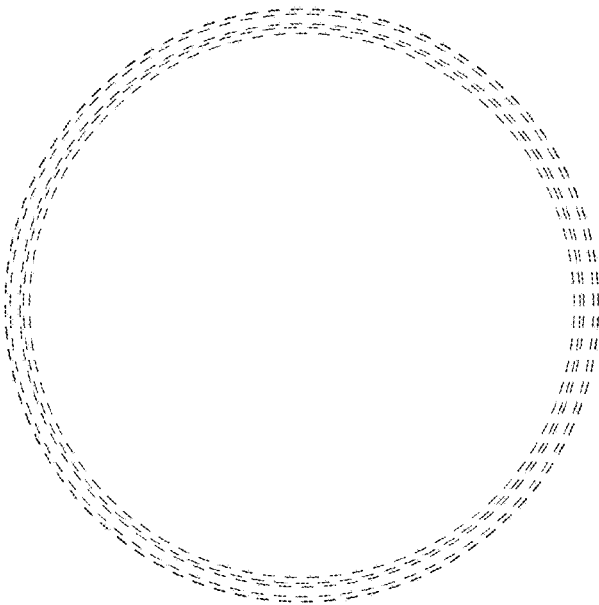

FIG. 7