



lb b

1

(態) (

가 가 가 가 가 가 2 가

가 가 가

가 가

54 - 16844

가 가 가

b b (同族)

lb b

lb b

10 ppm

(流水)

가

가

1

2

3

4

5

가

NO<sub>3</sub><sup>-</sup>

6

1

7 2 .  
 8 3 .  
 9 4 .

(1) 가  
 (4) (2) (4) (5) (6) (5) (6) (10)  
 (7) (7) (2)

(6) lb b , ,  
 (5) , , , , , ,

(5) (6) (5) 2  
 (9)가 (9) 가 (6) 가  
 (5) (9) (6) (5)  
 (9) (10) (5)

(2) (4)  
 (7) ON (6) (5) (6)  
 ( A).  
 ( B). A B

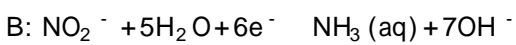
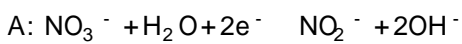

(5) (5) ( C). C

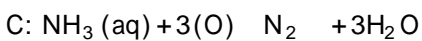

(2)

3 4 (6) 3  
 (6) 3  
 KNO<sub>3</sub> 가 300 Mℓ (5) (6) (5) NO<sub>3</sub><sup>-</sup> 10:1  
 0.001 M

3 , (6) lb b , , NO<sub>3</sub><sup>-</sup> , (6)

lb b NO<sub>3</sub><sup>-</sup> NO<sub>2</sub><sup>-</sup> . (6)

3 , 4 가 . 4 (advan ,

ce) , (6) , NO<sub>3</sub><sup>-</sup> (6) , ,

NO<sub>3</sub><sup>-</sup> NO<sub>2</sub><sup>-</sup> NO<sub>3</sub><sup>-</sup> NO<sub>2</sub><sup>-</sup> . ,

(6)

가 , NO<sub>3</sub><sup>-</sup> NO<sub>2</sub><sup>-</sup>

pH , ,

가 ,

(6) NO<sub>3</sub><sup>-</sup> , ,

(5) , (6)

가 (5) ( D) , (6)

D: NO<sub>2</sub><sup>-</sup> + H<sub>2</sub>O NO<sub>3</sub><sup>-</sup> + H<sup>+</sup> + 2e<sup>-</sup>

(5) , (6)

(6) (5) .

(5) , , (6) , ,

(5) (1) (5) (6) 가 ,

(5) (6) (9)가 , (5) (6) 가 (

6) , (6)

(5) (6) (9) , , (9)

(5) (6) , ,

, (5) 가 (9)

, (5) 가 (10) (6)

(5) (泳動) 가 .

, (9) NO<sub>3</sub><sup>-</sup> 가 (5) , (6) NO<sub>3</sub><sup>-</sup> 가 (9)

NO<sub>3</sub><sup>-</sup> (9)

, 가 NH<sub>4</sub><sup>+</sup> ,

, 5 가 NO<sub>3</sub><sup>-</sup> NO<sub>3</sub><sup>-</sup> 가 , NO<sub>3</sub><sup>-</sup> 가 .

가 (6) 가 (5)

. 가 ,

, 가 ,

, 10 ppm

, 가 , 가 가 가

4000 ppm 가 가 ,

, 가 , (5) (6)

가 (1)

, 1 , 6

BOD 가 (11) (11) COD BOD , COD

(1) (2)

, (11) COD BOD , 가 (1)

, (11) (11) (1)

, 2 7 ,

, 3  
(12)

8

가

(12)

(1)  
(13)

(1)  
(12)

(12)  
(12)  
(12)

가

(12)  
(1)

(12)

(1)

4

9

NOx 가

(1)

, NOx 가

가

lb

b

lb

b

10 ppm

가

COD BOD

COD BOD

(57)

1.

lb b (同族)

2.

가 lb b  
가

3.

가 lb b  
가

4.

3  
10 ppm

5.

1 4

6.



1 5 , ,  
가

7.

1 , ,

8.

1 7 , 가

9.

1 7

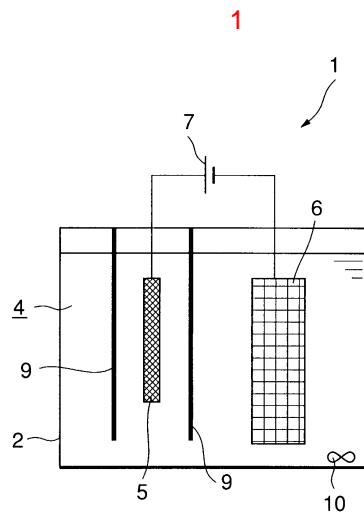

2

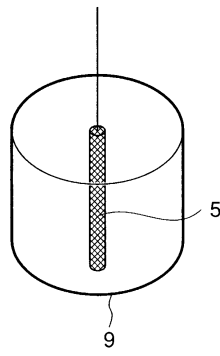

3

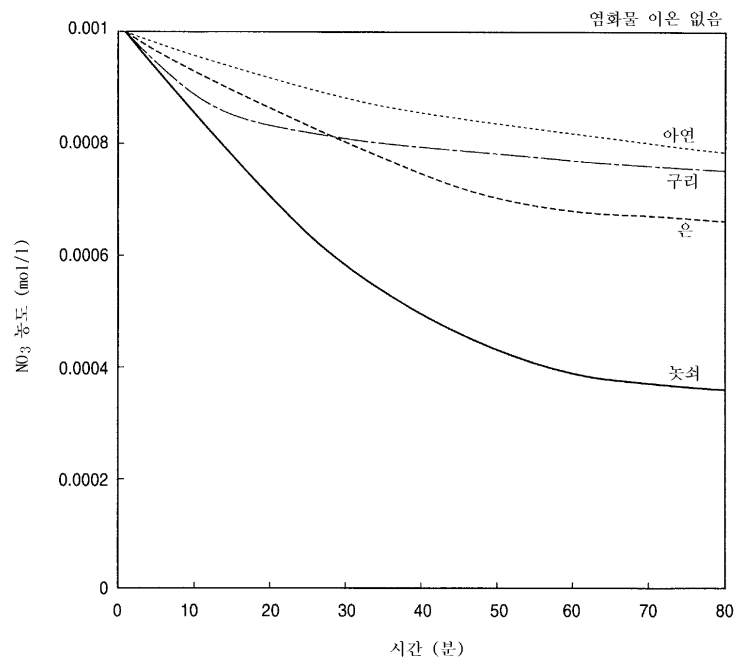

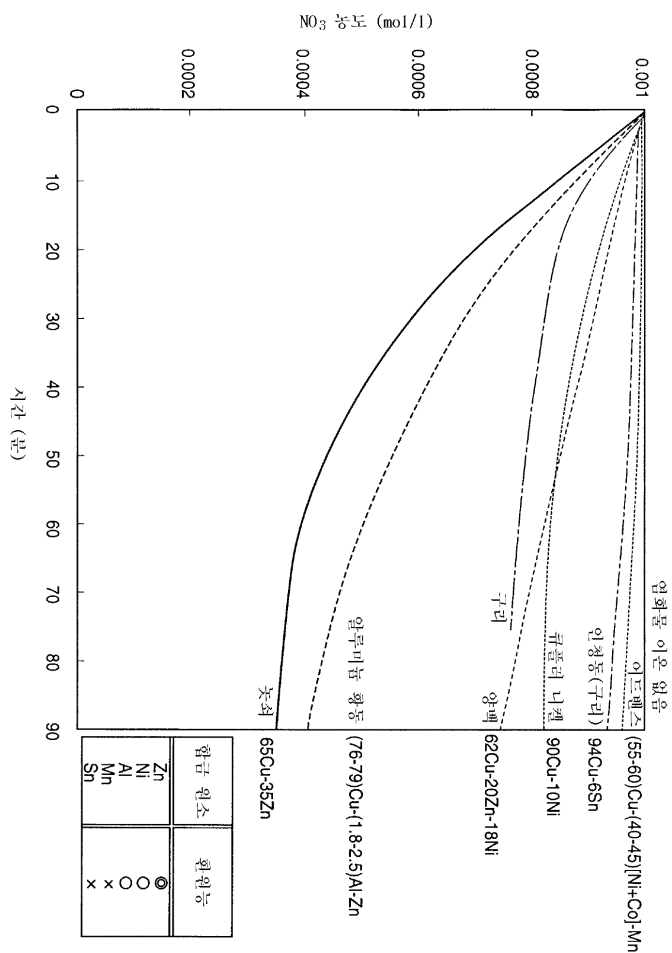

5

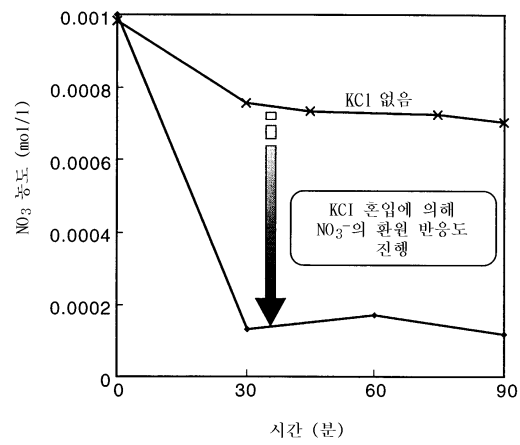

6

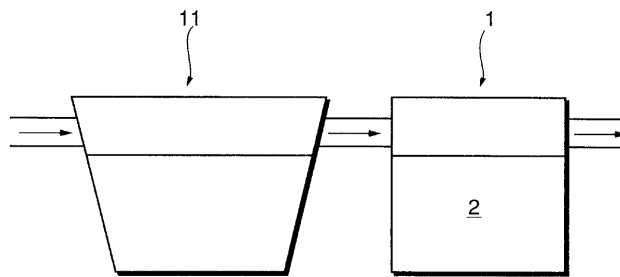

7

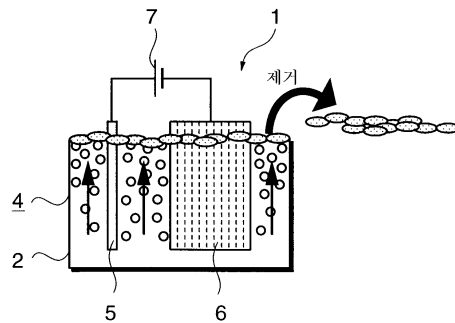

8

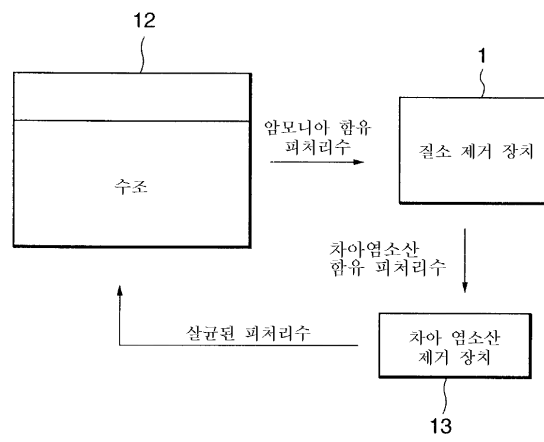

9

