

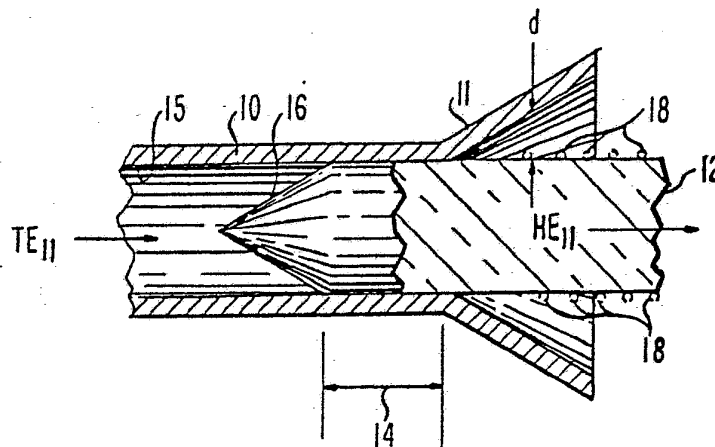

INTERNATIONAL APPLICATION PUBLISHED UNDER THE PATENT COOPERATION TREATY (PCT)

<p>(51) International Patent Classification³ : H01Q 13/02, 15/08</p>	<p>A1</p>	<p>(11) International Publication Number: WO 83/01711 (43) International Publication Date: 11 May 1983 (11.05.83)</p>
<p>(21) International Application Number: PCT/US82/01377 (22) International Filing Date: 30 September 1982 (30.09.82) (31) Priority Application Number: 315,670 (32) Priority Date: 28 October 1981 (28.10.81) (33) Priority Country: US (71) Applicant: WESTERN ELECTRIC COMPANY, INC. [US/US]; 222 Broadway, New York, NY 10038 (US). (72) Inventor: DRAGONE, Corrado ; 119 Pinckney Road, Little Silver, NJ 07739 (US). (74) Agents: HIRSCH, A., E., Jr. et al.; Post Office Box 901, Princeton, NJ 08540 (US).</p>		<p>(81) Designated States: DE (European patent), FR (European patent), JP. Published: <i>With international search report.</i> <i>With amended claims.</i></p>

(54) Title: WIDE BANDWIDTH HYBRID MODE FEEDS



(57) Abstract

Hybrid mode feeds which are capable of handling very wide bandwidths. In the present feed arrangements, a dominant TE_{11} mode is converted to the HE_{11} hybrid mode which is then launched. The TE_{11} to HE_{11} mode conversion is achieved by inserting a circular dielectric rod (12) into a flared end (11) of a smooth-walled cylindrical feedhorn until a small cylindrical section of the dielectric rod engages with the inner wall (15) of the unflared portion of the feedhorn. In one feed arrangement, the other end of the dielectric rod is similarly inserted into a flared end (21) of a corrugated cylindrical feedhorn section (22) until a short longitudinal section of the cylindrical portion of the rod is concentric with the corrugations of an unflared section of the feedhorn to provide a transition for the HE_{11} mode into the corrugated waveguide for subsequent launch. In a second feed arrangement, the dielectric rod at the aperture of the smooth-walled flared feedhorn is flared outward to end in a curved configuration which is shaped to minimize reflections back into the dielectric rod and provide a predetermined wavefront at the aperture of the feed.

FOR THE PURPOSES OF INFORMATION ONLY

Codes used to identify States party to the PCT on the front pages of pamphlets publishing international applications under the PCT.

AT	Austria	LI	Liechtenstein
AU	Australia	LK	Sri Lanka
BE	Belgium	LU	Luxembourg
BR	Brazil	MC	Monaco
CF	Central African Republic	MG	Madagascar
CG	Congo	MR	Mauritania
CH	Switzerland	MW	Malawi
CM	Cameroon	NL	Netherlands
DE	Germany, Federal Republic of	NO	Norway
DK	Denmark	RO	Romania
FI	Finland	SE	Sweden
FR	France	SN	Senegal
GA	Gabon	SU	Soviet Union
GB	United Kingdom	TD	Chad
HU	Hungary	TG	Togo
JP	Japan	US	United States of America
KP	Democratic People's Republic of Korea		

- 1 -

WIDE BANDWIDTH HYBRID MODE FEEDS

Background of the Invention1. Field of the Invention

5 The present invention relates to wide bandwidth hybrid mode feeds and, more particularly, to hybrid mode feeds which are capable of handling very wide bandwidths and include an arrangement which converts a dominant TE_{11} mode at the input to the feed into the HE_{11} hybrid mode, 10 which hybrid mode is then propagated further or launched into free space.

2. Description of the Prior Art

 An important consideration in designing antennas for terrestrial radio relay and satellite communication is 15 excellent radiation characteristics and very low return loss. In this regard the horn reflector is an excellent antenna, but its metal walls are generally uncorrugated. The horn antenna could be improved with corrugations but generally corrugated structures, especially in the size of 20 the horn reflector, are very difficult and expensive to produce. Additionally, the -40DB return loss over a very wide range of frequencies as found with the present uncorrugated horn reflectors is generally not obtainable with the present corrugated feeds.

25 U. S. Patent 4,040,061 issued to C. G. Roberts et al on August 2, 1977 describes a corrugated horn antenna allegedly having a useful operating bandwidth of at least 2.25:1. There, the antenna is fed with a waveguide in which a TM_{11} mode suppressor is disposed in a circular 30 waveguide section before the input wavefront encounters a flared corrugated horn. The mode suppressor functions to prevent the excitation of hybrid modes in the horn at the upper end of a wide band of frequencies which would cause an unacceptable deterioration in the radiation pattern.

35 U. S. Patent 4,021,814 issued to J. L. Kerr on May 3, 1977 relates to a broad-band corrugated horn antenna



- 2 -

with a double-ridged circular waveguide feed allegedly having a bandwidth handling capability greater than 2:1 without the introduction of lossy materials or resistive type mode suppressors. There, a plurality of ridges, each 5: having a predetermined width, and a plurality of gaps between the ridges, with each gap having a predetermined width, are provided wherein the width of the gaps is greater than the width' of the ridges.

It has been found that for a waveguide with 10 finite surface impedances, the fundamental HE_{11} mode approaches, under certain conditions the behavior that the field essentially vanishes at the boundary and the field is essentially polarized in one direction. Because of these properties, such a mode is useful for long distance 15 communication since it is little affected by wall imperfections or wall losses and provides an ideal illumination for a feed for reflector antennas. In general, it is difficult to excite the HE_{11} mode in a corrugated feed since, at the input, the feed is usually 20 excited by the TE_{11} mode of a circular waveguide with smooth metal walls. For the TE_{11} mode, the transverse wavenumber, σ , is related to the waveguide radius by $\sigma a = 1.84184$. At the feed aperture, however, for the desired HE_{11} mode, $\sigma a = 2.4048$. Thus the mode parameter $u = \sigma a$ must 25 increase from 1.84184 to about 2.404 as the mode propagates from the input of the feed to the aperture.

In a corrugated waveguide, u is known to be a decreasing function of the corrugations depth d . Therefore, in order for u to increase, d must decrease in 30 the direction of propagation. To satisfy this requirement, corrugated feeds are usually designed as shown in FIGS. 1 and 2a of U. S. Patent 3,618,106 issued to G. H. Bryant on November 2, 1971. In this regard, see also the articles "Reflection, Transmission and Mode Conversion in a 35 Corrugated Feed" by C. Dragone in BSTJ, Vol. 56, No. 6, July-August 1977 at pp. 835-867 and "Characteristics of a Broadband Microwave Corrugated Feed: A Comparison Between



- 3 -

Theory and Experiment" by C. Dragone in BSTJ, Vol. 56, No. 6, July-August 1977, at pp. 869-888. In such arrangement, the input discontinuity of d causes a reflection which vanishes at the frequency satisfying
5 $\lambda_r = 2d$, where λ_r is the wavelength in the radial lines of the input corrugations. The feed can thus be used effectively only in the vicinity of this frequency and, as a consequence, bandwidths in excess of 100 percent are difficult to obtain.

10 Other arrangements for transforming the TE_{11} mode into the HE_{11} mode, for subsequent launch from a feed, using helically wound wire structures bonded to the interior surface of a waveguide are disclosed in U. S. Patents 4,231,042 issued to R. H. Turrin on October 28,
15 1980 and 4,246,584 issued to A. R. Noerpel on January 20, 1981.

The problem remaining in the prior art is to provide wide bandwidth hybrid mode feeds which are simpler to fabricate than prior art type feeds with wide bandwidth
20 and also provide negligible reflection and generation of unwanted modes over bandwidths in excess of two octaves.

Summary of the Invention

The foregoing problem in the prior art has been solved in accordance with the present invention which
25 relates to wide bandwidth hybrid mode feeds and, more particularly, to hybrid mode feeds which are capable of handling very wide bandwidths and include an arrangement which converts a dominant TE_{11} mode at the input to the feed into the HE_{11} hybrid mode, which hybrid mode is then
30 propagated further or launched into free space.

It is an aspect of the present invention to provide hybrid mode feeds which are capable of handling very wide bandwidths wherein the dominant TE_{11} mode is converted to the HE_{11} mode which is then launched. The
35 TE_{11} to HE_{11} mode conversion is achieved by inserting a circular dielectric rod into a flared end of a smooth-walled cylindrical feedhorn until a small cylindrical



- 4 -

section of the dielectric rod engages the inner wall of the unflared portion of the feedhorn. In one feed arrangement, the other end of the dielectric rod is similarly inserted into a flared end of a corrugated cylindrical feedhorn section until a short longitudinal section of the cylindrical portion of the rod engages the corrugations of an unflared cylindrical section of the feedhorn to provide a transition for the HE_{11} mode into the corrugated waveguide for subsequent launch. In a second feed arrangement, the dielectric rod at the aperture of the smooth-walled flared feedhorn is spherically flared outward to end in a curved configuration which is preferably shaped to minimize reflections back into the dielectric rod.

Other and further aspects of the present invention will become apparent during the course of the following description and by reference to the accompanying drawings.

Brief Description of the Drawings

Referring now to the drawings, in which like numerals represent like parts in the several views:

FIG. 1 illustrates a cross-sectional view of the TE_{11} to HE_{11} mode conversion section in accordance with the present invention;

FIG. 2 illustrates a cross-sectional view of a feed arrangement in accordance with the present invention which includes the mode conversion section of FIG. 1;

FIG. 3 illustrates a cross-sectional view of an alternative feed arrangement in accordance with the present invention which includes the mode conversion section of FIG. 1; and

FIG. 4 illustrates a cross-sectional view of the feed arrangement of FIG. 3 which is modified to permit the absorption of reflected waves.

Detailed Description

FIG. 1 illustrates a mode conversion arrangement which transforms efficiently, over a wide range of frequencies, the TE_{11} mode into the HE_{11} mode. Such

- 5 -

transformation into the HE_{11} mode is desired in order to obtain from a circular feed the radiation characteristics where the field essentially vanishes at the boundary and the field is essentially polarized in one direction. The arrangement of FIG. 1 comprises a circular waveguide 10 which includes an outwardly-flared end section 11, and a rod 12 of dielectric material which has an end section thereof in radial engagement with a longitudinal section 14 of the inner surface 15 of waveguide 10, adjacent the flared end section 11, and extends longitudinally outward from the flared end section 11.

Dielectric rod 12 is shown as comprising a conical end 16 for providing a smooth transition interface for the TE_{11} mode entering dielectric rod 12 from waveguide 10. It is to be understood that such conical end 16 of dielectric rod 12 is preferred but optional and is for purposes of exposition and not for purposes of limitation since other shaped ends such as, for example, a flat end, which is not preferred due to reflections being directed directly backward, or a tapered end could be used to provide a proper transition boundary. Also shown is an optional helical wire structure 18 surrounding dielectric rod 12 in the area both within and beyond the flared end section 11 of waveguide 10, which can be used to improve the performance by containing any of the field found at the boundary.

In operation, the TE_{11} mode propagates from a source (not shown) down waveguide 10 and enters the conical end 16 of dielectric rod 12 and propagates therein until it reaches the beginning of flared end 11 of waveguide 10. It has been found that by placing a dielectric rod 12 inside an ordinary waveguide 10 comprising smooth metal walls, the mode parameter, u , is found to decrease as the distance d between the outer surface of dielectric rod 12 and the inside wall 15 of waveguide 10 is gradually increased. As a consequence, to obtain the HE_{11} mode, starting from the TE_{11} mode, it is sufficient to increase d in the direction

- 6 -

of propagation, starting from $d=0$ as shown in FIG. 1 to the end of flared section 11. Beyond the wide end of flared section 11, the distance d is so large that it can be assumed that the HE_{11} mode is guided entirely by dielectric rod 12. Therefore, the metal walls of waveguide 10 and its flared end 11 can be removed especially since, for the HE_{11} mode, the field essentially vanishes at the boundary of dielectric rod 12. The HE_{11} mode can then be propagated further down dielectric rod 12. Optional helical windings 18 merely aid in containing any of the HE_{11} mode at the boundary within rod 12 as stated hereinbefore.

Having obtained the HE_{11} mode in a dielectric rod 12 as shown in FIG. 1 and described hereinbefore, the ensuing description relates to arrangements which expand the arrangement of FIG. 1 to permit the launching of the HE_{11} mode into free space as found with an antenna feed. One such arrangement in accordance with the present invention is shown in FIG. 2. There, the HE_{11} mode propagating in dielectric rod 12 enters a corrugated waveguide structure 20 comprising a first flared end 21, a cylindrical section 22 and a second flared end 23. More particularly, the HE_{11} mode propagating in dielectric rod 12 enters the first flared end 21 of corrugated waveguide 20 where the distance, d , of the corrugated walls from the dielectric rod 12 is large to prevent reflection or excitation of unwanted modes. In first tapered end 21, the distance d is gradually decreased until the corrugated walls touch the outer periphery of dielectric rod 12. The HE_{11} mode will propagate in first tapered end 21 without conversion to other modes provided $Y \neq \infty$, where $Y = -j \frac{Z}{Z_1}$, Z is the wave impedance of the homogeneous medium filling the waveguide and Z_1 is the finite surface impedance in the longitudinal direction of the waveguide. By properly choosing the parameters of the corrugated waveguide, such condition can be satisfied over a very wide frequency range.



On reaching cylindrical corrugated waveguide section 22 the dielectric rod 12 can be terminated in cylindrical section 22 by any suitable configuration as, for example, the conical end 24 shown or other tapered configuration. It can be shown that such arrangement does not result in the generation of unwanted modes, assuming the transition is long enough. The HE_{11} mode then propagates down waveguide section 22 for any desirable distance and is launched into free space, if desired, by second flared end 23 as is well known in the art for providing a smooth transition between a circular waveguide and free space. It is to be understood that the helical wound wire structure 18 of FIG. 1 could be included in the arrangement of FIG. 2 between cylindrical waveguide 10 and the cylindrical corrugated waveguide section 22, which cylindrical waveguide sections should be of a diameter to support the desired frequency range of interest.

FIG. 3 illustrates an alternative arrangement for launching the HE_{11} hybrid mode into free space after conversion of the TE_{11} mode into the HE_{11} mode by the arrangement of FIG. 1. There, a horn 30 is formed from dielectric material at the end of rod 12 having an index of refraction, n , appreciably greater than unity. The arrangement of FIG. 3 has the disadvantage that at low frequencies in the GHz range such feed would be large and weighty, but at higher GHz frequencies, e.g., above 18 GHz, the feeds are relatively small and would be attractive because of the simplicity of fabrication.

In the arrangement of FIG. 3, the TE_{11} mode is converted into the HE_{11} mode using the transition of FIG. 1. The HE_{11} mode then enters the dielectric horn section 30 where a spherical wave having essentially the field distribution of the HE_{11} mode propagates inside horn 30 towards the aperture 32. Aperture 32 is shown as a curved boundary of dielectric horn 30. At the aperture 32, because of the discontinuity in the index of refraction, the spherical wave is in part refracted and in part



- 8 -

reflected. The reflected wave is undesirable for it causes, inter alia, radiation by the feed in a backward direction. To minimize this effect and also, for example, to obtain a planar wavefront Σ after refraction at the surface of discontinuity at aperture 32 of horn 30, a proper surface configuration must be provided at aperture 32.

To determine the surface configuration to produce a planar wavefront Σ at aperture 32, the wavefront Σ after refraction is next considered. Since in the arrangement of FIG. 3 the spherical wave incident on the surface of discontinuity at aperture 32 originates from the vertex F_0 of horn 30, the optical path from point F_0 via a point P on the surface of discontinuity to a point Q on wavefront Σ must be a constant. Under such condition it can be shown that an ellipsoid of revolution with one of its foci at vertex F_0 and the other focus, F_1 , disposed such that $|F_1V|(n+1) = |F_0V|(n-1)$, where N is the dielectric refractive index and V is the point at the intersection of the refractive surface 32 and the feedhorn longitudinal axis 34 will provide a refractive surface producing a planar wavefront at aperture 32 of horn 30 after refraction. The wave reflected by the ellipsoidal surface is a spherical wave which converges towards the other focus F_1 of the ellipsoid and has essentially the HE_{11} mode pattern. Alternatively, if a spherical wavefront is desired after refraction at aperture 32, instead of a planar wavefront, the surface configuration should be either a spherical configuration with its focus at F_0 , which is undesirable since all reflected waves are directed right back into waveguide 10, or more generally, a Cartesian oval configuration which approximately focuses the reflected wave towards a focus between point F_0 and point V at the aperture. By focusing the reflected waves at a point F_1 close to aperture 32, the waves will pass through focus F_1 and upon reaching the tapered surface of horn 30, will be partly reflected and partly refracted. The reflected

- 9 -

portion will impinge the opposite wall of the tapered section of horn 30 where it will again be partly reflected and partly refracted, and so on. The signal intensity being reflected back into waveguide 10 in this manner will be considerably less than that of a surface of discontinuity which reflects waves directly back to vertex F_0 .

To reduce the magnitude of the resulting reflection coefficient, the arrangement of FIG. 3 can be modified to provide the arrangement shown in FIG. 4 where the ellipsoid axis is offset with respect to the longitudinal axis 34 of horn 30 so that second focus F_1 is disposed at the tapered boundary of horn 30. In such arrangement, all spherical waves emanating from vertex F_0 are partially refracted and partially reflected at the offset ellipsoid 40 so that the reflected part is focused to focal point F_1 . Then, by the disposition of absorbing material 41 on the periphery of horn 30 in the vicinity of focal point F_1 , the reflected wave can be suppressed without greatly affecting the incident wave whose amplitude is small at the boundary. Because of the nonzero angle α between the axes of horn 32 and ellipsoid 40 there will be generated after refraction some cross-polarization components which are essentially the same as the cross-polarization components produced by a feed offset by the same angle α . For small angles of horn 32 taper, this cross-polarized component can be suppressed by combining the feed with a suitable arrangement of reflectors as, for example, disclosed in U. S. Patent 4,166,276 issued to C. Dragone on August 28, 1979.

In the arrangements of FIGS. 3 and 4, the dielectric rod 12 and dielectric horn 30 are shown encircled by an optional helically wound wire structure 18 to provide improved performance. Such helical wire structure is, however, only shown for purposes of exposition and not for purposes of limitation since experiments have shown excellent results without the use of a helical wire

- 10 -

structure 18.

It is to be understood that in the arrangement of FIG. 2, dielectric rod 12 may not be manufactured to precisely match the inner diameter of smooth walled waveguide 10 and corrugated waveguide section 22. Therefore, in actual construction, a frame (not shown) can fixedly support both waveguides in position rather than depending on a tight fit of dielectric rod 12. In addition, dielectric rod 12 need not correspond to the inner diameter of the corrugated waveguide section 22 which can be slightly greater than the outer diameter of dielectric rod 12, and in such arrangement dielectric rod 12 can then be supported to the corrugations by dielectric washers or spacers (not shown) or held in position by the frame. In such latter arrangement, the HE_{11} mode will still be transferred to corrugated waveguide section 22 provided the tapered end of dielectric rod 12 is sufficiently long.



Claims

1. A hybrid mode feed arrangement comprising mode conversion means (10, 11, 12) for converting a dominant TE_{11} mode into a HE_{11} hybrid mode,
5 CHARACTERIZED IN THAT
the mode conversion means comprises
a smooth-walled feedhorn comprising a hollow
conductive cylindrical waveguide section (10) for
propagating the TE_{11} mode introduced at the entrance of the
10 mode conversion means and a flared conductive end
section (11) at the aperture of the mode conversion means,
the hollow waveguide and flared end sections including an
inner (15) and an outer longitudinal wall surface; and
a cylindrical rod (12) of dielectric material
15 comprising an end section including an outer wall which
symmetrically engages a longitudinal portion (14) of the
inner surface of the hollow waveguide section for
intercepting the TE_{11} mode propagating in said hollow
waveguide section, said end section of the rod extending
20 through the flared end section and beyond the aperture of
the feedhorn in a non-contacting arrangement for converting
the TE_{11} mode into the HE_{11} mode and propagating the HE_{11}
mode therein.

2. A hybrid mode feed arrangement according to
25 claim 1,
CHARACTERIZED IN THAT
the feed arrangement further comprises:
guiding means (20, 30) disposed at the output of
the mode conversion means for continuing the propagation of
30 the HE_{11} mode produced by said mode conversion means.

3. A hybrid mode feed arrangement according to
claim 2

CHARACTERIZED IN THAT
the guiding means comprises a corrugated
35 feedhorn (20) comprising:
a hollow conductive cylindrical waveguide
section (22) including a corrugated inner surface which is

- 12 -

concentric, over a longitudinal subsection on one end thereof, with the outer wall of a second end section of the cylindrical rod which protrudes from the aperture of the mode conversion means for intercepting the HE_{11} mode propagating in the cylindrical rod; and

5 a conductive flared end section (21) extending from said one end of said hollow conductive corrugated waveguide section and disposed in a non-contacting arrangement with the cylindrical rod between the aperture
10 of the mode conversion means and the corrugated waveguide section of said guiding means for providing a smooth transfer of the HE_{11} mode propagating in the cylindrical rod to said corrugated waveguide section.

4. A hybrid mode feed arrangement according to
15 claim 3

CHARACTERIZED IN THAT

the guiding means further comprises:

a second conductive flared end section (23) extending from a second end of said hollow conductive
20 corrugated waveguide section for launching the HE_{11} mode propagating in the corrugated waveguide section of said guiding means.

5. A hybrid mode feed arrangement according to
claim 2

25 CHARACTERIZED IN THAT

the guiding means comprises an outwardly tapered conical horn (30) of dielectric material formed at an end of the cylindrical rod which extends beyond the aperture of said feedhorn, the conical horn including a Cartesian oval
30 configuration at the wide end thereof forming an aperture of the conical horn.

6. A hybrid mode feed arrangement according to
claim 2

CHARACTERIZED IN THAT

35 the guiding means comprises an outwardly tapered conical horn (30) of dielectric material formed at an end of the cylindrical rod which extends beyond the aperture of



- 13 -

said feedhorn, the conical horn including a spherical configuration at the wide end thereof forming an aperture of the conical horn.

5 7. A hybrid mode feed arrangement according to claim 2

CHARACTERIZED IN THAT

10 the guiding means comprises an outwardly tapered conical horn (30) of dielectric material formed at an end of the cylindrical rod which extends beyond the aperture of said feedhorn, the conical horn including an elliptical configuration at the wide end thereof forming an aperture of the conical horn.

15 8. A hybrid mode feed arrangement according to claim 2

CHARACTERIZED IN THAT

20 the guiding means comprises an outwardly tapered conical horn (30) of dielectric material formed at an end of the cylindrical rod which extends beyond the aperture of said feedhorn, the conical horn including an offset elliptical configuration at the wide end thereof forming an aperture of the horn.

25 9. A hybrid mode feed arrangement according to claim 8

CHARACTERIZED IN THAT

30 the offset elliptical configuration at the wide end of said conical horn is arranged with a first focal point thereof corresponding with a vertex point of said conical horn and a second focal point thereof being disposed on the tapered boundary of said conical horn; and

35 the guiding means further comprises material capable of absorbing electromagnetic energy impinging thereon which absorbing material is disposed on the tapered boundary of the conical horn at said second focal point of said elliptical configuration.

 10. A hybrid mode feed arrangement according to claim 1 or 2



- 14 -

CHARACTERIZED IN THAT

the feed arrangement further comprises:

a helically wound wire structure (18) disposed
around the cylindrical rod in the area of the end section
5 of said rod which extends through the flared conductive end
section of the feedhorn and beyond the aperture thereof.

AMENDED CLAIM

[received by the International Bureau on 14 March 1983 (14.03.83);
original claim 1 has been amended; the amended text of claim 1 follows]

1. (AMENDED) A hybrid mode feed arrangement comprising mode conversion means (10,11,12) for converting a dominant TE_{11} mode into a HE_{11} hybrid mode having a feedhorn comprising a hollow conductive waveguide section for propagating the TE_{11} mode introduced at the entrance of the mode conversion means and a flared conductive end section at the aperture of the mode conversion means, the hollow waveguide and flared end sections including an inner and an outer longitudinal wall surface, and
- a cylindrical rod of dielectric material,
CHARACTERIZED BY
- the hollow conductive waveguide section (10) being cylindrical and smooth-walled, the rod (12) comprising an end section including an outer wall which symmetrically engages a longitudinal portion (14) of the inner surface of the hollow waveguide section for intercepting the TE_{11} mode propagating in the hollow waveguide section, and the end section of the rod extending through the flared end section (11) and beyond the aperture of the feedhorn in a non-contracting arrangement for converting the TE_{11} mode into the HE_{11} mode and propagating the HE_{11} mode beyond the aperture.



FIG. 1

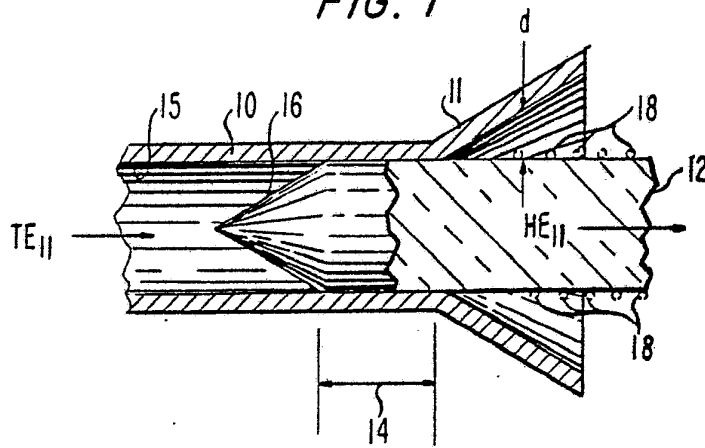

FIG. 2

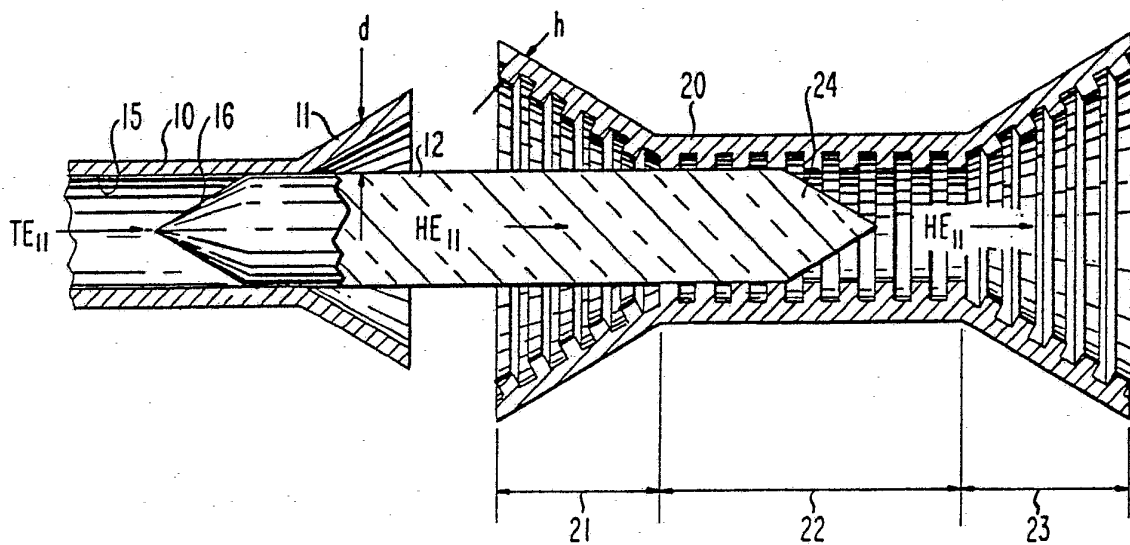

FIG. 3

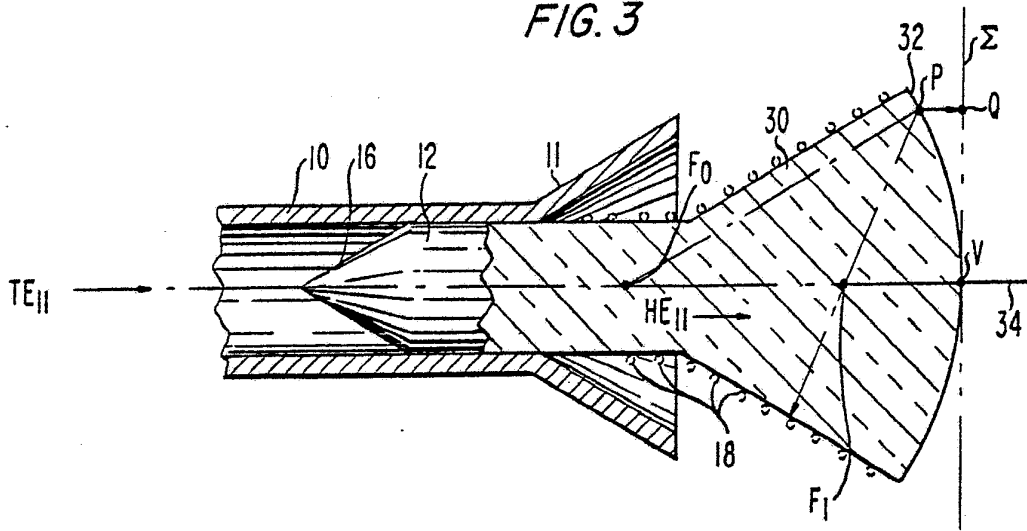
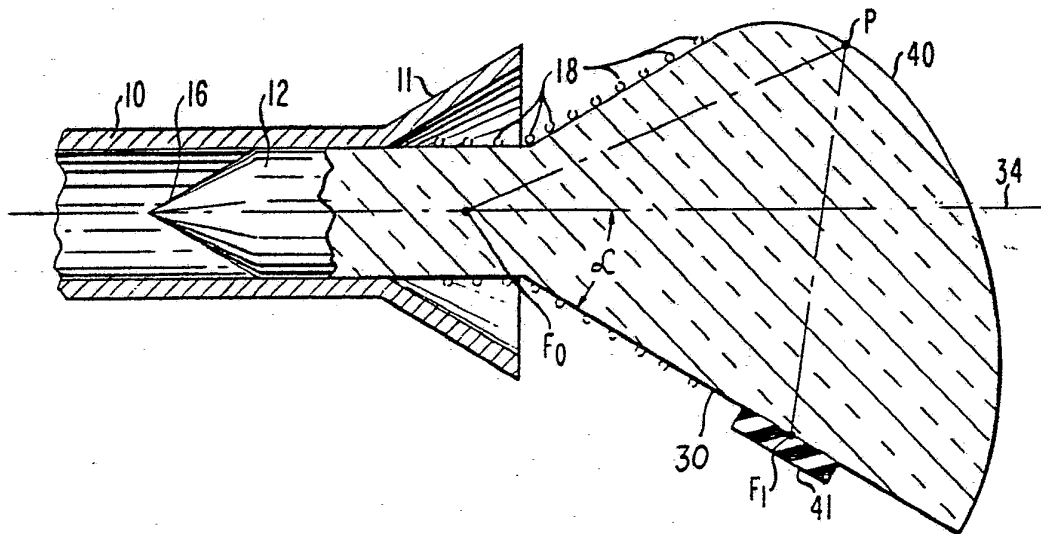
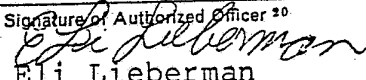

FIG. 4



INTERNATIONAL SEARCH REPORT

International Application No PCT/US82/01377

I. CLASSIFICATION OF SUBJECT MATTER (if several classification symbols apply, indicate all) ³		
According to International Patent Classification (IPC) or to both National Classification and IPC		
INT. CL. ³ H01Q 13/02; H01Q 15/08		
U.S. CL. 343/786,754		
II. FIELDS SEARCHED		
Minimum Documentation Searched ⁴		
Classification System	Classification Symbols	
U.S.	343/754,783,785,786	
Documentation Searched other than Minimum Documentation to the Extent that such Documents are Included in the Fields Searched ⁵		
III. DOCUMENTS CONSIDERED TO BE RELEVANT ¹⁴		
Category [*]	Citation of Document, ¹⁶ with indication, where appropriate, of the relevant passages ¹⁷	Relevant to Claim No. ¹⁸
Y	U.S., A, 3,605,101 Published 14 September 1971, (Kolettis et al)	1, 2
A	U.S., A, 3,055,004 Published 18 September 1962,	1-10
<p>[*] Special categories of cited documents: ¹⁵</p> <p>"A" document defining the general state of the art which is not considered to be of particular relevance</p> <p>"E" earlier document but published on or after the international filing date</p> <p>"L" document which may throw doubts on priority claim(s) or which is cited to establish the publication date of another citation or other special reason (as specified)</p> <p>"O" document referring to an oral disclosure, use, exhibition or other means</p> <p>"P" document published prior to the international filing date but later than the priority date claimed</p> <p>"T" later document published after the international filing date or priority date and not in conflict with the application but cited to understand the principle or theory underlying the invention</p> <p>"X" document of particular relevance; the claimed invention cannot be considered novel or cannot be considered to involve an inventive step</p> <p>"Y" document of particular relevance; the claimed invention cannot be considered to involve an inventive step when the document is combined with one or more other such documents, such combination being obvious to a person skilled in the art.</p> <p>"Z" document member of the same patent family</p>		
IV. CERTIFICATION		
Date of the Actual Completion of the International Search ²	Date of Mailing of this International Search Report ²	
20 JANUARY 1983	26 JAN 1983	
International Searching Authority ¹	Signature of Authorized Officer ²⁰	
ISA/US	 Eli Lieberman	