

(19) World Intellectual Property Organization
International Bureau



(43) International Publication Date
26 July 2001 (26.07.2001)

PCT

(10) International Publication Number
WO 01/53059 A1

- (51) International Patent Classification⁷: **B29C 47/06**, C04B 35/80
- (74) Agent: **CHERSKOV, Michael, J.**; Cherskov & Flaynik, The Civic Opera Building, 20 North Wacker Drive, Chicago, IL 60606 (US).
- (21) International Application Number: PCT/US01/02140
- (22) International Filing Date: 22 January 2001 (22.01.2001)
- (25) Filing Language: English
- (26) Publication Language: English
- (30) Priority Data:
09/489,983 21 January 2000 (21.01.2000) US
- (71) Applicant (for all designated States except US): **THE UNIVERSITY OF CHICAGO** [US/US]; 5801 S. Ellis Avenue, Chicago, IL 60637 (US).
- (72) Inventors; and
- (75) Inventors/Applicants (for US only): **GORETTA, Kenneth, C.** [US/US]; 430 Buckingham Pl., Downers Grove, IL 60516 (US). **SINGH, Dileep** [US/US]; 2215 Periwinkle Lane, Naperville, IL 60526 (US). **POLZIN, Bryant, J.** [US/US]; 1091 Candlewood Drive, Downers Grove, IL 60515 (US). **CRUSE, Terry** [US/US]; 2755 Windsor Drive, Lisle, IL 60532 (US). **PICCIOLO, John, J.** [US/US]; 1122 Lincoln Street, Lockport, IL 60441 (US).
- (81) Designated States (national): AE, AL, AM, AT, AU, AZ, BA, BB, BG, BR, BY, CA, CH, CN, CU, CZ, DE, DK, EE, ES, FI, GB, GD, GE, GH, GM, HR, HU, ID, IL, IN, IS, JP, KE, KG, KP, KR, KZ, LC, LK, LR, LS, LT, LU, LV, MD, MG, MK, MN, MW, MX, NO, NZ, PL, PT, RO, RU, SD, SE, SG, SI, SK, SL, TJ, TM, TR, TT, UA, UG, US, UZ, VN, YU, ZA, ZW.
- (84) Designated States (regional): ARIPO patent (GH, GM, KE, LS, MW, MZ, SD, SL, SZ, TZ, UG, ZW), Eurasian patent (AM, AZ, BY, KG, KZ, MD, RU, TJ, TM), European patent (AT, BE, CH, CY, DE, DK, ES, FI, FR, GB, GR, IE, IT, LU, MC, NL, PT, SE, TR), OAPI patent (BF, BJ, CF, CG, CI, CM, GA, GN, GW, ML, MR, NE, SN, TD, TG).
- Published:
— with international search report
- For two-letter codes and other abbreviations, refer to the "Guidance Notes on Codes and Abbreviations" appearing at the beginning of each regular issue of the PCT Gazette.

(54) Title: METHOD FOR FABRICATING CERAMIC COMPOSITES, FIBROUS CERAMIC MONOLITHS

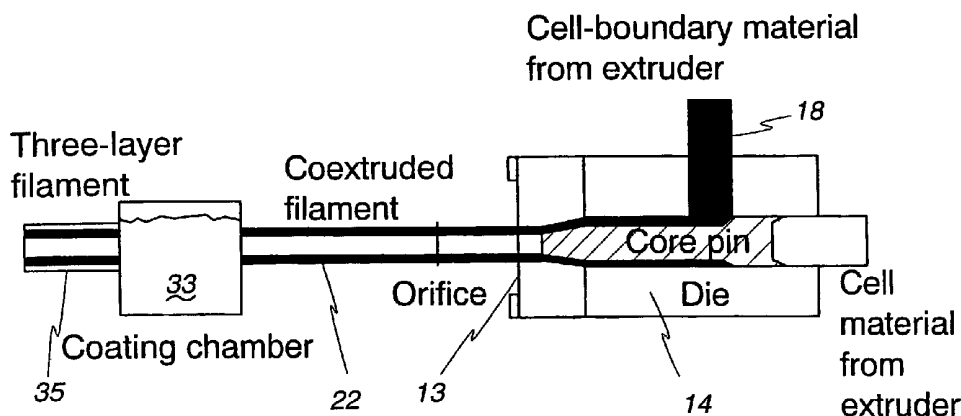

(57) Abstract: A method for producing composite ceramic material (22) is provided wherein a core ceramic structure (21) is produced and simultaneously enveloped with a sleeve (23) of similar material.



WO 01/53059 A1

METHOD FOR FABRICATING CERAMIC COMPOSITES,
FIBROUS CERAMIC MONOLITHS

CONTRACTUAL ORIGIN OF THE INVENTION

The United States Government has rights in this invention under Contract No. W-31-109-ENG-38 between the U.S. Department of Energy and the University of Chicago representing Argonne National Laboratory.

5

BACKGROUND OF THE INVENTION

1. Field of the Invention.

The present invention relates to a method for fabricating composite ceramic structures, and more particularly, the present invention relates to a method for fabricating multi-phase ceramic filaments to be used as building blocks for the structures.

10

2. Background of the Invention

When monolithic ceramic structures are stressed to the point of failure, they often fail with little or no warning, i.e., catastrophically. These monolithic ceramics simply load elastically to a maximum stress and then fail all at once.

15

Several techniques for improving the toughness of ceramic structures have been attempted. For example, fibers have been added to bulk ceramic material to increase its toughness. These are called continuous fiber ceramic composites.

However, even these tougher materials can fail catastrophically.

Attempts have been made at forming ceramic structures which fail "gracefully" (i.e., with warning). One of these structures are known as fibrous monoliths (FMs), and are fabricated from billets comprising a composite ceramic containing both a strong cellular phase (a core) surrounded by a phase (in the form of a sleeve) designed to dissipate energy during fracture. Current FM production processes utilize multi-step protocols and heterogeneous materials. These processes make use of ram extrusion of slugs, and are thus batch processes by definition.

U.S. Patent No. 4,772,524 awarded to Coblenz on September 20, 1988 discloses a fibrous monolith whereby a cotton thread runs co-axially with the monolith produced. U.S. Patent No. 5,645,781 awarded to Popovic et al. on July 8, 1997 discloses a method for clamping or wrapping a sleeve of ceramic material around a dense core of ceramic material. These processes require separate steps and are thus considered "batch" operations.

Another drawback to current FM production processes is that hot pressing (often in an inert atmosphere) is generally used to densify the materials after their formation. To date, hot pressing in an inert atmosphere has been used to densify FMs such as silicon nitride (cell)/boron nitride (cell boundary) systems and diamond-cobalt (cell)/cobalt (cell boundary) systems. These FMs have been made from thermoplastic co-polymer blends that also require special processing during extrusion, such as close control of pressure and need for use of elevated temperatures above 160 °C. Hot pressing limits the shapes of the FMs that can be produced. Also, this process is costly.

A need exists in the art for a process for producing ceramic composites which utilize common extrusion equipment and similar phase materials. The process should produce a structure which yields gracefully. The process also should utilize common ceramic materials and sintering steps conducted in air and at ambient pressure to further minimize cost. Finally, the process should incorporate the least number of steps, and preferably comprise a single step or continuous process so as to expedite production in large industrial scale scenarios.

SUMMARY OF THE INVENTION

It is an object of the present invention to provide a method for producing ceramic composite materials that overcomes many of the disadvantages of the prior art.

Another object of the present invention is to provide a continuous process
5 for producing ceramic composite material. A feature of the invented method is the use of a standard extrusion machine. An advantage of the invented method is that minimal fabricator training is required, resulting in an optimization of personnel and existing equipment, and ultimately lower costs.

Yet another object of the present invention is to provide a process for
10 producing robust unidirectional or multidirectional fibrous monoliths. A feature of the invented method is careful matching of shrinkages and thermal-expansion coefficients of the various phases comprising the monoliths. An advantage of the invented method is the ability to sinter in air and at atmospheric pressure (i.e., pressure-less sintered) to produce the fibrous monoliths, thereby obviating the
15 need for hot pressing in an inert atmosphere to accomplish densification. This leads to a reduction in cost of many FM parts by a factor of up to 100.

Still another object of the present invention is to provide a process for producing fibrous monoliths which are stable at a myriad of operating conditions. A feature of the process is the utilization of different particles sizes of the same
20 compound for both the cell phase and the cell boundary layer. An advantage of the invented process is the elimination of material compatibility problems, thereby also eliminating diffusion between phases so as to permit operation at higher temperatures. Stability in oxidizing, inert and reducing temperatures also is realized.

Yet another object of the present invention is to provide layered materials
25 comprised of multi-phased filaments. A feature of the invention is that when the filaments are juxtaposed or "laid up" next to each other prior to pressing, no voids exist between the filaments. An advantage of the invention is that eventual packing of these composite strands results in very dense structures, sans any
30 voids or deformations between the filamentous components, so as to render the materials with high strength and toughness.

Briefly, the invention provides for a method for producing composite ceramics, the method comprising simultaneously forming a ceramic core coaxial with a ceramic sleeve.

Also provided is a fibrous monolith comprising a plurality of multi-phase
5 filaments
arranged in a configuration to cause graceful failure of the monolith when the monolith is placed under mechanical stress.

A fibrous monolith comprising a plurality of two-phase filaments containing $ZrSiO_4$ is also provided.

10

BRIEF DESCRIPTION OF THE DRAWINGS

These and other objects and advantages of the present invention will become readily apparent upon consideration of the following detailed description and attached drawing, wherein:

FIG. 1A is a schematic depiction of the invented co-extrusion process, in
15 accordance with features of the present invention;

FIG. 1B is a view of FIG 1A taken along line B-B;

FIG. 1C is a schematic depiction of a continuous hopper configuration, in accordance with features of the present invention;

FIG. 1D is a schematic diagram of the invented co-extrusion process and
20 coating process, in accordance with features of the present invention;

FIG. 2 is a schematic depiction of a process for producing unidirectional fibrous monoliths from the invented duplex filaments, in accordance with features of the present invention;

FIG. 3 is a stress v. displacement curve for typical monolithic ceramics;

25 FIG. 4 is a stress v. displacement curve for a fibrous monolith produced from duplex filaments produced via the invented method, in accordance with features of the present invention;

FIG. 5 is a thermal expansion curve for the $ZrSiO_4$ constituents in a duplex filament, in accordance with features of the present invention;

30 FIG. 6 is a photomicrograph depicting stress faults through the invented construct, in accordance with features of the present invention;

FIG. 7 is a schematic depiction of deformation occurring in packing ovoid-shaped or round fibrous monoliths;

FIG. 8 is a perspective view of laid-up non-ovoid filaments, in accordance with features of the present invention;

FIG. 9 is a cross section of a two phase filament with round-corner cell phase, in accordance with features of the present invention; and

5 FIG. 10 is a perspective of a graded fibrous monolith structure, in accordance with features of the present invention.

DETAILED DESCRIPTION OF THE INVENTION

A low-cost, highly optimized method for producing fibrous monoliths from duplex ceramic filaments is provided. Salient features of the invented method
10 include the simultaneous formation and envelopment of a ceramic core phase with a ceramic sleeve phase. This simultaneous formation is the result of the continuous extrusion of FM filaments, including solid freeform fabrication, so as to achieve net-shape fabrication of FMs.

Generally, the core phase is relatively dense compared to the sleeve
15 phase, the latter commonly referred to as the cell boundary phase.

The resulting duplex filaments represent a composite structure containing a strong continuous cellular phase surrounded by a second phase that is designed to dissipate energy during failure. This second or surrounding boundary phase has a non-brittle fracture characteristic to allow for gradual splitting and
20 delamination.

Specifically, metal oxide-based fibrous monoliths (FMs) containing porous cell boundaries and dense cells were fabricated by their simultaneous extrusion and subsequent lay up of filaments. The resulting construct was then sintered. Resulting bars of the material exhibited significant energy dissipation during
25 fracture and retained some load to large displacements. The FM bars exhibited clear evidence of crack deflection and delamination.

FIGS. 1 and 2 provide a schematic depiction of the process. The co-extrusion process, which produces the duplex filaments, is depicted as numeral
10 in FIG. 1. Cell material 12 from a screw extruder (not shown) enters the die 14 along the latter's longitudinal axis β . The cell material enters the die through a first
30 injection port 16.

The screw extruder allows cell material to be continuously fed into the first

injection port 16. As such, plug size is no longer a limiting factor. The invented continuous hopper design makes it possible to produce any length cell material desired. This configuration also streamlines FM fabrication procedures. For example, spoolable filaments can be produced.

5 Although screw extrusion is the preferred approach to producing continuous multilayer filaments, ram extrusion also can be used.

 A preferred method for continually feeding cell and/or boundary phase material into the filament die 14 is depicted in FIG. 1C. Generally, a screw-driven machine, designated as numeral 11 is utilized, material is fed into an open bore
10 15, from a continuous feed hopper 17. An axial rotating screw 19 forces the introduced material through an exit orifice 31.

 This continuous method allows for the substitution of cell and/or boundary materials in "mid-stream", inasmuch as individual hoppers can be utilized for different materials or for continuous production of multilayer filaments. In a ram
15 extruder, multiple slugs can be utilized without worrying about the joint or interface between plugs. This multiple hopper configuration thus facilitates the production of a cell- and/or boundary-phase comprised of a single constituent phase or of different materials along its linear axis, creating a linear variability of phase
20 constituency. This linear variability imparts different strengths and durabilities of the phase(s) along its (their) length(s).

 Alternatively, multiple hoppers facilitates the production of filaments of any length, inasmuch as the hoppers can be fed continuously.

 The filament 31 emanating from the hopper/screw configuration is then utilized either as a feed for cell phase material (at the first ingress point of the
25 extruder, element 16 FIG. 1A), or as a feed for the boundary phase material at the second ingress point (element 18 of FIG. 1A).

 Simultaneous with the injection of the cell material, cell boundary material 18 from a second screw extruder (also not shown) enters the die 14 from a second injection port 20. A duplex filament 22 is produced having a cell or core
30 21 and a boundary phase 23. This aspect of the production process can be performed at room temperature, inasmuch as the plastic materials representing

the injectable core and sleeve matter contain no thermoplastic materials that require heating to soften into a "workable" state. As such, the instant plastic materials are workable at room temperature.

These filaments 22 can be stored for up to several days.

5 Filament Manipulation
Detail

Once the filaments are formed, they can be pretreated in a myriad of ways, prior to being formed into bundles. For example, filaments 22 emanating from the die 14 can be coated with a material to impart a three- or four- or more-
10 layered structure to the filament. Coatings also can be employed to impart a desired texture to the outer surface of the resulting multi-phase filaments so as to increase friction and therefore stymie pull-out tendencies. Coatings also can be applied to impart additional ceramic layers, thereby fortifying the final strength characteristics of the resulting multi-phase filament.

15 An exemplary process for applying coating is illustrated in FIG. 1D. Briefly, duplex or multilayer filament 22 extruded from the die 14 is routed to a means for contacting the filament with a desired coating. For example, a coating chamber 33 is utilized after filament formation to apply a third phase 35 to the outside surface of the filament 22. Other coating means include dip coating, spray
20 coating, painting, or doctor-blade wiping.

The constituency of the coating will vary, depending on the characteristic desired by the coating. In the case of laying down an additional ceramic phase, approximate coating constituent values are as follows, plus or minus 30 percent of each value:

25 25 weight percent ceramic powder;
 58 weight percent solvent;
 14 weight percent binder;
 2 weight percent plasticizer; and
 1 weight percent dispersant.

30 The solvents, binders, plasticizers and dispersants utilized are standard for the ceramic process industry. Suitable constituents include xylene and/or butanol

for solvents, thermosetting acrylic polymers for binders, butyl benzyl phthalates for plasticizers and fish oil for dispersant. Exemplary constituents include 78/22 weight percent xylene/butanol as solvent, Rohm & Haas AT-51 binder, Monsanto S-160 plasticizer and Menhaden fish oil or similar standard dispersant.

5 Filament Arrangement
Detail

Ultimately, the filaments are formed into bundles 24. As depicted in FIG. 2, the filament bundle 24 is placed in an extrusion dye 26 and extruded to form unidirectional fibrous filaments 28. A punch 30 or similar device is utilized to force
10 the bundle through the exit orifice 32 of the extrusion dye. The masses for coextrusion (both core and sleeve) produce initial torque values of 4-12 newton meters. The coextrusion process requires a force of 5 to 50 MPa, most commonly 10-40 MPa. The ram extrusion process requires a force of 10-50 MPa, most commonly about 15-28 MPa.

15 The resulting FM filaments are then subjected to a lay up processes. In one lay up scenario, FM filament is first formed into sheets by, for example, sectioning the filament into lengths and arranging them side by side in a plate or bar die. Instead of side-by-side juxtaposition, the filaments can be serpentine along the plane in a die defining the sheet, or even patterned into a sheet in a
20 solid free form fabrication. The lay up process is completed by stacking and shaping the sheets to form FM test specimens.

The inventors have devised a graded structure, depicted in FIG. 10 as numeral 40, as a fibrous monolith configuration. In a preferred graded embodiment, peripheral regions 42 of the monolith 40 contain filaments
25 comprised of 60-90 volume percent cell phase. By contrast, the region of the monolith extending inwardly 44 (i.e., medially directed away from the periphery, contains filaments with at least approximately 5 volume percent lower cell phase, compared to its boundary phase. Generally, lower cell phase volume percents in the inner regions impart higher toughness to the body of the structure and higher
30 cell phase volume percents impart higher strength to the periphery region of the structure, which is typically subjected to higher stress.

An exemplary volume percent ratio in such a graded structure is 80/20

cell/boundary phase volume percent for periphery filaments and ≤ 75 percent cell phase/ ≥ 25 percent boundary phase for filaments residing in the inner portion of the monolith.

5 After laying up (which can be done by hand or with use of an automated system) and pressing the filaments into desired monolith configurations, the resulting structures are then sintered at temperatures ranging from approximately 1000 °C to 1600 °C for a time sufficient to achieve the desired density of the core phase and the porosity of the surrounding sleeve. Alternatively, instead of being subjected to sintering, the resulting structures are hot-pressed at
10 approximately the same temperatures.

Four point flexural tests were conducted on the cell material, cell-boundary material and FMs. FIG. 3 depicts the stress-displacement curves for the core material (solid line) and sleeve material (dotted line) before their combination to form a duplex filament. FIG. 4 depicts the stress-displacement curve for the FM
15 which represents a combination of the core and sleeve material. Both the core material and the sleeve material, when tested separately, exhibited fast fracture at maximum stresses of approximately 220 MPa and 430 MPa, respectively.

FIG. 4 shows FM bars failing at higher strain (compared to the materials depicted in FIG 3), as evidenced by the large area under its curve after the
20 maximum load has been attained, and also as depicted by the jagged, downward curve between 0.1mm displacement and 0.13 mm displacement. FIG. 4 shows three key features that provide the toughness characteristic of the FM material. The first feature is non-linearity prior to reaching maximum load. This feature is depicted in region A of FIG. 4 which shows a slight downward deviation of the
25 curve or a slight weakening of the construct between 0.08 mm and 0.105 mm displacement. The bending illustrated in region "A" depicts the small scale fracturing, which is indicated by acoustical or thermal signature. Such signatures serve as a warning that the component stress should be decreased to avoid failure.

30 The second feature, designated as "B", is a series of unload/loading steps during crack propagation. This second feature represents an intermediate zone

of fracturing of the construct, with splintering of the construct occurring more rapidly than that seen in the first phase (i.e. region "A") of failure.

The third feature of the invented FM is its retention of small load-carrying capability to very large strains. As depicted in region C of FIG. 4, some adherence remains in the construct, even after a precipitous drop in strength, so that approximately 5 to 7.5 MPa of yield is evident.

Scanning electron microscopy indicated that the unloading steps observed in the FM stress v. displacement curves were caused by energy-dissipating events such as crack delamination, crack deflection, and some cell pull-out. As depicted in FIG. 6, the inventors have found that primary cracks follow tortuous paths through the FM, making several 90 degree deviations through the cell-boundary phase 23 before continuing through the FM. Point 25 in FIG. 6 represents the fracture origin.

Cell and Boundary Configuration Detail

Strength of the resulting FMs is further enhanced if the individual filaments are configured to shapes to facilitate dense packing of the filaments. As such, in some instances, round filaments are to be eschewed to prevent the formation of void space or interstitial spaces (see "I" in FIG. 7) between laid up filaments. When these filaments are subsequently compressed to make monoliths, particularly when cross-ply laminates are made, a certain degree of collapsing or caving-in occurs to fill those interstitial spaces, thus forming cusps 40. This leads to distortion. Such distortion presents potential points of breakage, particularly when the angle between adjacent filament layers is 90 degrees.

To avoid the creation of spaces, rectangular or polygonal filaments instead are produced and juxtaposed to each other, as seen in FIG. 8. As such, resulting cross-ply laminates contain fewer and much smaller distortions. Compared to the laminate depicted in FIG. 7, the amount of energy required to pull these fibers out of a FM of the type illustrated in FIG. 8 is higher; therefore, graceful failure and higher toughness is achieved.

Alternatively, void space between juxtaposed round filaments are minimized if the round filaments are first flattened prior to firing (i.e., while the

organics are still present in the filaments.) Flattening can be accomplished by pressing or rolling. Inasmuch as the flattening process causes the filaments to take on a rectangular configuration, void spaces are removed. The resultant sheets can then be readily stacked.

5 The inventors also learned that cell phases which vary in cross section compared to boundary phase filaments can result in added strength to resulting fibrous monoliths. For example, rounding the "corners" of cell phase cross sections minimizes the severity of stress concentration points, thereby imparting higher strength to the cell phase during loading. A cross section of an exemplary
10 composite fiber is depicted in FIG. 9.

Generally, no limits on the radius of curvature are required. Preferably, however, the radius would fall into the following approximate range:

$$0.02 a \leq r \leq 0.2 a$$

whereby "a" is the dimension of the side of a polygon that is the cross section,
15 and "r" is the radius of curvature of the round corners of the cell phase. Setting r to be between 1/50 and 1/5 of a side is suitable.

The inventors found that triangles, squares, trapezoids, rectangles and hexagons are particularly suitable cross-section configurations for the cell phase.

Particle Preparation

Detail

20 A salient feature of the invented process is the production of FMs which are produced *in situ* from oxide powders. The graceful failure depicted by the invented FM is the result of tailoring particle sizes of the two constituents (i.e. the core or cell, and the sleeve or cell boundary phase). The inventors have found
25 that the density and relative strength between the core and sleeve phases is controlled by controlling particle sizes. To create the necessary microstructure of the resulting fibrous monoliths, the inventors utilized milling and settling techniques to create well-controlled particle size distributions. Generally, particle sizes of the constituents comprising the core material are smaller than the particle
30 sizes of the oxides comprising the sleeve material. Core particle sizes range from approximately 0.3 microns (μm) to 3 μm . The sleeve's oxide powders contain particle sizes ranging from 5 to 50 μm .

The powders of specific size become constituents in a first plastic formulation for the core extrusion process and a second plastic formulation for the sleeve extrusion process. Generally, each of the prepared powders were mixed with organics and vibratory milled for a time sufficient to create the desired particle sizes and dispersion. More detailed formulation details are provided in Example 1 below for $ZrSiO_4$ powders.

While the example contained herein deals with a $ZrSiO_4$ oxide, a myriad of oxides also are candidates for the plastic formulation process, including, but not limited to, Al_2O_3 , mullite, yttrium aluminum garnet, or combinations thereof.

Generally, materials exhibiting good high-temperature properties are suitable. Through doping and control of powder particle size, these materials are processed over a range of densities and strengths.

Reduction in the concentration of fine oxide powder in the cell boundaries further weaken the cell/boundary interface and promote additional delamination and deflection.

Residual Stress Detail

The inventors have found that residual stresses can be built into fibrous monoliths, leading to a substrate which arrests propagating cracks. Residual stresses are established when two materials are bonded well to each other and cool together from a processing temperature. If the materials have different coefficients of thermal expansion (CTEs), stresses are created.

Residual stresses arise from differences in thermal expansion coefficients between the cell and various surrounding layers in the fibrous monolith. The sum of the residual stresses will be zero. If residual stresses are engineered into strategic locations of a monolith, crack propagation can be arrested. A stress of approximately 1 GPa or greater can arrest a crack. More detailed discussion of engineering residual stresses in multilayered structures appears in D.J. Green et al., *Science* **283**, 1205-1297 (1999); and M.P. Rao et al. *Science* **286**, 102-104 (1999), and incorporated herein by reference. However, the application of residual stresses in fibrous monoliths are unknown.

Surprisingly and unexpectedly, the inventors found that residual stresses are established in FMs by controlling the concentration of oxides in the cell and boundary layers, and that a sintered fibrous monolith with these residual stresses can be prepared. These fibrous monoliths remained intact; the stresses did not induce failure. For example, controlling the concentration of such materials as aluminum oxides, mullite, zirconium oxide, or yttria-alumina garnet will modify the residual stresses. Generally, the materials are selected so that they (a) bond, (b) are compatible with each other, and (c) have CTEs that are the right difference ($CTE_{cell} - CTE_{boundary} = \Delta CTE$) so that for a given ratio of volume of cell to volume of boundary material and for a given sintering or processing temperature, the targeted residual stresses are established.

The inventors assume an average ΔT (processing temperature to room temperature) of approximately 1000 °C, with a range of between approximately 600-1600 °C. For any given ratio of cell to cell boundary (by volume fraction) the inventors have devised a ΔCTE range to provide the target stresses. Table 1 lists target coefficient of temperature expansion values for exemplary cell material/boundary material volume percents.

Table 1 Coefficient of Thermal Expansion for specific cell/boundary ratios

	<u>Ratio in Volume %</u>	<u>ΔCTE (°C⁻¹)</u>
20	90/10	0.2×10^{-6}
	80/20	0.9×10^{-6}
	70/30	2×10^{-6}
	60/40	3.7×10^{-6}

The values listed in Table 1 depend on the exact temperature and slightly on configuration. As such, the variability of the ΔCTE s listed may be as much as ± 50 percent. Table 2 below provides residual stress data for exemplary fibrous monoliths.

Table 2: Residual Stress data for selected fibrous monoliths.

	Core Material	Core CTE (1/°C)	Sheath Material	Sheath CTE (1/°C)	Volume Ratio (cell/sheath)	Resid. Stress Core (MPa) Tensile	Resid. Stress Sheath (Mpa) Compress.
5							
10	ZTM* (50/50) half-half by volume	8.75	MTA* 50/50 half-half by volume	7.55	70/30	1500	700
	ZTA*(10/90) 90% alumina by volume	9.44	MTA (50/50)	7.55	80/20	300	3100
	Alumina	9.2	Mullite	5.9	80/20	200	3400
15	ZTA (10/90)	9.44	MTA	8.87	80/20	120	1200
	Mullite	5.9	MTA (50/50)	7.55	80/20 70/30	540 1700	1900 900

* MTA = mullite + alumina; ZTM = yttria-stabilized zirconia + mullite; ZTA = Yttria-stabilized zirconia + alumina.

20 Cell- and Boundary-Phase Dimension Detail

Aside from manipulating the constituents of the two phases, or the shape of the two phases, the invented device facilitates rapid modification of the distances between the laminar phases and also the final extrusion shape of the composite fiber.

For example, the diameter of the core pin as seen in FIG. 1 is configured to provide the desired thickness of the boundary layer, defined as the thickness of the annular space between the pin and die 14. This annular space determines the thickness of the boundary layer surrounding the cell layer and therefore the area fractions of the core/sleeve phases. Typically, thicknesses of between approximately 0.01 millimeters (mm) and 0.1 mm for the boundary layer are targeted.

The utilization of a plurality of core pins will facilitate the extrusion of three, four, or multi-layer filaments. In such an instance, the pins are successively arranged coaxial with each other, so as to extend along the longitudinal axis of a longer die than typically used when just one pin is present.

5 For example, in the generation of a three-layer filament, a first pin would generate the starting cell phase. A second pin, proximal to the final exit point of the filament and therefore intermediate between the exit point and the first pin, is adapted to receive the just-produced two-phase filament to facilitate production of the three-layer filament. In essence, the second pin is arranged

10 "downstream" from the first pin.

In addition, and as also depicted in FIG. 1B, which is a view of FIG. 1 taken along line B-B, an end cap 13 of the die is configured to effect a desired cross section of the double-phase filament. FIG. 1B depicts a rectangular exit orifice of the die, therefore, resulting extruded double-phase filaments will be

15 rectangular in cross section.

Example 1

ZrSiO₄ powders were obtained from Alfa Aesar of Ward Hill, MA, and Remet of Utica, NY. The Alfa Aesar powder was utilized for the dense cell (i.e. core) and the Remet powder was used for the porous cell boundary. Each of

20 these powders was processed differently. The as-received Alfa Aesar powder had an average particle size of 1 μm. It was ball-milled in isopropyl alcohol with ZrO₂ milling media for 72 hours, then dried and screened through a 100-mesh (150 μm, or 0.0059 inches) sieve. The resulting particle size was 0.7 μm.

Remet flour-grade powder was first processed to remove the finest

25 particles. Three Remet powders were classified by sedimentation once, twice or thrice, with the average particle sizes for each of powders being 13.5 microns, 22 microns and 29 microns, respectively. The principal difference between the three powders is the fraction of fines that remain after settling. Approximately 100 grams of the Remet ZrSiO₄ powder, having an initial

particle size of 7 μm , was placed in a 1000 milliliter beaker with 800 milliliters of deionized water and 20 drops of a deflocculent (i.e., a dispersing agent.)

Darvan C, available from R.T. Vanderbilt Company, Inc., or Norwalk, CT is a suitable deflocculent. The solution was mixed for approximately one minute

5 and then allowed to stand for a time sufficient for the two phases to develop, which in this instance was approximately 3 minutes. The remaining solution was decanted and the settled material was retained. The settled powder had an average particle size of 13.5 microns.

After the ZrSiO_4 particles are sieved, their plastic processing begins.

10 In a first step of plastic processing, the necessary composition must be batched and then subjected to a vibratory or ball mill for a time sufficient to create an homogenous mixture. Table 3 shows the components and concentrations that were used in exemplary plastic mixes. Generally, the plastic mix constituents include the ceramic powders, a binder, a solvent, a plasticizer and a deflocculant. Generally, the binders serve to hold the particles together. A myriad of binders are commercially available and suitable for incorporation in the instant formulation. Suitable binders are medium to long-chain polymers with end functional groups. The ends attach to the powders and in so doing, provide a measure of strength to the mixture. AT-51 Binder from Rohm & Haas, Philadelphia, PA is one such suitable binder.

15 Plasticizers are utilized in the mix so as to modify the structure of the binder to make the later more flexible. An exemplary binder is butyl benzyl phthalate, marketed as S-160 Plasticizer from Monsanto, Fayetteville, NC. S-160 is a short-chained polymer.

25 Deflocculents prevent agglomeration of the powders by minimizing electrostatic attractions between the powders. Fish oil is a standard deflocculant,

Solvent is utilized to provide homogeneity to the organic mix. It is the vehicle in which the organic constituents dissolve. As such, a myriad of

solvents are suitable for the invented process. Xylene/butanol is an exemplary solvent.

Carbon powder is a constituent specific for the cell boundary slip. It serves to minimize the shrinkage differential between the cell phase and the boundary by leaving voids after burn off of the sleeve. The presence of the voids is short-lived inasmuch as the sleeve layer constituents cave in to fill the voids. The carbon also is used to differentiate the sleeve phase from the cell phase inasmuch as the ceramic powder is white and the carbon is black.

Table 3. Composition of plastic mixes used for extruding $ZrSiO_4$ filaments

10	<u>Constituent</u>	Alfa Aesar <u>$ZrSiO_4$ (g)</u>	Remet <u>$ZrSiO_4$ (g)</u>
	78 wt % xylene/22 wt % butanol	20	15
	Monsanto S-160 Plasticizer	10	10
	Dilute fish oil in xylene/butanol	10	10
15	$ZrSiO_4$ powder	200	200
	Rohm & Hass AT-51 Binder	21	21
	Carbon Powder	0	0.25 - 5

After the mixes were milled overnight, they were de-aired, tape cast to a thickness of approximately 0.5 mm, substantially dried and stripped. The tapes were allowed to sit overnight and were then mixed in a Brabender high-shear mixer. Mixing was used to adjust viscosity to the necessary levels for co-extrusion. Inasmuch as not all solvent is removed during the drying process, the "dried" mixes retained some flowability. Essentially, the drying increases viscosity of the mix.

In the co-extrusion process, depicted in FIG. 1, two Brabender screw extruders were attached to the co-extrusion die 14. The Alfa Aesar plastic mix was introduced into the first entry port 16 (i.e., a first extruder hopper) of the die and the Remet plastic mix was fed into a second entry port 18 (i.e. second extruder hopper) of the die. The two separate plastic mixes were simultaneously forced into the extrusion die to produce an initial filament 22.

The filaments were cut into 10 centimeter sections and bundled, as

depicted as element 24 in FIG 3. The bundle was then placed in an extrusion die and extruded to produce a fibrous monolith filament 28.

The fibrous monolith was cut into 50 mm sections, stacked in a bar die, and pressed in a bar die at a pressure of approximately 100 MPa. The resultant bars were then heat treated. Binder burnout was accomplished in flowing O₂ or N₂. Binder can be burned out in any oxidizing or inert atmosphere. Each bar was heated to 140 °C at 50 °C/hour and held for 0.1 hours. After the hold, each bar was heated to 500 °C at 5 °C/hour, held for 3 to 6 hours, and then cooled to room temperature at 50 °C/hour. The bars were sintered in air at 1550 °C for 3 hours to complete the processing of the ZrSiO₄ FMs.

Thermal expansion curves for 95 percent dense ZrSiO₄ (i.e., the core material) and 70 percent dense ZrSiO₄ (i.e., the sleeve material) are depicted in FIG. 5. These expansions are close enough such that thermal-expansion mismatch will not cause significant cracking of the FM. The FM bars exhibited a 23 volume percent shrinkage between initial pressing and the fired state.

The FM bars were approximately 70 volume percent cell (i.e., core) and 30 volume percent cell boundary (i.e., sleeve). This is lower than the ratio of 85 vol. percent cell and 15 vol. percent cell boundary generally observed for Si₃N₄/BN FMs. The average cell size (i.e. core diameter) of the ZrSiO₄/ZrSiO₄ FMs was approximately 150 microns.

The samples were loaded in an Instron Model 4505 tester, available from Instron Corporation, Canton, MA.

Scanning electron microscopy revealed a significant difference in shrinkage between the cell (i.e. core) and cell boundary (i.e., sleeve), with the cell shrinking more than the sleeve. This shrinkage will facilitate slippage at the interface between the two phases during a fracture. This, combined with a pull-out of individual cores, aid in dissipating energy.

The resulting FM product from the invented process confers several benefits, including being stable under oxidizing, inert and reducing

atmospheres. Inasmuch as it consists of one constituent, it is inherently stable over time.

Aside from the production of two-phase FMs, the inventors also have developed a three-phase FM which contains a cell, an interphase, and a matrix. The cell and interphase are made by co-extrusion. The matrix is the effect of a bundling of various filaments. The matrix also can be produced via various infiltration techniques.

A feature of the three-phase FM is that the weakest phase in the structure is not continuous. In a construct where non-continuous phases are utilized, any crack is isolated to a cell or group of cells. In such non-continuous phase structures, crack delamination, especially from out-of-plane loading, occurs discreetly from one cell to the next with each interphase acting as a crack trap. This differs from a continuous phase system wherein energy (manifested as a crack or delamination) traverses the entire structure. Thus, the advantage of this non-continuous construct is that greater strength and fracture toughness result.

While the invention has been described with reference to details of the illustrated embodiments, these details are not intended to limit the scope of the invention as defined in the appended claims. For example, while only two extruder hoppers are depicted in the instant filament-production process, additional hoppers could be added "downstream" from the point where the first sleeve is first laid down. As such, these third or fourth layers are applied distal to the first sleeve hopper, relative to the injection port utilized by the core material. This will facilitate the production of multiplex filaments such as triplex and quadraplex filaments. A head-on view of such a resulting filament would resemble a tree-ring configuration wherein the layers are concentrically aligned and co-axial to each other.

Also, while neat formulations of $ZrSiO_4$ were utilized in the examples herein, the utilization of this oxide, as well as other oxides, containing dopant is within the scope of the instant teaching. The addition of dopants, such as

yttrium oxide, boron oxide or boric acid, alkali metal hydroxides (such as sodium hydroxide), magnesium oxide, titanium dioxide and lead oxide further provide a wider range of densities for the core and cell boundary layers. Such dopants would be present in weight percents of approximately less than 2
5 weight percent.

CLAIMS

The embodiment of the invention in which an exclusive property or privilege is claimed is defined as follows:

- 1 1. A method for producing composite ceramics, the method
2 comprising
- 1 2. The method as recited in claim 1 wherein the filament and the
2 core are co-extruded in a continuous process.
- 1 3. The method as recited in claim 1 wherein the core and the sleeve
2 are comprised of identical compounds.
- 1 4. The method as recited in claim 1 wherein the core and sleeve are
2 comprised of compounds selected from the group consisting of $ZrSiO_4$, Al_2O_3 ,
3 mullite, yttrium aluminum garnet, or combinations thereof.
- 1 5. The method as recited in claim 2 further comprising:
2 a) forming material, comprising constituents of the core, into a
3 first plastic mass;
4 b) forming material comprising constituents of the sleeve into

5 a second plastic mass;

6 c) forcing the first plastic mass into a first entry port of a co-
7 extrusion dye while simultaneously forcing the second plastic mass into a
8 second entry port of the co-extrusion dye so as to produce a duplex filament
9 wherein the core is coaxial to and surrounded by the sleeve;

10 d) repeating steps a-c until a desired number of filaments are
11 produced;

12 e) subjecting the produced filaments to a ram extrusion
13 process to produce a fibrous monolith;

14 f) assembling the fibrous monoliths into a predetermined
15 shape; and

16 g) sintering the assembled fibrous monoliths.

1 6. The method as recited in claim 5 wherein the produced filaments
2 are arranged parallel with each other prior to the ram extrusion process so as to
3 produce a unidirectional fibrous monolith.

1 7. The method as recited in claim 5 wherein the produced filaments
2 are arranged at various angles to each other to form a multidirectional fibrous
3 monolith.

1 8. The method as recited in claim 5 wherein the fibrous monoliths
2 are arranged in a configuration so that fibrous monoliths in a peripheral region
3 of the configuration is comprised of 60-90 volume percent of the first plastic
4 mass and fibrous monoliths in a region medially directed from the peripheral
5 region have at least 5 percent lower volume percent of the first plastic mass.

1 9. The method as recited in claim 5 wherein the first plastic material
2 is formed by

3 a) sizing compounds comprising the core to between 0.3

4 microns and 3 microns in diameter;

5 b) mixing the sized compounds with plasticizer, solvent and
6 binder so as to form a slurry; and

7 c) homogenizing the slurry.

1 10. The method as recited in claim 5 wherein the second plastic
2 material is formed by

3 a) sizing compounds comprising the sleeve to between 5 and
4 50 microns in diameter;

5 b) mixing the sized compounds with plasticizer, solvent,
6 binder and carbon so as to form a slurry; and

7 c) homogenizing the slurry.

1 11. The method as recited in claim 5 wherein the constituents of the
2 core comprise particles having diameters of between 0.3 microns and 3
3 microns.

1 12. The method as recited in claim 5 wherein the constituents of the
2 sleeve comprise particles having diameters of greater than 5 microns and less
3 than 30 microns.

1 13. The method as recited in claim 1 wherein the core comprises
2 particles and the sleeve comprises particles and wherein the particles of the
3 core have a smaller diameter than the particles of the sleeve.

1 14. The method as recited in claim 5 wherein the filaments have a
2 circular cross section.

1 15. The method as recited in claim 5 wherein the filaments have a
2 rectangular cross section.

1 16. The method as recited in claim 5 wherein the cross section of the
2 core contains round corners.

1 17. The method as recited in claim 5 wherein the cross section of the
2 sleeve contains angular corners.

1 18. The method as recited in claim 6 wherein the filaments have a
2 circular cross section and the filaments are flattened after being arranged, to a
3 configuration sufficient to cause the cross section to approximate a rectangle.

1 19. The method as recited in claim 5 wherein a third plastic mass is
2 applied to the sleeve at a first point distal from the second entry point so as to
3 produce a second sleeve concentric with the core.

1 20. The method as recited in claim 19 wherein a fourth plastic mass is
2 applied to the second sleeve at a second point distal from the first point.

1 21. The method as recited in claim 5 wherein the core contains
2 tensile residual stress and the sleeve has a compressive stress that is
3 sufficiently large to arrest crack propagation when the composite ceramic is put
4 under load.

1 22. A fibrous monolith comprising a plurality of multi-phase filaments
2 arranged in a configuration to cause graceful failure of the monolith when the
3 monolith is placed under mechanical stress.

1 23. The monolith as recited in claim 22 wherein the filaments each
2 have a first phase and a second phase, whereby the second phase is
3 peripherally arranged about the first phase and coaxial to the first phase.

1 24. The monolith as recited in claim 23 wherein the volume percent of
2 second phase in filaments comprising an inner region of the monolith is higher
3 than the volume percent of second phase in filaments comprising a peripheral
4 region of the monolith.

1 25. The monolith as recited in claim 23 wherein the first phase has a
2 cross section containing rounded corners.

1 26. The monolith as recited in claim 23 wherein the second phase
2 has a cross section containing angular corners.

1 27. The monolith as recited in claim 23 wherein the first phase has a
2 cross section containing rounded corners and the second phase has a cross
3 section containing angular corners.

1 28. The monolith as recited in claim 22 wherein no space exists
2 between the arranged filaments.

1 29. The monolith as recited in claim 22 wherein the filaments have
2 cross sections resembling triangles or squares or rectangles or trapezoids or
3 hexagons or combinations thereof.

1 30. The monolith as recited in claim 23 wherein the first phase and
2 the second phase contain oxides selected from the group consisting of $ZrSiO_4$,
3 Al_2O_3 , mullite, yttrium aluminum garnet, or combinations thereof.

1 31. A fibrous monolith comprising a plurality of two-phase filaments
2 containing $ZrSiO_4$.

1 32. The monolith as recited in claim 31 wherein in each filament, the
2 two phases are concentrically arranged relative to each other extend along the
3 longitudinal axis of the filament.

1 33. The monolith as recited in claim 31 wherein the filaments have
2 crosssections resembling triangles or squares or rectangles or trapezoids or
3 hexagons or combinations thereof of the filaments.

Fig. 1

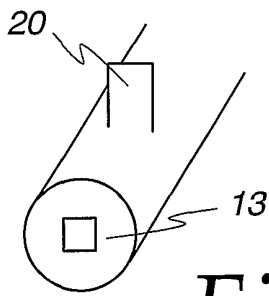
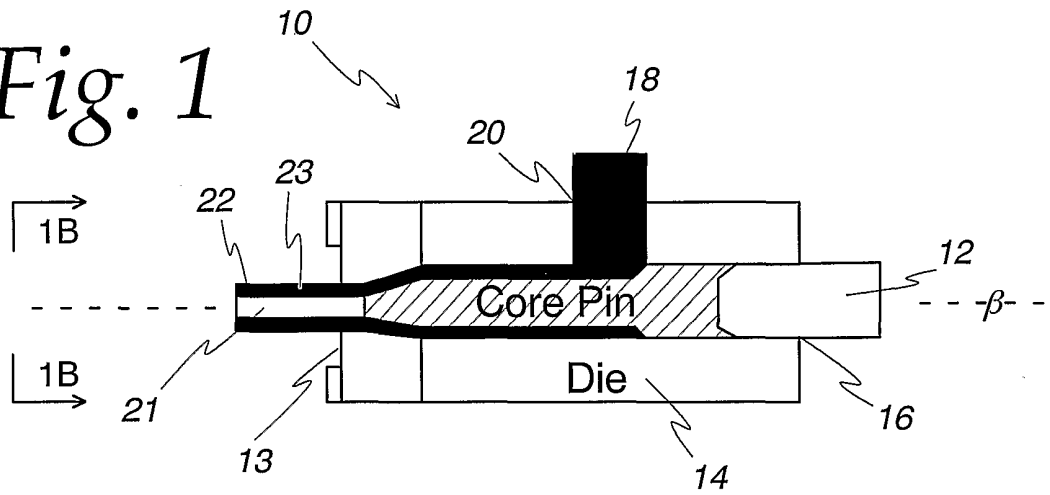

Fig. 1B

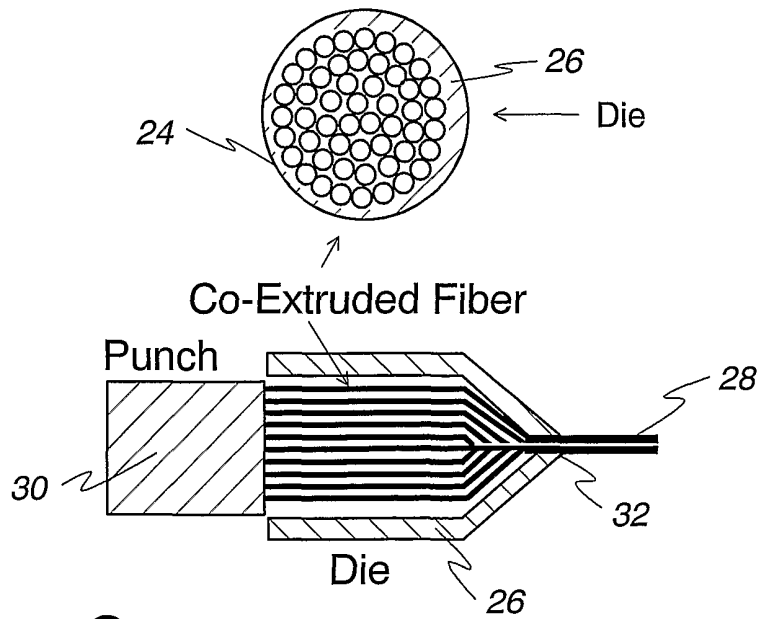

Fig. 2

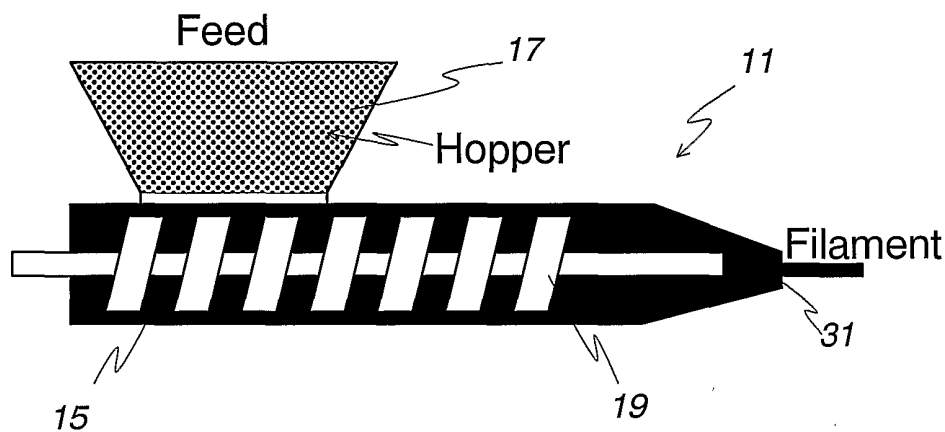

Fig. 1c

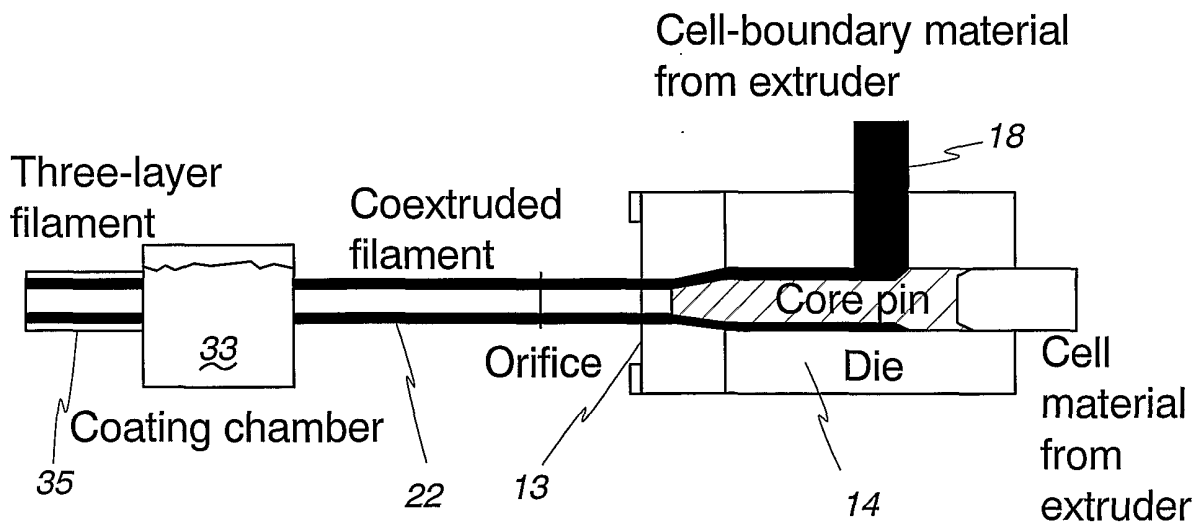

Fig. 1d

3/6

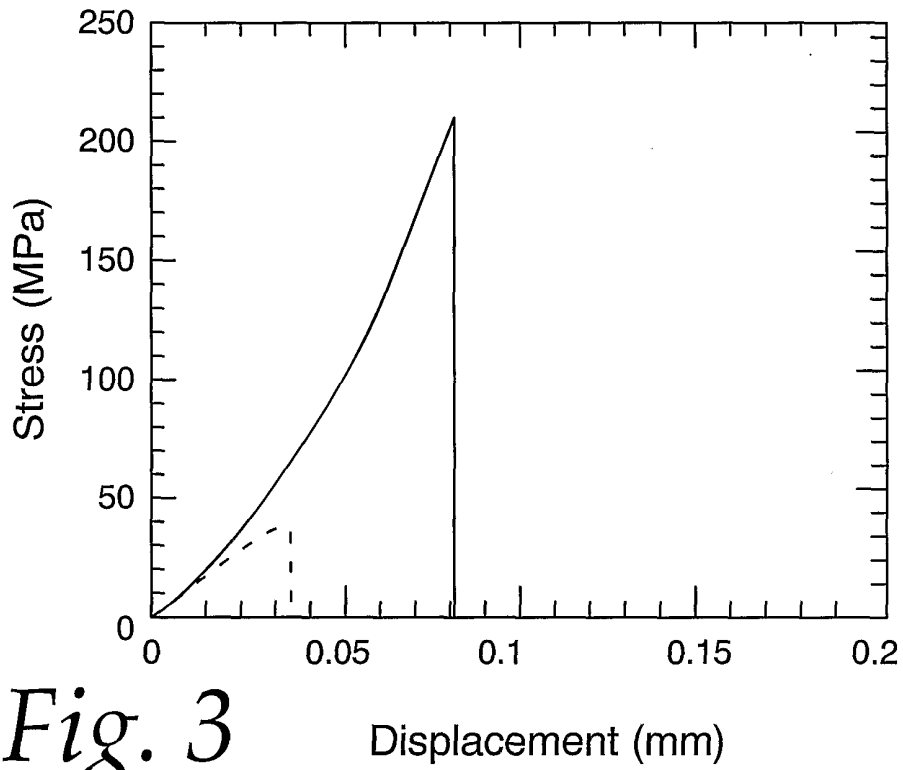

Fig. 3

Displacement (mm)

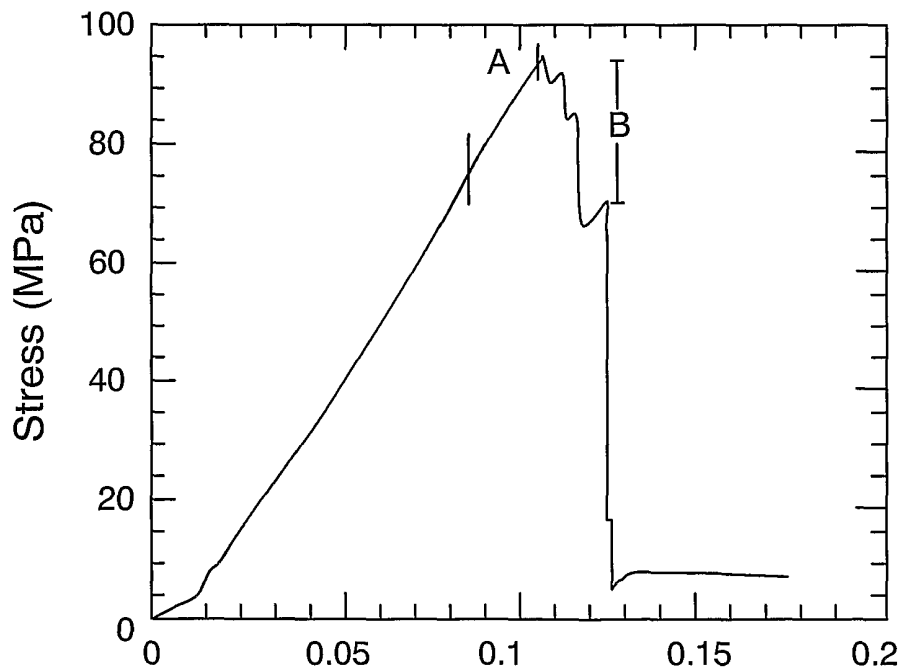

Fig. 4

Displacement (mm)

4/6

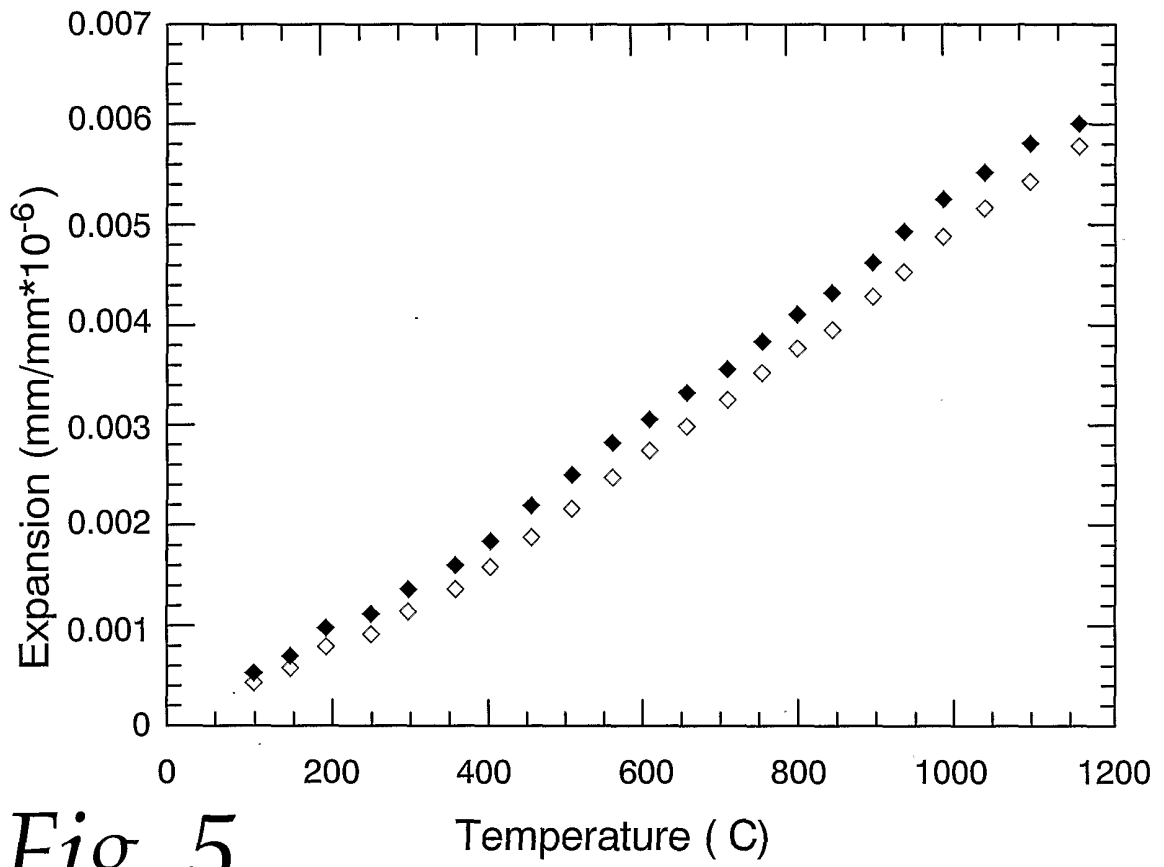

Fig. 5

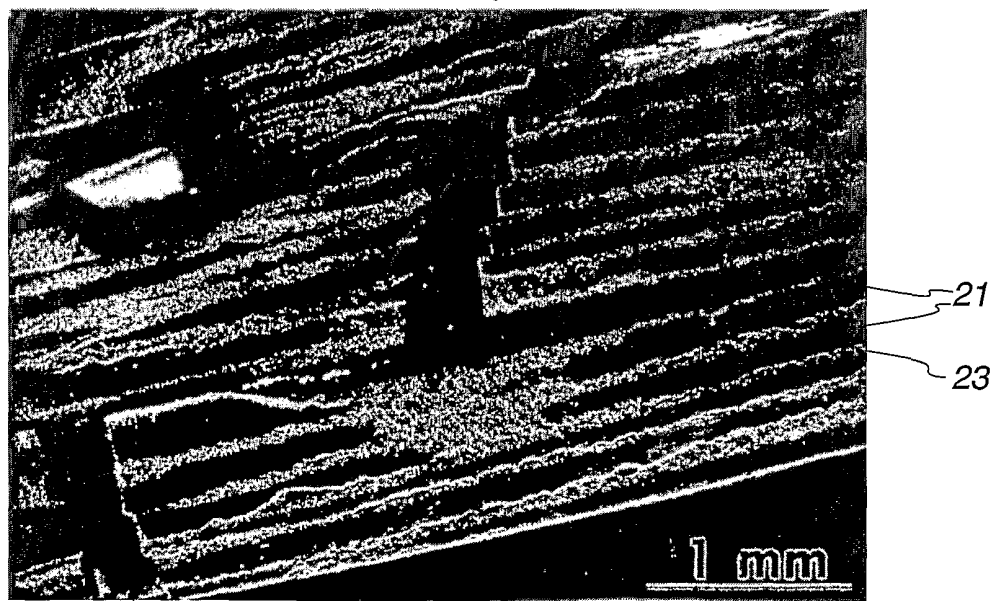

Fig. 6

5/6

Fig. 7

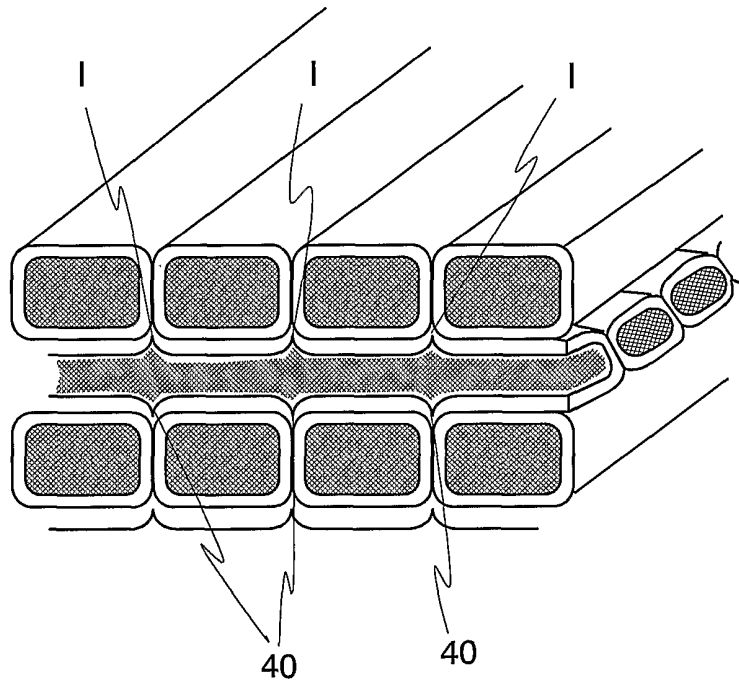

Fig. 8

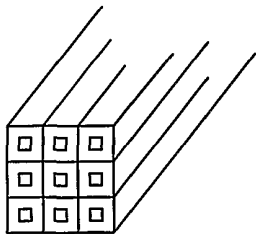

Fig. 9

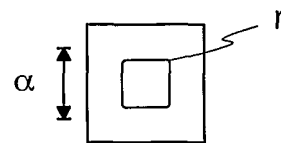
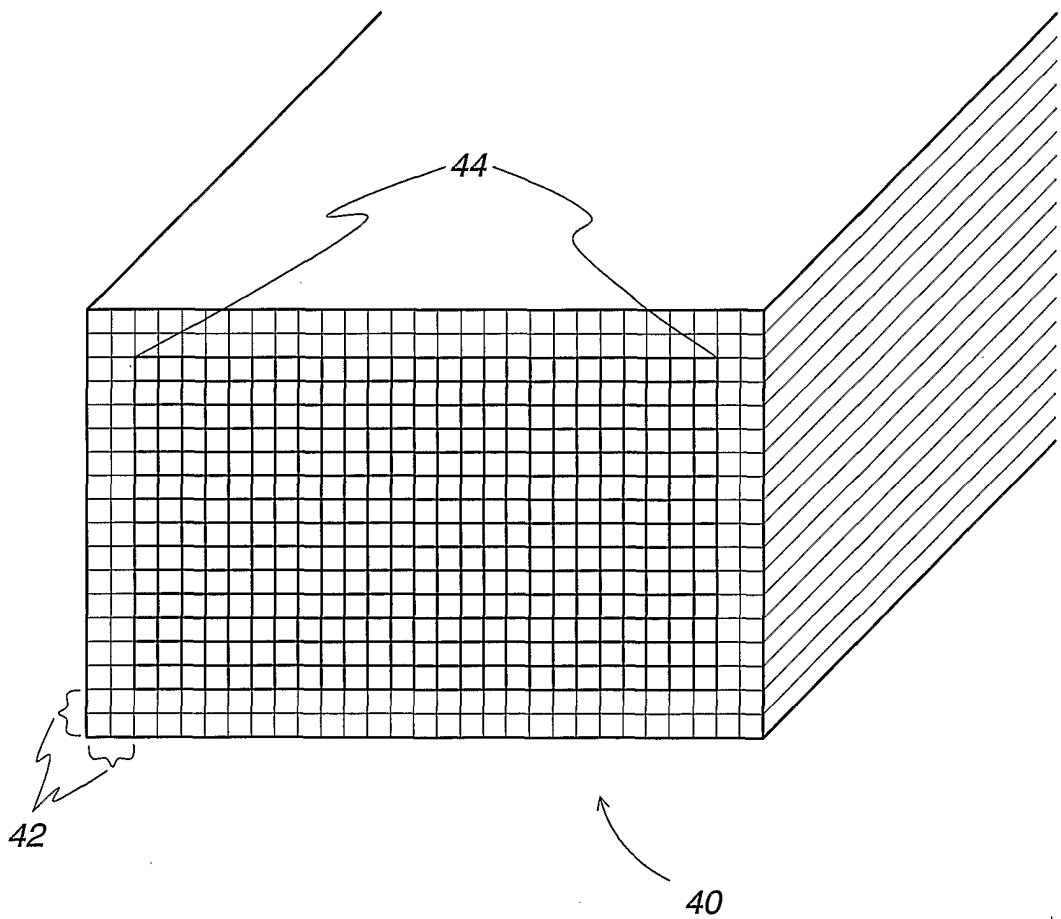

Fig. 10



INTERNATIONAL SEARCH REPORT

International application No.
PCT/US01/02140

A. CLASSIFICATION OF SUBJECT MATTER

IPC(7) :B29C 47/06; CO4B 35/80
US CL :264/638, 177.1, 177.11, 211.11; 428/113; 501/95.1, 95.2

According to International Patent Classification (IPC) or to both national classification and IPC

B. FIELDS SEARCHED

Minimum documentation searched (classification system followed by classification symbols)

U.S. : 264/627, 638, 639, 177.1, 177.11, 211.11; 428/107, 109, 113, 699, 701; 501/95.1, 95.2

Documentation searched other than minimum documentation to the extent that such documents are included in the fields searched

Electronic data base consulted during the international search (name of data base and, where practicable, search terms used)

C. DOCUMENTS CONSIDERED TO BE RELEVANT

Category*	Citation of document, with indication, where appropriate, of the relevant passages	Relevant to claim No.
X ---- Y	US 5,645,781 A (POPOVIC' et al) 08 July 1997, see entire document, especially Abstract and examples	1-2, 4, and 22-23 ---- 5-21, 24-33
X ---- Y	US 5,783,139 A (CURRAN et al) 21 July 1998, see entire document, especially the Abstract and Col. 7, lines 6-16	1-3 ---- 5-21, 24-33
Y	US 4,772,524 A (COBLENZ) 20 September 1988, see entire document	22-33
Y	US 4,824,623 A (RAMBOSEK) 25 April 1989, see entire document	30-31
Y	US 3,709,706 A (SOWMAN) 09 January 1973, see entire document	30-31

Further documents are listed in the continuation of Box C. See patent family annex.

* Special categories of cited documents:	"T" later document published after the international filing date or priority date and not in conflict with the application but cited to understand the principle or theory underlying the invention
"A" document defining the general state of the art which is not considered to be of particular relevance	"X" document of particular relevance; the claimed invention cannot be considered novel or cannot be considered to involve an inventive step when the document is taken alone
"E" earlier document published on or after the international filing date	"Y" document of particular relevance; the claimed invention cannot be considered to involve an inventive step when the document is combined with one or more other such documents, such combination being obvious to a person skilled in the art
"L" document which may throw doubts on priority claim(s) or which is cited to establish the publication date of another citation or other special reason (as specified)	"&" document member of the same patent family
"O" document referring to an oral disclosure, use, exhibition or other means	
"P" document published prior to the international filing date but later than the priority date claimed	

Date of the actual completion of the international search

04 APRIL 2001

Date of mailing of the international search report

APR 30 2001

Name and mailing address of the ISA/US
Commissioner of Patents and Trademarks
Box PCT
Washington, D.C. 20231

Facsimile No. (703) 305-3230

Authorized officer

JAMES DERRINGTON

Telephone No. (703) 308-3832

INTERNATIONAL SEARCH REPORT

International application No.

PCT/US01/02140

Box I Observations where certain claims were found unsearchable (Continuation of item 1 of first sheet)

This international report has not been established in respect of certain claims under Article 17(2)(a) for the following reasons:

1. Claims Nos.:
because they relate to subject matter not required to be searched by this Authority, namely:

2. Claims Nos.:
because they relate to parts of the international application that do not comply with the prescribed requirements to such an extent that no meaningful international search can be carried out, specifically:

3. Claims Nos.:
because they are dependent claims and are not drafted in accordance with the second and third sentences of Rule 6.4(a).

Box II Observations where unity of invention is lacking (Continuation of item 2 of first sheet)

This International Searching Authority found multiple inventions in this international application, as follows:

Please See Extra Sheet.

1. As all required additional search fees were timely paid by the applicant, this international search report covers all searchable claims.
2. As all searchable claims could be searched without effort justifying an additional fee, this Authority did not invite payment of any additional fee.
3. As only some of the required additional search fees were timely paid by the applicant, this international search report covers only those claims for which fees were paid, specifically claims Nos.:

4. No required additional search fees were timely paid by the applicant. Consequently, this international search report is restricted to the invention first mentioned in the claims; it is covered by claims Nos.:

Remark on Protest

The additional search fees were accompanied by the applicant's protest.

No protest accompanied the payment of additional search fees.

INTERNATIONAL SEARCH REPORT

International application No.
PCT/US01/02140

BOX II. OBSERVATIONS WHERE UNITY OF INVENTION WAS LACKING

This ISA found multiple inventions as follows:

This application contains the following inventions or groups of inventions which are not so linked as to form a single inventive concept under PCT Rule 13.1. In order for all inventions to be searched, the appropriate additional search fees must be paid.

Group I, claim(s)1-21, drawn to a method.

Group II, claim(s)22-33, drawn to an article.

The inventions listed as Groups I and II do not relate to a single inventive concept under PCT Rule 13.1 because, under PCT Rule 13.2, they lack the same or corresponding special technical features for the following reasons: The special technical feature of simultaneously forming a ceramic core coaxial with a ceramic sleeve as recited in Group I is not recited in Group II. The special technical feature of a monolith having a configuration to cause graceful failure when under mechanical stress as recited in Group II is not recited in Group I.