

(21) Application No: **2404132.9**
 (22) Date of Filing: **14.10.2022**
 Date Lodged: **22.03.2024**
 (30) Priority Data:
 (31) **63256521** (32) **15.10.2021** (33) **US**
 (62) Divided from Application No **2309269.5** under section 15(9) of the Patents Act 1977

(51) INT CL:
A43B 23/17 (2006.01) **A43B 11/02** (2006.01)
A43B 21/32 (2006.01) **A43B 23/08** (2006.01)

(56) Documents Cited:
CN 109393642 A **US 6880272 A1**

(58) Field of Search:
 INT CL **A43B**
 Other: **SEARCH-PATENT**

(71) Applicant(s):
Skechers U.S.A., Inc. II
228 Manhattan Beach Blvd., Manhattan Beach 90266,
California, United States of America

(72) Inventor(s):
John Maxwell Weeks
Scott Kelley
Frank F Chuang
Pei-Chun Liao
Hui Xie
Kurt Stockbridge
Johnson Tja

(74) Agent and/or Address for Service:
D Young & Co LLP
3 Noble Street, LONDON, EC2V 7BQ, United Kingdom

(54) Title of the Invention: **Footwear counter for easier entry and removal**
 Abstract Title: **Footwear with flexible heel cup**

(57) A shoe comprising a heel cup 52 moulded with an upper portion 64, midportion 58, and lower portion 54, the upper portion having a smaller mediolateral length than the midportion, and the rearmost portion of the heel cup having an S wave shape in a vertical cross section. In the cross section, an area of the midportion has a smaller thickness than one or more of an area of the upper and lower portion, the midportion providing flexibility of the heel cup. The heel cup is preferably compressible. The upper portion of the heel cup may have a first configuration and is configured to be distorted into a second configuration under a load of a foot when it is inserted into the shoe. Once the load is removed the upper portion may return to the first configuration. The medial and lateral sides of the heel cup may expand outwardly in the second configuration. Preferably the heel cup is attached to an interior foam layer (92, fig. 9) that may form part of the cuff of the shoe opening.

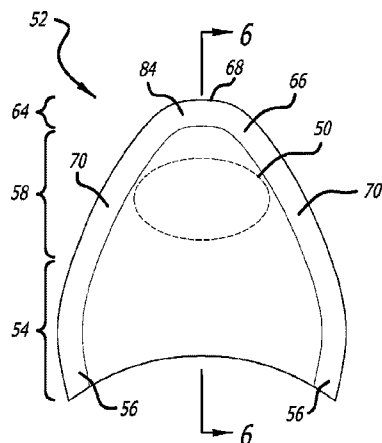

FIG. 1

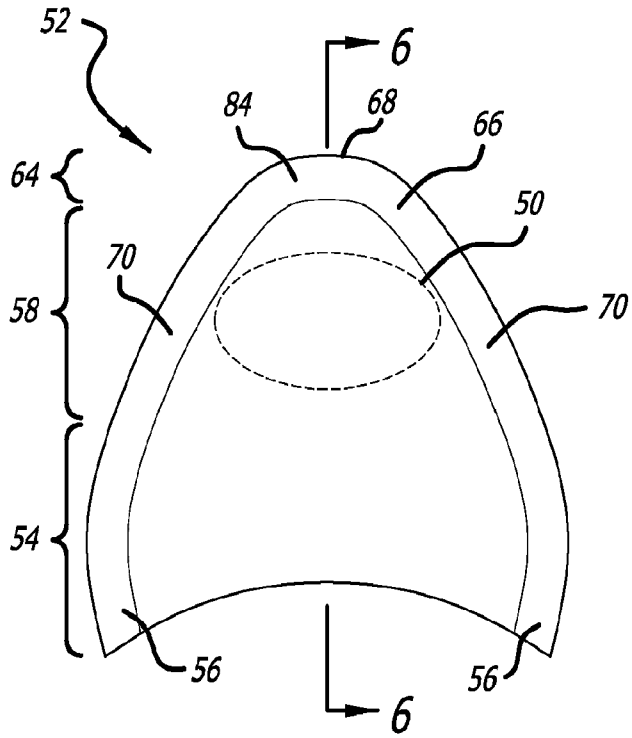

FIG. 1

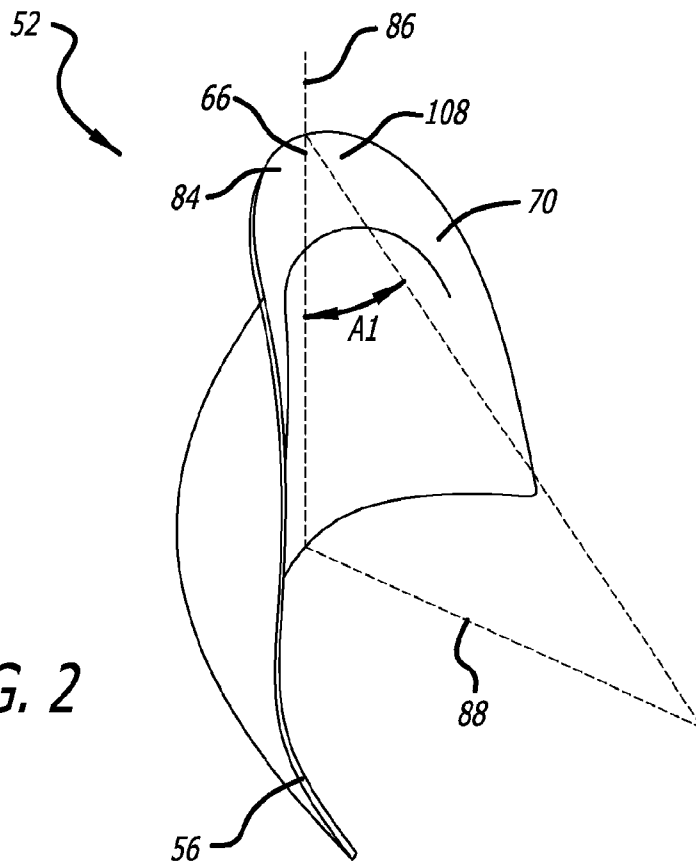

FIG. 2

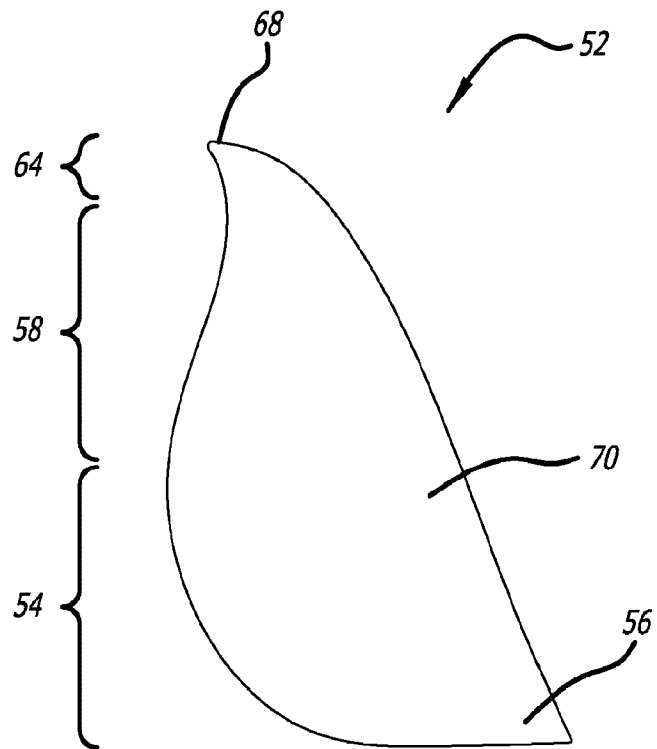

FIG. 3

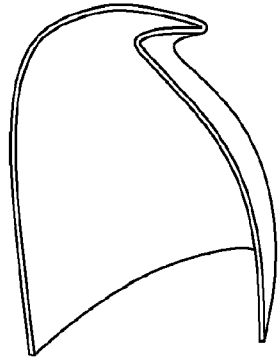

FIG. 4A

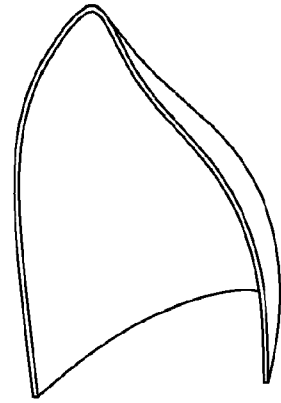

FIG. 4B

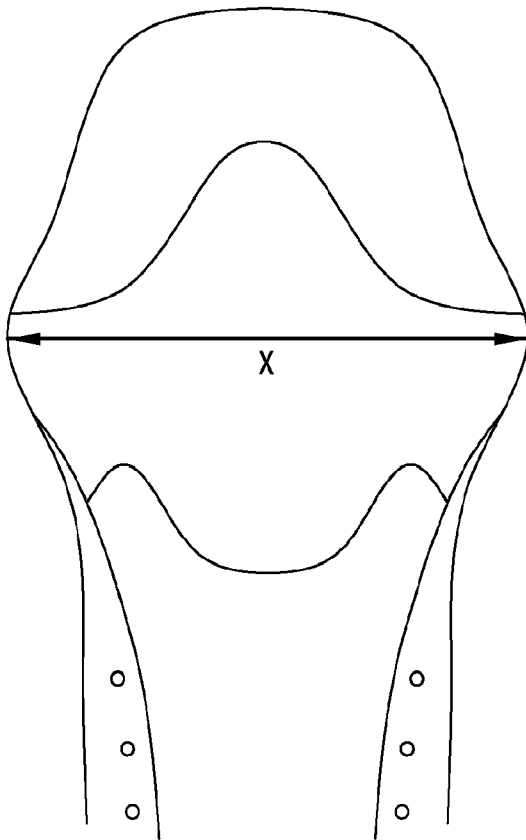

FIG. 4C

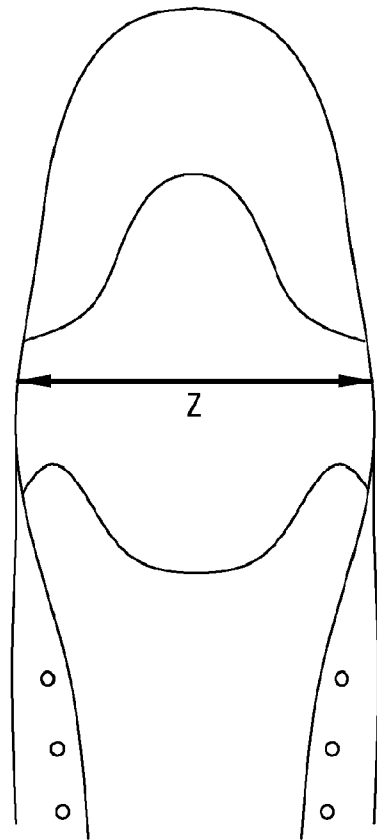

FIG. 4D

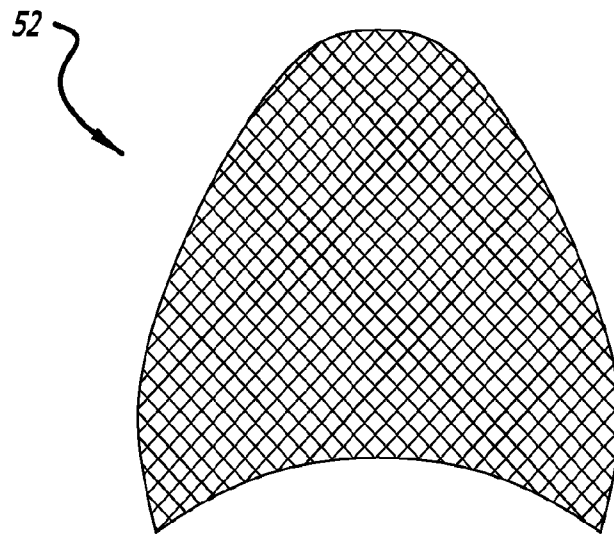

FIG. 5

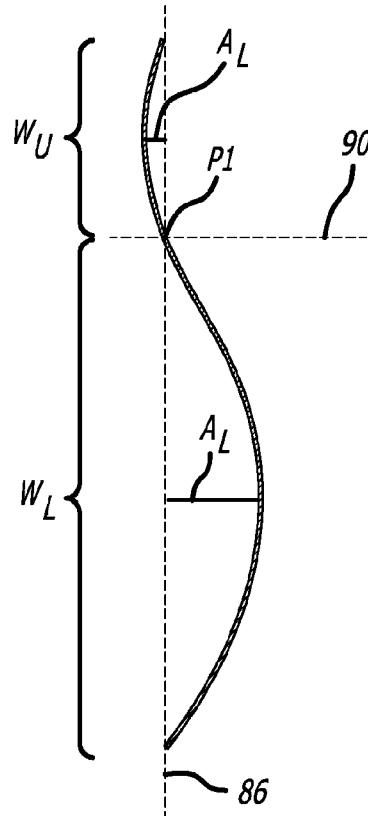

FIG. 6A

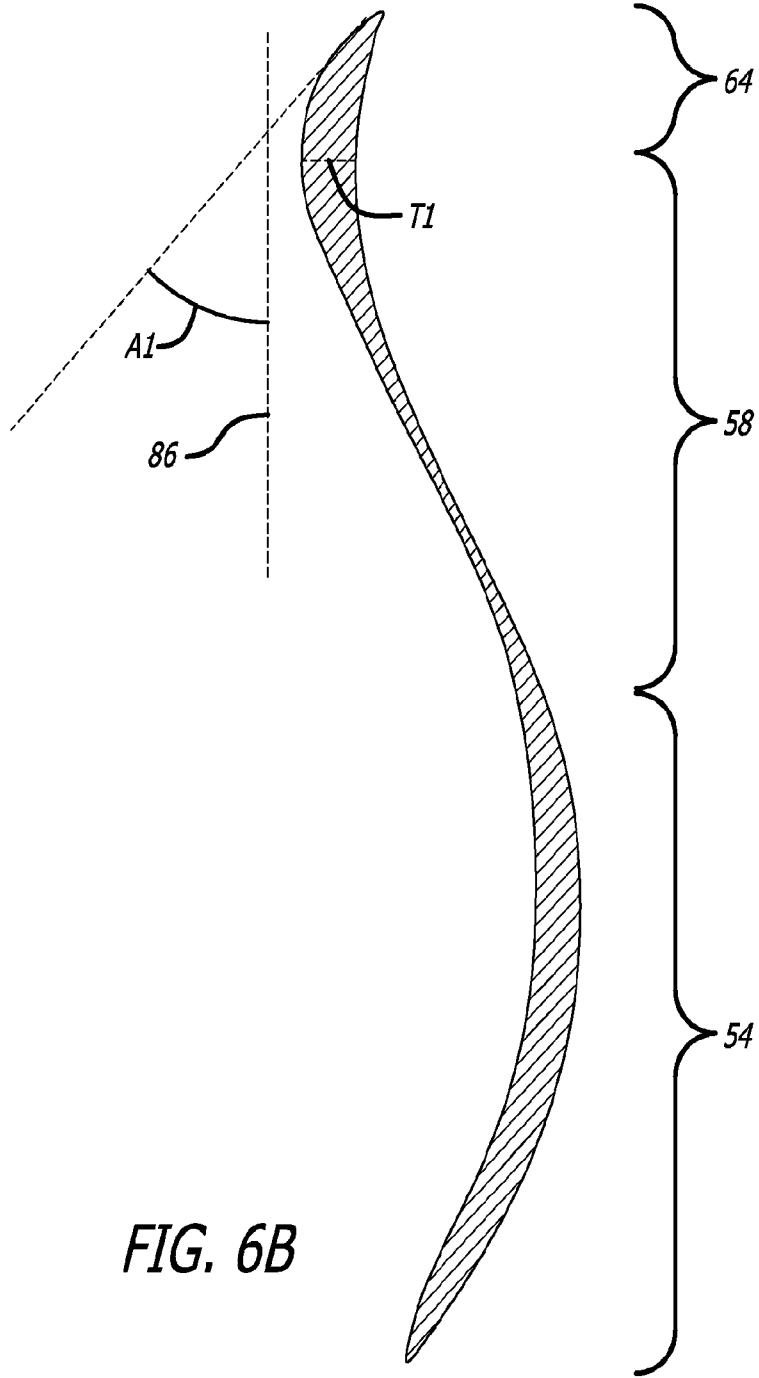
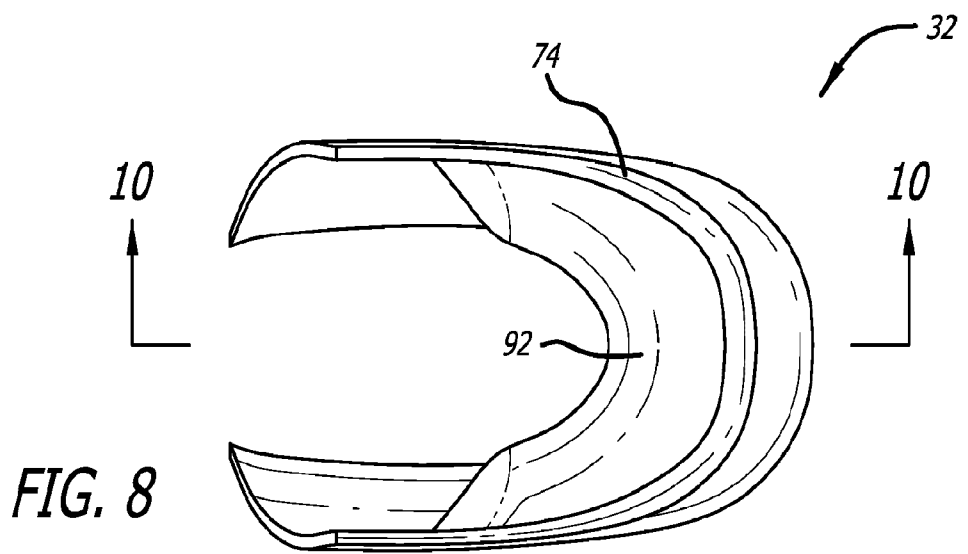
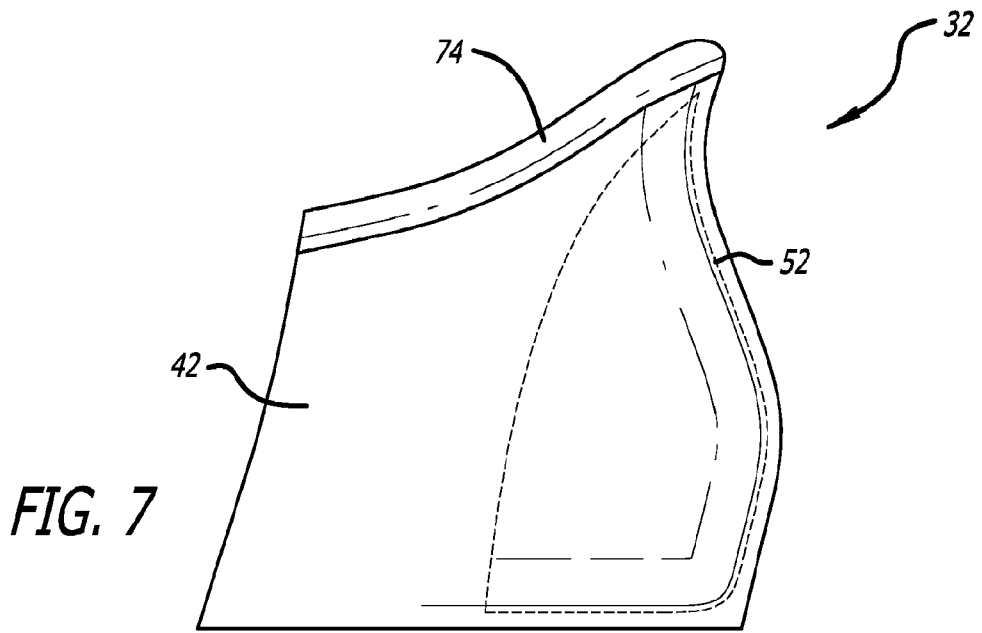
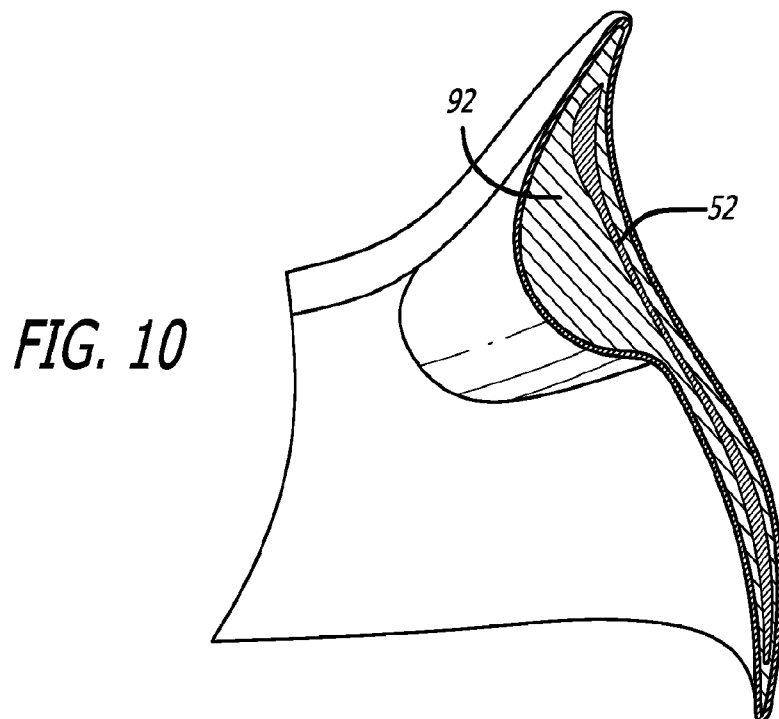
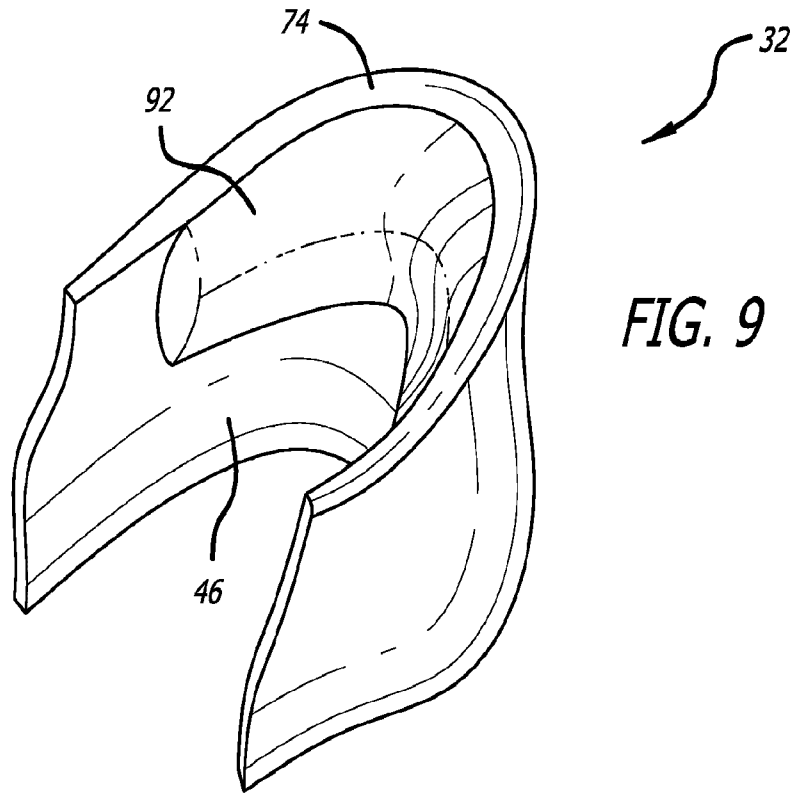
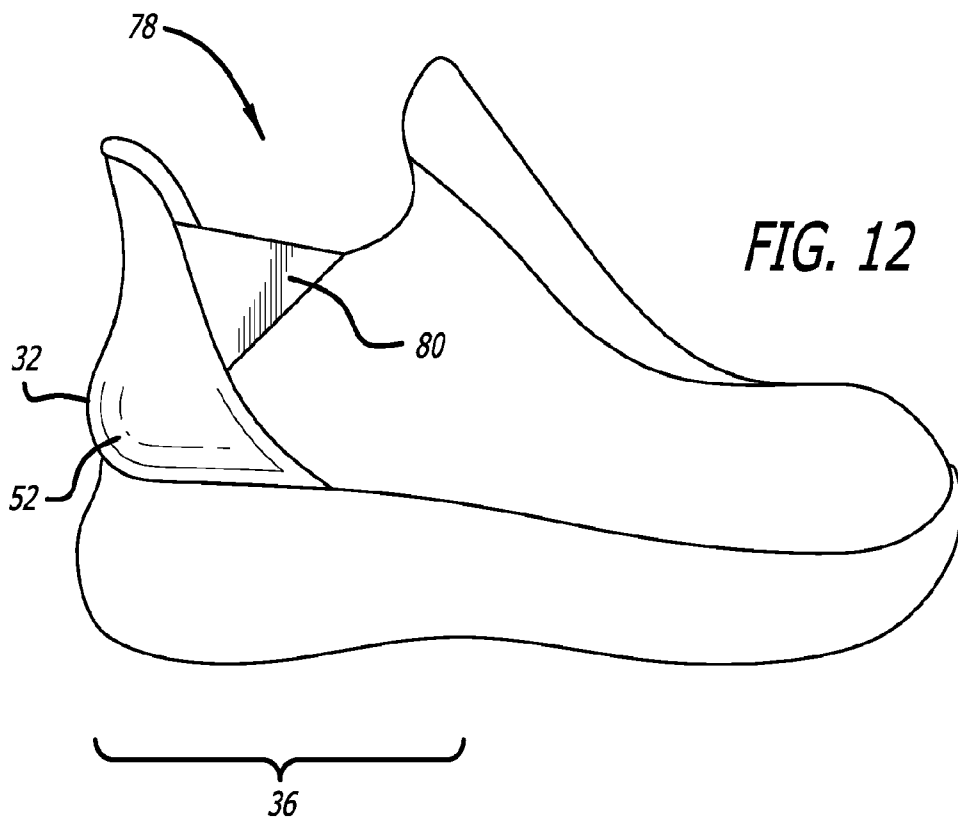
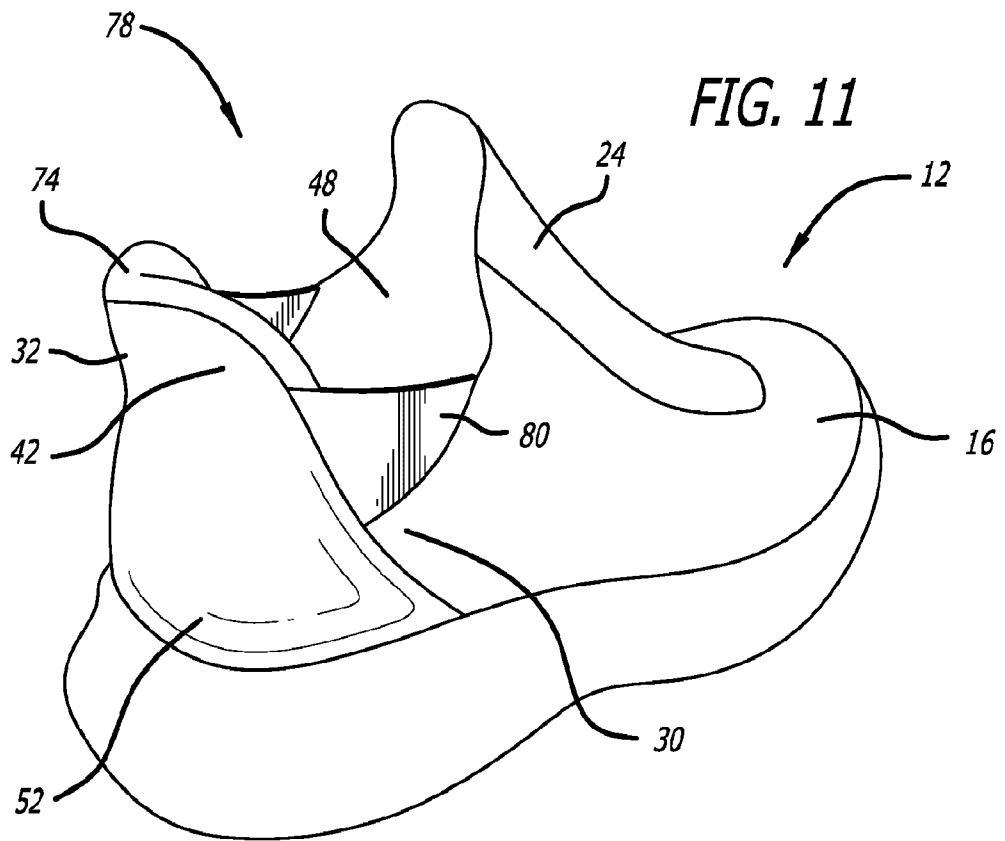

FIG. 6B







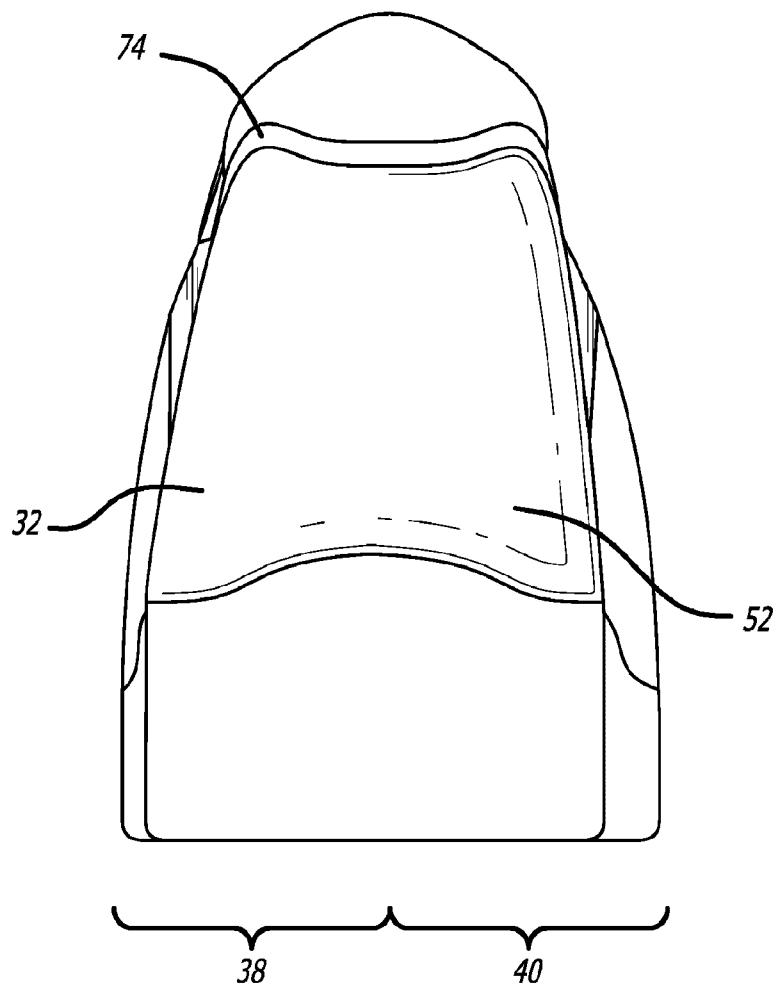

FIG. 13

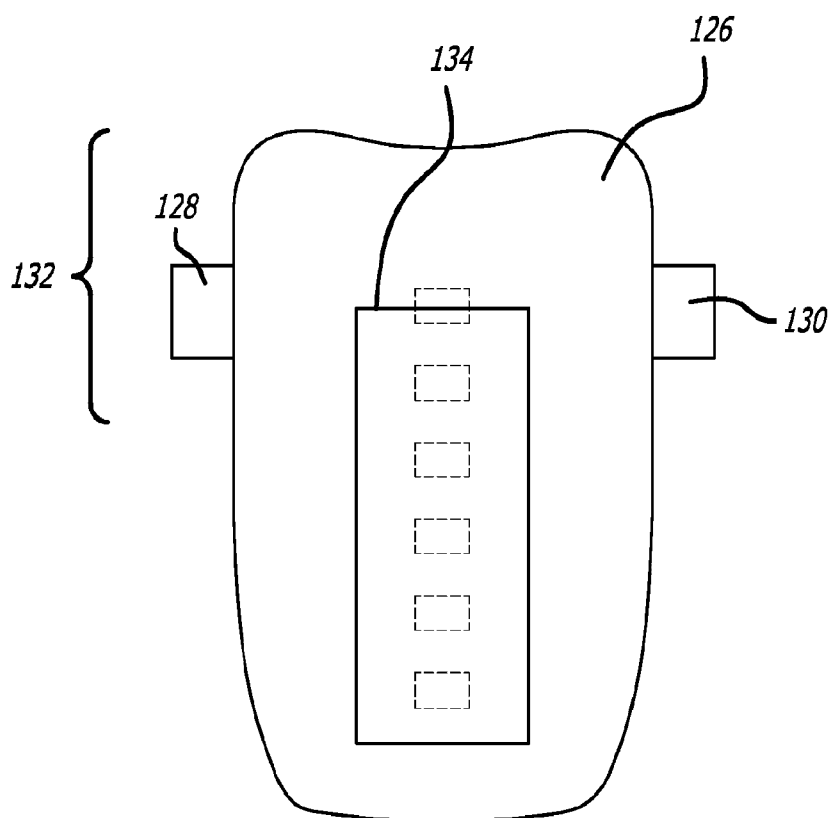
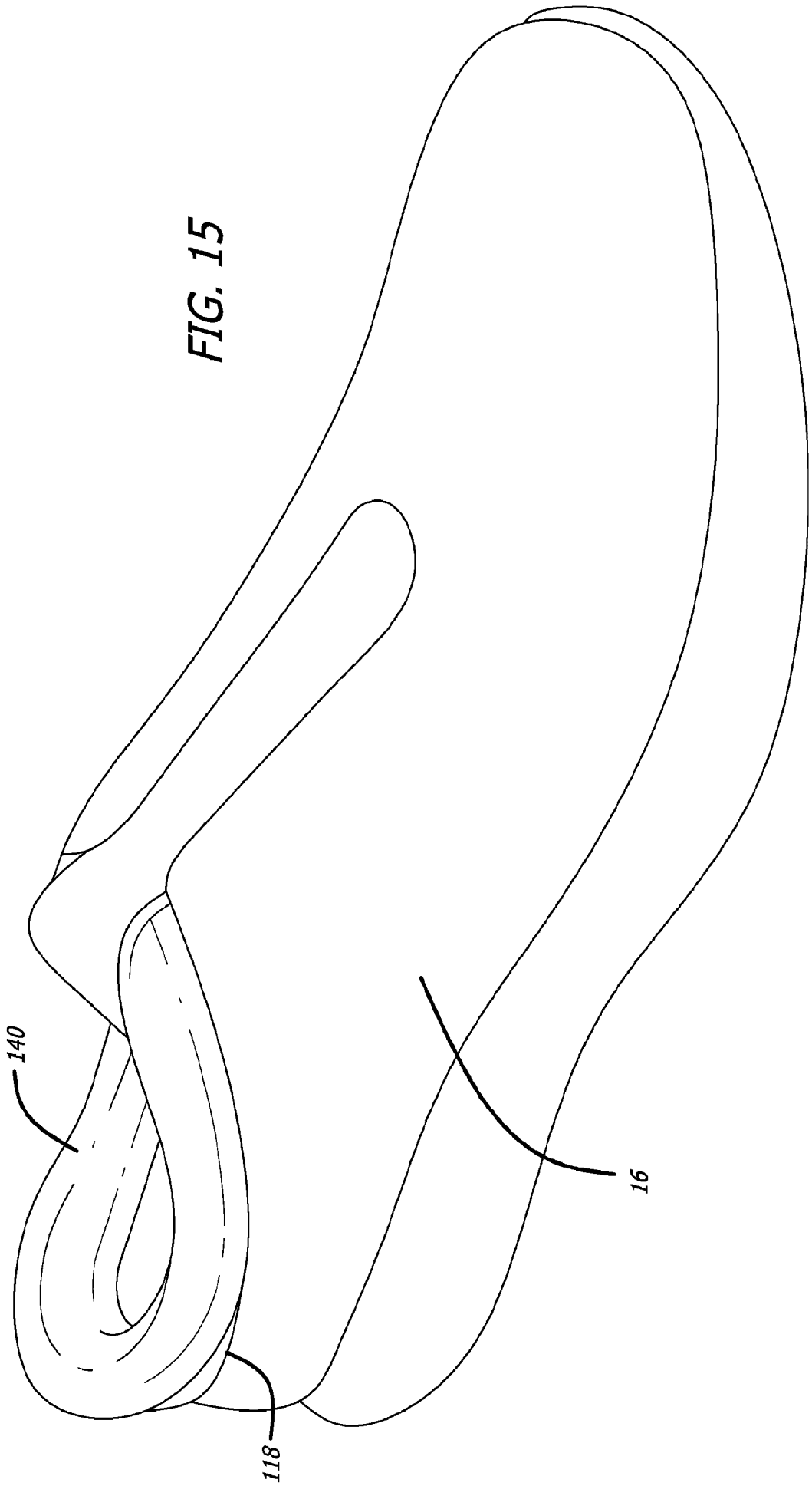

FIG. 14

FIG. 15



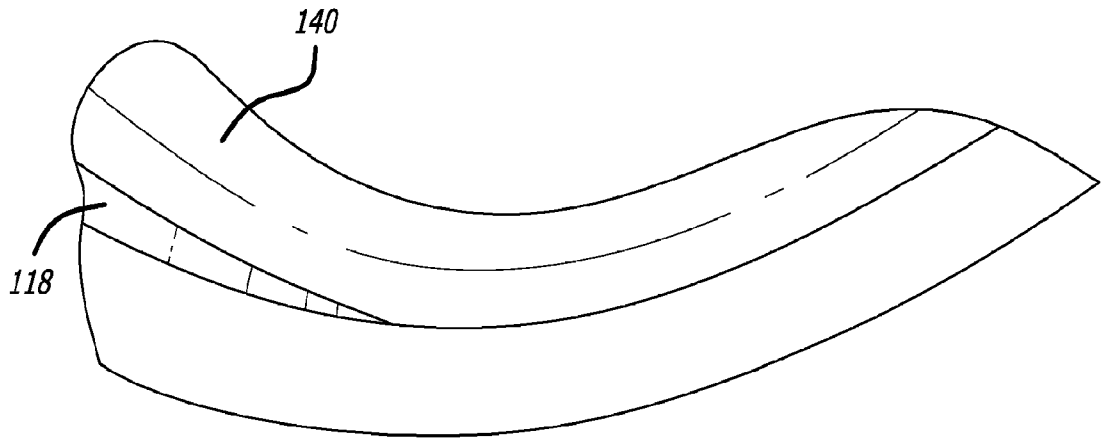

FIG. 16

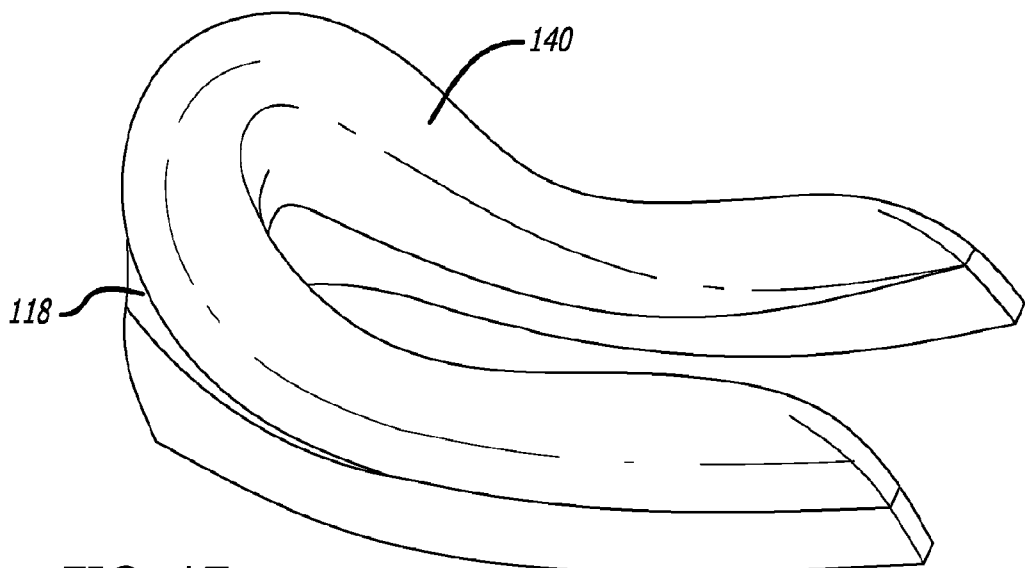

FIG. 17

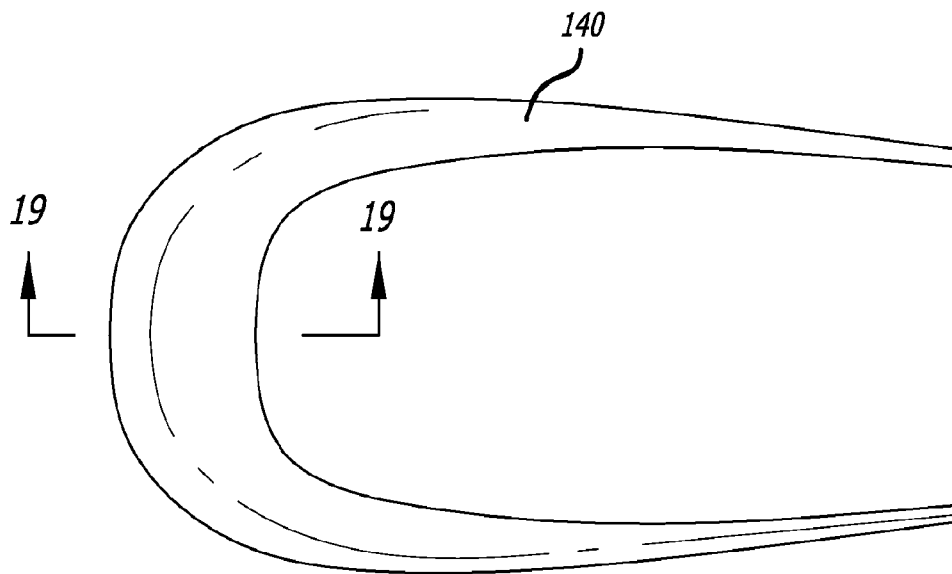

FIG. 18

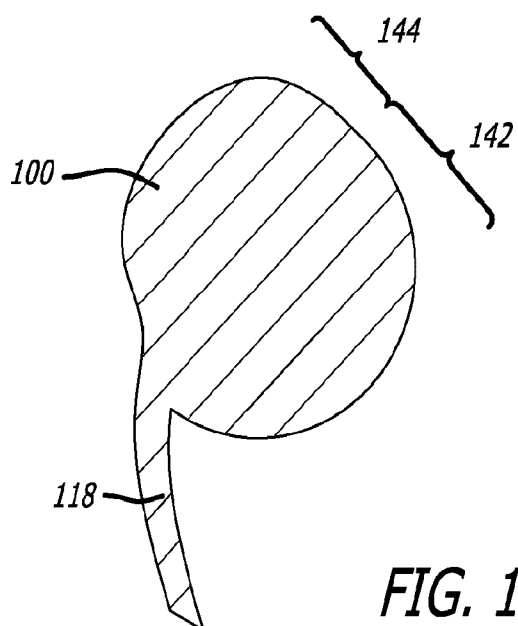

FIG. 19

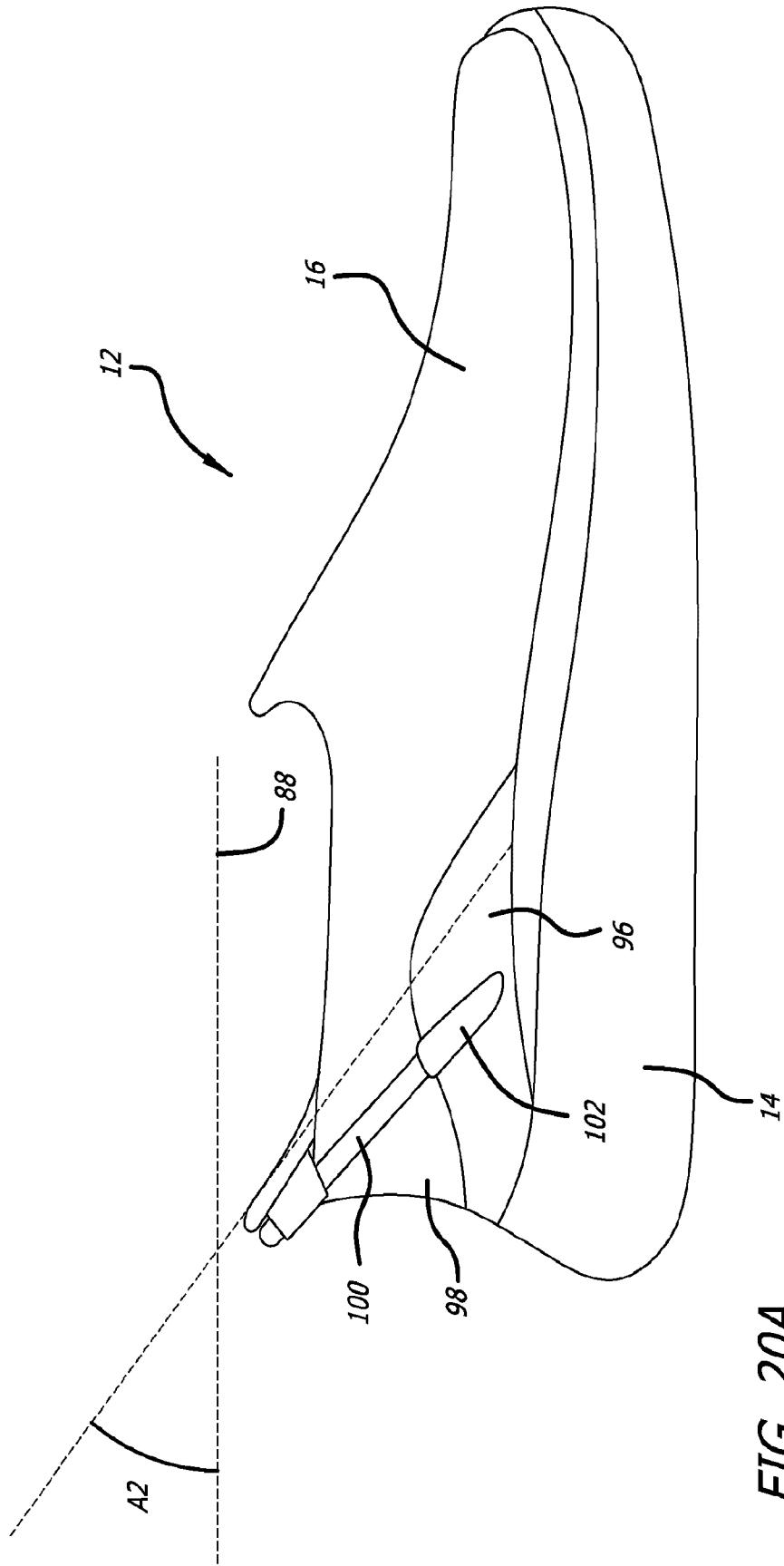

FIG. 20A

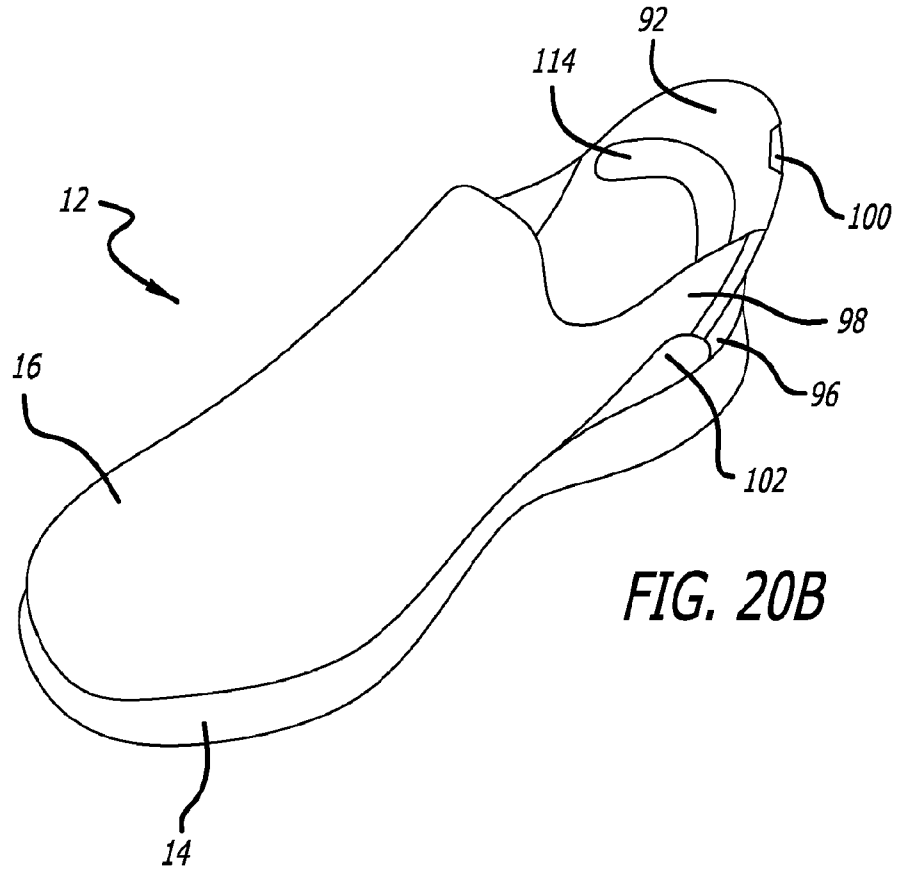

FIG. 20B

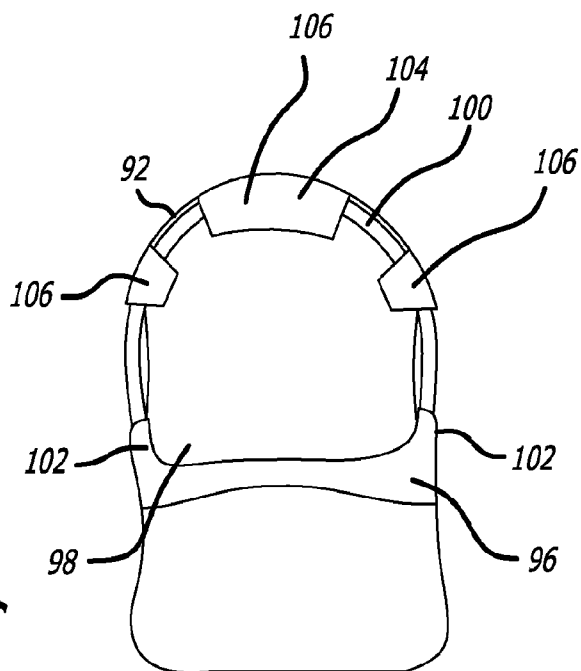

FIG. 20C

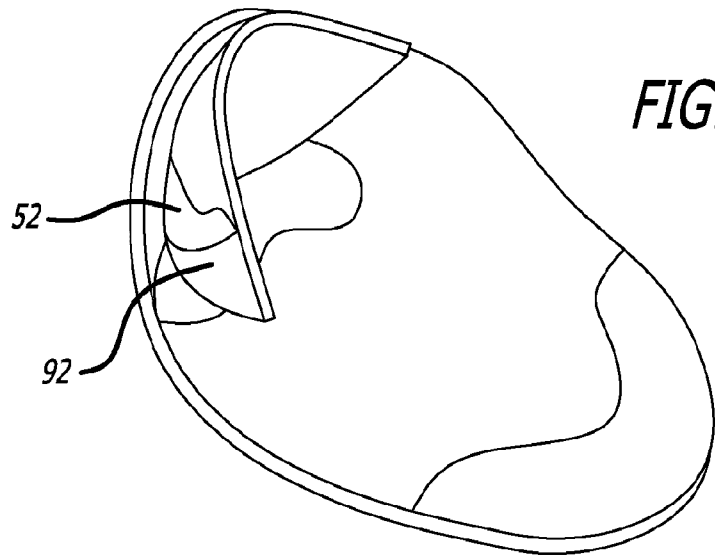

FIG. 21

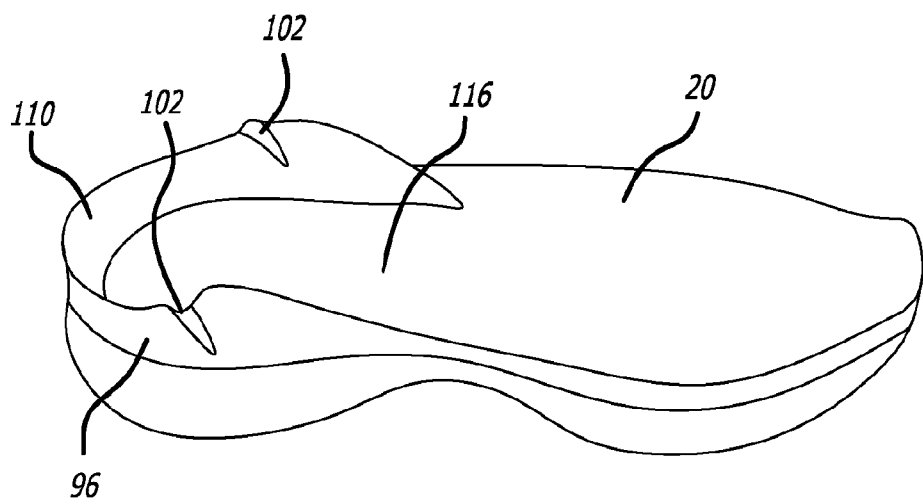

FIG. 22

FOOTWEAR COUNTER FOR EASIER ENTRY AND REMOVAL

CROSS REFERENCE TO RELATED APPLICATIONS

5 [001] The present disclosure claims the benefit of priority from U.S. Provisional Patent No. 63/256,521, which was filed on October 15, 2021.

TECHNICAL FIELD

10 [002] The present disclosure generally relates to a heel counter or a component of a heel counter of a shoe, and in particular a heel counter that is designed to allow for easier entry of the wearer's foot into the shoe.

BACKGROUND

15 [003] Conventionally, when donning footwear such as sports shoes, the user must often use one or both hands or operate a shoe horn separate from the shoe to properly insert the foot into the shoe and secure the quarter from collapsing under the heel.

BRIEF SUMMARY OF DISCLOSURE

[004] Aspects of this invention relate to an article of footwear that has a structure capable of distortion to support easier foot insertion.

20 [005] In one aspect of the invention, a heel cup may be uniformly molded with an upper portion, midportion, and lower portion, and the upper portion has a smaller mediolateral length than the midportion. The midportion and lower portion may form a concave structure configured to receive the heel. The upper portion of the heel cup has a first configuration in its native state and is capable of distorting into a second configuration under a load of a user's foot when the user is donning the footwear. In the second configuration, at least part of the upper portion is lowered relative to the first configuration and the upper portion is capable of returning to the first configuration after the load of the user's foot is removed. The midportion may include a peripheral portion having a first thickness and a central portion having a second thickness, and the second thickness is less than the first thickness.

30 [006] In another aspect of the invention, the upper portion of a heel cup has a first configuration in its native state and is capable of distorting into a second configuration under a load of a user's foot when the user is donning the footwear and the heel cup is capable of returning to the first configuration after the load of the user's foot is removed. In the first configuration, the upper

portion has a downward incline with a first angle relative to a vertical line that is normal to a horizontal surface of the floor, and the upper portion in the second configuration has an incline with a second angle greater than the first angle. Additionally, in the second configuration, a lower region of a central portion of the heel cup extends outward in a direction away from the shoe opening that causes the shoe opening to widen along the mediolateral direction.

5 **[007]** In another aspect of the invention, an upper of an article of footwear includes a U-shaped foamed ankle collar that is substantially tubular in shape and forms the topmost region of the foot receiving shoe opening. The foamed ankle collar may extend at least partially around and over the foot receiving shoe opening and may be compressed by the user's heel during foot insertion. The ankle collar may exert pressure on the user's ankle once the foot is inserted into the footwear. The ankle collar may also have a flattened region along its length forming a downward angle from the topmost region toward the front of the article of footwear.

10 **[008]** In another aspect of the invention, a heel counter support is located on the upper and above the sole structure. The heel counter support may have at least two hollow receptacles with backward angles. Additionally, each one of the two hollow receptacles receive one end of a compressible component. The compressible component has a first configuration in its native state, and the compressible component is capable of distorting into a second configuration under a load of a user's foot when the user is donning the footwear and is capable of automatically returning to the first configuration after the user's foot is fully inserted into the footwear.

20 **BRIEF DESCRIPTION OF THE DRAWINGS**

[009] By way of example only, selected embodiments and aspects of the present invention are described below. Each description refers to a figure ("FIG.") which shows the described matter. Some figures shown in drawings or photographs that accompany this specification may be for footwear that is for either the left or right foot. Each figure includes one or more identifiers for one or more part(s) or element(s) of the invention.

[0010] Various embodiments are described with reference to the drawings, in which:

[0011] FIG. 1 is a front view of a compressible heel cup.

[0012] FIG. 2 is a perspective view of the compressible heel cup of FIG. 1.

30 **[0013]** FIG. 3 is a side view of the compressible heel cup of FIG. 1.

[0014] FIGS. 4A and 4B are a side-by-side front perspective view of the compressible heel cup of FIG. 1 in its compressed configuration (4A) and its uncompressed configuration (4B).

- [0015]** FIGS. 4C and 4D are a side-by-side top view of the compressible heel cup of Fig. 1 placed within a shoe in its compressed configuration (4C) and its uncompressed configuration (4D).
- [0016]** FIG. 5 is a front view of a heel cup configured to have a series of crisscross beams.
- 5 **[0017]** FIG. 6A is a schematic illustration of a cross-section of arc lengths of the rearmost portion of the heel cup of FIG. 1.
- [0018]** FIG. 6B is cross-sectional view of the heel cup of FIG. 1 taken at lines 6-6 in FIG. 1.
- [0019]** FIG. 7 is a side view of a heel counter with a heel cup located in the interior of the heel counter.
- 10 **[0020]** FIG. 8 is a top view of the heel counter of FIG. 7.
- [0021]** FIG. 9 is a perspective view of the heel counter of FIG. 7.
- [0022]** FIG. 10 is a cross-sectional view of the heel counter of FIG. 8 taken at lines 10-10 in FIG. 8.
- [0023]** FIG. 11 is a perspective view of a shoe with a heel counter incorporating a rigid heel cup.
- 15 **[0024]** FIG. 12 is a side view of the shoe of FIG. 11.
- [0025]** FIG. 13 is a rear view of the shoe of FIG. 11.
- [0026]** FIG. 14 is a bottom view of a tongue and an instep support.
- [0027]** FIG. 15 is a perspective view of a shoe with a cushioned lining.
- [0028]** FIG. 16 is a side view of the cushioned lining of FIG. 15.
- 20 **[0029]** FIG. 17 is a perspective view of the cushioned lining of FIG. 15.
- [0030]** FIG. 18 is a top view of the cushioned lining of FIG. 15.
- [0031]** FIG. 19 is a cross-sectional view of the cushioned lining of FIG. 18 taken at lines 19-19 in FIG. 18.
- [0032]** FIG. 20A is a lateral view of a shoe with a heel counter support.
- 25 **[0033]** FIG. 20B is a perspective view of a shoe with a heel counter support.
- [0034]** FIG. 20C is a rear view of the shoe of FIG. 20A.
- [0035]** FIG. 21 is a perspective view of the bottom of the upper of the shoe of FIG. 20.
- [0036]** FIG. 22 is a perspective view of the sole and heel counter support of the shoe of FIG. 23.

30 **DETAILED DESCRIPTION**

[0037] A shoe may comprise a sole and an upper. The sole may comprise an outsole, a midsole, and/or an integrally formed outsole and midsole. The upper may comprise a toe box, a vamp, a tongue, a medial quarter, a lateral quarter, and a heel counter. The shoe has a forefoot portion, a rear portion, a medial side and a lateral side. The upper may comprise an exterior layer, interior

layers or interior structure, and/or an inner lining. The upper may form a shoe opening that is capable of receiving a user's foot when the user is donning the shoe.

[0038] The heel counter or rear portion of the upper may comprise a structure(s) that enables easier insertion of the foot into the shoe opening. The structure(s) may also support easier removal of the foot. The heel counter or rear portion of the upper may further have a transient widening when the user is donning or removing the shoe. The widening of the shoe opening may be initiated by the user placing a load on the heel counter or rear portion of the upper that may be exerted by the user's foot with minimal to no assistance by the user's hands. In other embodiments of the invention, the heel counter may be compressible when placed under sufficient load and return to its uncompressed stated. The lowering of the heel counter may also allow easier insertion of the user's foot. Once a foot is inserted into the shoe, the heel counter may have a compressible layer, such as a foam component, that secures or enhances securement of the foot during user's normal wear of the shoe.

[0039] Compressible Heel Cup. Referring to the embodiments of FIGS. 1-10 a heel counter 32 may comprise a compressible heel cup 52 which may be an interior component of the upper 16, a portion of the inner lining 46 or an attachment adjacent to the inner lining 46 of the upper 16 such that the heel cup 52 makes contact with the foot, or a portion of the exterior layer 42 of the upper 16 or an attachment of an outer surface of the exterior layer 42 of the upper 16.

[0040] Referring to the exemplary embodiment of FIGS. 1-4, the heel cup 52 has a shape substantially corresponding to a heel covering and having a profile resembling a pear-like shape. The heel cup has a mediolateral width near the heel cup collar 84 that is less than the mediolateral width of the lower portion 54 as shown in FIGS. 1-2

[0041] As shown in FIG. 2, the inner wall 66 of the upper portion 64 of the heel cup at the rearmost portion of the heel cup may have a downward incline of between 0 to 90 degrees relative to a vertical line 86 that is normal to the horizontal surface 88 of the floor. In this exemplary embodiment, the upper portion 66 may have a downward incline of 30 degrees. The inner wall 66 of the upper portion 64 of the heel cup 52 may also have a convex curvature facing toward the shoe opening 48. The top portion of the convex curvature has the downward incline A1 of 30 degrees. The lower portion of the convex curvature extends just above the portion of the heel cup 52 that receives the heel. The lower portion of the convex curvature may have a downward incline less than the downward incline of A1 and gradually decreases as it approaches an incline equal to the vertical line 86. The heel cup 52 has a concave curvature that surrounds the rear portion of the heel. The medial and lateral sides of the heel cup 52 may also extend and form support of part of the quarter and even as far as the vamp.

[0042] The thickness of the heel cup 52 may be reduced at various locations. The top edge line 88 may have a tapering of the inner surface of the heel cup 52 and outer surface of the heel cup 52. The heel cup 52 may have increased thickness T1 along the other perimeter edges, such as 2 to 3 mm. In another exemplary embodiment, the thickness T1 may be reduced in certain areas to provide greater flexibility to the heel cup 52 when donning or removing the shoe 12. In one embodiment, the thickness T1 of the heel cup 52 may decrease gradually from a peripheral portion 70 forming an area at the periphery of the heel cup 52 toward the central portion or region 50 of the mid-portion 58. The minimum thickness T1 in the central region 50 of the mid-portion 58 may be approximately, but not limited to 1/4 to 1/6 the thickness relative to the thickest portions at the periphery of heel cup 52, such as 0.5 to 1 mm. The thickest region of the top portion may be greater than the thickest region of the bottom portion. The reduced thickness T1 of the central region of the mid-portion 58 may allow for the heel cup 52 to compress under sufficient load. In an alternate embodiment, the thickness T1 may be reduced across the entire mediolateral portion or in multiple regions such as regions in the mid-portion 58 and/or regions of the upper portion 64. The thinner regions may provide increased flexibility and bending of the heel cup 52 which provides the necessary compressibility under the load of a user's foot such as during the donning of a shoe 12. Such compression may allow the upper portion 64 and/or the mid-portion 58 of the heel cup 52 to move rearward and widen the shoe opening 48 to allow easier entry of the foot. The heel cup 52 is capable of distortion from a first configuration in its native state, to a second configuration under a load of a user's foot when the user is donning the footwear. For example, the heel cup 52 may be partially compressed such that the upper portion 64 and/or mid-portion 58 of the heel cup 52 is lowered sufficiently to allow the insertion of the user's foot. See for example FIG. 9. Once the user's foot is inserted into the shoe 12, the heel cup 52 may return to its uncompressed configuration.

[0043] Further to this embodiment, when a user dons the shoe 12, the top portion of the convex curvature of the heel cup 52 or the uppermost segment of the heel counter 32 of the shoe 12 may be lowered and extend backward away from the foot as the heel counter 32 is compressed as shown in FIG. 4A. This action allows the user's foot to be inserted into the shoe opening 48 with a reduced degree of plantar flexion. During compression of the heel cup 52, portions of the heel cup 52 may move forward toward the direction of the forefoot portion. The distortion of the heel cup 52 may include the attached heel counter 32 widening with the medial and lateral sides of the heel cup moving outward thereby widening the opening of the shoe. The mediolateral widening of the shoe opening 48 allows easier entry such as easier insertion of the forefoot portion of the user's foot. In one exemplary embodiment, the shoe opening of 7.5 cm may widen up to 4 cm or about

50%. See FIGS. 4C and 4D. The widening may be less or more depending on the size of the shoe and the flexibility of the heel cup. In some shoes, the desired widening may be less or greater depending on the needs of securement and use.

[0044] In an exemplary embodiment of the heel cup 52 as shown in FIGS. 1-4, the thickness T1 of a heel cup 52 made of a polymer material, such as Dupont Hytrel, may range from 0.4 millimeters to 4 millimeters. The range of thickness T1 of the heel cup may be thinner or thicker at various regions depending on the desired elastic and durable properties of the material. For example, the midpoint region may be thinner than the surrounding regions, and in particular a central portion may be thinner as shown in FIG 6B. The central portion may be spaced away from the medial and lateral edges wherein the peripheral edges may have a greater thickness. Other suitable materials may include other thermoplastic elastomers or other polymers capable of providing the compressible characteristics of the heel cup.

[0045] In another exemplary embodiment, the heel cup may be configured to have a series of crisscross beams that form an egg crate like configuration. FIG. 5 shows an exemplary embodiment with beams that are in a diagonal configuration. In an alternate embodiment, the beams may also be in a vertical and lateral configuration. The apertures between the beams may be approximately uniformly sized. The beams may be uniform in dimensions or vary in thickness and width. Beams that are thinner or less wide may be used to enhance flexibility and compressibility in designated locations while thicker or wider beams provide varying degrees of rigid support. For example, the beams may be thinner in the mid-portion, and in particular, the central portion of the mid-portion that is spaced away from the edges. The surrounding beams may be thicker than the central portion. The central portion may allow for greater flexibility in order to distort under a load.

[0046] In an exemplary embodiment, the rearmost portion of the heel cup 52 may have an overall vertical cross-sectional shape that resembles approximately an S wave as shown on a cross-sectional diagram of FIG. 6A. The upper and lower portions of the S wave may be differentiated at the point P1 through a horizontal plane, i.e. the midline 90, which is drawn between the upper arc and lower arc ends of the S wave and intersects the heel counter 52 and the inflection point of the S wave. The amplitude (A_U) and width (W_U) of arc of the upper portion of the S wave may be different than the amplitude (A_L) and width (W_L) of the lower arc of the lower portion of the S wave. In the exemplary embodiment, the W_U is approximately 0.44 times that of the W_L . The A_U is approximately 1/3 that of the A_L . In one possible embodiment, the W_U is approximately 2 centimeters and the W_L is approximately 4.5 centimeters. The A_U is roughly 3 millimeters and the A_L is roughly 9 millimeters. The S configuration decreases both in A_U/A_L and W_U/W_L in the cross-

sections in the areas extending from the rearmost portion's cross-section of the heel cup 52 and may only consist of the lower portion arc along the medial and lateral sides of the heel cup 52. The measurements at the rearmost portion of the heel cup 52 of the exemplary embodiment are intended to be exemplary.

5 **[0047]** The central region of the mid-portion of the heel cup may have a single aperture or a plurality of apertures. Just as the central region of the mid-portion may be constructed with less material than the maximum thickness of the collar and/or the maximum thickness of the base, the central region of the mid-portion of the heel cup may be constructed with a material of greater flexibility than the material forming its periphery. The resulting effects of the central region
10 comprising a single aperture, a plurality of apertures, a lesser thickness, and/or a material of greater flexibility, may serve to facilitate entry and removal of the user's foot from the shoe.

[0048] Further to the exemplary embodiment, the heel cup 52 may be attached at least to an interior foam layer 92, as shown in FIG. 10. The heel cup 52 may be located in the interior of the heel counter 32 of the upper 16 as shown in FIGS. 8-10. The foam layer 92 may line both the
15 inner wall 66 of the heel cup 52 and outer wall of the heel cup 52. Around the upper portion and mid-portion, the foam layer 92 may protrude and extend further into the shoe opening 48. The foam layer 92 may be thicker at or adjacent to the upper portion 64 and mid-portion 58 of the heel cup 52 thereby forming part of the cuff of the shoe opening 48. The thicker foam layer 92 may provide securement of the user's foot once inserted within the shoe 12 as the foam would be located
20 above the calcaneus bone region of the user's foot and extend around at least portions of the ankle region of the foot. Since the foam is compressible, the foam may be compressed by the heel during foot insertion or removal and hold the ankle of the user's foot once the foot is inserted.

[0049] Rigid Heel Cup. In one exemplary embodiment, a shoe 12 may have a heel counter 32 located at the rear portion 36 of a shoe upper 16 as shown in FIGS. 11-13. The heel counter 32
25 may comprise a heel cup 52 which may be an interior component of the upper 16, a portion of the inner lining 46 or an attachment adjacent to the inner lining 46 of the upper 16 such that the heel cup 52 contacts the foot, or a portion of the exterior layer 42 of the upper 16 or an attachment of an outer surface of the exterior layer 42 of the upper 16.

[0050] The heel cup may have a lower portion that forms a heel cup configured to receive the
30 heel of the foot. The lower portion of the heel cup may further have side extensions around both the medial side and lateral side. The heel cup may have a mid-portion located above the lower portion of the heel cup and that curves inward above the heel bone or may be composed of an aperture. The heel cup may have an aperture located at the rear of the heel cup. Further to this

embodiment, the heel cup may be a rigid heel cup constructed of a substantially incompressible material under the load of the foot.

5 **[0051]** At least one aperture may be incorporated into the mid-portion of the rigid heel cup that may be added to enhance the fit of the shoe around the foot of the heel. The upper material layers covering the aperture may comprise an elastic material such that the material stretches around the contours of the heel. The tension created by the elastic material upon stretching may enhance the securement of the foot during normal use of the shoe.

10 **[0052]** The upper portion of the heel cup may be configured with a smooth curvature extending from the top edge of the heel cup curved downward towards the shoe opening 48. The inner wall of the upper portion has an overall downward incline that extends from the curved top edge of the upper portion toward the interior of the upper 16. The inner wall of the upper portion may have dimensions akin to a shoehorn such that the smooth curvature and angle of the downward incline of the upper portion allows the heel of the foot to slide into the shoe 12 with greater ease. The heel cup may be constructed of a rigid material that does not substantially compress under the load
15 of the user's foot. In an alternate embodiment, the heel cup may have some flexibility such that the upper portion of the heel cup may have some slight flexibility sufficient to bend downward and away from the shoe opening and/or widen the shoe opening 48 for easier foot insertion and/or removal.

20 **[0053]** As shown in FIG. 11, the top edge 72 of the heel counter 32 may also form a resilient support structure of the rear heel collar 74. When the heel cup 52 is incorporated into the upper 16, a fabric material(s) or a suitable material(s) known in the art may be used to cover the heel cup 52 thereby forming the exterior layer 42 and interior layers or structures 44 of the upper. The fabric material may extend above the heel cup 52 thereby forming an extension of the heel collar 74.

25 **[0054]** Foam material or any inner lining material(s) known in the art may be used as an inner compressible layer of the upper 16 of FIG. 11. The foam material 76 may be bonded to the inner surface of the heel cup 52 to provide cushioning against the rigid heel cup material. The thickness of the foam material may be uniform or vary at certain locations depending on the desired cushioning or support to the foot. In one exemplary embodiment, thicker foam material may be
30 located at the inner wall 66 of the upper portion 64 and may further extend at least a portion along the mediolateral length of the inner wall 66. The foam material may be configured to curve around at least a portion of the ankle above the heel when the shoe 12 is worn similar to the foam material configuration shown in FIG. 10. In this embodiment, the user's foot may compress the foam material during foot insertion. Following foot insertion, the foam material may expand to its fully

uncompressed state or partially expand thereby improving the security of the foot within the shoe 12. A thinner foam material may be used to line the other portions of the heel cup 52.

5 **[0055]** The rigid heel cup 52 may be used in combination with a shoe upper 16 having at least one elastic region 78 located on the sides of the upper between the heel cup 52 and the front portion of the foot receiving shoe opening 48. The elastic region 78 may have one or more elastic materials that allow the rear portion of the heel counter 32 to be temporarily moved back to widen the foot receiving shoe opening 48 for easier insertion of the foot into the shoe 12. As shown in FIG. 11, the elastic material may be a gore piece 80 configured to be fixed within a void of the upper such as in the form of a gusset on the medial quarter or lateral quarter or both. The elastic material may be in any spacing between the heel cup 52 and the upper portion located at the quarters 30 or vamp 10 24 or possibly a tongue. The elastic material may also be configured as a series of elastic strips or webbing extending between the heel cup 52 to the medial and lateral sides of the vamp 24 or possibly a tongue.

15 **[0056] Instep Support.** In some embodiments, an instep support may be used to aid in preventing, in some instances, the instep of the user's foot from dragging a portion of the instep, or tongue partially into the throat area as the user dons the shoe.

20 **[0057]** In some embodiments having a tongue 126 as shown in FIG. 14, the medial side of the upper portion 132 of the tongue 126 is attached to the first or proximal end of a medial elastic strap 128 and the lateral side of the upper portion 132 of the tongue 126 is attached to the first or proximal end of a lateral elastic strap 130. The front lower portion of the tongue is attached directly to the upper. Each of the medial and lateral elastic straps may be attached to the upper directly to the inner lining of the upper at its second or distal ends. In an alternate embodiment, the elastic straps may extend through an opening of the inner lining of the medial quarter and lateral quarter respectively. The second end of each of the medial and lateral elastic straps may terminate 25 respectively at the sole, sockliner, or a region within the upper's interior lining. The elastic straps function to maintain the general positioning of the tongue when the user dons the shoe.

30 **[0058]** In other embodiments, each of the medial and lateral sides of the edge of the tongue or an upper portion of the tongue are attached by a gusset which may be of elastic material, to the inner lining of the upper of the medial quarter and lateral quarter of the upper. The gusset similarly may function to maintain the general positioning of the tongue when the user dons the shoe. In another embodiment of the tongue, the at least a portion of the medial and lateral edges of the tongue may be directly affixed or stitched to the interior portion of the upper and the tongue. Furthermore, the tongue may be extended wider than a conventional tongue along the mediolateral

direction in the upper portion of the tongue and the edges or some portion of the extended portion may be affixed or stitched to the interior portion of the upper.

[0059] In other embodiments, an instep or tongue support which may be constructed of a sheet-like material of greater hardness than the fabric of the instep or tongue may be attached to the outer surface of the tongue or embedded between an exterior tongue layer and an inner tongue layer facing the shoe opening. The instep or tongue support may reduce or prevent the instep or tongue from collapsing during the insertion of the foot. In one embodiment shown in FIG. 14, tongue support 134 may be a more rigid material such as a thermoplastic polymer configured to be more rigid than the tongue. In some embodiments, the instep or tongue support may have a thickness of 0.2 mm to 1 mm. The instep support may be coextensive with the instep or tongue, or it may extend beyond the medial or lateral sides of the instep or tongue. In the embodiment shown in FIG. 14, the tongue support 134 may be narrower and shorter than the instep or tongue.

[0060] In one embodiment, a reinforcing quarter element may extend from the heel counter to the instep or eyestay. When a gusset is incorporated such as gusset 80 in FIG. 11-12, a reinforcing quarter element may extend from the heel counter 52 along the front lower edge of the gusset and around the top edge of the collar to the instep, a region near vamp 24, or an eyestay adjacent to a tongue. A reinforcing quarter element may be stiffer than the upper or quarter material. The reinforcing quarter element material may be constructed of leather, plastic, or rigid fabric. The reinforcing quarter element may be attached to the upper through bonding or stitching. The reinforcing quarter element may be configured as an elongated shape such as a strip that extends along the front lower edge of the gusset and the collar portion. The reinforcing quarter element may be located on the exterior surface or may be an interior layer of the upper such as a layer embedded within the upper or along a portion of the inner lining of the upper. A reinforcing quarter element may provide greater stability to the opening of the shoe such that it provides resistance against the quarters and instep region collapsing or moving inward into the opening of the shoe when the foot is inserted into the shoe and pushes the heel cup rearward.

[0061] When the reinforcing quarter element is used in combination with an eyestay layer used in laced shoes, the eyestay may add additional structural support in providing resistance against the quarters and instep from collapsing or moving inward into the opening of the shoe. Thus, as a foot pushes against the heel cup and the gusset is stretched rearward, the reinforcing quarter element is not significantly pulled rearward. Accordingly, the shoe opening may attain a wider opening when the foot is inserted into the shoe and pushes the heel cup rearward.

[0062] Compressible lining. In some embodiments, the inner surface of the heel counter and heel/ankle collar may have a portion having a compressible layer such as a foam layer. The

compressible layer may extend into the shoe opening. The compressible layer is compressed under a load during the donning or removal of the shoe. After the foot is inserted into the shoe, the foam layer may expand fully or partially to its uncompressed state, and such expansion may enhance the securement of the foot within the shoe.

5 **[0063]** In one exemplary embodiment, the compressible layer 100 is embedded at least within a portion of the ankle collar 140 and the upper region of the heel counter 32. See FIGS. 15-19. The compressible layer 100 extends into the opening of the shoe. During the donning of the shoe, the foot exerts a load onto the compressible layer thereby widening the opening of the shoe through the transient compression of the compressible layer. After the foot is inserted into the shoe, the
10 compressible layer expands partially or fully back to its original shape. Expansion of the compressible layer causes the foam to expand around the foot which may enhance comfort and securement of the foot. In some embodiments, the compressible layer extends above and/or around the calcaneus bone of the user's foot and around at least portions of the ankle region of the foot.

[0064] The compressible layer may be constructed of a material of a foam material such as EVA
15 or polyurethane foam. The shape of the compressible layer may be pre-formed by molding the material, and affixing the compressible layer between at least two layers of textile material. The shape of the compressible layer may have at least partially a rounded outer surface that extends into the opening of the shoe and/or the ankle collar of the shoe. The volume of the compressible layer may be greater in the rear portion of the heel counter and taper along longitudinal direction
20 of the inner portion of the foam layer at both sides of the shoe as shown in FIGS. 17-18. The compressible layer may also taper or be rounded along the vertical axis and that the compressible layer is greater in volume at the upper portion of the ankle collar 140 and less at the lower portion of the ankle collar 140. See FIGS. 18-19. The compressible layer may be used to form the entire heel cup without the need of an additional heel cup or heel counter. Alternatively, the compressible
25 layer can be used in combination with a compressible heel cup, such as shown in FIG. 1. The heel cup can define an exterior surface of the upper, the heel cup can define an interior surface of the upper, or the heel cup can define an internal layer, for example, if embedded within the compressible layer.

[0065] In the exemplary embodiment, a lower flange 118 may extend downward from the ankle
30 collar and is configured to attach to the upper. The lower flange may be configured in any dimensions necessary to secure the ankle collar to the upper. The lower flange may also vary in the length. In some embodiments, the lower flange may define the portion of the ankle collar attached to the upper without extending downward from the ankle collar at all. In other embodiments, the lower flange may extend downward partially or fully to the bottom of the upper.

In some embodiments, the lower flange may be configured to form the heel counter. In other embodiments, a heel cup, such as shown in FIG. 1, may be partially or fully embedded in lower flange.

5 **[0066]** The compressible layer 100 may be covered by any type of textile. The textile may be elastic and may have wicking properties. The textile may be form fitted to the exterior shape of the compressible layer. In a preferred embodiment, an adhesive such as a thermoplastic based adhesive is applied to the compressible layer after which the compressible layer is inserted into an elastic textile sleeve. The resulting product may also be affixed by any means such as glue or stitching according to the desired pattern of the ankle collar 140. The textile may also include
10 thermoplastic material and after the compressible layer 100 is inserted into the textile sleeve, heat may be applied to fuse the textile to the compressible layer 100. In a preferred embodiment, steam may be applied so that the textile conforms to the preformed shape that forms a portion of the ankle collar and/or heel counter.

[0067] Further to the exemplary embodiment, the ankle collar 140 is devoid of stitches or seams
15 on its upper portion and may have a seam on the bottom portion where it is attached to the upper 16. The seamless ankle collar 140 may extend from the medial quarter, around the heel, to the lateral quarter. As the user's foot is inserted into the footwear, the user's heel depresses the compressible layer 100 against the heel cup. The heel cup may keep the structural integrity of a portion of the heel region of the upper 16 from collapsing when the user's heel depresses the
20 compressible layer 100, thus allowing for an easier entry into the shoe by the user's foot without the use the user's hands or an external shoe horn. Once the user's heel is fully inserted into the shoe, the compressible layer may rebound and may exert force against the back of the user's heel above the calcaneus bone and around portions of the ankle region which may aid in providing comfort and securing the user's foot within the shoe.

25 **[0068]** Further to the exemplary embodiment, the cross-section of the seamless upper portion of the ankle collar 140 is substantially round. The ankle collar 140 may be separated into a forward portion 142 and a rear portion 144. Each of the forward portion and rear portion resemble an approximately circular cross-section 22 or semicircular cross-section wherein the radius of the forward portion is greater than the radius of the rear portion. See FIGS. 18-19. The compressible
30 layer may be directly attached to the inner structure of the heel counter or via the textile sleeve covering the compressible layer material.

[0069] Compressible Heel Counter with Heel Counter Support. In another exemplary embodiment, heel counter support 96 may partially form an exterior layer of the shoe and extend around the heel portion of the upper 16 from the medial quarter of the shoe to the lateral quarter

of the shoe as shown in FIGS. 20-22. In other embodiments, the heel counter support may further extend along a portion of the quarter, along the entire quarter, or along the entire quarter and into the vamp portion of the shoe. The heel counter support 96 may vary in height at different regions of the shoe. In the exemplary embodiment, the medial end and lateral end of the heel counter support 96 gradually decreases in height to the base of the upper 16 just above the sole 14. The heel counter supports 96 may have a medial region of a maximum height on the medial side of the heel portion of the upper, and a maximum height on the lateral side on the heel portion of the upper. The heel counter support 96 extends at least a portion of the height of the upper 16. In the exemplary embodiment, the height of the medial and lateral side heel portions 98 of the upper 16 is roughly 5 cm above the lasting surface 116 and the maximum height of the heel counter support 96 on the medial and lateral sides of the heel portion is roughly 3 centimeters above the lasting surface 116. The heel counter support 96 may gradually reduce in height from the region of its maximum height to a region of roughly uniform height along the rear of the heel portion 98 of the upper 16. In the exemplary embodiment, the height along the heel portion 98 of the upper 16 extends up to roughly 3 centimeters above the lasting surface 116, and the roughly uniform height of the portion forming rear portion of the heel counter support 96 is roughly 2 centimeters above the lasting surface 116.

[0070] The heel counter support 96 may partially form an exterior surface of the upper 16. The heel counter support 96 may have an interior surface in contact with an outer surface of the heel portion 98 of the upper 16. The heel counter support 96 may have a varying thickness across its exterior surface to its interior surface. In the exemplary embodiment, angular strips 102 form portions of increased thickness of the heel counter support 96. The angular strips 102 may provide increased rigidity to the heel counter support 96 as well as be configured to receive the compressible component 100.

[0071] In the exemplary embodiments, the angular strips 102 have hollowed protrusions on the medial and lateral sides of the shoe 12 into which the ends of the compressible component 100 are secured. The compressible component 100 may be a pipe wherein each end of the pipe is secured within the hollowed protrusions 102. A hollowed protrusion of the angular strips 102 may extend partially or completely around the surfaces of the compressible component 100. In the exemplary embodiment, the compressible component 100 may be formed from polyoxymethylene or any other material with similar durability and sufficient rigidity to support the load of a foot and flexibility to curve from medial to lateral sides of the heel portion of the shoe 12. The central segment 104 of the compressible component 100 may extend behind the ankle opening and above the heel counter of the shoe 12. In the exemplary embodiment, the angular strips 102 may be

designed to receive the compressible component 100 at an angle so that the compressible component 100 extends from inside the hollowed protrusions 102 at a rearward incline A2 toward the back of the shoe 12. The rearward incline A2 of the compressible component 100 is approximately 45 degrees with respect to a level plane of the floor 88. See Fig. 20A. A foam layer 92 extending above the rear heel portion 98 of the upper 16 at the rear portion of the heel opening may have a rearward incline A2 that is coextensive with the compressible component 100. The rearward incline A2 of the foam layer 92 may assist in guiding the user's foot into the shoe 12 when donning the shoe.

[0072] The central segment 104 of the compressible component 100 may extend behind the rearmost portion of the upper 16 and may be threaded through one or more guide tunnels 106 in the upper 16. In the exemplary embodiment, strips of leather material are sewed to the foam layer 92 and extend above the upper at the rear portion of the heel opening. The ends of the strip of leather are stitched together to form guide tunnels 106 through which the compressible component is threaded.

[0073] When donning the shoe 12, the user's foot may depress the compressible component 100 and/or the rearwardly inclined foam layer 92 downward and rearward from the shoe opening. Once the user's foot has fully entered the shoe 12, the compressible component 100 and the rearwardly inclined foam layer 92 return to their initial elevated positions.

[0074] The additional interior heel support 114 made of foam material may have sufficient thickness that may enhance securing the foot at the Achilles tendon, and once the user dons the shoe 12, the calcaneus bone may be located below the additional interior heel support 114. The interior heel support 114 may have a sufficient height to be located above the calcaneus bone once the foot has been inserted into the shoe.

[0075] Further to the exemplary embodiment, the shoe may have a heel cup 52 made of a flexible material configured to receive the rear portion of the heel. In one embodiment, the heel cup is a thermoplastic material that provides sufficient support as a heel counter. The interior heel support 114 may be foam material lining to provide the necessary comfort to the user's heel.

[0076] Although the present invention has been described above by referring to particular embodiments, it should be understood that modifications and variations could be made to the sole structure without departing from the intended scope of invention.

Consistory Set of Clauses

1. An article of footwear comprising:
 - an upper and sole structure;
 - 5 the upper defining a foot receiving shoe opening;
 - a heel cup attached to the upper and extending from the sole structure to at least a portion of the rear heel collar of upper;
 - the heel cup uniformly molded with an upper portion, midportion, and lower portion where in the upper portion has a smaller mediolateral length than
 - 10 the midportion, and the midportion and lower portion form a concave structure configured to receive the heel;
 - the upper portion having a first configuration;
 - the upper portion capable of distorting into a second configuration
 - under a load of a user's foot when the user is donning the footwear;
 - 15 wherein in the second configuration at least part of the upper portion is lowered relative to the first configuration;
 - the upper portion capable of returning to the first configuration after the load of user's foot is removed;
 - the midportion defining a peripheral portion and a central portion;
 - 20 the peripheral portion having a first thickness; and
 - the central portion having a second thickness;
 - the second thickness being less than the first thickness.
2. The article of footwear of clause 1 wherein the first thickness decreases gradually to the second thickness in a direction extending from the peripheral portion to the central
- 25 portion.
3. The article of footwear of clause 1 wherein at least a portion of the upper portion and a portion of the lower portion have a thickness approximately equal to or greater than the first thickness.
4. The article of footwear of clause 1 wherein a lower region of the central portion extends
- 30 outward in a direction away from the shoe opening that causes the shoe opening to widen along the mediolateral direction.
5. The article of footwear of clause 1 wherein the upper portion in the first configuration has a downward incline with a first angle relative to a vertical line that is normal to a

horizontal surface of the floor and the upper portion in the second configuration has an incline with a second angle, and the second angle is greater than the first angle.

6. The article of footwear of clause 1 wherein in the second configuration, an upper region of the central portion of the midportion is closer to the front of the article of footwear than in the first configuration.
7. The article of footwear of clause 1 wherein in the second configuration, the peripheral portion of the midportion is extended outward along the mediolateral width of the article of footwear to a greater extent than in the first configuration.
8. The article of footwear of clause 1 wherein the second thickness is at least $1/6$ of the first thickness.
9. The article of footwear of clause 1 wherein the first thickness is no greater than 3.07 mm and the second thickness is at least 0.5 mm.
10. The article of footwear of clause 1 wherein an elastic member is located between the heel cup and a front portion of the foot receiving shoe opening.
11. The article of footwear of clause 1, further comprising a tongue wherein a support member is attached to the tongue and the support member prevents deformation of the tongue when the user is donning the footwear.
12. The article of footwear of clause 11 wherein the support member is a connector that connects a portion of the tongue to the upper.
13. The article of footwear of clause 11, wherein the support member is a rigid member that is at least partially coextensive with the tongue.
14. The article of footwear of clause 1, wherein a foam component is located on at least an inner surface of the upper portion and midportion of the heel cup; the foam component is compressed by the user's heel during foot insertion; and the foam component may exert pressure on the user's ankle once the foot is inserted.
15. The article of footwear of clause 14 wherein the foam component extends from both sides of the upper portion of the heel cup along at least a portion of the inner surface of the upper to form side sections of the foam component.
16. The article of footwear of clause 15 wherein the foam component tapers at the side portions.
17. The article of footwear of clause 16 wherein the rear portion of the foam component curves inward and tapers vertically downward along a concave structure of the heel cup.
18. An article of footwear comprising:
 - an upper and sole structure;

the upper defining a foot receiving shoe opening;

a heel cup attached to the upper and extending from the sole structure to at least a portion of the rear heel collar of upper;

the heel cup uniformly molded with an upper portion, midportion, and lower portion where in the upper portion has a smaller mediolateral length than the midportion, and the midportion and lower portion form a concave structure configured to cup the heel; the upper portion having a first configuration;

the upper portion capable of distorting into a second configuration under a load of a user's foot when the user is donning the footwear;

the upper portion capable of returning to the first configuration after the load of the user's foot is removed; and wherein

the upper portion in the first configuration has a downward incline with a first angle relative to a vertical line that is normal to a horizontal surface of the floor;

the upper portion in the second configuration has an incline with a second angle;

and the second angle is greater than the first angle; and

a lower region of the central portion extends outwardly in a direction away from the shoe opening that causes the shoe opening to widen along the mediolateral direction.

19. The article of footwear of clause 18 wherein the midportion defines a peripheral portion and a central portion, the peripheral portion having a first thickness and the central portion having a second thickness; the second thickness being less than the first thickness of the heel cup.

20. An upper of an article of footwear comprising:

a foot receiving shoe opening;

a U-shaped foamed ankle collar that is substantially tubular in shape;

the ankle collar forming the topmost region of the foot receiving shoe opening; the foamed ankle collar extending at least partially around and over the foot receiving shoe opening;

the ankle collar capable of being compressed by the user's heel during foot insertion and wherein the ankle collar may exert pressure on the user's ankle once the foot is inserted; and

the ankle collar having a flattened region along its length forming a downward angle from the topmost region toward the front of the article of footwear.

21. The upper of clause 20, wherein the lower portion of the ankle collar has an attachment piece affixed to the upper.
22. The upper of clause 20, wherein the ankle collar is devoid of stitches or seams on an upper portion of the ankle collar.
- 5 23. The upper of clause 20, wherein the cross-sectional shape of the ankle collar has a first portion and a second portion; the first portion being approximately a semicircle with a first radius; the second portion being approximately a semicircle with a second radius; and wherein the first radius is greater than the second radius.
24. The upper of clause 20, further comprising a heel cup; the heel cup having a first configuration; the heel cup capable of distorting into a second configuration under a load of a user's foot when the user is donning the footwear; the heel cup capable of automatically returning to the first configuration after the user's foot is fully inserted into the footwear; and the ankle collar is located above the heel cup.
- 10 25. An upper of an article of footwear comprising:
- 15 a foot receiving shoe opening;
- a U-shaped foamed ankle collar that is substantially tubular in shape;
- the ankle collar forming the topmost region of the foot receiving shoe opening; the foamed ankle collar extending at least partially around and over the foot receiving shoe opening; and
- 20 the ankle collar capable of being compressed by the user's heel during foot insertion and wherein the ankle collar may exert pressure on the user's ankle once the foot is inserted;
- the ankle collar having a flattened region along its length forming a downward angle from the topmost region toward the front of the article of footwear.
- 25 26. The upper of clause 25, wherein the lower portion of the ankle collar has an attachment piece affixed to the upper.
27. The upper of clause 25, wherein the ankle collar is devoid of stitches or seams on an upper portion of the ankle collar.
28. The upper of clause 25, wherein the cross-sectional shape of the ankle collar has a first portion and a second portion; the first portion being approximately a semicircle with a first radius; the second portion being approximately a semicircle with a second radius; and wherein the first radius is greater than the second radius.
- 30 29. The upper of clause 25, further comprising a heel cup; the heel cup having a first configuration; the heel cup capable of distorting into a second configuration under a load

of a user's foot when the user is donning the footwear; the heel cup capable of automatically returning to the first configuration after the user's foot is fully inserted into the footwear; and the ankle collar is located above the heel cup.

- 5 30. The upper of clause 25, wherein the heel cup defines a peripheral portion and a central portion; the peripheral portion having a first thickness; the first thickness defining the maximum thickness of the heel cup; the central portion having a second thickness; the second thickness defining the minimum thickness of the heel cup; and the first thickness decreasing gradually to the second thickness in a direction extending from the peripheral portion to the central portion.
- 10 31. An article of footwear comprising:
an upper and sole structure
the upper defining a foot receiving shoe opening;
a heel counter support situated on the upper and above the sole structure;
the heel counter support having at least two hollow receptacles with
15 backward angles;
a compressible component having two ends;
each one of the two hollow receptacles receiving one end of the compressible component;
the compressible component having a first configuration;
20 the compressible component capable of distorting into a second configuration under a load of a user's foot when the user is donning the footwear; and
the compressible component being capable of automatically returning to the first configuration after the user's foot is fully inserted into the footwear.
- 25 32. The article of footwear of clause 31, wherein the heel counter support defines an exterior layer of the upper.
33. The article of footwear of clause 31, wherein the compressible component is cylindrical.
34. The article of footwear of clause 31, wherein the compressible component extends from the medial quarter, above the foot receiving shoe opening, to the lateral quarter.
- 30 35. The article of footwear of clause 31, wherein the compressible component extends through a tunnel attached to the upper.

CLAIMS

1. Shoe comprising a heel counter;
the heel counter comprising a heel cup;
5 the heel cup being molded with an upper portion, a midportion, and a lower portion;
wherein the upper portion has a smaller mediolateral length than the midportion;
wherein in a vertical cross-section, the heel cup has an S wave shape;
wherein in the vertical cross-section, the upper portion has a first thickness in a first location;
wherein in the vertical cross-section, the midportion has a second thickness in a second location;
10 wherein in the vertical cross-section, the lower portion has a third thickness in a third location;
wherein the second thickness is smaller than at least one of the first thickness and the third
thickness; and
wherein the midportion provides flexibility of the heel cup.
- 15 2. Shoe according to claim 1, wherein the heel cup is a compressible heel cup.
3. Shoe according to claim 1 or 2, wherein the heel cup is uniformly molded with the upper
portion, the midportion, and the lower portion.
- 20 4. Shoe according to any one of the preceding claims, wherein the thickness of the heel cup
decreases gradually from the first location to the second location.
5. Shoe according to any one of the preceding claims, wherein the thickness of the heel cup
decreases gradually from the third location to the second location.
- 25 6. Shoe according to any one of the preceding claims, wherein the upper portion of the heel cup
has a first configuration and is configured to be distorted into a second configuration under a
load of a user's foot, when the user is donning the shoe, wherein in the second configuration, at
least part of the upper portion is lowered relative to the first configuration and the upper portion
30 is configured to return to the first configuration after the load of the user's foot is removed.
7. Shoe according to claim 6, wherein the distortion of the heel cup into the second configuration
comprises the heel counter widening with medial and lateral sides of the heel cup moving
outward thereby widening an opening of the shoe.

8. Shoe according to any one of the preceding claims, wherein the midportion and the lower portion form a concave structure configured to receive a heel.
- 5 9. Shoe according to any one of the preceding claims, wherein an inner wall of the upper portion of the heel cup comprises a convex curvature facing toward a shoe opening.
10. Shoe according to any one of the preceding claims, wherein the heel cup is attached at least to an interior foam layer.
- 10 11. Shoe according to claim 10, wherein the interior foam layer protrudes and extends into the shoe opening around the upper portion and midportion of the heel cup.
12. Shoe according to claim 10 or 11, wherein the interior foam layer forms part of a cuff of the shoe opening.
- 15 13. Shoe according to any one of the preceding claims, wherein the vertical cross-section is the vertical cross-section of a rearmost portion of the heel cup.
- 20 14. Shoe according to any one of the preceding claims, wherein the first location is a location of the upper portion; and/or wherein the second location is a location of the midportion; and/or wherein the third location is a location of the lower portion.
- 25 15. Shoe according to any one of the preceding claims, wherein the first location is the location of the upper portion having the biggest thickness in the vertical cross-section of the upper portion; and/or wherein the second location is the location of the midportion having the smallest thickness in the vertical cross-section of the midportion; and/or
- 30 wherein the third location is the location of the lower portion having the biggest thickness in the vertical cross-section of the lower portion.
16. Shoe according to any one of the preceding claims, wherein the second location is a location of an inflection point of the S wave.

17. Shoe according to any one of the preceding claims, wherein the midportion in addition provides bending of the heel cup.

Amendments to the claims have been filed as follows:

CLAIMS

1. Shoe comprising a heel counter;
the heel counter comprising a heel cup;
5 the heel cup being molded with an upper portion, a midportion, and a lower portion;
wherein the upper portion has a smaller mediolateral length than the midportion;
wherein the rearmost portion of the heel cup has an overall vertical S wave cross-sectional shape;
wherein in the vertical cross-section, the upper portion has a first thickness in a first location;
wherein in the vertical cross-section, the midportion has a second thickness in a second location;
10 wherein in the vertical cross-section, the lower portion has a third thickness in a third location;
wherein the second thickness is smaller than: the first thickness, and the third thickness, such that
the variation in the thickness of the heel cup provides flexibility of the heel cup.
2. Shoe according to claim 1, wherein the heel cup is a compressible heel cup.
- 15 3. Shoe according to claim 1 or 2, wherein the heel cup is uniformly molded with the upper
portion, the midportion, and the lower portion.
4. Shoe according to any one of the preceding claims, wherein the thickness of the heel cup
20 decreases gradually from the first location to the second location.
5. Shoe according to any one of the preceding claims, wherein the thickness of the heel cup
decreases gradually from the third location to the second location.
- 25 6. Shoe according to any one of the preceding claims, wherein the upper portion of the heel cup
has a first configuration and is configured to be distorted into a second configuration under a
load of a user's foot, when the user is donning the shoe, wherein in the second configuration, at
least part of the upper portion is lowered relative to the first configuration and the upper portion
is configured to return to the first configuration after the load of the user's foot is removed.
- 30 7. Shoe according to claim 6, wherein the distortion of the heel cup into the second configuration
comprises the heel counter widening with medial and lateral sides of the heel cup moving
outward thereby widening an opening of the shoe.

20 08 24

8. Shoe according to any one of the preceding claims, wherein the midportion and the lower portion form a concave structure configured to receive a heel.

5 9. Shoe according to any one of the preceding claims, wherein an inner wall of the upper portion of the heel cup comprises a convex curvature facing toward a shoe opening.

10. Shoe according to any one of the preceding claims, wherein the heel cup is attached at least to an interior foam layer.

10 11. Shoe according to claim 10, wherein the interior foam layer protrudes and extends into the shoe opening around the upper portion and midportion of the heel cup.

12. Shoe according to claim 10 or 11, wherein the interior foam layer forms part of a cuff of the shoe opening.

15 13. Shoe according to any one of the preceding claims, wherein the vertical cross-section is the vertical cross-section of a rearmost portion of the heel cup.

20 14. Shoe according to any one of the preceding claims, wherein the first location is a location of the upper portion; and/or wherein the second location is a location of the midportion; and/or wherein the third location is a location of the lower portion.

25 15. Shoe according to any one of the preceding claims, wherein the first location is the location of the upper portion having the biggest thickness in the vertical cross-section of the upper portion; and/or wherein the second location is the location of the midportion having the smallest thickness in the vertical cross-section of the midportion; and/or wherein the third location is the location of the lower portion having the biggest thickness in the
30 vertical cross-section of the lower portion.

16. Shoe according to any one of the preceding claims, wherein the second location is a location of an inflection point of the S wave.

20 08 24

17. Shoe according to any one of the preceding claims, wherein the midportion in addition provides bending of the heel cup.

20 08 24



Application No: GB2404132.9

Examiner: Carrie-Ann Williams

Claims searched: 1-17

Date of search: 29 April 2024

Patents Act 1977: Search Report under Section 17

Documents considered to be relevant:

Category	Relevant to claims	Identity of document and passage or figure of particular relevance
X	1-4,6,8,9,13-15,17	CN109393642 A (ZHUANG) see figures in particular
X	1-4,6-9,13-17	US6880272 A1 (WELLS) see figures and column 5 lines 34-44 in particular

Categories:

X	Document indicating lack of novelty or inventive step	A	Document indicating technological background and/or state of the art.
Y	Document indicating lack of inventive step if combined with one or more other documents of same category.	P	Document published on or after the declared priority date but before the filing date of this invention.
&	Member of the same patent family	E	Patent document published on or after, but with priority date earlier than, the filing date of this application.

Field of Search:

Search of GB, EP, WO & US patent documents classified in the following areas of the UKC^X :

Worldwide search of patent documents classified in the following areas of the IPC

A43B

The following online and other databases have been used in the preparation of this search report

SEARCH-PATENT

International Classification:

Subclass	Subgroup	Valid From
A43B	0023/17	01/01/2006
A43B	0011/02	01/01/2006
A43B	0021/32	01/01/2006
A43B	0023/08	01/01/2006