

(19)
(12)

(KR)
(B1)

(51) 。 Int. Cl. ⁶
H01L 21/70
H01L 21/334

(45)
(11)
(24)

2001 11 07
10 - 0313505
2001 10 22

(21) 10 - 1999 - 0005547
(22) 1999 02 19

(65) 2000 - 0056331
(43) 2000 09 15

(73)

1

(72)

1 L G B 237

(74)

:

(54)

, ' 가 .
, ; ; ;
, ; , 가 .

2g

1a 1d

2a 2g

1: 2:

3: 4:

5: 6:

7: 8:

9: 10:

(ingot)

가 가 가

1a 1d

(2) (2) (1) (3) (1) (1a) ;

(2) (4) (1b) ; (4)

(6) (5) (1c) ; (4) (5) (4)

(7) (1d)

(2) 1a (LOCOS) (1)

(2) (1) (3)

1b (2) (3)

, , (2)
 (4) .
 , 1c , , (5) .
 (4)
 , 1d (4) (5) (6) ,
 (6) (4)
 , (6) , (4)
 (7) .

가 가 , 가 (ingot)

;
 ;
 ;
 ;
 ;

2a 2g , (1)
 (2) (3) , (3) (4)
 (2a) ; (3) , (4) (2)
 (5) (6) (2b) ; (4) (6)
 (7) (2c) ; (CTR)
 (5) (6) (7)가
 (4) (5) (8) (2e) ;
 (CTR) (8) , (8) (2f) ; (CT
 R) (9) , (9) (10) (CTR) (2g)

2a (1) (2) (2)

(2) (3)

(3) (3) (2)
(4) (4)

2b (3) (2)
(4)

(4) (2) (5) (6)

2c (6)
(4) (6) (7)

1d (6) (CTR) (5)
(1) (1) 가

2e (4) (6) (7)가
(5) (5)

2f (5) (CTR) (8) (8)

2g (CTR) (9) (9)
(10) (CTR)

가 (ingot) 가

(57)

1.

3.

1

1a

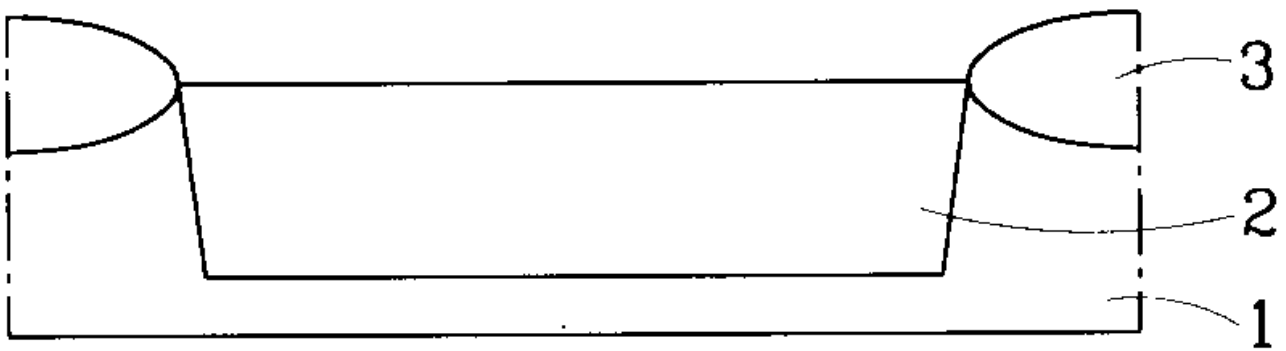

1b

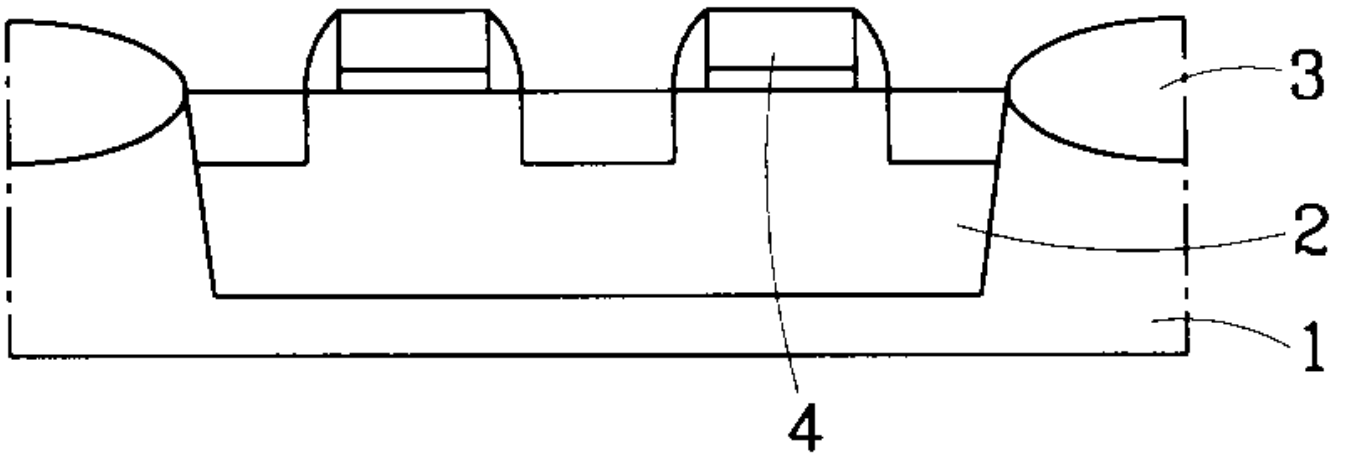

1c

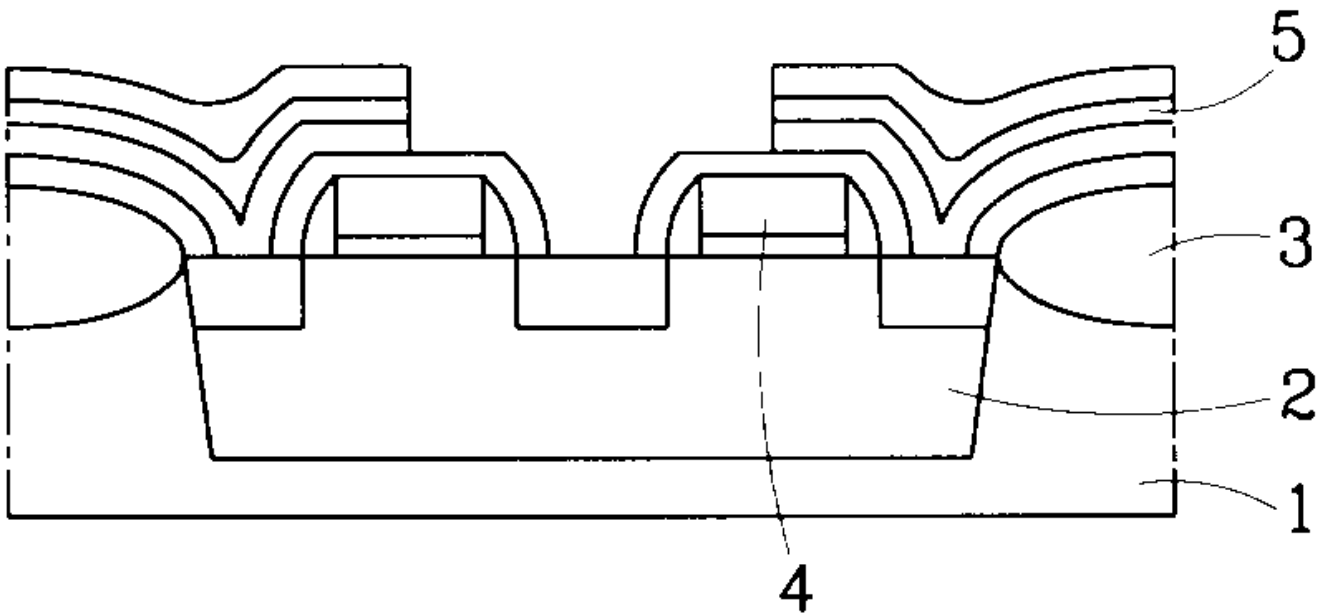

1d

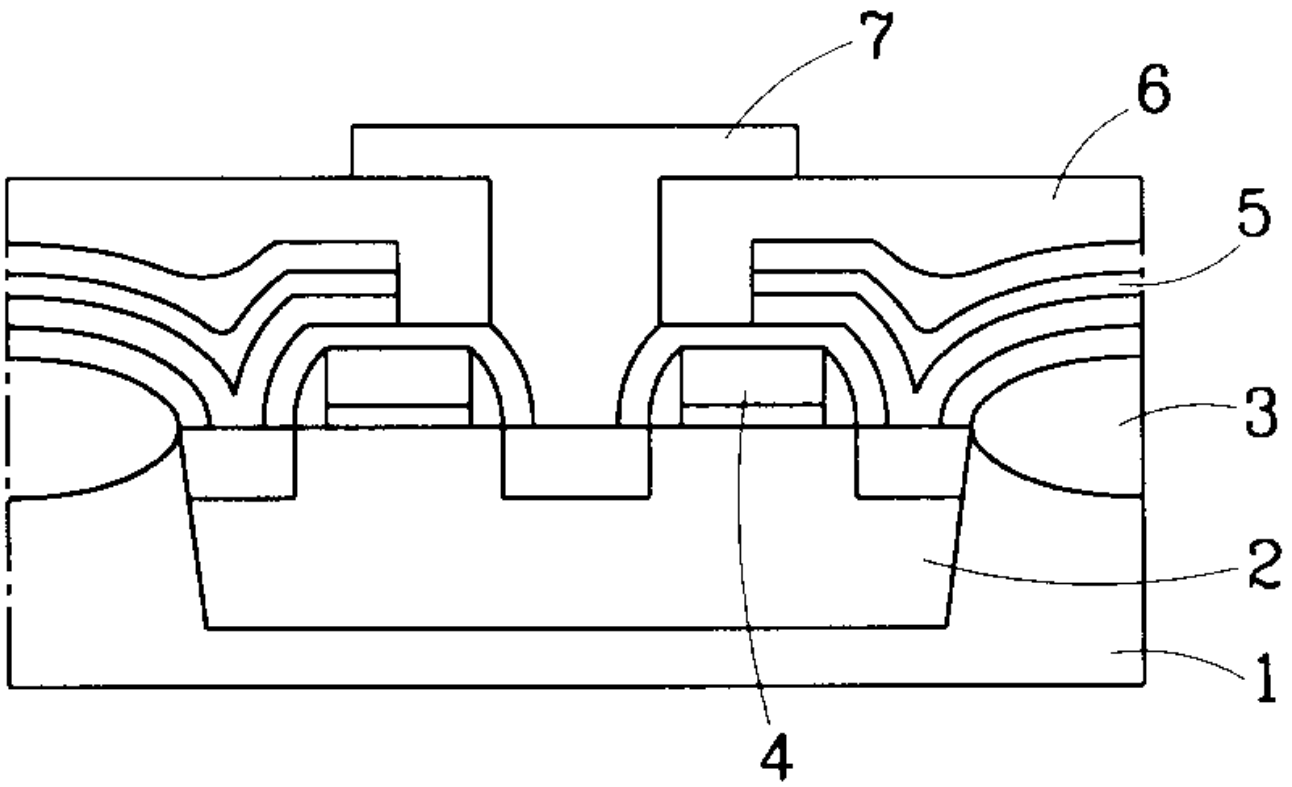

2a

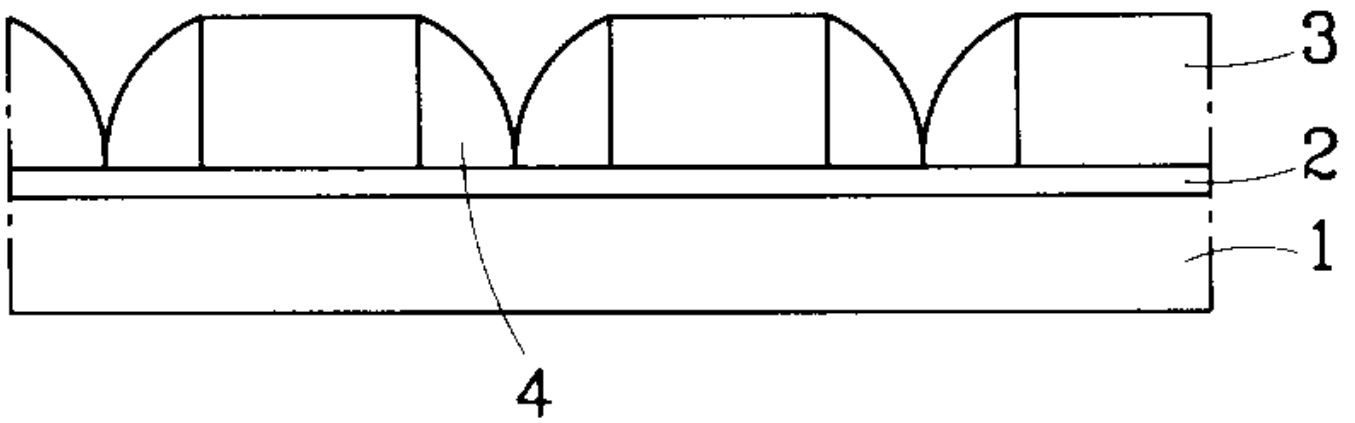

2b

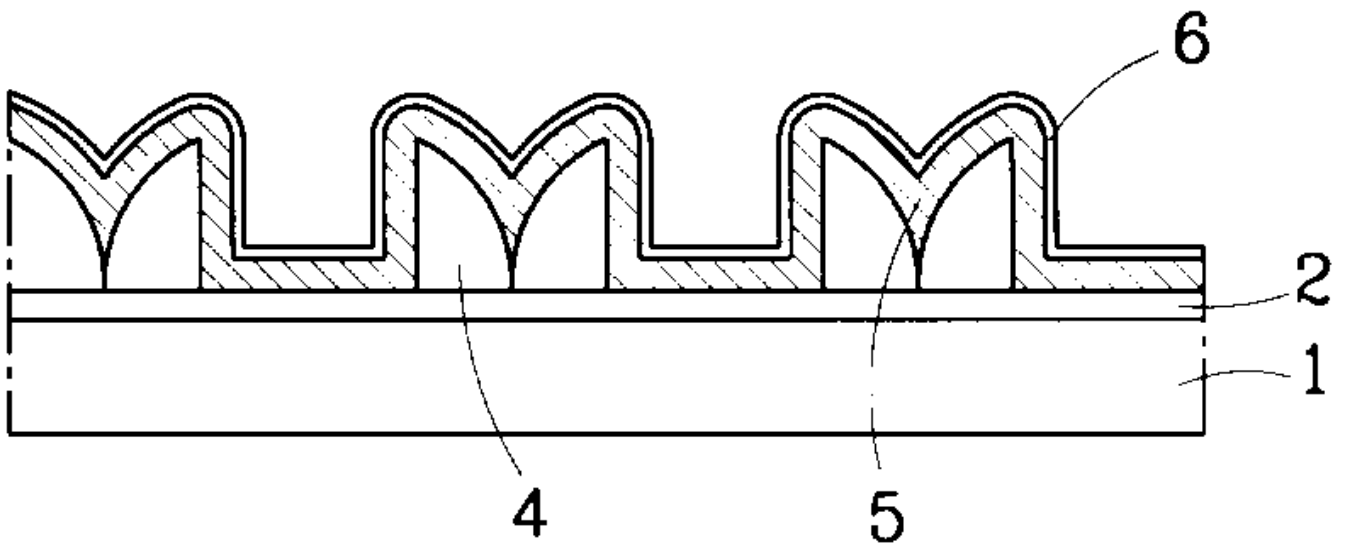

2c

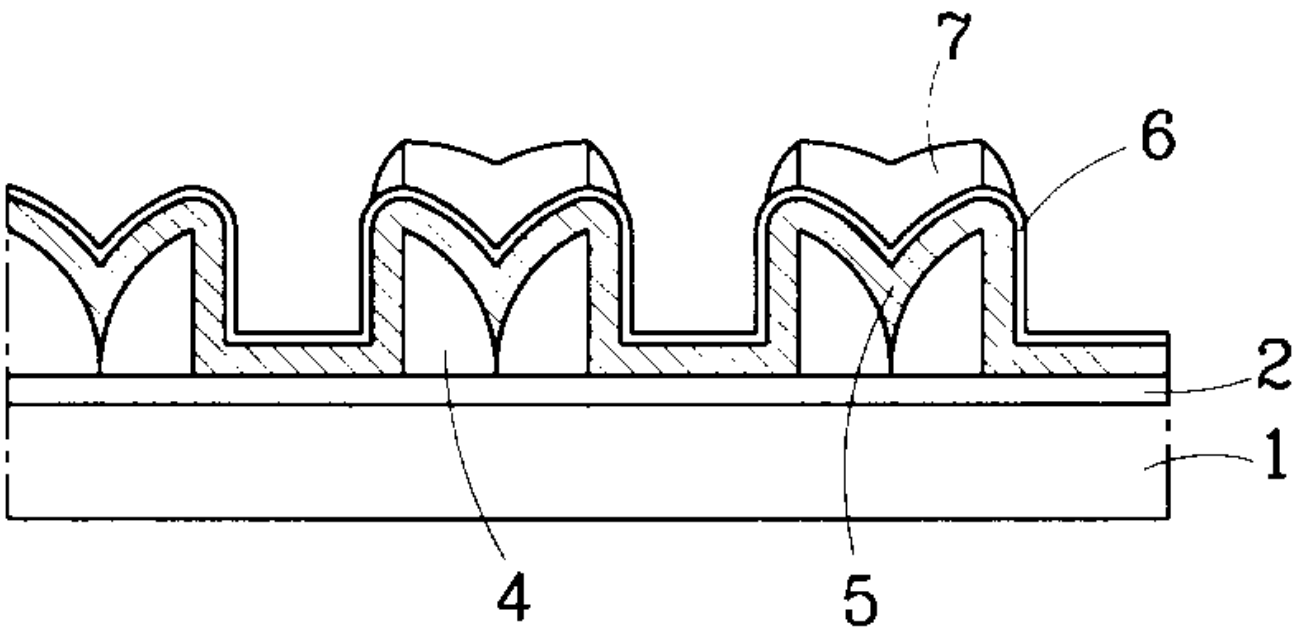

2d

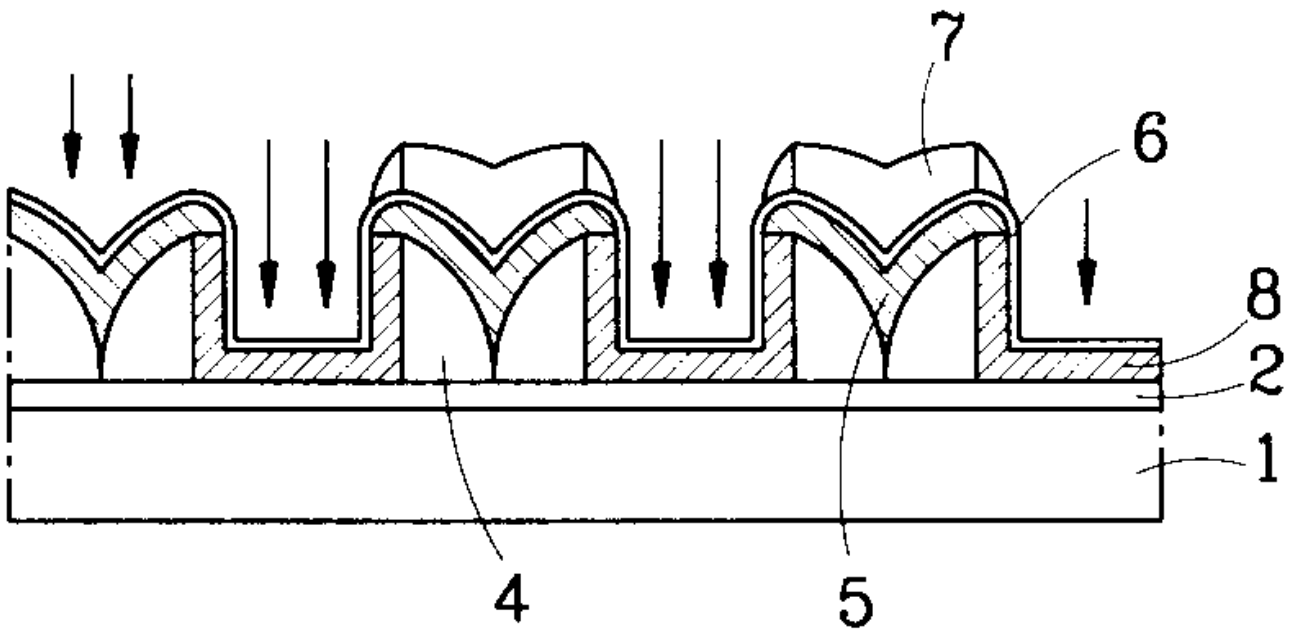

2e

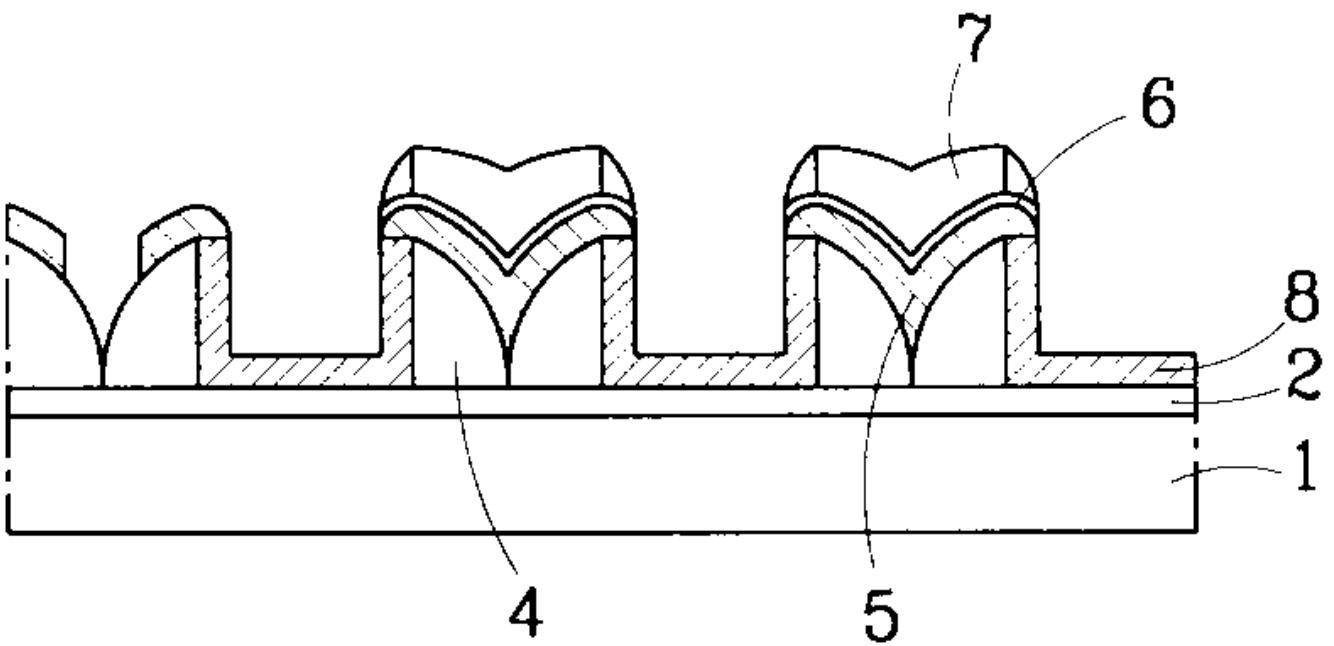

2f

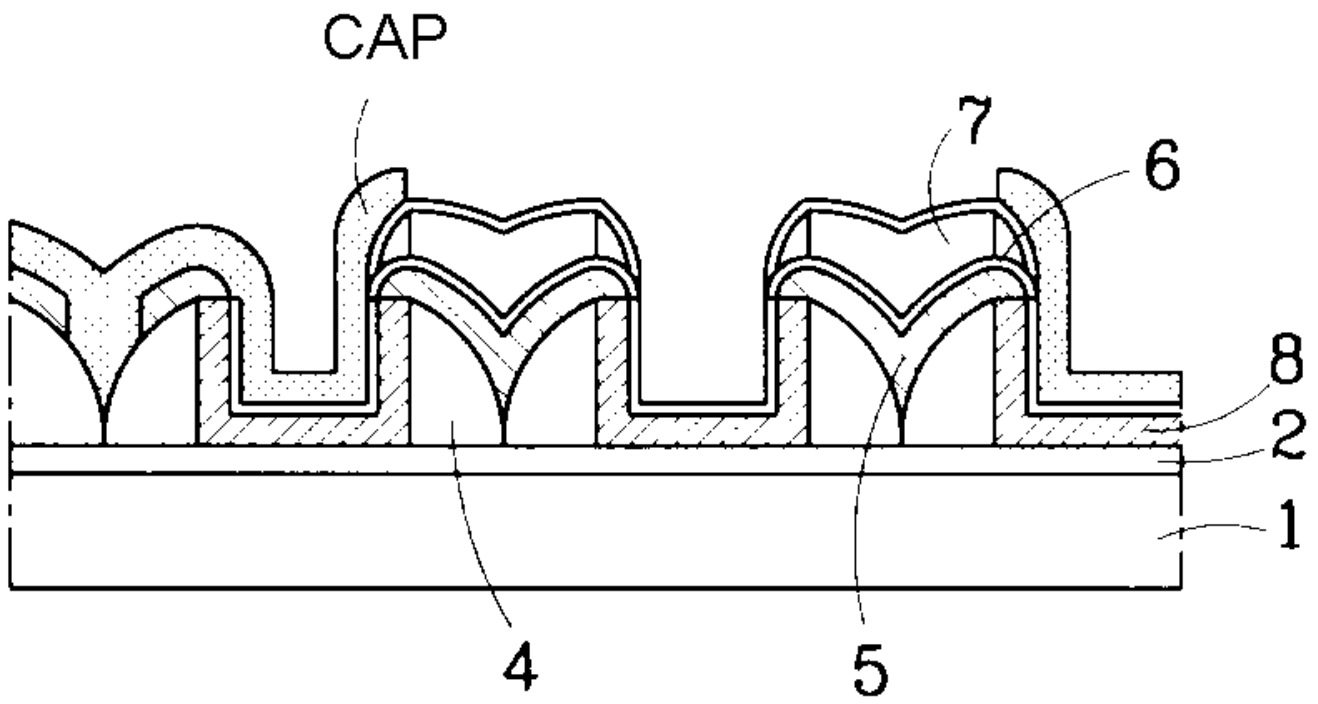

2g

