

(21) Application No 9302074.1  
(22) Date of filing 03.02.1993  
(30) Priority data  
(31) 831376 (32) 03.02.1992 (33) US

(71) Applicant  
Teledyne Industries Inc  
  
(Incorporated in the USA - California)  
  
1901 Avenue of the Stars, Los Angeles,  
State of California 90067, United States of America

(72) Inventors  
Louis Alan D'Andrea  
Roger William Masson

(74) Agent and/or Address for Service  
Lloyd Wise, Tregear & Co  
Norman House, 105-109 Strand, London, WC2R 0AE,  
United Kingdom

(51) INT CL<sup>5</sup>  
G01L 1/22  
(52) UK CL (Edition L)  
G1N NAFD8 N1D2B N1F N7H2 N7J  
(56) Documents cited  
GB 1017898 A EP 0469323 A2 EP 0451636 A1  
EP 0314541 A1 WO 86/01588 A1  
(58) Field of search  
UK CL (Edition L) G1N NAFDR NAFD8 NAGBR  
NAGB8 NAGCR NAGC8 NAGDR NAGD8  
INT CL<sup>5</sup> G01L 1/20 1/22

(54) Strain sensor

(57) A strain sensor adapted for adhesive attachment to an element such as a valve stem includes a sensor circuit coupon 14, a support 12 for the coupon, and clamping means such as blocks 16 carried by the support at the ends thereof (one only shown) for clamping the support around the element during setting of the adhesive. The blocks 16 may then be chiselled off if desired. As described the support 12 is of stainless steel shim stock and the coupon consists of polyimide layers 20, 24 with an inner, etched layer 22 of constantan forming strain gauges and their connecting leads. The gauges are in bridge circuits to measure torque and axial load on a valve stem.

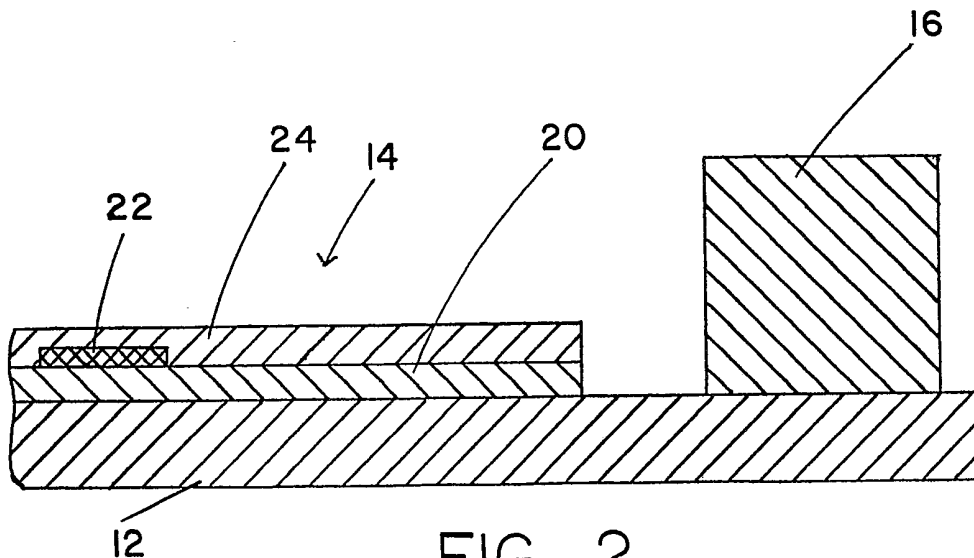

FIG. 2



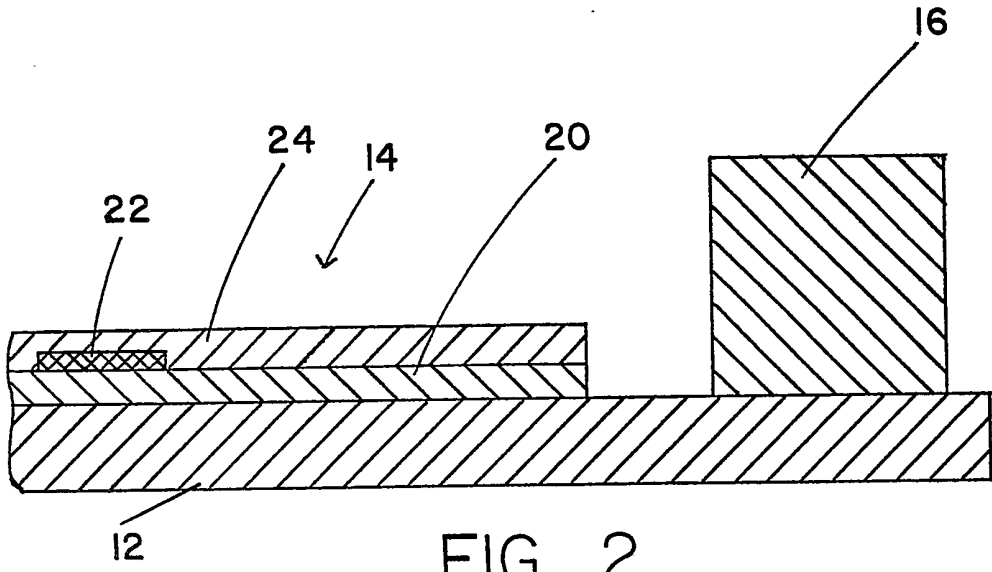

FIG. 2

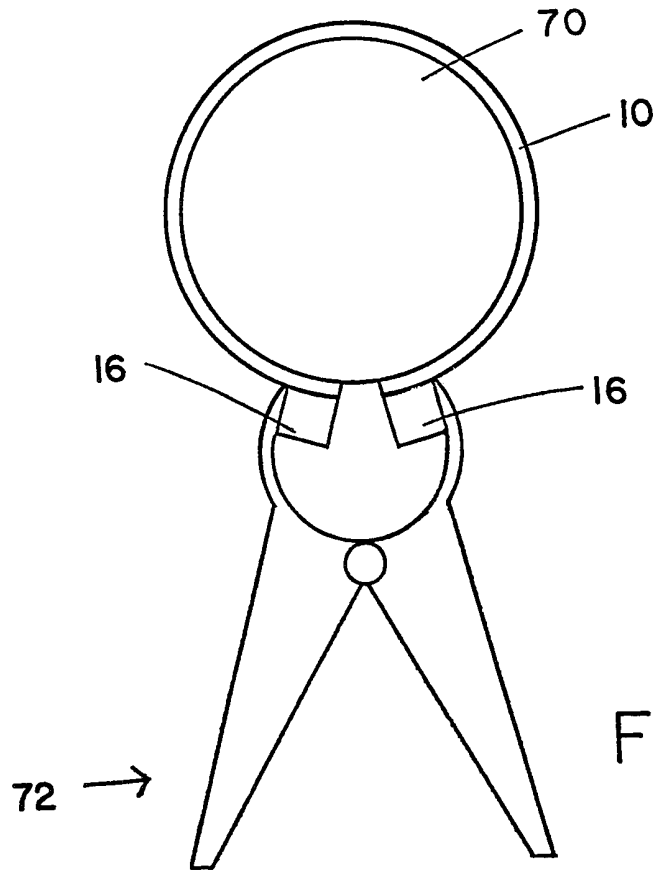

FIG. 3

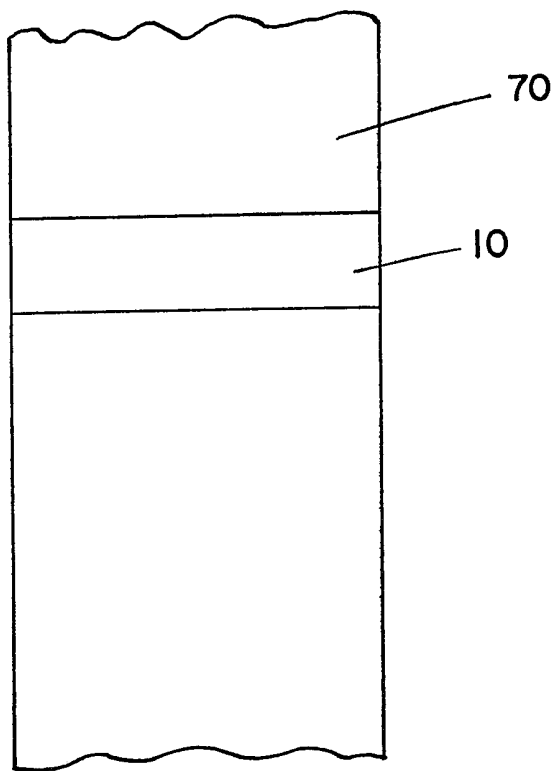

FIG. 4



- 1 -

STRAIN SENSOR

This invention relates to providing for sensing strain, particularly through provision on devices such as valve stems of strain sensors after and while the devices are  
5 already out in the field.

It is known to provide strain sensors on valve stems.

10 We have discovered that strain sensors of the character above mentioned may be suitably and desirably provided by a sensor coupon including a sensor circuit, the coupon being carried by a support adapted to be adhesively secured to a device.

15 In preferred embodiments, the sensor coupon includes an etched circuit encapsulated in a plastic (including both torque and thrust strain gauge circuits), the support is a thin sheet of stainless steel, and the support includes a pair of clamping blocks for drawing the support tightly  
20 about the device.

The presently preferred embodiment is now described, in structure and operation, in the light of the drawings.

25 Fig. 1 is a plan view of said preferred embodiment, circuitry being shown in solid lines even though covered by a thin layer of plastic.

Fig. 2 is a sectional view, enlarged, diagrammatic, and not to scale, taken at 2-2 of Fig. 1.

30 Fig. 3 is a side elevational view of said embodiment being clamped on a valve stem.

Fig. 4 is a view of said embodiment in position on said valve stem.

Fig. 5 is a circuit diagram of the torque bridge portion of the preferred embodiment.

5 Fig. 6 is a circuit diagram of the thrust bridge portion of the preferred embodiment.

There is shown in Fig. 1 a plan view of the preferred embodiment, which is indicated generally at 10. Shim stock 12, of stainless steel 0.003 inches (0.00762 cm) thick, carries thereon coupon 14 and a pair of clamping blocks 16.

Clamping blocks 16 (of carbon steel) are spot-welded to shim stock 12.

15 Coupon 14 includes lower flexible polyimide portion 20, etched constantan circuitry 22, and flexible upper polyimide portion 24, the circuitry being sandwiched between the polyimide portions. Each polyimide portion is one mil ( $2.54 \times 10^{-3}$  cm) thick. The constantan is 200 microinches ( $5.08 \times 10^{-4}$  cm) in thickness.

20 In manufacture, a layer of constantan of the thickness indicated is attached onto lower portion 20. It is then etched to produce both the conductive conduits and pads and the strain gauges. The upper polyimide portion 24 is then overlain. Coupon structures of this character are available from J. P. Technologies, Upland, California.

25 The polyimide-encased coupon 14 is attached to shim stock 12 by means of a cured layer of epoxy adhesive sold under the designation BLH-DPY-500.

30 Turning now to the constantan circuit, there is shown in Fig. 1 torque bridge strain gauge 30, in which the resistance wires etched in the constantan are at an angle of  $45^\circ$ , upwardly rightwardly of Fig. 1. Connected thereto

through connective path 32 is torque bridge strain gauge 34, with its resistance wires etched at a 45° angle upwardly leftwardly of Fig. 1. Connective path 32 connects also with connective path 35, which leads to pad 36. A third torque strain gauge 38 has its resistance "wires" like gauge 30 at an angle of 45° upwardly rightwardly of Fig. 1. The fourth torque strain gauge 40 has its resistance elements oriented as in gauge 34. Gauges 38 and 40 are connected by path 42, which also connects both with path 44 and pad 10 46. Gauges 34 and 38 are respectively connected through paths 48 and 50 to pads 52 and 56.

The circuitry just described is that for the torque strain gauge, and is indicated generally at 58.

Similar circuitry, indicated generally at 60, provides 15 thrust strain gauge circuitry, to measure tension or compression. Circuitry 60 includes strain gauges 62, 64, 66, 68, resistance "wires" in them being oriented, in Fig. 1, respectively, vertical, horizontal, vertical, and horizontal.

The circuitry is shown electrically in Figs. 5 and 6.

20 Fig. 5 illustrates the torque strain gauge bridge. Excitation is through lines 35 (negative) and 44 (positive); the signal is on lines 48, 50 (positive) and 76 (negative). Wires to an outside connector (not shown) are soldered to the pads (e.g., pad 36) electrically connected with the strain 25 gauges. Divided pads (such as 52, 56) leave the option of either shortcircuiting the gap between pads or wiring a resistor therebetween for adjustment in a way well known in the art.

Fig. 6 illustrates the thrust strain gauge.

30 Fig. 3 illustrates the method of mounting sensor 10



on valve stem 70. Stem 70 is cleaned and abraded over the surface to be placed in contact with shim stock 12, the surface of which is also cleaned and abraded to provide improved adhesion. A layer of epoxy adhesive material (suitably that sold by Armstrong Products Co. of Warsaw, Indiana under the designation of A-2) is provided between said surfaces, and the sensor 10 then clamped around valve stem 70 by means of spring clamp 72. While clamp 72 is clamping sensor 10 around stem 70, the adhesive is cured, applying suitable heat for the purpose.

Blocks 16 may then be removed if desired, by means of a chisel or otherwise.

Use of the sensor of the invention permits very rapid installation in the field, something particularly desirable when in the presence of radiation.

CLAIMS

1. A strain sensor comprising a support, and a strain gauge coupon mounted on said support.
2. The sensor of claim 1 in which said coupon includes a torque bridge circuit and a thrust bridge circuit.
3. The sensor of claim 2 in which each said circuit is a portion of an etched layer.
4. The sensor of claim 3 in which said layer is of constantan.
5. The sensor of claim 2 in which said coupon comprises at least one strain gauge circuit.
6. The sensor of claim 2 in which each said circuit is encapsulated in plastic.
7. The sensor of claim 1 in which said support carries a pair of clamping means.
8. The sensor of claim 7 in which said support is shim stock.
9. The sensor of claim 8 in which said clamping means is spot welded to said shim stock.
10. A strain sensor substantially as hereinbefore described with reference to and as shown in the accompanying drawings.

**Patents Act 1977**  
**Examiner's report to the Comptroller under**  
**Section 17 (The Search Report)**

Application number

GB 9302074.1

**Relevant Technical fields**

- (i) UK CI (Edition L ) G1N (NAGB8, NAGBR, NAGC8, NAGCR,  
 NAGD8, NAGDR, NAFD8, NAFDR)
- (ii) Int CI (Edition 5 ) G01L 1/20, 1/22

**Search Examiner**

M G CLARKE

**Databases (see over)**

- (i) UK Patent Office
- (ii)

**Date of Search**

5 APRIL 1993

Documents considered relevant following a search in respect of claims 1 TO 10

Category (see over)	Identity of document and relevant passages	Relevant to claim(s)
X Y	GB 1017898 (PHILIPS ETC) whole document	1, 3
X P	EP 0469323 A2 (HOTTINGER BALDWIN) whole document	1, 4
Y	EP 0451636 A1 (HOTTINGER BALDWIN) see especially column 5 lines 1-42	3, 4, 6
X Y	EP 0314541 A1 (COMM A L'ENERGIE ATOMIQUE) whole document	1, 3, 4
X	WO 86/01588 A1 (UNIVERSITY OF STRATHCLYDE) see especially Figure 1 and page 5 line 30 - page 6 line 10	1, 8



- + -

Category	Identity of document and relevant passages	Relevant to claim(s)

**Categories of documents**

**X:** Document indicating lack of novelty or of inventive step.

**Y:** Document indicating lack of inventive step if combined with one or more other documents of the same category.

**A:** Document indicating technological background and/or state of the art.

**P:** Document published on or after the declared priority date but before the filing date of the present application.

**E:** Patent document published on or after, but with priority date earlier than, the filing date of the present application.

**&:** Member of the same patent family, corresponding document.

**Databases:** The UK Patent Office database comprises classified collections of GB, EP, WO and US patent specifications as outlined periodically in the Official Journal (Patents). The on-line databases considered for search are also listed periodically in the Official Journal (Patents).