

REPUBLIC OF SOUTH AFRICA
PATENTS ACT, 1978**PUBLICATION PARTICULARS AND ABSTRACT**

(Section 32(3)(a) – Regulation 22(1)(g) and 31)

OFFICIAL APPLICATION NO.

LODGING DATE

ACCEPTANCE DATE

21	01	20011100
----	----	----------

22	8 FEB 2001
----	------------

43	26-11-2001
----	------------

INTERNATIONAL CLASSIFICATION

NOT FOR PUBLICATION

51	C12N; C12P; C07K
----	------------------

CLASSIFIED BY: WIPO

FULL NAMES OF APPLICANT

71	BIOSOURCE TECHNOLOGIES, INC. LARGE SCALE BIOLOGY CORP. AANSOEKERS VERVANG APPLICANTS SUBSTITUTED 23/11/01.
----	---

FULL NAMES OF INVENTORS

72	1. TURPEN, THOMAS H AND 5 OTHERS: SEE ATTACHED SCHEDULE.
----	---

EARLIEST PRIORITY CLAIMED

COUNTRY

NUMBER

DATE

33	US
----	----

31	09/132,989
----	------------

32	11 AUG 1998
----	-------------

TITLE OF INVENTION

54	METHOD FOR RECOVERING PROTEINS FROM THE INTERSTITIAL FLUID OF PLANT TISSUES
----	---

57	ABSTRACT (NOT MORE THAN 150 WORDS)
----	------------------------------------

NUMBER OF SHEETS	97
------------------	----

If no classification is finished, Form P.9 should accompany this form.
The figure of the drawing to which the abstract refers is attached.

Abstract

A method for extracting proteins from the intercellular space of plants is provided. The method is applicable to the large scale isolation of many active proteins of interest synthesized by plant cells. The method may be used commercially to recover recombinantly produced proteins from plant hosts thereby making the large scale use of plants as sources for recombinant protein production feasible.

METHOD FOR RECOVERING PROTEINS FROM THE INTERSTITIAL FLUID OF PLANT TISSUES

5 FIELD OF THE INVENTION

The present invention relates generally to the field of protein production and purification. More specifically, the present invention relates to a method for isolating commercial scale quantities of highly concentrated, active proteins from the intercellular material of plants via a vacuum and centrifugation process which does not destroy the plant
10 material, permitting secondary protein extraction from the plant material.

BACKGROUND OF THE INVENTION

There are many examples of valuable proteins that are useful in pharmaceutical and industrial applications. Often these molecules are required in large quantities and in partially
15 or highly purified formulations to maintain product quality and performance. Plants are an inexpensive source of proteins, including recombinant proteins. Many have proposed the desirability of producing proteins in large amounts in plants. However, the problems associated with extracting and processing products from homogenized plant tissues as well as purifying and recovering the recombinant protein product have been recognized as
20 substantial. Austin *et al.* *Annals New York Academy of Science*, 721:234-244 (1994). These problems represent major impediments to successful recombinant protein production in plants on a large and commercially valuable scale.

Plant cells are thought to synthesize proteins on the membranes of the endoplasmic reticulum and transport the proteins synthesized to the cell surface in secretory vesicles
25 formed at the Golgi apparatus. A discussion of the topic is provided by Jones *et al.*, *New Phytology*, 111:567-597 (1989). Significant research has been devoted to elucidating the specific mechanisms related to protein secretion for several particular proteins in specific plant tissues or cell cultures. Examples of such efforts are presented by Herbers *et al.*, *Biotechnology* 13:63-66 (1995), Denecke *et al.*, *The Plant Cell* 2:51-59 (1990), Melchers *et al.*, *Plant Molecular Biology* 21:583-593 (1993) and Sato *et al.*, *Biochemical and*
30

Research Communications 211(3):909-913 (1995). In the case of proteins not secreted into the plant cell apoplasm or intercellular space, a mechanism for lysing the plant cell wall must be utilized in order to release and capture the protein of interest. Plant cells must be exposed to very high shear forces in order to break the cell walls and lyse cellular membranes to release intracellular contents. Proteins of interest, whether recombinantly produced or naturally produced by the subject plant, are thereby exposed to a hostile chemical environment and are particularly subject to oxidative and proteolytic damage due to the exposure of the product to enzymes and small molecules that were compartmentalized before homogenization of the tissue. In addition, most of the other total cellular protein is mixed with the protein of interest creating formidable purification problems if such a cell lysis procedure is performed. In order to use the biosynthetic capacity of plants for reliable protein production, a process to obtain specific proteins that can be secreted into the intercellular space (apoplasm) of plant tissues is desirable. Such a procedure would forego the need for homogenization. If such a procedure is performed, the fraction of plant material containing one or more proteins of interest might be obtained without homogenization. Therefore, such a procedure provides that the plant extract is enriched for the particular protein of interest, and the protein is protected from some chemical and enzymatic degradation.

Since the valuable proteins and products of interest are partitioned or secreted into the interstitial spaces, vacuum pressure facilitates the introduction of infiltration medium into the interstitial space. Similarly, various forces can be applied to remove the retained fluid. Centrifugal force of 1,000 x G is effective. Using gravity, the retained fluid can be collected in a trap under vacuum. With or without vacuum infiltration of a buffer, the enzyme can be recovered by freezing the tissue, thawing and applying a physical press to recover the fluid. However, such a procedure results in an undesirable increased cellular lysis.

Genetically modified plants are a reliable source for the production of recombinant proteins. Because the biological product is accumulated under nonsterile growth conditions and the production may be scaled to the quantities desired in a relatively inexpensive manner, it is feasible to exploit a dilute but enriched source such as the interstitial fluid fraction as a

source for harvesting proteins of interest on an industrial scale. A variety of proteins of interest may be harvested from recombinant plant sources, however, highly active, pharmaceutical quality enzymes, cytokines and antibodies are particularly valuable products that can be developed by this process.

5

SUMMARY OF THE INVENTION

The present invention features a method for extracting highly concentrated, active proteins from the intercellular space of plants. The intercellular space consists of a matrix of fluid, protein and cell wall carbohydrates. The method is applicable to the large, commercial-
10 scale isolation of proteins desired from plant cells whether such proteins are naturally occurring or are produced by recombinant technology. The vacuum and centrifugation process, as explained below, allows extraction of protein from the interstitial fluid of the plant without destroying the plant material, permitting further extraction of desired protein from the plant material.

15 In a broad aspect, the method comprises infiltrating plant leaves with a buffer solution by subjecting submerged plant foliage to a substantially vacuum environment, removing the excess liquid from the plant foliage after exposing the foliage to the substantially vacuum environment, and centrifuging the foliage to obtain the interstitial fluid. As a result of such a procedure, large amounts of desirable proteins may be removed from the intercellular space
20 of plants thereby making it feasible to isolate naturally-occurring proteins from plant foliage and making it possible to produce recombinantly the desired proteins in plants and recover the same in commercially valuable quantities without homogenizing the plant foliage or otherwise significantly lysing the plant cells themselves. This material is referred to as an interstitial fluid, hereinafter "IF", IF extract.

25 In one embodiment, the subject plant leaves are dissected completely or substantially down the midrib (substantially in halves) before exposing them to the buffer solution. In another preferred embodiment, the leaves and buffer solution are subjected to a vacuum pressure of about 200 to 1000 mm Hg. Even more preferably, the leaves and buffer solution

are subjected to a vacuum pressure of about 400 to 760 mm Hg. And most optimally, the leaves and buffer solution are subjected to a vacuum pressure of about 760 mm Hg. In yet other preferred embodiments, the leaves are subjected to a low speed centrifugation having a G-force range of about 50 to 5,000 x G or less after the excess buffer solution is removed.

5 Most preferably, the leaves are subjected to centrifugation having a G-force of about 2,000 x G.

BRIEF DESCRIPTION OF THE FIGURES

- 10 **Fig. 1** General Overview Of The IF Extraction Process
- Fig. 2** Batch Vessel Infiltration
- Fig. 3** Continuous Vacuum Infiltration
- Fig. 4** Plasmid map of TT01A 103L
- Fig. 5** Viral cDNA Sequence of Plasmid TT01A 103L

15

DETAILED DESCRIPTION OF THE INVENTION

The present invention features a method for extracting proteins from the intercellular space of plants. The method is applicable to the large-scale commercial isolation of highly concentrated and active proteins desired from plant cells whether such proteins are naturally occurring or are produced by recombinant technology, including the use of plant viral vectors or the use of transgenic plants. The vacuum and centrifugation process of the present invention permits extraction of protein from the intercellular space without destroying the plant material, thereby permitting further secondary extraction of desired proteins from the plant material. These proteins derived from the secondary extraction process can be either the same or different as those proteins purified from the IF fluid.

20

25

The method generally comprises the steps of infiltrating plant foliage with a buffer solution by subjecting the submerged plant foliage to a substantially vacuum environment, removing the excess liquid from the plant foliage after exposing the foliage to the

substantially vacuum environment, and centrifuging the foliage. As a result of such procedure, large amounts of desirable proteins may be removed from the intercellular space of plants thereby making it feasible to isolate both naturally-occurring and recombinantly produced proteins from plant foliage in commercial-scale quantities without homogenizing the plant cells, allowing secondary extraction of desired protein from the plant cell material.

Work has been conducted in the area of developing suitable vectors for expressing foreign DNA in plant hosts. Ahlquist, U.S. Patent 4,885,248 and U.S. Patent 5,173,410 describes preliminary work done in devising transfer vectors which might be useful in transferring foreign genetic material into a plant host for the purpose of expression therein.

Additional aspects of hybrid RNA viruses and RNA transformation vectors are described by Ahlquist *et al.* in U.S. Patents 5,466,788, 5,602,242, 5,627,060 and 5,500,360 all of which are herein incorporated by reference. Donson *et al.*, U.S. Patent 5,316,931 and U.S. Patent 5,589,367, herein incorporated by reference, demonstrate for the first time plant viral vectors suitable for the systemic expression of foreign genetic material in plants. Donson *et al.* describe plant viral vectors having heterologous subgenomic promoters for the stable systemic expression of foreign genes. Hence, the use of plants to produce recombinant proteins on a commercial scale is now possible. The present application solves the problem of extracting these proteins of interest from the interstitial fluid of plant foliage.

Protein secretion in plants is a fundamental yet not fully understood process. It is known that secreted proteins are synthesized on the membranes of the rough endoplasmic reticulum and transported to the cell surface by secretory vesicles formed on the Golgi apparatus. Moreover, it is known that a signal peptide is required for translocation of the secreted proteins across the endoplasmic reticulum. Proteins which are transported into the lumen of the endoplasmic reticulum may then be secreted into the interstitial space provided they are not sorted by the cell to another compartment such as the vacuole.

As knowledge about this process increases, it may be possible to design recombinant proteins which are specifically intended for secretion into the interstitial space of plant cells in which they are produced.

If a significant percentage (approximately 10% or greater) of the total product is secreted then it may be preferable to isolate proteins of interest from the intercellular space of plants. Otherwise, a mechanism for lysing the plant cell wall must be utilized in order to release and capture the protein of interest. Plant cells must be exposed to very high shear forces in order to break the cell walls and lyse cellular membranes to release intracellular contents. Proteins of interest, whether recombinantly produced or naturally produced by the subject plant, are thereby exposed to a hostile chemical environment and are particularly subject to oxidative and proteolytic damage that is often enzymatically catalyzed. In addition, most of the other total cellular protein is mixed with the protein of interest creating formidable purification problems if such a cell lysis procedure is performed.

Intercellular fluid extracts have previously been prepared from vacuum infiltrated foliage for a variety of experimental purposes. These extracts are comprised of proteins, both native and nonnative, as well as other molecules. In Klement, Z. (1965) *Phytopathological Notes*:1033-1034, the growth promoting properties of the extract were documented using a plant pathogenic bacterial species. Using marker enzymes for the IF and cytosolic compartments of the plant leaf cell, Rathmell and Sequera (1974), *Plant Physiol.* 53:317-318 confirmed the enrichment of a specifically secreted protein fraction and noted the utility of these extracts in basic research studies pertaining to biochemical and physiological investigations. Parent and Asselin (1984) *Can. J. Bot.* 62:564-569, characterized a number of proteins that were induced by pathogen stress and secreted in the IF (pathogenesis-related or PR proteins) and the method was applied to localize enzymatic activities and proteins to subcellular compartments. Van den Blucke *et. al.* (1989) *PNAS* 86:2673-2677; Heitz *et al.* (1991) *Plant Physiol.* 97:651-656. Regalado and Ricardo (1996) *Plant Physiol.* 110:227-232 noted that specific IF proteins appear to be constitutively expressed.

Depending on the buffer composition and treatment, there may be various additional components in IF extracts including, for example, components originating from the rough and smooth endoplasmic reticulum, the golgi apparatus, the nucleus, the vacuole, the plasma transmembrane, the cytosol, the mitochondria, the chloroplasts, peroxisomes, any associated

membranes and organelles.

In genetically modified plants, IF extraction methods as well as other methods have been used to demonstrate the subcellular localization of a portion of the recombinant product.

Sijomns *et al.* (1990) *Bio/Technology* 8:217-221; Firek *et al.* (1993) *Plant Molecular Biology* 23:861-870; Voss *et al.* (1995) *Molecular Breeding* 1:39-50; De Wilde *et al.* (1996) *Plant Science* 114:233-241. IF extracts have been used as a starting material to purify small quantities of plant or plant pathogen-derived proteins for biochemical characterization. Melchers *et al.* (1993) *Plant Molecular Biology* 21:583-593; Sato *et al.* (1995) *BBRC* 211:909-913; Kinai *et al.* (1995) *Plant Cell* 7:677-688; Liu *et al.* (1996) *Plant Science* 121:123-131; Maggio *et al.* (1996) *Plant Molecular Biology Reporter* 14:249-259.

Therefore, there is a need to isolate an extracted material having a higher specific activity of the active material (U activity/mg protein) and, therefore, this provides an enrichment process of IF components at commercial scale.

It is not appreciated in the prior art that IF extracts might be generally useful as starting material for the large scale purification of highly active and potent biochemicals that may, for example, have applications as a source of human therapeutics. Often other methods of purification are pursued even when the product is shown to be secreted (Herbers *et al.* 1995, *supra*). The failure to develop the IF method as a commercially feasible source of recombinant protein products is due to a combination of the following factors: 1) an incomplete characterization of the extracts, i.e. a determination of what percent of the total recombinant protein can be obtained by IF methods at what level of enrichment, 2) failure by others to demonstrate suitable activity of a product in a highly purified form and 3) a lack of description of industrial-scale equipment to process reasonable quantities of biomass for this purpose.

The present invention involves a vacuum and centrifugation process to provide for commercial-scale protein extraction from plants. As a result of the present invention, large amounts of active proteins of interest may be removed from the intercellular space of plants and concentrated for further purification thereby making it feasible to isolate naturally-

occurring and recombinantly-produced proteins from plant foliage in commercially valuable quantities. This process has an additional advantage in that the resulting plant tissue following IF extraction is not destroyed and may be used for recovery of other valuable components by other means.

5 The foliage may be harvested in any manner that is convenient. In a preferred embodiment, the subject plant leaves are removed from the plant and are dissected completely or substantially lengthwise parallel to the midvein substantially in halves before exposing them to a buffer solution such that the ends of numerous large lateral veins are exposed.

10 Once the leaves are cut, they may be exposed to a buffer solution. A routine EDTA or Tris buffer solution is suitable, though those skilled in the art will appreciate that any buffer may be more or less appropriate for a given plant or protein of interest. In some instances, water may be acceptable or even preferred as a solution. It is not contemplated that the nature of the buffer solution, specific pH or temperature are crucial to the embodiments within the
15 scope of the invention. However, it is generally recommended to maintain conditions which avoid oxidation, precipitation, proteolysis or denaturation of the one or more proteins of interest. Thus, pH, temperature, and other such variables should be monitored and altered as needed.

 Once the leaves of the plant have been placed in a buffer solution, they are subjected
20 to a substantially vacuum environment. It is believed that vacuum pressure expedites soaking of the buffer solution by the leaf. In some embodiments, the vacuum pressure may be about 200 to 760 mm Hg. Most preferably, the leaves and buffer solution are subjected to a vacuum pressure of about 400 to 760 mm Hg. The amount of vacuum pressure may be varied within the scope of the invention. Also, the duration may be varied within the scope of the
25 invention, however, exposure to a vacuum environment for durations of around a few seconds to 10 minutes has proven especially effective. In some embodiments of the invention, the leaves in buffer solution are exposed to a vacuum environment repeatedly. It is believed that one to three separate exposures may be especially effective. However, the number of

exposures, duration of exposure and amount of force of the vacuum may be adjusted according to the preferences of the practitioner and to capture the most efficient embodiments of the method as it applies to specific plants and proteins of interest. Additionally, one skilled in the art can envision that molecules or products of interest other than peptides and proteins could be recovered from the interstitial fluid using methods generally described in the instant invention. For example, the methods described in the instant invention can be used to recover lipids, carbohydrates, lipoproteins, sugars, polysaccharides, fatty acids, nucleic acids and polynucleotides.

The plant tissue is then removed from the buffering solution. They may or may not be subjected to a desiccation step to remove the buffer as the need or desire dictates. The leaves may then be placed in any convenient geometric array for centrifugation. In preferred embodiments the leaves are transferred from the centrifuge by means of a discontinuous discharge basket centrifuge rotor. When a discontinuous discharge basket centrifuge rotor is used, an initial spin is performed to move the biomass to the wall of the rotor and then the full-speed spin is performed. In especially preferred embodiments, it is contemplated that a large volume of leaves will be simultaneously subjected to the vacuum and centrifuging devices. Thus, it is anticipated that large, commercially available vacuum pumps and basket centrifuges such as those made by Heine®, Ketna® or Sandborn® will be used in the subject method. It is especially preferred to assemble the leaves in bags for a basket centrifuge.

The leaves may then be subjected to centrifugation after the excess buffer solution is substantially removed. In preferred embodiments, it is contemplated that low speed centrifugation is appropriate. By low speed centrifugation is meant about 5,000 x G or less. By the centrifugation procedure, the interstitial fluid is removed from the plant. The interstitial fluid may be collected in any convenient collecting device, e.g., a tank, or directed to additional purification equipment, e.g., chromatography and ultrafiltration.

Once the interstitial fluid is collected from plant leaves, the one or more proteins of interest may be concentrated and purified according to any suitable purification procedures. Such procedures may include but are not limited to protein precipitation, expanded bed

chromatography, ultrafiltration, anion exchange chromatography, cation exchange chromatography, hydrophobic-interaction chromatography, HPLC, FPLC and affinity chromatography. A general discussion of some protein purification techniques is provided by Jervis *et al.*, *Journal of Biotechnology* 11:161-198 (1989), the teachings of which are herein
5 incorporated by reference.

It is contemplated that the method of the present invention is useful with any and all plant tissues (such as leaves, roots, shoots, stems, flowers, fruits, embryos, seedlings) that may be treated as saturated solids after vacuum infiltration. For example, this may include germinating embryos and seedlings. However, plants possessing substantially symmetrical
10 leaves with a midrib may be especially useful in the present method because the interstitial fluid may be more easily obtained from such leaves as a result of the highly suitable morphology. In especially preferred embodiments, the plant used is tobacco since tobacco has proven to be especially useful in producing recombinant proteins of interest on a large scale. However, it is not intended that the present invention be limited to any particular plant
15 species or tissues.

The following definitions are provided merely to clarify the present invention:

By "vacuum environment" is meant any environment regardless of the confines defining the same and regardless to the mechanism producing the same in which the atmospheric pressure has been substantially reduced from that observed under normal
20 conditions at sea level.

By "protein of interest" is meant any complete protein or peptide or fragment thereof whether naturally occurring in a cell or produced therein by recombinant methods. The term is intended to encompass amino acid sequences which are glycosylated as well as those which are not glycosylated. The term is also intended to encompass sequences which are naturally
25 occurring or wild type and those which have been modified or mutated, including modification to include a signaling peptide sequence which causes the protein to be directed

to a specific compartment within the cell. The term is also intended to encompass protein fusions.

By "interstitial fluid" is meant the extract obtained from all of the area of a plant not encompassed by the plasmalemma i.e., the cell surface membrane. The term is meant to include all of the fluid, materials, area or space of a plant which is not intracellular (wherein intracellular is defined to be synonymous with innercellular) including molecules that may be released from the plasmalemma by this treatment without significant cell lysis. Synonyms for this term might be exoplasm or apoplasm or intercellular fluid or extracellular fluid. Interstitial fluid is abbreviated in the instant invention as IF.

10

EXAMPLES OF THE PREFERRED EMBODIMENTS

The following examples further illustrate the present invention. These examples are intended merely to be illustrative of the present invention and are not to be construed as being limited.

15

These experiments demonstrate that a significant portion of the total protein in the leaf can be simply recovered from the interstitial fraction while enriching for purity. These experiments further demonstrate that the methods are useful for the isolation of highly active products on a very large scale. Those skilled in the art may optimize the process for numerous variables specific for each protein such as buffer composition and temperature, etc.

20

EXAMPLE 1

Extraction of α -Trichosanthin protein

α -Trichosanthin (α -TCS) is a eukaryote ribosome-inactivating enzyme that cleaves an N-glycosidic bond in 28S rRNA. α -TCS, as well as other ribosome-inactivating proteins and conjugates are being evaluated as therapeutics for cell-directed death. In previous work we demonstrated that plants transfected with a proprietary RNA viral vector produce recombinant α -TCS to 2% of the total soluble leaf protein with high fidelity (Kumagai *et al.*

PNAS 90:427-430 (1993)).

Leaves from plants transfected with the vector TB2 (ATCC Deposit No. 75280) were removed at the petiole and slit down the midrib into two equal halves. To obtain a total cellular homogenate, one group of half-leaves was ground in the presence of 4 volumes of detergent extraction buffer (100 mM potassium phosphate pH 6.5 mM EDTA, 10 mM, α -mercaptoethanol and 0.5% w/v sodium taurocholate) with a mortar and pestle after freezing the tissue in liquid nitrogen. To recover the interstitial fluid (IF), the same enzyme extraction buffer was infiltrated into the opposing group of half-leaves by submerging the tissue and pumping a moderate vacuum (500 mm Hg). After draining off excess buffer, the undisrupted half-leaves were rolled gently in parafilm, placed in disposable tubes and the interstitial fluid (IF) was collected by low-speed centrifugation (1,000 x G) for a period of 5-15 minutes. The weight of buffer recovered from the infiltrated leaf tissue is recorded and varies from approximately one-half to equal the original weight of the leaf. α -TCS expression in IF extracts was confirmed by Western analysis and levels were quantified using a densitometer tracing of a Coomassie-stained gel. Total protein was determined by the method described by Bradford. Bradford, *Anal. Biochem* 72:248 1976.

The following data presented as Table 1 demonstrate that recombinant α -TCS, shown in previous work to retain full enzymatic activity, may be successfully extracted from the interstitial fluid of plant leaves using the present method. The IF method results in a recovery of 9% of the total α -TCS of the leaf at a 6-fold enrichment relative to an extract obtained by homogenization (H). The α -TCS production results may be improved by optimizing the time post-inoculation with the viral vector and minimizing the contamination of viral coat protein in the interstitial fraction.

Table 1

Sample	Fresh Weight (gr)	Total Volume (ml)	Protein Conc. (mg/ml)	Total Protein (mg)	Protein Yield (mg/gr)	Rprotein Conc. (mg/ml)	Total RProtein (mg)	IRprotein Yield (mg/gr)	%Recovery RProtein In IF	X-Fold Purification
TB2/IF	8.00	7.8	0.13	1.03	0.13	ND	ND	ND	ND	ND
TB2/TCS/IF	8.00	8.3	0.14	1.20	0.15	0.017	0.143	0.018	9	6
*TB2/TCS/H	ND	ND	ND	80.00	ND	ND	1.600	ND	ND	ND
*Calculated from PNAS 90:427-430 (1993)										

13

5

IF = interstitial fluid extraction

H = homogenization extraction

10

ND = Not determined

EXAMPLE 2Extraction of Amylase protein

Amylase (AMY) is an important industrial enzyme used to degrade starch. Leaves from plants transfected with the vector TT01A 103L were removed at the petiole and slit
5 down the midrib into two equal halves. The plasmid map of TT01A 103L is shown in Figure 4. The viral cDNA sequence of plasmid TT01A 103L is shown in Figure 5 SEQ ID NO: 1. To obtain a total cellular homogenate, one group of half-leaves was ground in the presence of 4 volumes of detergent extraction buffer (100 mM potassium phosphate pH6.5, 5 mM EDTA, 10 mM, α -mercaptoethanol and 0.5% w/v sodium taurocholate) with a mortar and pestle after
10 freezing the tissue in liquid nitrogen. To recover the interstitial fluid (IF), the same enzyme extraction buffer was infiltrated into the opposing group of half-leaves by submerging the tissue and pumping a moderate vacuum (500 mm Hg). After draining off excess buffer, the undisrupted half-leaves were rolled gently in parafilm, placed in disposable tubes and the interstitial fluid (IF) was collected by low-speed centrifugation (1,000 x G for about 15
15 minutes). The weight of buffer recovered from the infiltrated leaf tissue is recorded and varies from approximately one-half to equal the original weight of the leaf. AMY expression in IF extracts was quantified using a commercially available enzyme assay reagents and protocol. Total protein was determined by the method described in Bradford, *Anal. Biochem* 72:248 1976. The AMY enzyme assay is described in Sigma Procedure No. 577.

20 The following data presented as Table 2 demonstrate that active recombinant AMY may be successfully extracted from the interstitial fluid of plant leaves using the present method. The IF method results in a recovery of 34% of the total AMY activity of the leaf at a 27-fold enrichment relative to an extract obtained by homogenization (H). The AMY production results may be improved by optimizing the time post-inoculation with the viral
25 vector and minimizing the contaminating viral coat protein from the intercellular fraction.

EXAMPLE 3Extraction of Glucocerebrosidase protein

Glucocerebrosidase (GCB), either derived from human placental tissue or a

recombinant form from Chinese hamster ovary cells (CHO), is presently used in an effective but costly treatment of the heritable metabolic storage disorder known as Gaucher disease.

We combined a dual promoter from Cauliflower Mosaic Virus (35S), a translational enhancer from Tobacco Etch Virus and a polyadenylation region from the nopaline synthetase gene of *Agrobacterium tumefaciens* with the native human GCB cDNA to create plasmid pBSG638. These expression elements are widely used to provide the highest possible constitutive expression of nuclear-encoded genes in plants.

Using a standard *Agrobacterium*-mediated transformation method, we regenerated 93 independent kanamycin-resistant transformants from leaf discs of four different tobacco cultivars (the TO generation). In Western blots of total protein extracts, cross-reacting antigen was detected in 46 of these TO individuals with antibody raised against human glucocerebrosidase. Specificity of the plant-expressed recombinant enzyme was confirmed by hydrolysis of ¹⁴C-radiolabeled glucosylceramide. According to these expression results the rGCB positive transformants were ranked into moderate (A), low (B) and negligible (C) activity groups.

We also found reaction conditions to preferentially inhibit rGCB enzyme activity in the presence of plant glucosidases using the suicide substrate conduritol B-epoxide (CBE). Total glucosidase activity, and rGCB activity were measured by hydrolysis of the fluorescent substrate 4-methylumbelliferyl glucopyranoside (4-MUG) with and without CBE. Leaves from transgenic plants were removed at the petiole and dissected down the midrib into two equal halves to make a convenient size leaf material for the equipment used. To obtain a total cellular homogenate, one group of half-leaves was ground in the presence of 4 volumes of detergent extraction buffer (100 mM potassium phosphate pH 6.5 mM EDTA, 10 mM, α -mercaptoethanol and 0.5% w/v sodium taurocholate) with a mortar and pestle after freezing the tissue in liquid nitrogen. One of ordinary skill in the art could readily envision a buffer wherein the EDTA is substituted with other chelaters such as EGTA and citrate. One of ordinary skill in the art could readily envision a buffer solution wherein α -mercapto ethanol

Table 2

Sample	Fresh Weight (gr)	Total Volume (ml)	Protein Conc. (mg/ml)	Total Protein (mg)	Protein Yield (mg/gr)	Rprotein Conc. (U/ml)	Total RProtein (U)	2Specific Yield (U/gr)	3RProtein Yield (U/gr)	%Recovery RProtein In IF	X-Fold Purification
Amylase/IF	1.76	1.8	0.22	0.39	0.22	0.319	0.57	0.33	1.463	34	27
Amylase/H	1.76	5.8	5.40	31.33	17.80	0.290	1.68	0.96	0.054	ND	1

16 5

IF = Interstitial fluid extraction

H = homogenization extraction

10

ND = Not determined

is substituted by other antioxidants including ascorbate, sodium metabisulfite and dithiothreitol. One of ordinary skill in the art can readily envision that a buffer solution could substitute the sodium taurocholate with other detergents including: SDS, Tritons, Tween@s, phospholipids, bile salts, sodium deoxycholate and sodium lauryl sulfate. To recover the interstitial fluid (IF), the same enzyme extraction buffer was infiltrated into the opposing group of half-leaves by submerging the tissue and pumping a moderate vacuum (500 mm Hg). After draining off excess buffer, the undisrupted half-leaves were rolled gently in parafilm, placed in disposable tubes and the interstitial fluid (IF) was collected by low-speed centrifugation (1,000 x G) for about 15 minutes. The weight of buffer recovered from the infiltrated leaf tissue is recorded and varies from approximately one-half to equal the original weight of the leaf. Using the suicide substrate, conduritol β -epoxide (CBE), inhibition of recombinant glucocerebrosidase (rGCB) activity in the presence of plant glucosidases was achieved. Enzyme activity was measured at 37°C in a reaction mixture containing 5 mM methylumbelliferyl β -D glucoside, 0.1 M potassium phosphate, 0.15% Triton-X100, 0.125% sodium taurocholate, 0.1% bovine serum albumin, pH 5.9 with and without CBE. Total glucosidase activity and rGCB activity were measured by hydrolysis of the fluorescent substrate 4-methylumbelliferyl glucopyranoside. One unit of activity is defined as the amount of enzyme required to catalyze the hydrolysis of 1 nmol of substrate per hour. Total protein was determined using the Bio-Rad Protein Assay® based on the method of Bradford (Bradford, M., *Anal. Biochem.* 72:248; 1976)

The following data presented as Table 3 demonstrate that active recombinant GCB may be successfully extracted from the interstitial fluid of plant leaves using the present method. The IF method results in a recovery of 22% of the total GCB activity of the leaf at a 18-fold enrichment relative to an extract obtained by homogenization.

EXAMPLE 4

Extraction of Avian Interferon type II (gamma)

Avian (chicken) interferon type II (gamma) has been expressed and active enzyme

extracted from the interstitial space of Nicotiana benthamiana and Nicotiana tabacum. The interferon could be efficiently extracted from plants grown in the field or greenhouse using either gram (bench-scale extraction) or Kg (pilot-scale extraction) quantities of plant tissue.

Actively growing *N. benthamiana* or *N. tabacum* were inoculated with either
5 infectious transcripts or virion of a recombinant plant construct as described by Donson *et al.*,
supra, harboring the chicken interferon gamma gene. Avian interferon was extracted from
systemically infected leaves 10 days to 3 weeks post inoculation.

EXAMPLE 4a

10 For bench-scale extractions, systemically infected leaves (3-80 grams) were detached from
the plant at the leaf base, weighed, and placed in an appropriate sized beaker. The leaf
material was completely covered with a buffered solution (100 mM Tris-HCl pH 7.5 buffer
containing 5 mM MgCl₂ and 2 mM EDTA). The immersed leaves were covered with a
Nalgene vacuum jar and a vacuum was pumped (720 mm Hg) and held for 2 minutes and
15 then rapidly released. This vacuum infiltration was then repeated for a total of two cycles.
Following the vacuum infiltrations, the leaves were removed from the beaker and surface
buffer was removed from the leaves' surface by blotting between absorbent paper. Leaves
were placed in a 250 ml bottle, containing a supported mesh which allows for the separation
and recovery of the IF from the leaf material. The interstitial fluid (IF) was recovered from
20 the vacuum infiltrated leaves by centrifugation (3,000 x G, 15 minutes).

EXAMPLE 4b

For pilot-scale extractions, systemically infected leaves from field grown plants were stripped
off the stalks by hand and weighed. Five kg of leaves were placed into polyester mesh bags
25 (Filtru-Spec®, 12-2-1053), and two x 5 kg bags of leaves were placed into a metal basket.
The metal basket containing the leaf material was placed in a 200 L Mueller®
vacuum tank containing ~ 50 liters of buffered solution (100 mM Tris-HCl pH 7.5 buffer

Table 3

Sample	Fresh Weight (g)	Total Volume (ml)	Protein Conc. (mg/ml)	Total Protein (mg)	Protein Yield (mg/gr)	Rprotein Conc. (U/ml)	Total Rprotein (U)	Specific Yield (U/g)	Rprotein Yield (U/g)	%Recovery Rprotein In IF	X-Fold Purification
GCB/IF	2.48	1.9	0.24	0.45	0.18	720	1368	552	3007	22	18
GCB/H	2/08	8.1	3.89	31.48	15.13	653	5289	2543	168	ND	1

19

5

IF = Interstitial fluid extraction

H = homogenization extraction

ND = Not determined

containing 5 mM MgCl₂ and 2 mM EDTA). A 70 lb. stainless steel plate was placed over the leaves/bags to assure complete immersion. A vacuum was pumped to 27 inches Hg and held for 1 minute and then rapidly released. This vacuum infiltration was then repeated for a total of two cycles. Following the vacuum infiltrations, the leaves and basket were removed from the vacuum tank. The bags containing the vacuum infiltrated leaves were allowed to gravity drain surface buffer for ~10 minutes, prior to centrifugation. The interstitial fluid (IF) was recovered from the vacuum infiltrated leaves by centrifugation (1,800 x G, 30 minutes) using a Heine® basket centrifuge (bowl dimensions, 28.0 inch diameter x 16.5 inches). Collected IF was filtered through a 25 µm, Rosedale® sock filter and then through a 5 µm, Campbell Waterfilter® cartridge filter and then stored at 4°C, prior to analysis.

The amount of interferon protein in an IF extract was determined by quantitative immunoblotting procedures using specific antisera to avian type II interferon and *E. coli* produced type II interferon in known quantities as standard. Based on quantitative immunoblotting, and partial purification, we estimate the specific activity of interferon in *N. benthamiana* IF at or near 10⁷ U/mg which is essentially equal to interferon isolated from native sources. Biological activity was determined by the nitrous oxide (NO) release assay as described in Lowenthal, J.W., Digby, M.R. and York, J. J. Production of Interferon-γ by Chicken T Cells, *J. Interferon and Cytokine Res.* (1995) 15:933-938. Specificity of activity was determined by pre-incubation of IF fluid with a neutralizing antibody followed by measuring activity in the NO release assay.

Table 4

Greenhouse:

Plant type	Av. Tissue Amt.	Interferon protein yield ¹	Yield activity ²
<u><i>N. benthamiana</i></u>	3-60 g	1 mg/100g fresh wt	~30,000 U/ml IF
<u><i>N. tabacum</i></u> cv. MD609	20 g	0.1 mg/100g fresh wt	~3,000 U/ml IF
<u><i>Nitabacum</i></u> TI231	20 g	0.1 mg/100g fresh wt	~3,000 U/ml IF

Table 5Field:

Greenhouse Plant type	Av. Tissue Amt.	Interferon protein yield ¹	Yield activity ²
<u>N. tabacum</u> cv TI264	80 g	0.05 mg/100 g fresh wt	ND*
<u>N. tabacum</u> cv TI264	10 kg	0.01 mg/100 g fresh wt	~200 U/ml IF**

¹Interferon protein yield was estimated by quantitative immunoblotting.

²Interferon activity was determined by the NO release assay as described by Lowenthal *et al.* supra

*Not determined

5

** Activity estimates contained some lack of specificity (activity not neutralized by specific antibody) in NO release assay.

10 **EXAMPLE 5**

Extraction of mouse scFv protein

Actively growing *N. benthamiana* were inoculated with infectious transcripts of a recombinant plant construct as described by Donson *et al.*, supra, harboring a scFv protein from the 38C13 mouse lymphoma. Mouse 38C13 scFv protein was extracted from systemically
15 infected leaves 11-14 days post inoculation.

Systemically infected leaves (3-80 grams) were detached from the plant at the leaf base, weighed, and placed in an appropriate sized beaker. The leaf material was completely covered with a buffered solution (100 mM Tris-HCl pH 7.5 buffer containing 10 mM MgCl₂ and 2 mM EDTA). The immersed leaves were covered with a Nalgene vacuum jar and a vacuum was
20 pumped to 700 mm Hg, and held for 2 minutes and then rapidly released. This vacuum infiltration was then repeated for a total of two cycles. Following the vacuum infiltrations, the leaves were removed from the beaker and surface buffer was removed from the leaves' surface

by blotting between absorbent paper. The interstitial fluid (IF) was recovered from the vacuum infiltrated leaves by centrifugation (3,000 x G, 15 minutes). Leaves were centrifuged in a 250 ml bottle, containing a supported mesh which allows for the separation and recovery of the IF from the leaf material. The IF fluid containing the scFv protein was filtered through a 0.2 µm membrane and stored at -80°C.

The product and purification of 38C13 scFv protein from plant IF fluid was determined by Western analysis using S1C5, a monoclonal anti-idiotypic antibody which recognizes native 38C13 IgM protein. The S1C5 antibody cross reacted with a 30 KD protein of the expected size of 38C13 scFv and a 60 KD protein, which is the correct size for a spontaneously assembling scFv dimer. No cross reactivity to plant proteins in IF extracts prepared from control infected plants was observed.

The quantity of plant-produced 38C13 scFv protein recovered from IF extracts was measured by S1C5 ELISA. Leaf IF extracts were determined to contain 20-60 µg of 38C13 scFv protein/ ml IF fluid or 11-30 µg of 38C13 scFv protein/ g fresh weight. Since ELISA conditions favor anti-idiotypic recognition in solution, it is concluded that the major fraction of 38C13 scFv isolated from plant IF fluid is soluble and properly folded.

EXAMPLE 6

Extraction of secretory immunoglobulin from transgenic tobacco

Leaves from transgenic, SigA-G expressing *N. tabacum* (15 grams), (Science, 268:716, 1995), were detached from the plant at the leaf base, weighed, and placed in an appropriate sized beaker. The leaf material was completely covered with a buffered solution of either 100 mM Tris-Hcl pH 7.5 buffer containing 10 mM MgCl₂, 2 mM EDTA and 14.3 mM 2-mercaptoethanol or 100 mM potassium phosphate, pH6.0, 5 mM EDTA, 10.0 mM 2-mercaptoethanol and 0.5% taurocholic acid). The immersed leaves were covered with a Nalgene® vacuum jar and a vacuum was pumped to 750 mm Hg, and held for 1 minute and then rapidly released. Following the vacuum infiltrations, the leaves were removed from the

beaker and surface buffer was removed from the leaves' surface by blotting between absorbent paper. The interstitial fluid (IF) was recovered from the vacuum infiltrated leaves by centrifugation (1500 x G, 15 minutes). Leaves were centrifuged in a 250 ml bottle, containing a supported mesh which allows for the separation and recovery of the IF from the leaf material.

5 Protein immunoblots of the IF extracts were prepared under reducing conditions. Ig was detected in the immunoblots using goat anti-mouse IgA conjugated to horseradish peroxidase. Approximately 10% of the IgA present in the plant was detected in the IF extracts. There was no visible difference in the quantity of Ig in the IF fractions produced using the different buffers described above. No cross reactivity to plant proteins in IF extracts prepared from control
10 plants was observed.

EXAMPLE 7

Pilot Scale Purification of Glucocerebrosidase from the Intercellular Fluid of Tobacco

MD609 leaf tissue (1-2 kilograms) of transgenic tobacco expressing the lysosomal
15 enzyme glucocerebrosidase was harvested; the mid vein removed and the tissue weighed. Tissue was submerged with 2-4 volumes of buffer (0.1 M KPO₄ buffer, pH 6.0, 5 mM EDTA, 0.5% taurocholic acid, 10 mM 2-mercaptoethanol) using an infiltration vessel that accommodates several kilograms of leaf tissue at one time. A perforated metal plate was placed on top of tissue to weigh down the tissue, and a vacuum was pumped to 620-695 mm Hg for 1-2
20 minutes x 3. The vacuum was released between subsequent applications. Tissue was rotated and the vacuum reapplied to achieve complete infiltration. Multiple applications of the vacuum without isolating the interstitial fluid constitutes a single infiltration procedure. An indication of complete infiltration is a distinct darkening in color of the underside of the leaf tissue. Excess buffer on the tissue was drained. The interstitial fluid was released from the tissue by
25 centrifuging the tissue in a basket rotor (10 in. x 4.25 in., InterTest Equipment Services, San Jose, CA/Biosource Design 25-0611000) at 4200 RPM (2500 x G) for 10 minutes. The interstitial fluid was collected by aspiration (IF-1). Alternatively, the leaf tissue can be re-

infiltrated by placing the leaves back in the infiltration vessel in the same buffer used above and the process repeated (IF-2). The second infiltration does not require as many cycles of vacuum infiltration and vacuum release. Additionally, the buffer may be drained from the infiltration vessel (spent buffer) and pooled with the 1st and 2nd IF fractions. Collectively, IF-1, IF-2 and
5 spent buffer constitutes the IF pool. The volume of interstitial fluid collected from the infiltrated leaf tissue was between 50 – 100% of the leaf tissue by weight depending on the number of infiltrations carried out.

Recombinant GCB was purified by loading the dilute IF (feed stream) directly on a Pharmacia Streamline 25® column containing Phenyl Streamline® resin. Expanded bed
10 chromatography enabled us to capture, clarify and concentrate our protein in one step without the need for centrifugation and/or microfiltration steps. The column was equilibrated and washed until the UV-signal on the recorder returned to baseline with 25 mM citrate, 20% ethylene glycol, pH 5.0; bound enzyme was eluted with 25 mM citrate, 70% ethylene glycol. The eluted material was further purified on a cation exchange resin, SP Big Beads®
15 (Pharmacia), equilibrated in 25 mM citrate, 75 mM NaCl, pH 5.0. GCB was eluted with either a step gradient of 25 mM citrate, 0.5 M NaCl, 10% ethylene glycol, pH 5.0 or a linear gradient of 75 mM – 0.4 M NaCl in 25 mM citrate, pH 5.0. All chromatography steps were carried out at room temperature.

Using the suicide substrate, conduritol β -epoxide (CBE), inhibition of recombinant
20 glucocerebrosidase (rGCB) activity in the presence of plant glucosidases was achieved. Enzyme activity was measured at 37°C in a reaction mixture containing 5 mM methylumbelliferyl β -D glucoside, 0.1 M Potassium Phosphate, 0.15% Triton-X100, 0.125% sodium taurocholate, 0.1% bovine serum albumin, pH 5.9 with and without CBE. Total glucosidase activity and rGCB activity were measured by hydrolysis of the fluorescent substrate
25 4-methylumbelliferyl glucopyranoside. One unit of activity is defined as the amount of enzyme required to catalyze the hydrolysis of 1 nmol of substrate per hour. Total protein was determined using the Bio-Rad Protein Assay based on the method of Bradford (Bradford, M.

Anal. Biochem. 72:248; 1976).

Typically from 1 kilogram of leaves where IF-1 alone was collected we obtained 4 million units of GCB at a specific activity of 20,000. The Units /kg increased to 6 million with a lower specific activity of 10,000 when IF Pool was collected (IF-1, IF-2 and spent buffer).

5 Table 6 below contains data that is representative of several experiments.

EXAMPLE 8

Ultrafiltration/Concentration of Intercellular Fluid from Tobacco Expressing

Glucocerebrosidase

10 2.3 kilograms of MD609 leaf tissue from transgenic tobacco expressing the lysosomal enzyme glucocerebrosidase was harvested, the mid vein removed and the tissue weighed. Tissue was submerged with 2-4 volumes of buffer (0.1 M KPO₄ buffer, pH 6.0, 5 mM EDTA, 0.5% taurocholic acid, 10 mM 2-mercaptoethanol) in an infiltration vessel that accommodates several kilograms of leaf tissue at one time. A perforated metal plate was placed on top of tissue to
15 weigh down the tissue. A vacuum was pumped to 620-695 mm Hg for 1-2 minutes x 3. The vacuum was released between subsequent applications. Tissue was rotated and the vacuum reapplied to achieve complete infiltration. Excess buffer on the tissue was drained. The interstitial fluid was released from the tissue by centrifuging the tissue in a basket rotor (10 in. x 4.25 in., Intertest Equipment Services, San Jose, CA/Biosource Design 25-0611000) at 4200
20 RPM (2500 x G) for 10 minutes. The interstitial fluid was collected by aspiration (IF-1). The leaf tissue was re-infiltrated by placing the leaves back in the infiltration vessel in the same buffer used above and the process repeated (IF-2). The buffer was drained from the infiltration vessel (spent buffer) and pooled with the 1st and 2nd IF fractions. Collectively, IF-1, IF-2 and spent buffer constitutes the IF pool. The IF pool was filtered through Miracloth and
25 then concentrated 6 fold by passing the IF pool through a 1 sq. ft. spiral membrane (30K molecular weight cutoff) using an Amicon RA 2000® concentrator equipped with an LP-1 pump.

Table 6

GCB-Lab Pilot Scale IF Process

Sample/ Fraction#	Fresh Weight (Grams)	Total Vol (ml)	Protein Conc. (mg/ml)	Total Protein (mg)	GCB (mg)	Protein Yield (mg/g)	GCB Conc (U/ml)	Total GCB (Units)	Units/kg Tissue	Sp Activity nmol/hr (U/mg)	%GCB Protein= GCB	Step Recovery (%)	Step Purification fold	Total Recovery (%)	Total Purification fold
IF1	1045	930	0.236	219	2.91	0.21	4,692	4,363,544	4,175,640	19,881	1.33	100	1	100	1
Phenyl Streamline 4/30/97	1045	400	0.065	26	2.47	0.025	9,276	3,710,467	3,550,686	142,710	9.51	85	7.2	85	7.2
IF1,2 & Spent buffer	1027	4020	0.29	1166	4.32	1.135	1,611	6,478,201	6,307,888	10,047	0.67	100	1	100	1
IF1,2 & SB Phenyl SL column load	1027	2330	0.29	676	2.5	0.658	1,611	3,752,778	3,656,064	10,047	0.67	100	1	100	1
Phenyl Streamline eluted material	1027	400	0.078	31	2.36	0.03	8,858	3,543,390	3,450,234	113,570	7.57	94.4	11.3	94.4	11.3
SP Big Beads eluant eluted material	1027	70	0.078	5	1.72	0.005	36,952	2,586,674	2,518,670	473,750	31.58	73	4.2	68.9	47.2

5 IF = interstitial fluid

Using the suicide substrate, conduritol β -epoxide (CBE), inhibition of recombinant glucocerebrosidase (rGCB) activity in the presence of plant glucosidases was achieved. Enzyme activity was measured at 37°C in a reaction mixture containing 5 mM methylumbelliferyl β -D glucoside, 0.1 M potassium phosphate, 0.15% Triton-X100, 0.125% sodium taurocholate, 0.1% bovine serum albumin, pH 5.9 with and without CBE. Total glucosidase activity and rGCB activity were measured by hydrolysis of the fluorescent substrate 4-methylumbelliferyl glucopyranoside. One unit of activity is defined as the amount of enzyme required to catalyze the hydrolysis of 1 nmol of substrate per hour. Total protein was determined using the Bio-Rad Protein Assay® based on the method of Bradford (Bradford, M. *Anal. Biochem.* 72:248; 1976). See Table 7 below.

EXAMPLE 9

Pilot Scale Purification of Glucocerebrosidase from the Intercellular Fluid of Field Grown Tobacco

100 kilograms of MD609 leaf tissue from transgenic tobacco expressing the lysosomal enzyme glucocerebrosidase was harvested from the field each day for a period of two weeks. The tissue was stripped off the stalks by hand and weighed. Five kilograms of leaves were placed into polyester bags (Filtru-Spec®, 12-2-1053) and four x 5 kg bags of leaves were placed into a metal basket. The metal basket containing the leaf material was placed in a 200 liter Mueller vacuum tank containing ~ 100 liters of buffered solution (0.1 KPO₄ buffer, pH 6.0, 5 mM EDTA, 0.5% taurocholic acid, 10 mM 2-mercaptoethanol). A 70 lb. stainless steel plate was placed over the leaves/bags to assure complete immersion. A vacuum was pumped to 695 mm Hg, held for 1 minute and then rapidly released. This vacuum infiltration was repeated for a total of two cycles. Multiple applications of the vacuum without isolating the interstitial fluid constitutes a single infiltration procedure. An indication of complete infiltration is a distinct darkening in color of the underside of the leaf tissue. Following the vacuum infiltrations, the leaves and basket were removed from the vacuum tank. The bags containing the vacuum infiltrated leaves were allowed to gravity drain surface buffer for ~ 10 minutes, prior to centrifugation. The interstitial fluid (IF) was recovered from the vacuum

Table 7

GCB UF Experiment

Sample/ Fraction#	Fresh Weight (Grams)	Total Vol (ml)	Protein Conc. (mg/ml)	Total Protein (mg)	GCB (mg)	Protein Yield (mg/g)	GCB Conc (U/ml)	Total GCB (Units)	Units/kg Tissue	Sp Activity nmol/hr ((U/mg)	%GCB % of total Protein= GCB	Step Recovery (%)	Step Purification fold	Total Recovery (%)	Total Purification fold
IF	1,102	5,874	0.223	1310	6.5	1.189	1,659	9,745,470	8,843,439	7,440	0.5	100	1	100	1
30 K Concentrate	1,102	875	0.593	519	6.39	0.471	10,947	9,578,575	8,691,992	18,460	1.23	98.3	2.5	98.3	2.5

28

5

IF = interstitial fluid

infiltrated leaves by centrifugation (1,800 x G, 30 minutes) using a Heine® basket centrifuge (bowl dimensions, 28.0 inches diameter x 16.5 inches).

Collected IF was filtered through a 50 μ cartridge filter and then stored at 4°C, until the entire 100 kilograms of tissue was infiltrated. This process was repeated with the next set of
5 four 5 kg bags (5 x 20 kg cycles total) until all the tissue was infiltrated. Additional buffer was added during each infiltration cycle to completely immerse the tissue. Alternatively, the leaf tissue can be re-infiltrated by placing the leaves back in the infiltration vessel in the same buffer used above and the process repeated (IF-2). Additionally, the buffer may be drained from the infiltration vessel (spent buffer) and may be pooled with the 1st and 2nd IF fractions.

10 Collectively, IF-1, IF-2 and spent buffer constitutes the IF pool. The volume of interstitial fluid collected from the infiltrated leaf tissue was between 42-170% of the leaf tissue by weight depending on the number of infiltrations carried out.

Recombinant GCB was purified by loading the dilute interstitial fluid (feed stream) directly on a Pharmacia Streamline 200® column containing Phenyl Streamline® resin.

15 Expanded bed chromatography enabled us to capture, clarify and concentrate our protein in one step without the need for centrifugation and/or microfiltration steps. The column was equilibrated and washed until the UV-signal on the recorder returned to baseline with 25 mM citrate, 20% ethylene glycol, pH 5.0; the bound enzyme was eluted with 25 mM citrate, 70% ethylene glycol. The eluted material was sterile filtered by passing the eluted material through a
20 1 sq. ft. 0.8 μ m Sartoclean GF® capsule followed by a 1 sq. ft. 0.2 μ m Sartobran P® sterile filter (Sartorius, Corp.) and stored at 4°C until the next chromatography step. The eluted material from 4-5 days of Phenyl Streamline® chromatography runs was pooled together and further purified on a cation exchange resin, SP Big Beads® (Pharmacia), equilibrated in 25 mM citrate, 75 mM NaCl, pH 5.0. GCB was eluted with a step gradient of 25 mM citrate, 0.4 M NaCl, 10
25 % ethylene glycol, pH 5.0. All chromatography steps were carried out at room temperature. The eluted material was sterile filtered by passing the eluted material through a 1 sq. ft. 0.8 μ m Sartoclean GF® capsule followed by a 1 sq. ft. 0.2 μ m Sartobran P® sterile filter (Sartorius, Corp.) and stored at 4°C.

Using the suicide substrate, conduritol β -epoxide (CBE), inhibition of recombinant glucocerebrosidase (rGCB) activity in the presence of plant glucosidases was achieved. Enzyme activity was measured at 37°C in a reaction mixture containing 5 mM methylumbelliferyl β -D glucoside, 0.1 M Potassium Phosphate, 0.15% Triton-X100, 0.125% sodium taurocholate, 0.1% bovine serum albumin, pH 5.9 with and without CBE. Total glucosidase activity and rGCB activity were measured by hydrolysis of the fluorescent substrate 4-methylumbelliferyl glucopyranoside. Total protein was determined using the Bio-Rad Protein Assay® based on the method of Bradford (Bradford, M. *Anal. Biochem.* 72:248; 1976).

Typically from 1 kilogram of field grown tobacco, expressing GCB, where IF-1 alone was collected we obtained 435,000 units of GCB at a specific activity of 2,745 units. The Unit/kg increased to 755,000 with a specific activity of 3,400 when IF Pool was collected (IF-1, IF-2 and spent buffer).

Table 8 below contains data that is representative of one week of experiments.

15 EXAMPLE 10

Chopped Tissue Experiment

An experiment was carried out where 100 kilograms of MD609 leaf tissue of transgenic tobacco expressing the lysosomal enzyme glucocerebrosidase was harvested off the stalks by hand, weighed and chopped into small pieces to increase the surface area for buffer infiltration. Five kilograms of leaves were placed into polyester bags (Filtru-Spec®, 12-2-1053) and four x 5 kg bags of leaves were placed into a metal basket. The metal basket containing the leaf material was placed in a 200 liter Mueller® vacuum tank containing ~ 100 liters of buffered solution (0.1 KPO₄ buffer, pH 6.0, 5 mM EDTA, 0.5% taurocholic acid, 10 mM 2-mercaptoethanol). A 70 lb. stainless steel plate was placed over the leaves/bags to assure complete immersion. A vacuum was pulled 695 mm Hg, held for 1 minute and then rapidly released. This vacuum infiltration was repeated for a total of two cycles. Following the vacuum infiltrations, the leaves and basket were removed from the vacuum tank. The bags containing the vacuum infiltrated

Table 8

GCB Field Test Pilot Scale-P.SL

Sample/ Fraction#	Fresh Weight (Grams)	Total Vol (ml)	Protein Conc. (mg/ml)	Total Protein (Mg)	GCB (mg)	Protein Yield (mg/g)	GCB Conc U/ml	Total GCB (Units)	Units/kg Tissue	Sp Activity nmol/hr ((U)/mg)	%GCB % of total Protein= GCB	Step Recovery (%)	Step Purification fold	Total Recovery (%)	Total Purification fold
IF1, 2&SB-Day 1	100,000.00	164,500	0.12	19740	49.24	0.197	449	73,860,500	738,605	3,742	0.25	100	1	100	1
Phenyl Streamline eluted material	100,000.00	37,600	0.04	1504	5.84	0.015	233	8,760,800	87,608	5,825	0.39	11.9	1.6	11.9	1.6
IF1,2&SB-Day 2	100,000.00	171,000	0.144	24624	51.41	0.246	451	77,121,000	77,121,000	3,132	0.21	100	1	100	1
Phenyl Streamline eluted material	100,000.00	42,500	0.036	1530	8.67	0.015	306	13,005,000	13,005,000	8,500	0.57	16.9	2.7	16.9	2.7
IF1,2-Day 3	100,000.00	95,500	0.547	52239	39.16	0.522	615	58,732,500	58,732,500	1,124	0.07	100	1	100	1
Phenyl Streamline eluted material	100,000.00	34,000	0.059	2006	22.05	0.02	973	33,082,000	33,082,000	16,492	1.1	56.3	14.7	56.3	14.7
IF1-Day 4	100,000.00	50,000	0.273	13650	20.23	0.137	607	30,350,000	30,350,000	2,223	0.15	100	1	100	1
Phenyl Streamline eluted material	100,000.00	35,800	0.046	1647	14.77	0.016	619	22,160,200	22,160,200	13,457	0.9	73	6.1	73	6.1
IF1-Day 5	100,000.00	86,000	0.348	29928	35.03	0.299	611	52,546,000	52,546,000	1,756	0.12	100	1	100	1
Phenyl Streamline eluted material	100,000.00	40,700	0.065	2646	19.73	0.226	727	29,588,900	29,588,900	11,185	0.75	56.3	6.4	56.3	6.4
SP Big Beads-5 days of PSL runs	500,000.00	191,650	0.053	10157	62.08	0.02	486	93,113,911	93,113,911	9,167	0.61	100	1	100	1
SP Big Beads eluted material	500,000.00	17,000	0.043	731	48.35	0.001	4,266	72,529,928	72,529,928	99,220	6.61	77.9	10.8	77.9	10.8

31

leaves were allowed to gravity drain surface buffer for ~ 10 minutes, prior to centrifugation. The interstitial fluid (IF) was recovered from the vacuum infiltrated leaves by centrifugation (1,800 x G, 30 minutes) using a Heine® basket centrifuge (bowl dimensions, 28.0 inches diameter x 16.5 inches). Collected IF was filtered through a 50 µ cartridge filter and then stored at 4°C, until the entire 100 kilograms of tissue was infiltrated. This process was repeated with the next set of four 5 kg bags (5 cycles x 20 kg cycles total) until all the tissue was infiltrated. Additional buffer was added during each infiltration cycle to completely immerse the tissue. In order to evaluate how much enzyme was recovered in the interstitial fluid, the tissue from which the interstitial fluid was isolated was then homogenized in a Waring® blender with 4 volumes of the same infiltration buffer as above, centrifuged and the supernatant assayed for enzyme activity.

Recombinant GCB was purified by loading the dilute interstitial fluid (feed stream) directly on a Pharmacia Streamline 200® column containing Phenyl Streamline® resin. The column was equilibrated and washed until UV-signal on recorder returned to baseline with 25 mM citrate, 20% ethylene glycol, pH 5.0 and then eluted with 25 mM citrate, 70% ethylene glycol. All chromatography steps were carried out at room temperature. Table 9 below contains data from the chops experiment.

EXAMPLE 11

Pilot Scale Purification of Alpha Galactosidase from the Intercellular Fluid of *Nicotiana benthamiana*

Actively growing *Nicotiana benthamiana* plants were inoculated with infectious transcripts of a recombinant plant viral construct containing the lysosomal enzyme alpha galactosidase gene wherein the α -galactosidase gene contains a carboxy-terminal modification to the nucleotide sequence to enable secretion to the interstitial space. Systemically infected leaf tissue (1-2 kilograms) was harvested from *Nicotiana benthamiana* expressing alpha galactosidase 14 days post inoculation. The tissue was weighed and submerged with 2-4

Table 9

GCB Field Test Chops

Sample/ Fraction#	Fresh Weight (Grams)	Total Vol (ml)	Protein Conc. (mg/ml)	Total Protein (mg)	GCB (mg)	Protein Yield (mg/g)	GCB Conc (U/ml)	Total GCB (Units)	Units/kg Tissue	Sp Activity nmol/hr ((U)/mg)	%GCB % of total Protein= GCB	Step Recovery (%)	Step Purification fold	Total Recovery (%)	Total Purification fold
IFI/Chops	100,000.00	56,000	0.678	37946	10.42	0.379	279	15,624,000	156,240	412	0.03	100	1	100	1
Phenyl Streamline eluded material	100,000.00	30,000	0.072	2147	9.38	0.021	469	14,070,000	140,700	6,553	0.44	90.1	15.9	90.1	15.9
Tissue Homogenate	100,000.00	56,000	ND	ND	15.08	0	404	22,621,081	226,211	ND	ND	ND	ND	ND	ND

33

5 ND = not determined

volumes of buffer (25 mM bis tris propane buffer, pH 6.0, 5 mM EDTA, 0.1 M NaCl, 10 mM 2-mercaptoethanol) in an infiltration vessel that can accommodate several kilograms of leaf tissue at one time. A perforated metal plate was placed on top of tissue to weigh down the tissue. A vacuum was pumped to 620-695 mm Hg for 30 seconds and then quickly released.

5 The tissue was rotated and the vacuum reapplied to achieve complete infiltration which was confirmed by a distinct darkening in color of the underside of the leaf tissue. Excess buffer on the tissue was drained. The interstitial fluid was released from the tissue by centrifuging the tissue in a basket rotor (10 in. x 4.25 in. Depth, InterTest Equipment Services, San Jose, CA/Biosource Design 25-0611000) at 3800 RPM (2100 x G) for 10-15 minutes. The interstitial
10 fluid was collected by aspiration. In some instances only infected leaf tissue was harvested. Alternatively, petioles and stems have been harvested along with the leaf tissue for infiltration. The mid vein was not removed from the tissue prior to infiltration.

Alpha galactosidase was purified by loading the dilute intercellular (feed stream) directly onto a Pharmacia Streamline 25® column containing Butyl Streamline® resin. Expanded bed
15 chromatography enabled the capture, clarification and concentration of the protein in one step without the need for centrifugation and/or microfiltration steps. The column was equilibrated and washed until UV-signal on recorder returned to baseline with 25 mM bis tris propane, pH 6.0 20% (NH₄)₂SO₄ and then eluted with 25 mM bis tris propane, pH 6.0. The eluted material was further purified on hydroxyapatite equilibrated with 1 mM NaPO₄ buffer, 5% glycerol, pH
20 6.0 and eluted with either a 1-250 mM NaPO₄ buffer, 5% glycerol, pH 6.0 linear gradient or a step gradient. All chromatography steps were carried out at room temperature.

Alpha galactosidase activity was measured by hydrolysis of the fluorescent substrate 4-methylumbelliferyl α-D galactopyranoside. Enzyme activity was measured at 37°C in a reaction mixture containing 5 mM methylumbelliferyl α-D galactopyranoside, 0.1 M potassium
25 phosphate, 0.15% Triton-X100®, 0.125% sodium taurocholate, 0.1% bovine serum albumin, pH 5.9. Total protein was determined using the Bio-Rad Protein Assay® based on the method of Bradford (Bradford, M. *Anal. Biochem.* 72:248; 1976).

From 1 kilogram of leaves, we typically obtain between 140 - 160 million units of alpha

galactosidase at a specific activity of 800,000 units following a single infiltration procedure (IF-1).

Table 10 below contains data that is representative of several experiments.

5 **EXAMPLE 12**

Pilot Scale Purification of Glucocerebrosidase from the Leaf Interstitial Fluid and of Recombinant Virus from the Leaf Homogenate of Field Grown Tobacco

Transgenic tobacco (MD609) expressing the lysosomal enzyme glucocerebrosidase was mechanically inoculated with a tobacco mosaic virus derivative containing a coat protein loop fusion, TMV291, (Turpen, *et.al.*, 1995, *Bio/Technology* 13:23-57). A total of 100 kg of transgenic, transfected leaf tissue was harvested from the field, five weeks post inoculation. The tissue was stripped off the stalks by hand and weighed. Five kilograms of leaves were placed into polyester bags (Filtru-Spec®, 12-2-1053) and four x 5 kg bags of leaves were placed into a metal basket. The metal basket containing the leaf material was placed in a 200 liter Mueller® vacuum tank containing ~ 100 liters of buffered solution (0.1 KPO₄ buffer, pH 6.0, 5 mM EDTA, 0.5% taurocholic acid, 10 mM 2-mercaptoethanol). A 70 lb. stainless steel plate was placed over the leaves/bags to assure complete immersion. A vacuum was pumped to 695 mm Hg, held for 1 minute and then rapidly released. This vacuum infiltration was repeated for a total of two cycles. Multiple applications of the vacuum without isolating the interstitial fluid constitutes a single infiltration procedure. An indication of complete infiltration is a distinct darkening in color of the underside of the leaf tissue. Following the vacuum infiltrations, the leaves and basket were removed from the vacuum tank. The bags containing the vacuum infiltrated leaves were allowed to gravity drain surface buffer for ~ 10 minutes, prior to centrifugation. The interstitial fluid (IF) was recovered from the vacuum infiltrated leaves by centrifugation (1,800 x G, 30 minutes) using a Heine® basket centrifuge (bowl dimensions, 28.0 inches diameter x 16.5 inches). Collected IF was filtered through a 50 µ cartridge filter and then

Table 10

Pilot Scale alpha gal

Sample/ Fraction#	Fresh Weight (Grams)	Total Vol (ml)	Protein Conc. (mg/ml)	Total Protein (mg)	Gal (mg)	Protein Yield (mg/g)	Gal Conc (U/ml)	Total Gal (Units)	Units/kg tissue	Sp Activity Nmol/hr ((U/mg)	%Gal % of total Protein= Gal	Step Recovery (%)	Step Purification fold	Total Recovery (%)	Total Purification fold
IF	2026	1,450	0.236	342	74.5	0.169	226,201	327,992,085	161,891,454	958,481	21.78	100	1	100	1
Butyl Streamline eluted material	2026	300	0.392	118	74	0.058	1,085,873	325,761,839	160,790,641	2,770,084	62.96	99.3	2.9	99.3	2.9
Hydroxyapatite eluted material	2026	470	0.076	36	54.2	0.018	507,640	238,590,619	117,764,373	6,679,469	151.81	73.2	2.4	72.7	7

IF = interstitial fluid extraction

stored at 4°C, until the entire 100 kilograms of tissue was infiltrated. This process was repeated with the next set of four 5 kg bags (5 cycles x 20 kg total) until all the tissue was infiltrated. Additional buffer was added during each infiltration cycle to completely immerse the tissue.

5 Recombinant GCB was purified by loading the dilute intercellular (feed stream) directly on a Pharmacia Streamline 200® column containing Phenyl Streamline® resin. Expanded bed chromatography enabled the capture, clarification and concentration the protein in one step without the need for centrifugation and/or microfiltration steps. The column was equilibrated and washed until the UV-signal on the recorder returned to baseline with 25 mM citrate, 20%
10 ethylene glycol, pH 5.0; the bound enzyme was eluted with 25 mM citrate, 70% ethylene glycol. The eluted material was sterile filtered by passing the eluted material through a 1 sq. ft. 0.8 µm Sartoclean GF® capsule followed by a 1 sq. ft. 0.2 µm Sartobran P® sterile filter (Sartorius, Corp.) and stored at 4°C until the next chromatography step. The eluted material from 4-5 days of Phenyl Streamline® chromatography runs was pooled together and further purified on a
15 cation exchange resin, SP Big Beads® (Pharmacia), equilibrated in 25 mM citrate, 75 mM NaCl, pH 5.0. GCB was eluted with a step gradient of 25 mM citrate, 0.4 M NaCl, 10 % ethylene glycol, pH 5.0. All chromatography steps were carried out at room temperature. The eluted material was sterile filtered by passing the eluted material through a 1 sq. ft. 0.8 µm Sartoclean GF® capsule followed by a 1 sq. ft. 0.2 µm Sartobran P® sterile filter (Sartorius,
20 Corp.) and stored at 4°C.

Using the suicide substrate, conduritol β-epoxide (CBE), inhibition of recombinant glucocerebrosidase (rGCB) activity in the presence of plant glucosidases was achieved. Enzyme activity was measured at 37°C in a reaction mixture containing 5 mM methylumbelliferyl β-D glucoside, 0.1 M potassium phosphate, 0.15% Triton-X100®, 0.125%
25 sodium taurocholate, 0.1% bovine serum albumin, pH 5.9 with and without CBE. Total glucosidase activity and rGCB activity were measured by hydrolysis of the fluorescent substrate 4-methylumbelliferyl glucopyranoside. Total protein was determined using the Bio-Rad Protein Assay® based on the method of Bradford (Bradford, M. *Anal. Biochem.* 72:248 (1976)).

The quantity remaining of virus present in IF extracted leaf tissue was determined using homogenization and polyethylene glycol precipitation methods. In addition, the amount of virus present in the pooled, interstitial fluid was determined by direct polyethylene glycol precipitation. Final virus yields from precipitated samples was determined spectrophotometrically by absorbance at 260 nm. (see Table 11)

Table 11

Sample	Virus Titer
Pooled IF	0.004 mg virus/g fresh weight, 0.010 mg virus/ml IF
Homogenized leaf tissue following IF Extraction	0.206 mg virus/g fresh weight

Table 12 contains the GCB recovery data from TMV transfected plant tissue.

This example demonstrates the ability to extract two different products from the same leaf tissue based upon extraction procedures that specifically target products localized in the apoplast and cytosol.

While the invention of this patent application is disclosed by reference to the details of preferred embodiments of the invention, it is to be understood that this disclosure is intended in an illustrative, rather than limiting, sense. It is contemplated that modifications will readily occur to those skilled in the art, within the spirit of the invention and the scope of the appended claims. It is further understood that the instant invention applies to all proteins produced or capable of being recombinantly produced in plants, and is clearly not limited to those proteins specifically described herein.

EXAMPLE 13

Large Scale Centrifugation of IF Fractions

The following example illustrates a scale-up procedure for the production of IF extract

Table 12**GCB Recovery From TMV Transfected Plants**

Sample/ Fraction#	Fresh Weight (Grams)	Total Vol (ml)	Protein Conc. (mg/ml)	Total Protein (mg)	GCB (mg)	Protein Yield (Mg/g)	GCB Conc (U/ml)	Total GCB (Units)	Units/kg tissue	Sp Activity nmol/hr ((U)/mg)	%GCB % of total Protein	Step Recovery (%)	Step Purification fold	Total Recovery (%)	Total Purification Fold
IFi/Virus	100,000	40,000	0.383	15320	18.7	0.153	701	28,055,851	280,559	1,831	0.12	100	1	100	1
Phenyl Streamline eluted material	100,000	25,000	0.024	600	6.66	0.006	400	9,990,926	99,909	16,652	1.11	35.6	9.1	35.6	9.1

using a discontinuous batch method that will produce a constant stream of IF extract to downstream processing. This procedure consists of the following elements:

1. Automated Whole Leaf Harvesting
2. Large Scale Continuous Infiltration
- 5 3. Large Scale Basket Centrifugation

There are at least two full-scale, whole leaf harvester designs available. One has been developed by R.J. Reynolds Company and has been used at their Avoca facility in North Carolina. The other harvester has been developed by University of Kentucky, Agricultural Engineering department and has been demonstrated for three seasons in Daviess County
10 Kentucky in commercial tobacco fields. These harvesters have shown the capability to cut intact plants, strip-off whole leaves and separate the leaves and stem tissue at rates over several acres per hour. The leaves will then be transported to the extraction facility in trailers.

The leaves will then be unloaded by mechanical conveyor and continuous weigh belt feeder into the vacuum infiltration system. Two systems have been designed. System 1 (Figure
15 1) is a bulk tank. This tank is constructed for full vacuum and is rotatable at low (less than 50) rpm so that all leaves are immersed in the infiltration medium. A vacuum is created by conventional mechanical vacuum pumps or by a steam ejector to a vacuum equal to 21 inches of water column pressure. The vacuum is then released causing infiltration of the tissue. The vessel is then drained to a secondary tank for buffer reuse and the leaf tissue is discharged from
20 the vessel via an auger in the bottom of the tank to a discharge port and onto a conveyor. This conveyor transports the leaves to the basket centrifuge via a weigh belt. The weigh belt insures that a measured amount of material is added to the centrifuge for each centrifugations cycle. System 2 is a continuous vacuum infiltration system. This system consists of large cylindrical tube that has an internal auger conveyor (Figure 2). The cylinder is placed at an angle. The
25 cylinder is partially filled with the infiltration fluid. The cylinder is under vacuum provided by conventional vacuum pumps or a steam ejector to approximately 21 inches of water column pressure. Leaf tissue is added through a rotary valve that maintains the vacuum as it adds tissue. The leaf tissue is then immersed for a period of time in the buffer as it travels up the tube,

conveyed by the auger. The infiltrated leaves are discharged at the elevated end of the auger through another rotary valve. At this point the vacuum is released. This type of pressure vessel, equipped with rotary valves and an auger transport flight is adapted from a pressure vessel design by Christian Engineering (San Francisco) that is used for continuous cooking of rice and other materials using steam pressure. Once discharged, the leaves are transported to the basket centrifuge via a conveyor equipped with a weigh belt. The weigh belt functions as stated above to insure the proper charge of material for each cycle of the basket centrifuge.

The basket centrifuge is a modification of a basic Sanborn (UPE) design for the vegetable industry for dewatering salad greens after washing. The centrifuge is a basket design with a cone type spindle on the inside of the basket. The basket is a two piece design that accomplishes the separation of the bottom plate from the cylinder via a hydraulic piston. The centrifuge is loaded at very low speed (i.e., low RPM or low G force) via a conveyor that is placed over the center of the basket equipped with the cone spindle. As the material drops from the conveyor it is deflected by the cone evenly upon the side of the perforated basket. When the charge of the leaves is complete the auger stops and the basket is accelerated to 2000-2500 x G for approximately 5-60 min. The IF fluid is recovered from the centrifuge. At the end of the centrifugation the basket is decelerated to a low rpm. The bottom of the basket is separated from the sides (cylinder) by the action of the hydraulic piston. The leaf tissue is discharged to a conveyor, the bottom of the centrifuge is closed and the cycle is repeated. This design requires that a rotor and drive be designed that can be rated for the higher G force. Typically the Sanborn type machines are only rated for 600 to 800 G. It is, however, within normal engineering parameters to construct such an upgraded machine for this unique application.

CONVERSION TABLE

1 mm Hg = $133,322 \times 10^{-3}$ kPa

1 inch = 25,4 mm

1 lb = 454 g

1 ft = 0,305 m

WHAT IS CLAIMED IS:

1. A method for large-scale recovery of a concentrated and active protein of interest from the interstitial fluid of plant tissues comprising the steps of:

- 5 (a) infiltrating a plant tissue with a buffer solution;
- (b) subjecting the plant tissue and buffer solution to a substantially vacuum environment;
- (c) removing the tissue from the buffer solution;
- (d) centrifuging the tissue to remove interstitial fluid; and
- 10 (e) concentrating the protein of interest from the interstitial fluid.

2. The method of claim 1 wherein the tissue is centrifuged by means of a basket centrifuge.

15 3. The method of claim 1 wherein the protein is concentrated by means of ultra filtration.

4. The method of claim 1 wherein the protein is concentrated by means of expanded bed chromatography.

20

5. The method according to claim 1 wherein the plant tissue is selected from the group consisting of: leaves, stems, shoots, flowers, fruit and roots.

25

6. The method according to claim 1 further comprising the step of dissecting the plant leaf substantially along the midrib before infiltrating the plant leaf with a buffer solution.

7. The method of claim 1 wherein the buffer solution is selected from the group consisting of: Citrate, Phosphate and Tris.

30

8. The method of claim 7 wherein the buffer contains detergents selected from the group consisting of sodium laurocholate, SDS, tritons, Tween@s, phospholipids, bile salts, sodium deoxycholate and sodium lauryl sulfate.

9. The method of claim 7 wherein the buffer solution contains chelators selected from the group consisting of: EDTA, EGTA and citrate.

5

10. The method of claim 7, wherein the buffer solution contains antioxidants selected from the group consisting of: α -mercapto ethanol, ascorbate, sodium metabisulfate and dithiothreitol.

10

11. The method of claim 1 wherein the plant leaf and buffer are subjected to a vacuum pressure of 200-760 mm Hg.

12. The method of claim 11 wherein the vacuum pressure is 400 - 760 mm Hg.

15

13. The method of claim 11 wherein the vacuum pressure is 740 - 760 mm Hg.

14. The method of claim 11 wherein the vacuum pressure is 760 mm Hg.

20

15. The method of claim 1 wherein the centrifugation is conducted at a G-force range of 50-5,000 x G.

16. The method of claim 1 wherein the centrifugation is conducted at a G-force range of about 2,000 x G.

25

17. The method of claim 1 wherein the protein of interest is produced in the plant by a recombinant plant viral vector.

18. The method of claim 1 wherein the protein of interest is produced by a transgenic plant.

30

19. The method of claim 1 wherein the protein of interest is produced naturally in the plant.

20. The method of claim 1 further comprising the step of draining or blotting excess buffer from the tissue before centrifuging.

5 21. The method of claim 1 further comprising the step of transferring the tissue from the buffer solution to the centrifuge by means of a discontinuous batch process.

22. The method of claim 1 further comprising the step of substantially purifying a protein of interest from the tissue remaining after the interstitial fluid has been removed by
10 centrifugation.

23. The method of claim 1 wherein the protein is derived from cellular components selected from the group consisting of: the plasma transmembrane, peroxisomes, associated membranes, other organelles, the nucleus, the Golgi apparatus, the cytosol, the rough and
15 smooth endoplasmic reticulum, the mitochondria, the vacuole and the chloroplast.

24. The method of claim 1 wherein the protein of interest is a ribosome inactivating protein.

20 25. The method of claim 1 wherein the protein of interest is a human lysosomal enzyme.

26. The method of claim 1 wherein the protein of interest is an industrial enzyme.

25 27. The method of claim 1 wherein the protein of interest is a cytokine.

28. The method of claim 1 wherein the protein of interest is an antibody or antibody fragment.

30 29. The method of claim 1 wherein the protein of interest is α -galactosidase or an isozyme of α -galactosidase.

30. The method of claim 1 wherein the protein of interest is glucocerebrosidase or an isozyme of glucocerebrosidase.

5 31. The method of claim 1 wherein the protein of interest also comprises a signaling peptide to direct the protein to a specific compartment within the cell.

32. The method of claim 1 wherein more than one type of protein can be simultaneously purified.

10 33. A protein of interest obtained from a plant, wherein the protein is recovered from the interstitial fluid of plant tissues by a method comprising the steps of:

(a) infiltrating a plant tissue with a buffer solution;

15 (b) subjecting the plant tissue and buffer solution to a substantially vacuum environment;

(c) removing the tissue from the buffer solution;

(d) centrifuging the tissue to remove interstitial fluid; and

(e) concentrating the protein of interest from the interstitial fluid.

20 34. The protein of claim 33 wherein the protein is α -galactosidase or an isozyme of α -galactosidase.

25 35. The protein of claim 33 wherein the protein is glucocerebrosidase or an isozyme of glucocerebrosidase.

36. The protein of claim 33 wherein the protein is a ribosome inactivating protein.

37. The protein of claim 33 wherein the protein is human lysosomal enzyme.

30 38. The protein of claim 33 wherein the protein is an industrial enzyme.

39. The protein of claim 33 wherein the protein is a cytokine.

40. The protein of claim 33 wherein the protein is an antibody or antibody fragment.

41. A method according to Claim 1 for large-scale recovery of a concentrated and active protein of interest from the interstitial fluid of plant tissues wherein said plant tissue is
5 infiltrated with said buffer solution by a discontinuous delivery of said buffer to said plant tissue by means of a bulk rotary vacuum infiltration tank.

42. A method according to Claim 1 wherein said infiltration is a continuous infiltration by means of a large cylindrical pressure vessel containing an internal auger with a
10 rotary inlet and a rotary discharge valve.

43. A method according to Claim 2 wherein said basket centrifuge is capable of being loaded or charged at low speed, accelerated to recover IF at about 2000-2500 x g and leaf material is discharged through a split rotor design.

15

44. A method for large-scale recovery of a concentrated biomolecule of interest selected from the group consisting of: lipids, carbohydrates, lipoproteins, polysaccharides, sugars, fatty acids, nucleic acids and polynucleotides, said method comprising the steps of:

- 20
- (a) infiltrating a plant tissue with a buffer solution;
 - (b) subjecting the plant tissue and buffer solution to a substantially vacuum environment;
 - (c) removing the tissue from the buffer solution;
 - (d) centrifuging the tissue to remove interstitial fluid; and
 - (e) concentrating the biomolecule of interest from the interstitial fluid.

25

45. The method of claim 44 wherein the tissue is centrifuged by means of a basket centrifuge.

46. The method of claim 44 wherein the biomolecule of interest is concentrated by
30 means of ultra filtration.

47. The method of claim 44 wherein the biomolecule of interest is concentrated by means of expanded bed chromatography.

48. The method according to claim 44 wherein the plant tissue is selected from the group consisting of: leaves, stems, shoots, flowers, fruit and roots.

5 49. The method according to claim 44 further comprising the step of dissecting the plant leaf substantially along the midrib before infiltrating the plant leaf with a buffer solution.

50. The method of claim 44 wherein the buffer solution is selected from the group consisting of: Citrate, Phosphate and Tris.

10

51. The method of claim 50 wherein the buffer contains detergents selected from the group consisting of sodium laurocholate, SDS, tritons, Tween@s, phospholipids, bile salts, sodium deoxycholate and sodium lauryl sulfate.

15

52. The method of claim 50 wherein the buffer solution contains chelators selected from the group consisting of: EDTA, EGTA and citrate.

20

53. The method of claim 50, wherein the buffer solution contains antioxidants selected from the group consisting of: α -mercapto ethanol, ascorbate, sodium metabisulfate and dithiothreitol.

54. The method of claim 44 wherein the plant leaf and buffer are subjected to a vacuum pressure of 200-760 mm Hg.

25

55. The method of claim 54 wherein the vacuum pressure is 400 - 760 mm Hg.

56. The method of claim 54 wherein the vacuum pressure is 740 - 760 mm Hg.

57. The method of claim 54 wherein the vacuum pressure is 760 mm Hg.

30

58. The method of claim 44 wherein the centrifugation is conducted at a G-force range of 50-5,000 x G.

59. The method of claim 44 wherein the centrifugation is conducted at a G-force range of about 2,000 x G.

5 60. The method of claim 44 wherein the biomolecule of interest is produced in the plant by a recombinant plant viral vector.

61. The method of claim 44 wherein the biomolecule of interest is produced by a transgenic plant.

10

62. The method of claim 44 wherein the biomolecule of interest is produced naturally in the plant.

15

63. The method of claim 44 further comprising the step of draining or blotting excess buffer from the tissue before centrifuging.

64. The method of claim 44 further comprising the step of transferring the tissue from the buffer solution to the centrifuge by means of a discontinuous batch process.

20

65. The method of claim 44 further comprising the step of substantially purifying a biomolecule of interest from the tissue remaining after the interstitial fluid has been removed by centrifugation.

25

66. The method of claim 44 wherein the biomolecule of interest is derived from cellular components selected from the group consisting of: the plasma transmembrane, peroxisomes, associated membranes, other organelles, the nucleus, the Golgi apparatus, the cytosol, the rough and smooth endoplasmic reticulum, the mitochondria, the vacuole and the chloroplast.

30

67. A biomolecule of interest obtained from a plant, wherein the biomolecule is selected from the group consisting of: lipids, carbohydrates, lipoproteins, polysaccharides, sugars, fatty acids, nucleic acids and polynucleotides, and wherein the biomolecule is recovered from the interstitial fluid of plant tissues by a method comprising the steps of:

- (a) infiltrating a plant tissue with a buffer solution;
- (b) subjecting the plant tissue and buffer solution to a substantially vacuum environment;
- (c) removing the tissue from the buffer solution;
- 5 (d) centrifuging the tissue to remove interstitial fluid; and
- (f) concentrating the protein of interest from the interstitial fluid.

68. A method according to Claim 44 for large-scale recovery of a concentrated and active biomolecule of interest from the interstitial fluid of plant tissues wherein said plant tissue
10 is infiltrated with said buffer solution by a discontinuous delivery of said buffer to said plant tissue by means of a bulk rotary vacuum infiltration tank.

69. A method according to Claim 44 wherein said infiltration is a continuous infiltration by means of a large cylindrical pressure vessel containing an internal auger with a
15 rotary inlet and a rotary discharge valve.

70. A method according to Claim 45 wherein said basket centrifuge is capable of being loaded or charged at low speed, accelerated to recover IF at about 2000-2500 x g and leaf material is discharged through a split rotor design.

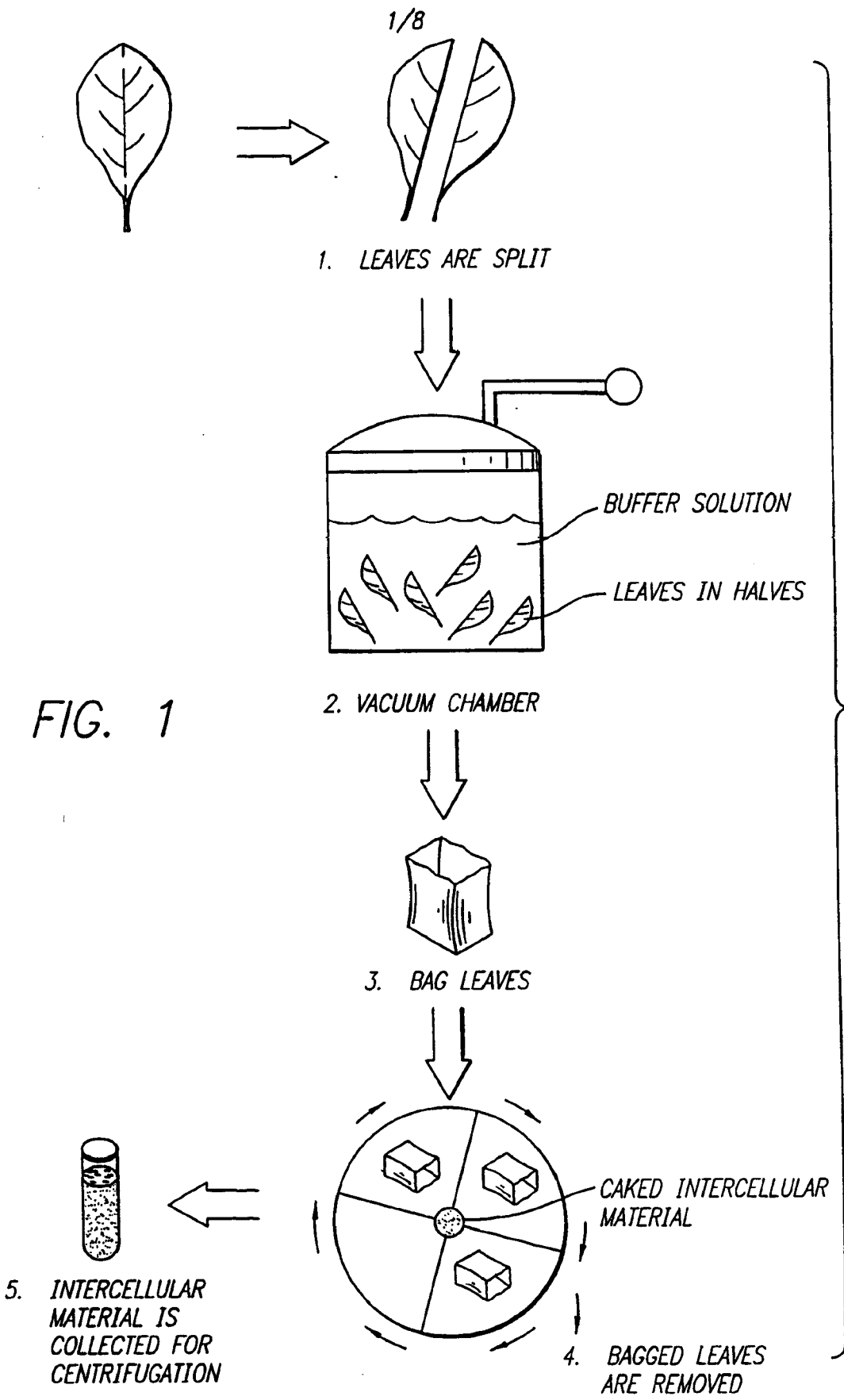
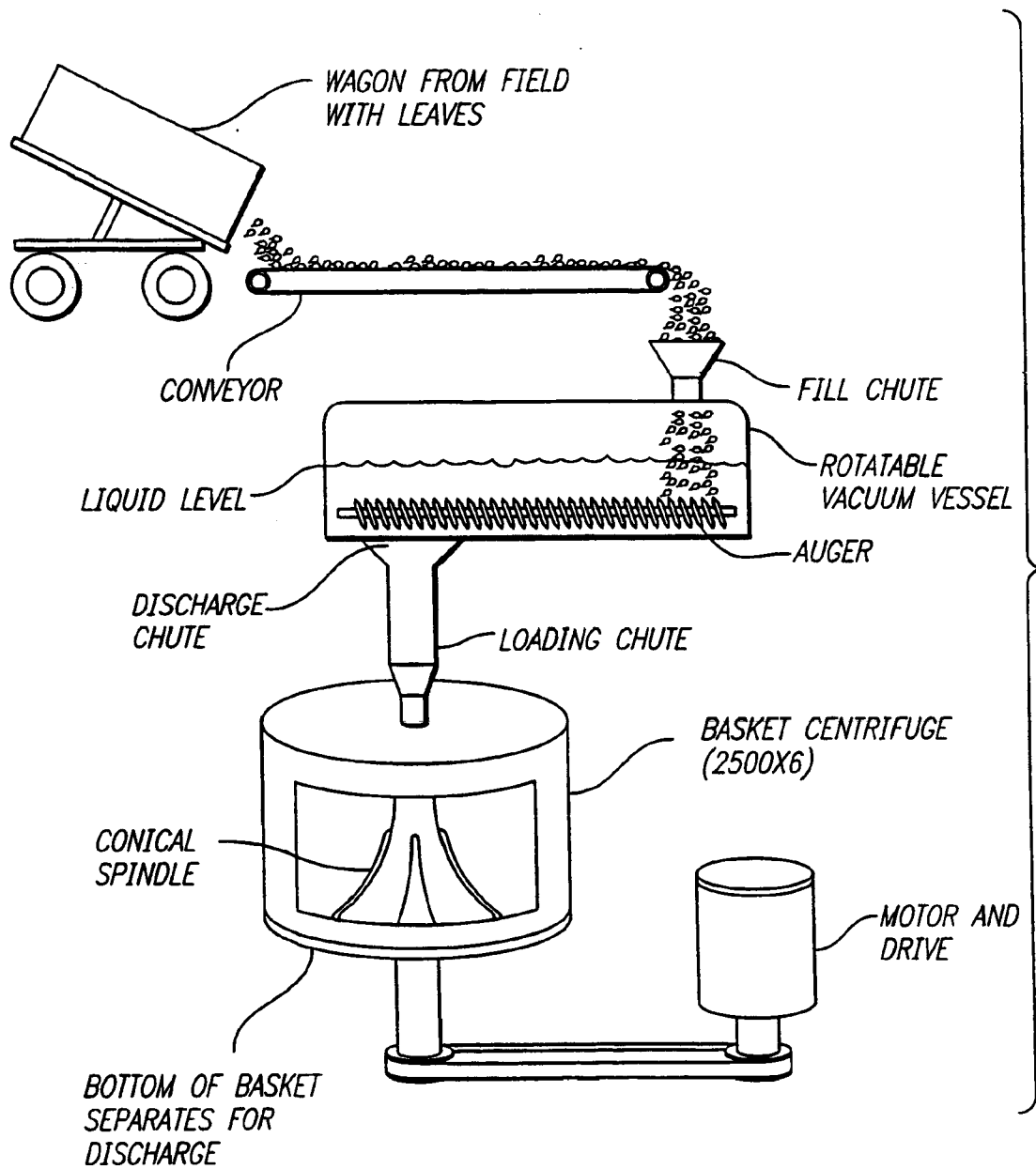

FIG. 1

BATCH VESSEL INFILTRATION

FIG. 2



CONTINUOUS VACUUM INFILTRATION

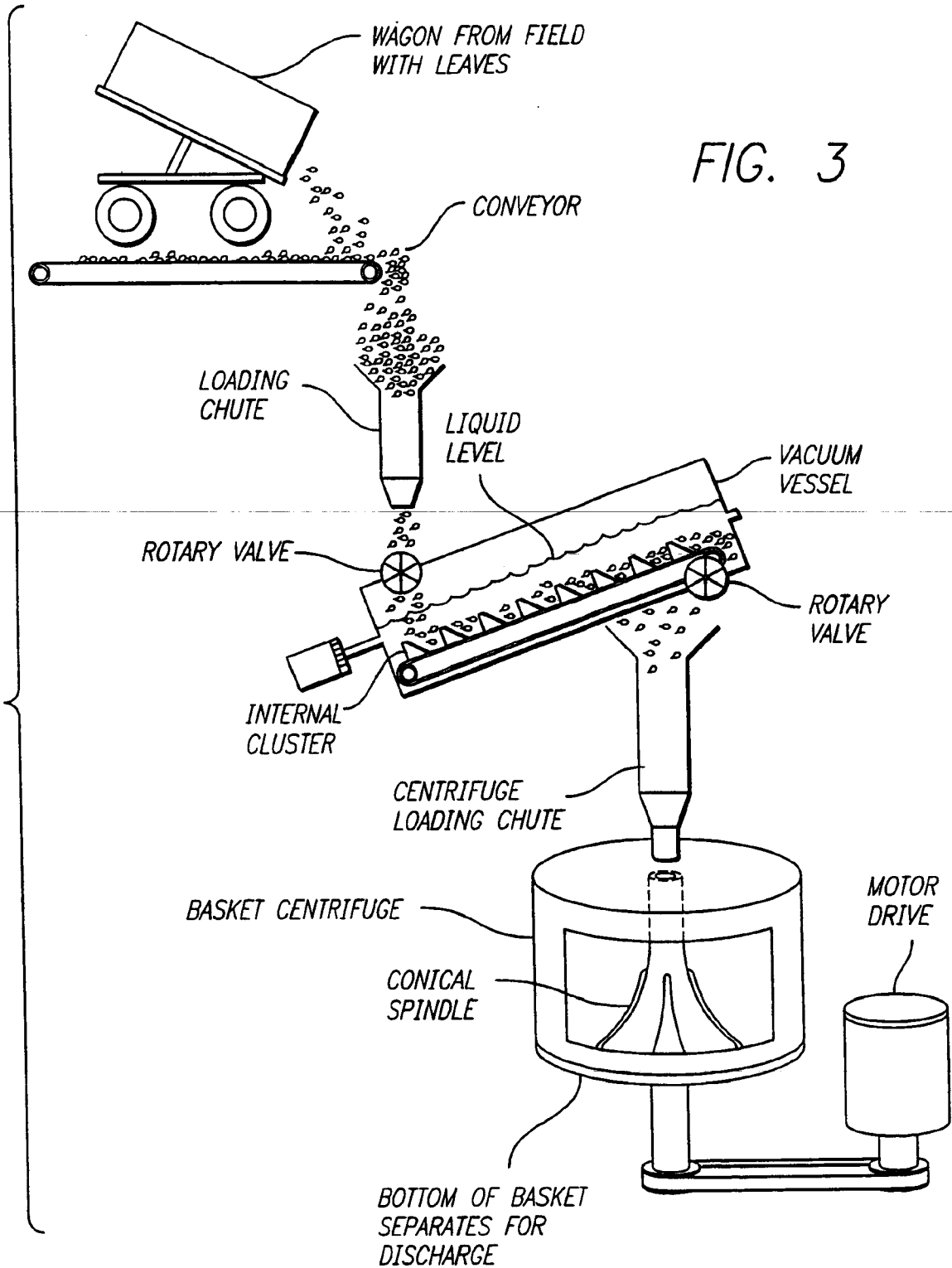

FIG. 4

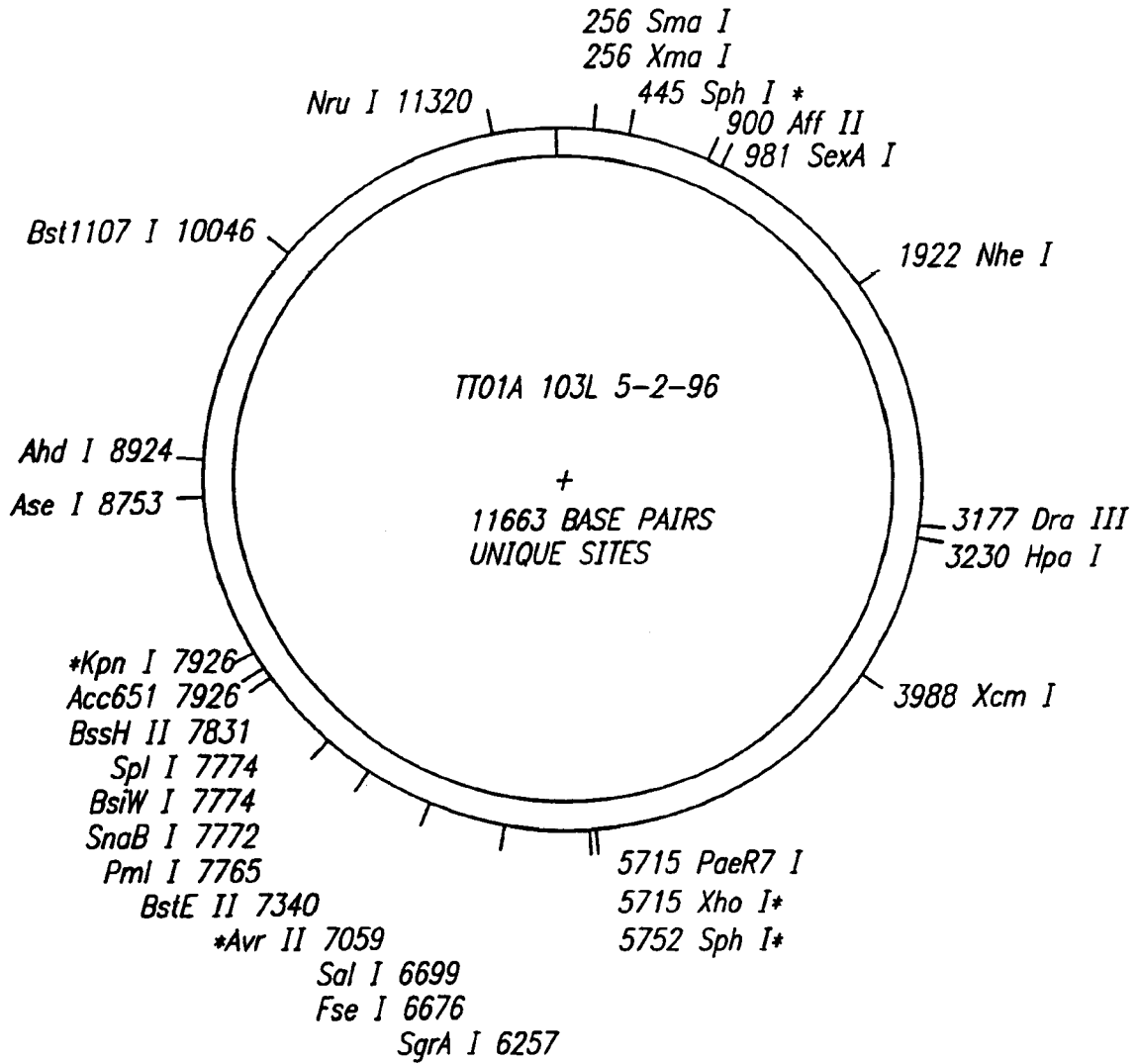

FIG. 5-A

TT01A 103L Viral cDNA

SUBSTITUTE SHEET (RULE 26)

	10	20	30	40	50	60	70	80	
1	gtatttttac	aacaattacc	aacaacaaca	aacaacaac	aacattacaa	ttactattta	caattacaAT	GGCATACACA	80
81	CAGACAGCTA	CCACATCAGC	TTTGCTGGAC	ACTGTCCGAG	GAAACAACCT	CTTGGTCAAT	GATCTAGCAA	AGCGTCGTCT	160
161	TTACGACACA	GCGGTTGAAG	AGTTTAAACGC	TCGTGACCCG	AGGCCAAAGG	TGAACTTTTC	AAAAGTAATA	AGCGAGGAGC	240
241	AGACGCTTAT	TGCTACCCGG	GCGTATCCAG	AATTCCAAAT	TACATTTTAT	AACACGCCAA	ATGCCGTGCA	TTCGCTTGCA	320
321	GGTGGATTGC	GATCTTTAGA	ACTGGAATAT	CTGATGATGC	AAATTCCTTA	CGGATCATTG	ACTTATGACA	TAGGCGGGAA	400
401	TTTTGCATCG	CATCTGTCCA	AGGGACGAGC	ATATGTACAC	TGCTGCATGC	CCAACCTGGA	CGTTCGAGAC	ATCATGCGGC	480
481	ACGAAGGCCA	GAAAGACAGT	ATTGAACTAT	ACCTTTCTAG	GCTAGAGAGA	GGGGGGAAAA	CAGTCCCAA	CTTCCAAAAG	560
561	GAAGCATTTG	ACAGATACGC	AGAAATTCCT	GAAGACGCTG	TCTGTACAAA	TACTTTCCAG	ACAATGCCAC	ATCAGCCGAT	640
641	GCAGCAATCA	GBCAGAGTGT	ATGCCATTGC	GCTACACAGC	ATATATGACA	TACCAGCCGA	TGAGTTCGGG	CGGCACTCT	720
721	TGAGGAAAAA	TGTCATACG	TGCTATGCCG	CTTCCACTT	CTCTGAGAAC	CTGCTTCTTG	AAGATTCATA	CGTCAATTTG	800
801	GACGAAATCA	ACGCGTGT	TTCCGCGCAT	GGAGACAAGT	TGACCTTTTC	TTTTGCATCA	GAGAGTACTC	TTAATTATTG	880
881	TCATAGTTAT	TCTAATATTC	TTAAGTATGT	GTGCAAAACT	TACTTCCCGG	CCTCTAATAG	AGAGGTTTAC	ATGAAGGAGT	960
961	TTTTAGTCAC	CAGAGTTAAT	ACCTGGTTTT	GTAAGTTTTC	TAGAATAGAT	ACTTTTCTTT	TGTACAAAAG	TGTGGCCCAT	1040
1041	AAAAGTGTAG	ATAGTGAGCA	GTTTTATACT	GCAATGGAAG	ACGCATGGCA	TTACAAAAG	ACTCTTGCAA	TGTGCAACAG	1120
1121	CGAGAGAATC	CTCCTTGAGG	ATTCATCATC	AGTCAATTAC	TGGTTTCCCA	AAATGAGGGA	TATGGTCATC	GTACCATTAT	1200
1201	TCGACATTTT	TTTGGAGACT	AGTAAGAGGA	CGCGCAAGGA	AGTCTTAGTG	TCCAAGGATT	TCGTGTTTAC	AGTGCTTAAC	1280
1281	CACATTCGAA	CATACCAGGC	GAAAGCTCTT	ACATACGCAA	ATGTTTTGTC	CTTTGTGCAA	TCGATTCGAT	CGAGGGTAAT	1360
1361	CATTAACGGT	GTGACAGCGA	GGTCCGAATG	GGATGTGGAC	AAATCTTTGT	TACAATCCTT	GTCCATGAGC	TTTACCTGC	1440
1441	ATACTAAGCT	TGCCGTTCTA	AAGGATGACT	TACTGATTAG	CAAGTTTAGT	CTCGGTTCGA	AAACGGTGTG	CCAGCATGTG	1520
1521	TGGGATGAGA	TTTCGCTGGC	GTTTGGGAAC	GCAATTCCTT	CCGTGAAAGA	GAGGCTCTTG	AACAGGAAAC	TTATCAGAGT	1600
1601	GGCAGGCCGAC	GCATTAGAGA	TCAGGGTGCC	TGATCTATAT	GTGACCTTCC	ACGACAGATT	AGTGACTGAG	TACAAGGCCCT	1680
1681	CTGTGGACAT	GCCTGCGCTT	GACATTAGGA	AGAAGATGGA	AGAAACGGAA	GTGATGTACA	ATGCACCTTC	AGAGTTATCG	1760
1761	GTGTTAAGGG	AGTCTGACAA	ATTCGATGTT	GATGTTTTTT	CCCAGATGTG	CCAATCTTTG	GAAGTTGACC	CAATGACGGC	1840
1841	AGCGAAGGTT	ATAGTCGCGG	TCATGAGCAA	TGAGAGCGGT	CTGACTCTCA	CATTTGAACG	ACCTACTGAG	CGGAATGTTG	1920
1921	CGCTAGCTTT	ACAGGATCAA	GAGAAGGCTT	CAGAAGGTGC	TTTGGTAGTT	ACCTCAAGAG	AAGTTGAAGA	ACCGTCCATG	2000
2001	AAGGGTTCGA	TGGCCAGAGG	AGAGTTACAA	TTAGCTGGTC	TTGCTGGAGA	TCATCCGGAG	TCGTCTATT	CTAAGAACGA	2080
2081	GGAGATAGAG	TCTTTAGAGC	AGTTTCATAT	GGCAACGGCA	GATTCGTTAA	TTGTAAGCA	GATGAGCTCG	ATTGTGTACA	2160
2161	CGGGTCCGAT	TAAAGTTCAG	CAAATGAAAA	ACTTTATCGA	TAGCCTGGTA	GCATCACTAT	CTGCTCGGTT	GTCGAATCTC	2240
2241	GTCAAGATCC	TCAAAGATAC	AGCTGCTATT	GACCTTGAAA	CCCGTCAAAA	GTTTGGAGTC	TTGGATGTTG	CATCTAGGAA	2320

FIG. 5-B

SUBSTITUTE SHEET (RULE 26)

2321 GTGGTTAATC AAACCAACGG CCAAGAGTCA TGCATGGGGT GTTGTGAAA CCCACGCGAG GAAGTATCAT GTGGCGCTTT 2400
 2401 TGGAAATATGA TGAGCAGGGT GTGGTGACAT GCGATGATTG GAGAAGAGTA GCTGTCAGCT CTGAGTCTGT TGTTTATTCC 2480
 2481 GACATGGCGA AACTCAGAAC TCTGCGCAGA CTGCTTCGAA ACGGAGAACC CGATGTCAGT A6CGCAAAGG TTGTTCTTGT 2560
 2561 GGACGGAGTT CCGGGCTGTG GGAAAAACCA AGAAATCTTT TCCAGGGTTA ATTTTGATGA AGATCTAATT TTAGTACCTG 2640
 2641 GGAAGCAAGC CGCGAAATG ATCAGAAGAC GTGCGAATTC CTCAGGGATT ATTGTGGCCA CGAAGGACAA CGTAAAAACC 2720
 2721 GTTGATTCTT TCATGATGAA TTTTGGGAAA AGACACAGCT GTCAGTTCAA GAGGTTATTG ATTGATGAAG GGTGATGTT 2800
 2801 GCATACTGGT TGTGTTAATT TTCTTGTGGC GATGTCATTG TCGGAAATTG CATATGTTTA CGGAGACACA CAGCAGATTG 2880
 2881 CATAACATCA TAGAGTTTCA GGATTCCCGT ACCCGGCCA TTTTGCCAAA TTGGAAGTTG ACGAGGTGGA GACACGCAGA 2960
 2961 ACTACTCTCC GTTGTCCAGC CGATGTCACA CATTATCTGA ACAGGAGATA TGAGGGCTTT GCATGAGCA CTCTTCGGT 3040
 3041 TAAAAAGTCT GTTTCGCAGG AGATGGTCCG CGGAGCCGCC GTGATCAATC CGATCTCAA ACCCTTCCAT GGCAAGATCC 3120
 3121 TGACTTTTAC CCAATCGGAT AAAGAAGCTC TGCTTCAAG AGGGTATTCA GATGTTTACA CTGTGCATGA AGTGAAGGC 3200
 3201 GAGACATACT CTGATGTTTC ACTAGTTAGG TTAACCCCTA CACCAGTCTC CATCATTGCA GGAGACAGCC CACATGTTTT 3280
 3281 GGTCGCATTG TCAAGGCACA CCTGTTGCT CAAGTACTAC ACTGTTGTTA TGGATCCTTT AGTTAGTATC ATTAGAGATC 3360
 3361 TAGAGAAACT TAGCTCGTAC TTGTTAGATA TGTATAAGGT CGATGCAGGA ACACAATAGC AATTACAGAT TGAATCGGTG 3440
 3441 TTCAAAGBT CCAATCTTTT TGTTGCAGCG CCAAGACTG GTGATATTTG TGATATGCG TTTTACTATG ATAAGTGTCT 3520
 3521 CCCAGGCAAC AGCACCATGA TGAATAATTT TGATGCTGTT ACCATGAGGT TGACTGACAT TTCATTGAAT GTCAAAGATT 3600
 3601 GCATATTGGA TATGTCTAAG TCTGTTGCTG CGCCTAAGGA TCAAATCAA CCACTAATAC CTATGGTACG AACGGCGGCA 3680
 3681 GAAATGCCAC GCCAGACTGG ACTATTGGAA AATTTAGTGG CGATGATTA AAGGAACTTT AACGCACCCG AGTTGTCTGG 3760
 3761 CATCATTGAT ATTGAAAATA CTGCATCTTT AGTTGTAGAT AAGTTTTTTG ATAGTTATTT GCTTAAAGAA AAAAGAAAAC 3840
 3841 CAAATAAAAA TGTTTCTTTG TTCAGTAGAG AGTCTCTCAA TAGATGGTTA GAAAAGCAGG AACAGGTAAC AATAGGCCAG 3920
 3921 CTCGCAGATT TGATTTTTG AGATTTGCCA GCAGTTGATC AGTACAGACA CATGATTAAG GCACAACCCA AGCAAAAATT 4000
 4001 GGACACTTCA ATCCAAACGG AGTACCCGGC TTTGCAGACG ATTGTGTACC ATTCAAAAA GATCAATGCA ATATTTGGCC 4080
 4081 CGTTGTTTAG TGAGCTTACT AGGCAATTAC TGGACAGTGT TGATTCGAGC AGATTTTTGT TTTTCACAAG AAAGACACCA 4160
 4161 GCGCAGATTG CGGATTTCTT CGGAGATCTC GACAGTCATG TGCCGATGGA TGCTTTGGAG CTGGATATAT CAAAATACGA 4240
 4241 CAAATCTCAG AATGAATTC ACTGTGAGT AGAATACGAG ATCTGGCGAA GATTGGGTTT TGAAGACTTC TTGGGAGAAG 4320
 4321 TTTGGAAACA AGGGCATAGA AAGACCCCTC TCAAGGATTA TACCGCAGGT ATAAAAACT GCATCTGGTA TCAAAGAAAG 4400
 4401 AGCGGGGACG TCACGACGTT CATTGGAAAC ACTGTGATCA TTGCTGCATG TTTGGCCTCG ATGCTTCCGA TGGAGAAAAT 4480
 4481 AATCAAAGGA GCCTTTTTCG GTGACGATAG TCTGCTGTAC TTTCCAAAGG GTTGTGAGTT TCCGGATGTG CAACACTCCG 4560
 4561 CGAATCTTAT GTGGAATTTT GAAGCAAAAC TGTTAAAAA ACAGTATGGA TACTTTTTCG GAAGATATGT AATACATCAC 4640
 4641 GACAGAGGAT GCATTGTGTA TTACGATCCC CTAAGTTGA TCTCGAAACT TGGTGCTAAA CACATCAAGG ATTGGGAACA 4720

FIG. 5-C

SUBSTITUTE SHEET (RULE 26)

4721 CTTGGAGGAG TTCAGAAGGT CTCTTTGTGA TGTGTCTGTT TCGTTGAACA ATTGTGCGTA TTACACACAG TTGGACGACG 4800
4801 CTGTATGGGA GGTTCATAAG ACCGCCCTC CAGGTTCTGT TGTTTATAAA AGTCTGGTGA AGTATTTGTC TGATAAAGTT 4880
4881 CTTTTAGAA GTTTGTTTAT AGATGGCTCT AGTTGTAAA GGAAGAGTGA ATATCAATGA GTTTATCGAC CTGACAAAAA 4960
4961 TGGAGCCGAT CTTACCGTCC ATGTTTACCC CTGTAAGAG T6TTATGTGT TCCAAAGTGT ATAAAAAAT G6TTCATGAG 5040
5041 AATGAGTCAT TGTGAGAGGT GAACCTTCTT AAAGGAGTTA AGCTTATTGA TAGTGGATAC GTCTGTTTAG CCGGTTTGGT 5120
5121 CGTACGGGC GAGTGGAACT TGCCTGACAA TTGCAGAGGA GGTGTGAGCG TGTGTCTGGT GGACAAAAGG ATGGAAAAGAG 5200
5201 CCGACGAGGC CACTCTCGGA TCTTACTACA CAGCAGCTGC AAAGAAAAGA TTTGAGTCA AGGTCGTTCC CAATTATGCT 5280
5281 ATAACCACCC AGGACGCGAT GAAAAACGTC TGGCAAGTTT TAGTTAATAT TAGAAAATGTG AAGATGTCAG CCGGTTTCTG 5360
5361 TCCGCTTTCT CTGGAGTTTG TGTGCGGTG TATTGTTTAT AGAATAATA TAAAATTAGG TTTGAGAGAG AAGATTACAA 5440
5441 ACGTGAGAGA CCGAGGGCCC ATGGAACCTA CAGAAGAAGT CGTTGATGAG TTCATGGAAG ATGTCCTAT GTCGATCAGG 5520
5521 CTTGCAAGT TTCGATCTCG AACCCGAAAA AAGAGTGATG TCCGCAAAGG GAAAAATAGT AGTAATGATC G6TCAGTGCC 5600
5601 GAACAAGAAC TATAGAAATG TTAAGGATTT TGGAGGAATG AGTTTTAAAA AGAATAATTT AATCGATGAT GATTCCGAGG 5680
5681 CTA CTGTCTGC CGAATCGGAT TCGTTTTAAA TACGCTCGAG ATCAATCATC CATCTCCGAA GTGTGCTGCG AGCATGACGG 5760
5761 TGCTGAACAC CATGGTGAAC AAACACTTCT TGTCCCTTTC GGTCTCTATC GTCCTCCTTG GCCTCTCCTC CAACTTGACA 5840
5841 GCCGGGCAAG TCCTGTTTCA GGGATTCAAC TGGGAGTCGT GGAAGGAGAA TGGCGGGTGG TACAACCTCC TGATGGGCAA 5920
5921 GGTGGACGAC ATCCGCCGAG CCGGCATCAC CCACGTCTGG CTCCCTCCGC CGTCTCACTC TGTCGGAGAG CAAGGCTACA 6000
6001 TGCCTGGGCG GCTGTACGAT CTGGACGCGT CTAAGTACGG CAACGAGGCG CAGCTCAAGT CGCTGATCGA G6CGTTCCAT 6080
6081 GGCAAGGGCG TCCAGGTGAT CGCCGACATC GTCATCAACC ACCGCACGGC GGAGCACAAG GACGGCCGAG GCATCTACTG 6160
6161 CCTCTTCGAG GGCGGGACGC CCGACTCCCG CCTCGACTGG G6CCCGCACA TGATCTGCCG CGACGACCCC TACGGCGATG 6240
6241 GCACCCGCAA CCCGGACACC GGC6CGACT TCGCCGCGC G6CGGACATC GACCACCTCA ACAAGCGCGT CCAGCGGGAG 6320
6321 CTCATTGGCT G6CTCGACTG GCTCAAGATG GACATCGGCT TCGACGCGT GCGCCTCGAC TTCGCCAAGG GCTACTCCGC 6400
6401 CGACATGGCA AAGATCTACA TCGACGCCAC CGAGCCGAGC TTCGCGTGG CCGAGATATG GACGTCCATG GCGAACGGCG 6480
6481 GGGACGGCAA GCCGAACACT GACCAGAACG CGCACCGGCA GGAGCTGGTC AACTGGGTCG ATCGTGTCCG G6GCGCCAAC 6560
6561 AGCAACGGCA CCGCGTTCGA CTTCCACCAC AAGGGCATCC TCAACGTCGC CGTGGAGGGC GAGCTGTGGC GCCTCCGCGG 6640
6641 CGAGGACGGC AAGGCGCCCG GCATGATCGG GTGGTGGCCG GCCAAGGCGA CGACCTTCTG CGACAACCAC GACACCGGCT 6720
6721 CGACGACGCA CCGTGGCCG TTCCCTCCG ACAAGGTCAT GCAGG6CTAC GCATACATCC TCACCCACCC G6GCAACCCA 6800
6801 TGCATCTTCT ACGACCATTT CTTGATGGG GGTCTCAAGG AGGAGATCGA GCGCCTGGTG TCAATCAGAA ACCGGCAGGG 6880
6881 GATCCACCCG GCGAGCGAGC TCGCATCAT GGAAGCTGAC AGCGATCTCT ACCTCGCGGA GATCGATGGC AAGGTGATCA 6960
6961 CAAAGATTGG ACCAAGATA GAGCTCGAAC ACCTCATCCC CGAAGGCTTC CAGGTGCTCG CGCACGGTGA TGGCTACGCA 7040
7041 ATCTGGGAGA AAATCTGACC taggctcgca aagtttcgaa ccaaatcctc aaaaagaggt ccgaaaaata ataataattt 7120

FIG. 5-D

7121 aggtaagggg cgttcaggcg gaaggcctaa accaaaaagt tttgatgaag ttgaaaaaga gtttgataat ttgattgaag 7200
7201 atgaagccga gacgtcggtc gcggattctg attcgtatta aatATGTCTT ACTCAATCAC TTCTCCATCG CAATTTGTGT 7280
7281 TTTTGCATC TGTATGGGCT GACCCATAG AATTGTTAAA CGTTTGACA AATTCGTTAG GTAACCACTT TCAAACACAG 7360
7361 CAAGCAAGAA CTAAGTTTCA ACAGCAGTTC AGCGAGGTGT GGAAACCTT CCCTCAGAGC ACCGTCAGAT TTCCTGGCGA 7440
7441 TGTATATAAG GTGTACAGGT ACAATGCAGT TTTAGATCCT CTAATTAAGT CGTTGCTGGG GGTCTTTGAT ACTAGGAATA 7520
7521 GAATAATCGA AGTAGAAAAC CAGCAGAGTC CGACAACAGC TGAACGTTA GATGCTACC GCAGGGTAGA CGACGCTACG 7600
7601 GTTGCAATTC GGTCTGCTAT AAATAATTTA GTTAATGAAC TAGTAAGAGG TACTGGACTG TACAATCAGA ATACTTTTGA 7680
7681 AAGTATGTCT GGGTTGGTCT GGACCTCTGC ACCTGCATCT TAAATGCATA ggtgctgaaa tataaagttt gtgtttctaa 7760
7761 aacacacgtg gtacgtacga taacgtacag tgttttccc tggacttaa tcgaagggtg gtgtcttggg gcgcgcggag 7840
7841 taaacatata tggttcatat atgtccgtag gcacgtaaaa aaagcgaggg attcgaattc ccccggaacc cccggttggg 7920
7921 gcccaG
| 10 | 20 | 30 | 40 | 50 | 60 | 70 | 80

SUBSTITUTE SHEET (RULE 29)