



(19) **United States**
(12) **Patent Application Publication**
Chen

(10) **Pub. No.: US 2008/0117635 A1**
(43) **Pub. Date: May 22, 2008**

(54) **MULTI-LAYER LIGHT GUIDING STRUCTURE AND METHOD FOR USING THE SAME**

(52) **U.S. Cl. 362/293; 362/311**

(76) **Inventor: Ko-Ju Chen, Taoyuan (TW)**

(57) **ABSTRACT**

Correspondence Address:
HDSL
4331 STEVENS BATTLE LANE
FAIRFAX, VA 22033

A key module with a multi-layer light guiding structure includes a plurality of keys, light guiding structure and a plurality of light blocks corresponding to the light guiding structure. The light guiding structure includes a plurality of light guiding plates. Each of the light guiding plate includes at least one light guiding strip corresponding to specific keys, which are staggered to each other or corresponding to each other. The light guiding strip is provided with a color layer. An electronic device using the key module individually or selectively lights light emitting elements for each layer of the light guiding plates. Therefore, different lights are emitted from the light guiding strips or a mixed light is produced from the light guiding strips to illuminate the keys. The keys have lights of different color to manifest symbols or alphabets on the keys.

(21) **Appl. No.: 11/560,962**

(22) **Filed: Nov. 17, 2006**

Publication Classification

(51) **Int. Cl.**
F21V 3/00 (2006.01)
F21V 9/00 (2006.01)

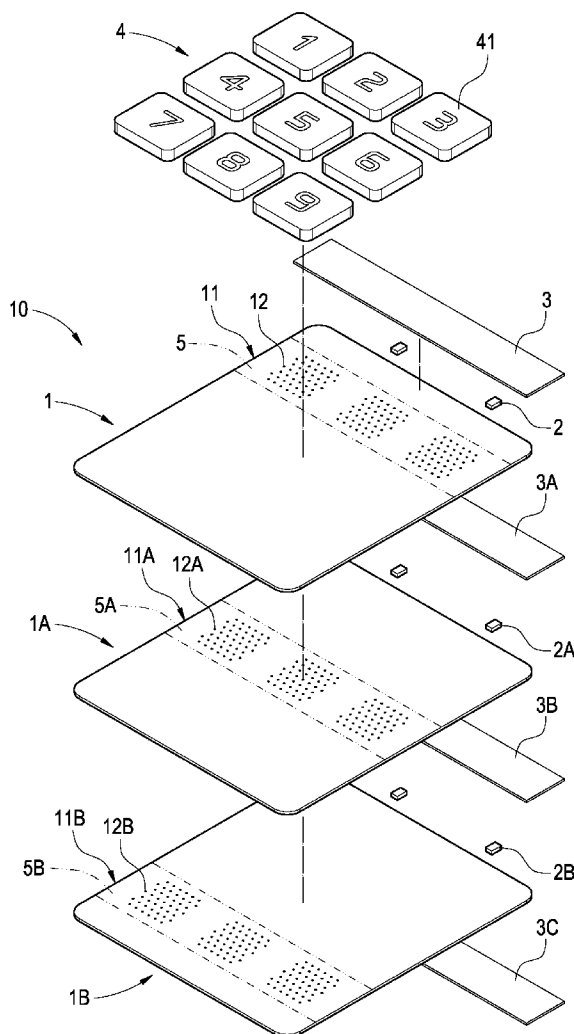

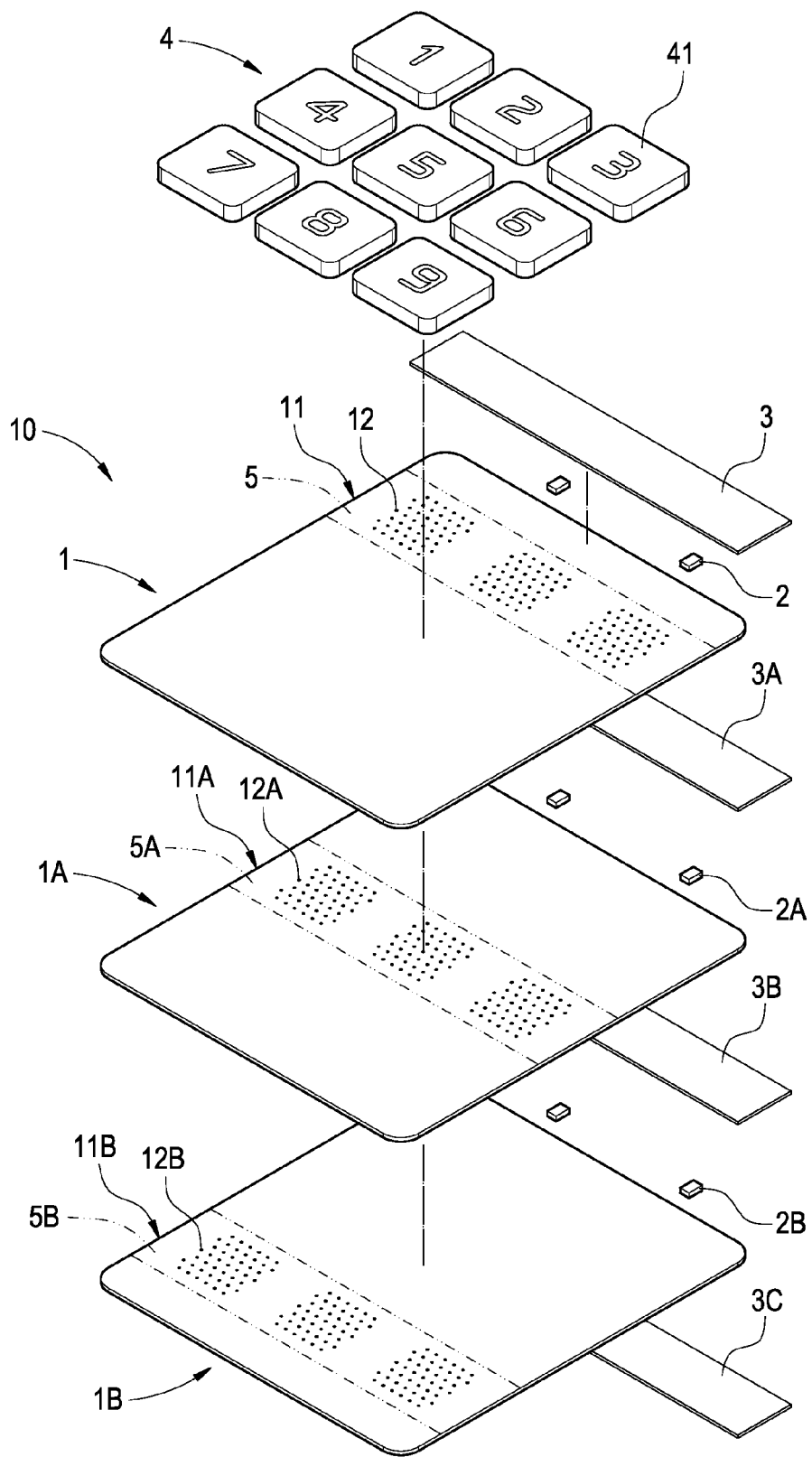

FIG.1

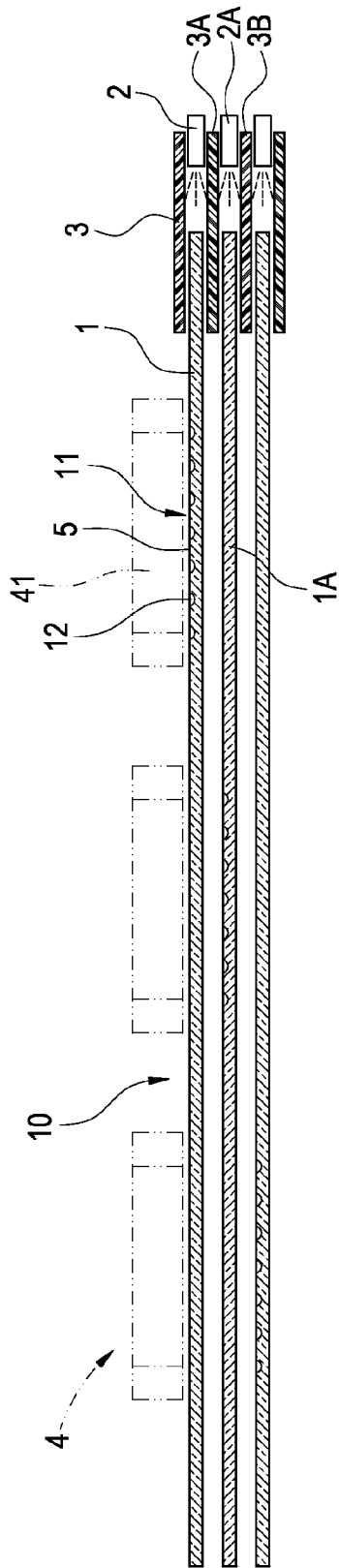

FIG.2

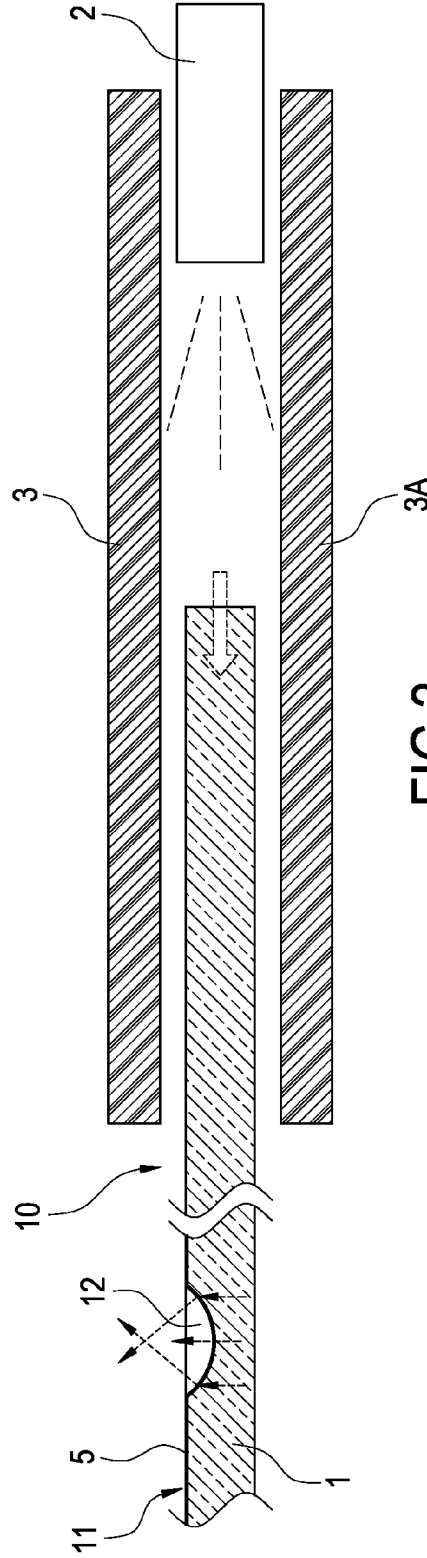

FIG.3

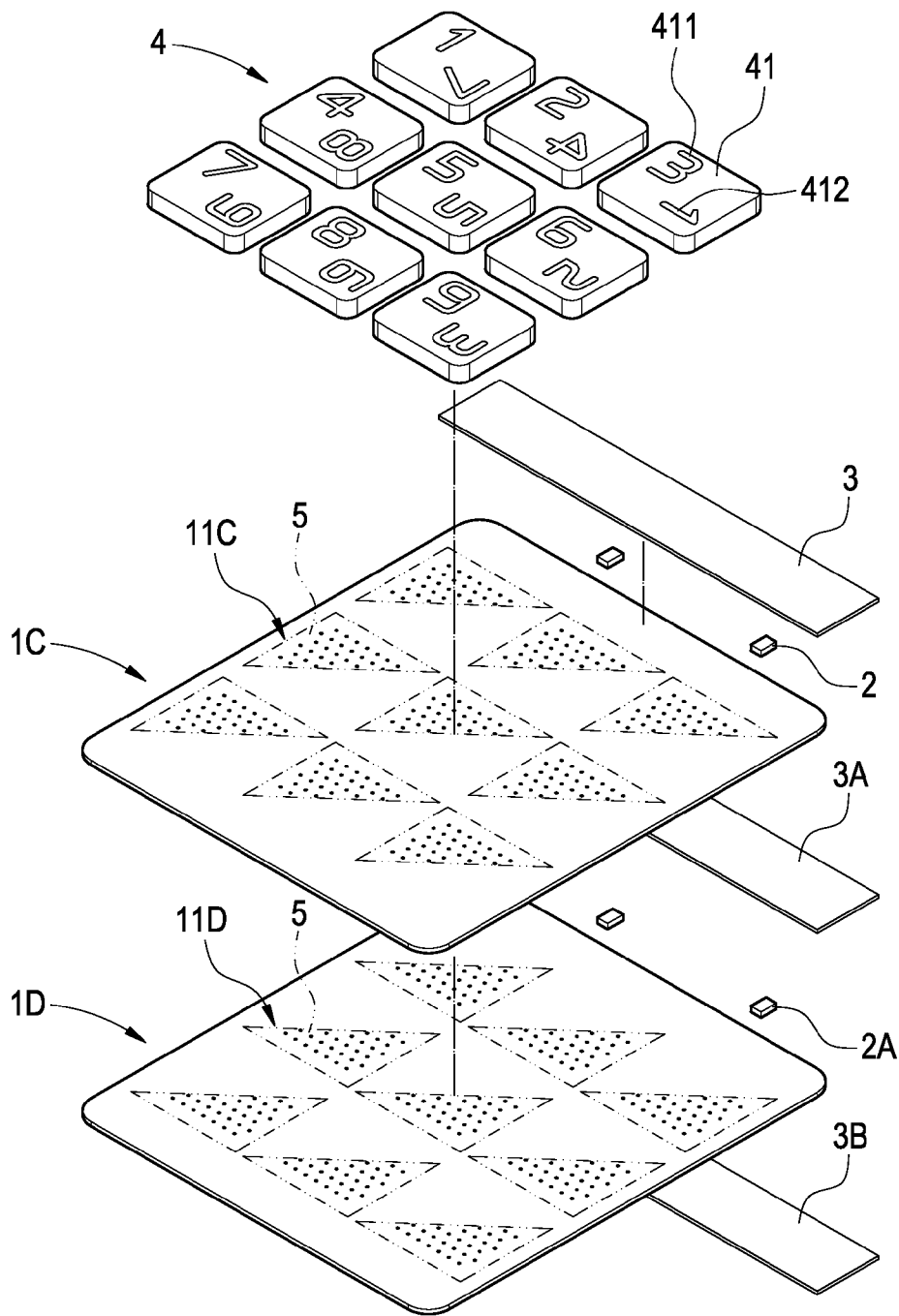

FIG.4

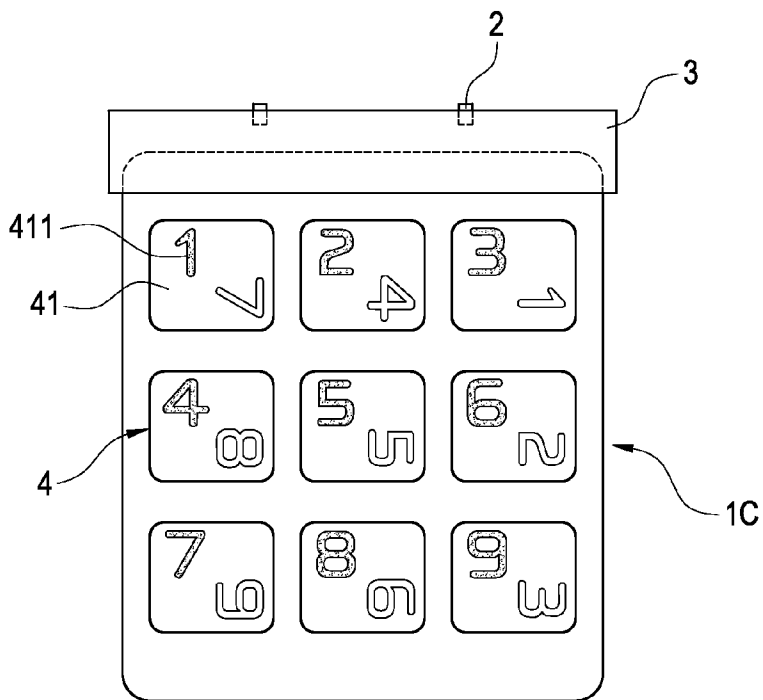

FIG. 5

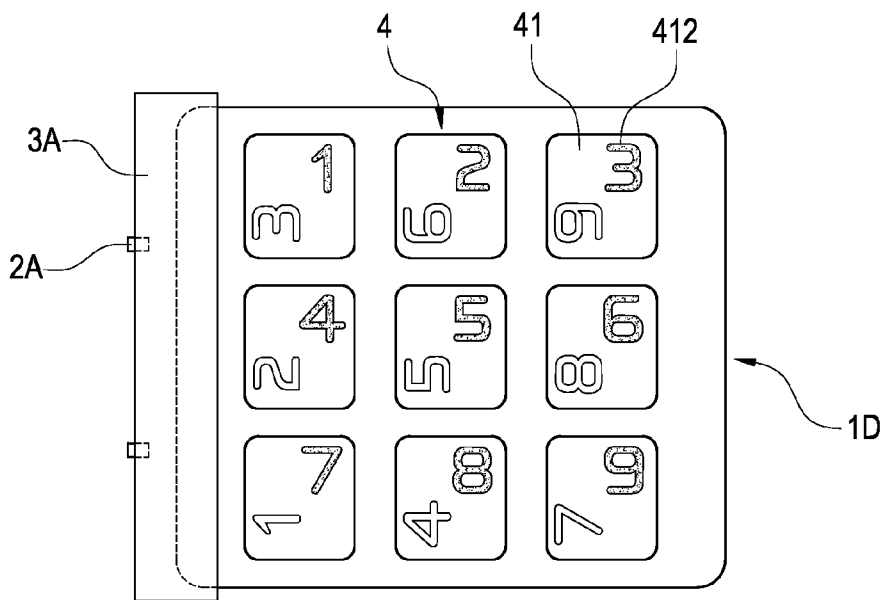

FIG. 6

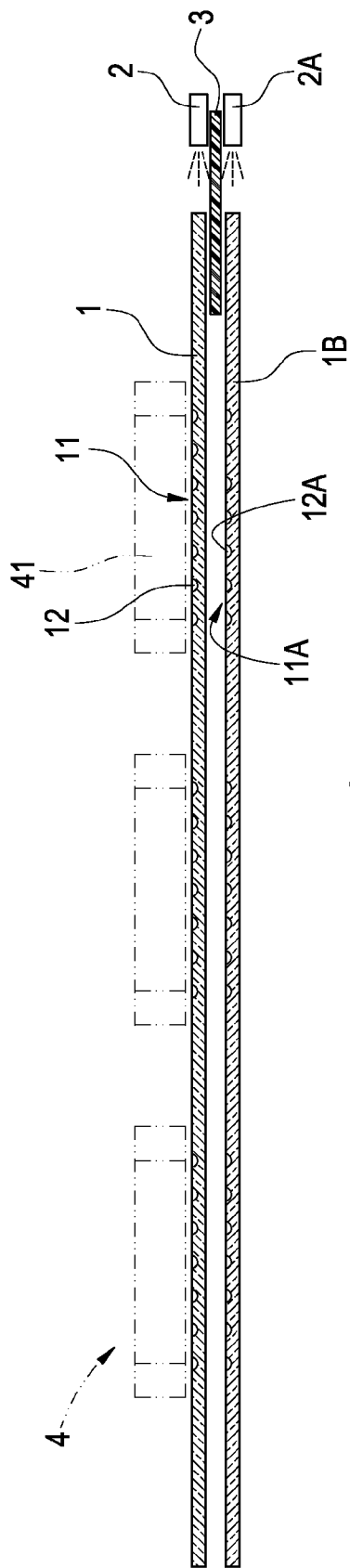

FIG.7

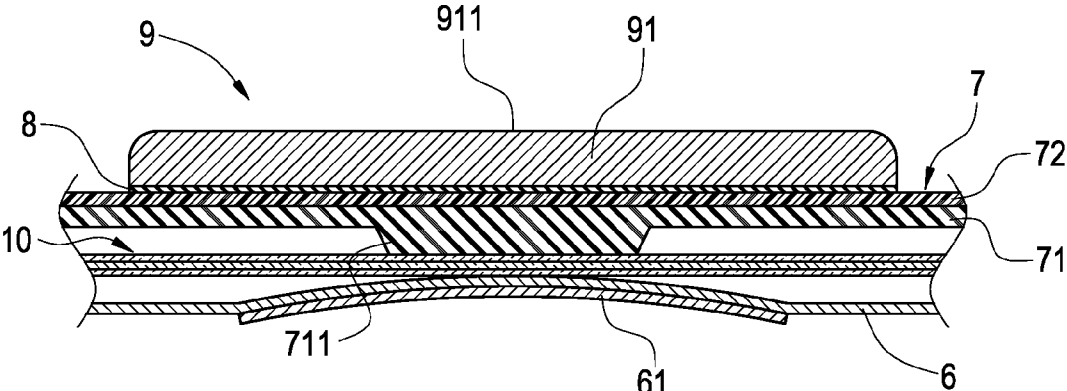

FIG.8

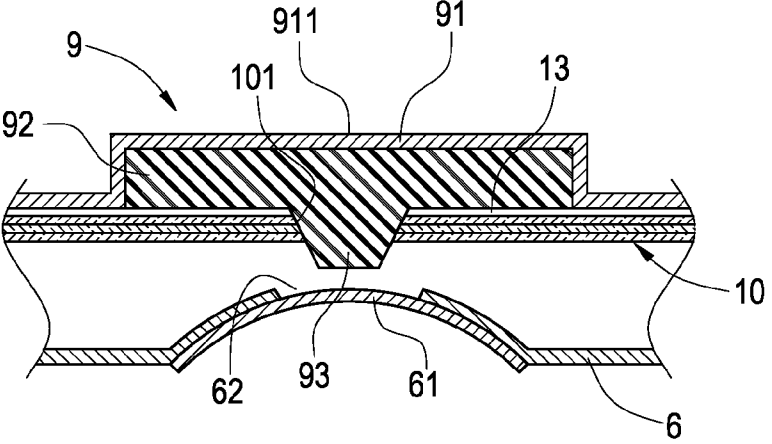

FIG.9

**MULTI-LAYER LIGHT GUIDING
STRUCTURE AND METHOD FOR USING
THE SAME**

BACKGROUND OF THE INVENTION

[0001] 1. Field of the Invention

[0002] The present invention relates to a light guiding plate, more particularly, to a multi-layer light guiding structure

[0003] 2. Description of Prior Art

[0004] Portable electronic device such as mobile phones and personal digital assistants (PDA) are popular information appliances. In those portable electronic devices, keys are often used for user input interface to input data and select function of the electronic devices.

[0005] The key in the prior art electronic device generally comprises a backlight to provide illumination for user in dark environment. Therefore, user can correctly identify key. The conventional backlight comprises a transparent light guide and a light emitting diode (LED) in the electronic device. Light emitted from the LED is guided by the light guide to distribute over bottom of each key. Therefore, symbols or alphabet can be clearly displayed on the key.

[0006] The LED in backlight application is generally of mono color, therefore, symbols or alphabet formed on top of the key are printed with different color to provide colorful display effect. Alternatively, a multiple-color LED is used for a key when a specific color effect is demanded for the key. The manufacture time and cost for above two approaches are burden for the manufacturer.

[0007] As the progress of technology, the electronic device is also provided with more function for user. For example, mobile phone can be used for photo, game and video playback. However, the backlight in the mobile phone illuminates symbols and alphabet on all keys. Therefore, user cannot identify the key for game control, photo shooting or video playing and the user is liable to have wrong operation. Moreover, the mobile phone may be rotated during game control, photo shooting or video playing operation. The symbols and alphabet on the keys have different orientation and the user cannot identify the key for game control, photo shooting or video playing, especially when the symbols and alphabet on the keys are transparent.

SUMMARY OF THE INVENTION

[0008] The invention is to provide a multi-layer light guiding structure to control the light emission from one key or multiple keys, whereby user can clearly find the right keys.

[0009] Accordingly, the present invention provides a key module with a multi-layer light guiding structure, which includes a plurality of keys, light guiding structure and a plurality of light blocks corresponding to the light guiding structure. The light guiding structure includes a plurality of light guiding plates. Each of the light guiding plate includes at least one light guiding strip corresponding to specific keys, which are staggered to each other or corresponding to each other. The light guiding strip is provided with a color layer. An electronic device using the key module individually or selectively lights light emitting elements for each layer of the light guiding plates. Therefore, different lights are emitted from the light guiding strips or a mixed light is produced from the

light guiding strips to illuminate the keys. The keys have lights of different color to manifest symbols or alphabets on the keys.

BRIEF DESCRIPTION OF DRAWING

[0010] The features of the invention believed to be novel are set forth with particularity in the appended claims. The invention itself however may be best understood by reference to the following detailed description of the invention, which describes certain exemplary embodiments of the invention, taken in conjunction with the accompanying drawings in which:

[0011] FIG. 1 shows the first preferred embodiment of the present invention.

[0012] FIG. 2 shows a top view of the first preferred embodiment of the present invention.

[0013] FIG. 3 shows the light refraction path of the first preferred embodiment of the present invention.

[0014] FIG. 4 shows the second preferred embodiment of the present invention.

[0015] FIG. 5 shows the key according a preferred embodiment of the present invention.

[0016] FIG. 6 shows the key in another orientation according a preferred embodiment of the present invention.

[0017] FIG. 7 shows the third preferred embodiment of the present invention.

[0018] FIG. 8 shows the fourth preferred embodiment of the present invention.

[0019] FIG. 9 shows the fifth preferred embodiment of the present invention.

DETAILED DESCRIPTION OF THE INVENTION

[0020] FIG. 1 shows the first preferred embodiment of the present invention. The present invention provides a multi-layer light guiding structure 10. The multi-layer light guiding structure 10 comprises a plurality of light guiding plates 1, 1A and 1B, which comprises light guiding strips 11, 11A and 11B corresponding to keys 41. Each of the light guiding strips 11, 11A and 11B comprises pits 12, 12A, and 12B formed on the light guiding plates 1, 1A and 1B, respectively. The pits 12, 12A, and 12B change the optical paths of light to focus the light on specific key 41 through refraction. Each of the light guiding strips 11, 11A and 11B is coated with a specific color and the electronic device lights the light-emitting elements 2, 2A and 2B individually or selectively, whereby light of different color is emitted from the light guiding strips 11, 11A and 11B and illuminates the key module 4. The keys 41 on the key module 4 have illumination of different color to display the alphabets and symbols thereon. In the shown embodiment, the light-emitting elements 2, 2A and 2B are white LEDs.

[0021] The preferred embodiment is exemplified with three layers of light guiding plates.

[0022] In the first light guiding plate 1, a light-emitting element 2 is arranged on one side of the light guiding plate 1 and a light block 3 is arranged atop the light guiding plate 1 and the light-emitting element 2. The light block 3 is functioned to prevent interference of light to other light guiding plate or the key module. A light guiding strip 11 is arranged corresponding to the locations of keys 41 assigned for number "1", "2", and "3". The light guiding strip 11 is coated with red color to form red-color layer 5.

[0023] In the second light guiding plate 1A, a light-emitting element 2A is arranged on one side of the light guiding plate 1A and a light block 3A is arranged atop the light guiding plate 1A and the light-emitting element 2A. The light block 3A is functioned to prevent interference of light to other light guiding plate or the key module. A light guiding strip 1A is arranged corresponding to the locations of keys 41 assigned for number “4”, “5”, and “6”. The light guiding strip 11A is coated with blue color to form blue-color layer 5A.

[0024] In the third light guiding plate 1B, a light-emitting element 2B is arranged on one side of the light guiding plate 1B and a light block 3B is arranged atop the light guiding plate 1B and the light-emitting element 2B. The light block 3B is functioned to prevent interference of light to other light guiding plate or the key module. A light guiding strip 11B is arranged corresponding to the locations of keys 41 assigned for number “7”, “8”, and “9”. The light guiding strip 11B is coated with green color to form green-color layer 5B.

[0025] After the three light guiding plates 1, 1A and 1B are stacked, the light guiding strips 11, 11A and 11B are staggered to each other and corresponding to specific keys 41. Moreover, a light block 3C is provided below the third light guiding plate 1B at the last layer and the light-emitting element 2B. Moreover, when the light-emitting elements 2, 2A and 2B are of different color, for example, red LED, green LED and blue LED, the color layer 5, 5A and 5B can be eliminated for saving cost and reducing process complexity.

[0026] FIGS. 1 to 3 show the first preferred embodiment of the present invention. The electronic device (not shown) controls light source for the multi-layer light guiding structure 10. When the light-emitting element 2 is lighted, the light is guided by the light guiding plate 1 and refracted by the light guiding strip 11 to the specific keys 41 corresponding to numbers “1”, “2”, and “3”. The portion of keys 41 corresponding to numbers “1”, “2”, and “3” are hollow, therefore, red color light can emit from the keys 41 to display numbers “1”, “2”, and “3”. The light block 3 prevents interference of light to the light guiding plate 1A or the key module 4.

[0027] When the light-emitting element 2A is lighted, the light is guided by the light guiding plate 1A and refracted by the light guiding strip 11A to the keys 41 corresponding to numbers “4”, “5”, and “6”. The portion of keys 41 corresponding to numbers “4”, “5”, and “6” are hollow, therefore, blue color light can emit from the keys 41 to display numbers “4”, “5”, and “6”. The light block 3A prevents interference of light to the light guiding plates 1 and 1B or the key module 4.

[0028] When the light-emitting element 2B is lighted, the light is guided by the light guiding plate 1B and refracted by the light guiding strip 11B to the keys 41 corresponding to numbers “7”, “8”, and “9”. The portion of keys 41 corresponding to numbers “7”, “8”, and “9” are hollow, therefore, green color light can emit from the keys 41 to display numbers “7”, “8”, and “9”. The light block 3B prevents interference of light to the light guiding plate 1A.

[0029] When the light-emitting elements 2, 2A and 2B are lighted by the electronic device, the keys 41 corresponding to numbers “1” to “9” have different displaying colors.

[0030] FIG. 4 shows the second preferred embodiment of the present invention. As shown in this figure, each key 41 on the key module 4 comprises alphabets (symbols) 411 and 412 with different orientations.

[0031] The first light guiding plate 1C comprises light guiding area 11C composed of a plurality of pits. The area of the light guiding area 11C is half or less than half of the key 41.

The light guiding area 11C is corresponding to the first number 411 of the key 41 and is coated with a color layer 5. A light block 3 is arranged atop the light guiding plate 1C and the light-emitting elements 2. In this figure, the light-emitting element is white LED.

[0032] The second light guiding plate 1D comprises light guiding area 11D composed of a plurality of pits. The area of the light guiding area 11D is half or less than half of the key 41.

[0033] The light guiding area 11D is corresponding to the second number 412 of the key 41 and is coated with a color layer 5. A light block 3A is arranged atop the second light guiding plate 1D and the light-emitting elements 2A.

[0034] When the two light guiding plates 1C and 1D are stacked, the two light guiding areas 11C and 11D are staggered to each other and corresponding to the two numbers 411 and 412 respectively.

[0035] Moreover, when the light-emitting elements 2 and 2A are of different colors, for example, red LED and green LED, the color layers 5 can be eliminated for saving cost and reducing process complexity.

[0036] With reference to FIGS. 4 to 6, when the light-emitting element 2 is lighted by the electronic device (not shown), the light is guided by the first light guiding plate 1C and illuminates the first number 411 of the key 41 by refraction of the light guiding area 11C. Therefore, light is emitted from the first number 411 while no light is emitted from the second number 412.

[0037] When user rotates the electronic device for playing game or watching video clip, the light-emitting element 2A is lighted. The light is guided by the second light guiding plate 1D and illuminates the second number 412 of the key 41 by refraction of the light guiding area 11D. Therefore, light is emitted from the second number 412 while no light is emitted from the first number 411. Therefore, user can focus his concentration on the right number (symbol) when operating the key 41 and is not influenced by another number of different orientation.

[0038] FIG. 7 shows the third preferred embodiment of the present invention, wherein light guiding strips 11 and 11A are provided for the first light guiding plate 1 and the second light guiding plate 1A. The light guiding strips 11 and 11A are coated with different colors. Therefore, lights can be mixed when the light-emitting elements 2 and 2A are lighted at the same time. For example, when the light-emitting element 2 emits red light and the light-emitting element 2A emits blue light, the mixed color is purple.

[0039] Moreover, a light block 3 is provided between the first light guiding plate 1 and the second light guiding plate 1A, and between the light-emitting element 2 and the light-emitting element 2A to prevent interference therebetween.

[0040] When the light-emitting elements 2 and 2A are implemented with LED of different colors such as red LED and blue LED, the color layers 5 can be eliminated for saving cost and reducing process complexity.

[0041] FIG. 8 shows the fourth preferred embodiment of the present invention. The multi-layer light guiding structure 10 is used for a key structure. The key structure comprises a first elastic layer 6 composed of a plurality of metal plates 61. When the key 91 is pressed, the metal plate 61 is in contact with circuit board of the electronic device (not shown). The metal plate 61 also produces snap sound to provide tactile effect for user.

[0042] A light guiding structure **10** is provided on the first elastic layer **6** and comprises a plurality of light guiding plates. The light guiding structure **10** and related light-emitting element and light block have been described with reference to FIGS. **1** and **7** and description thereof is omitted here for clarity.

[0043] A second elastic layer **7** is provided on the light guiding structure **10** and comprises a rubber body **71** and a rigid plastic film **72** on the surface of the rubber body **71**. The rubber body **71** comprises a projection **711** on bottom thereof and corresponding to the metal plates **61**.

[0044] A binding layer **8** is arranged on the second elastic layer **7**.

[0045] A key module **9** is arranged on the binding layer **8** and comprises a plurality of keys **91**, each of keys **91** is corresponding to a projection **711**.

[0046] When the light-emitting elements are lighted individually or selectively, the light of different colors is guided by corresponding light guiding plates. Therefore, lights of different colors pass through the surface of the keys **91**.

[0047] When a key **91** is pressed by external force, the projection **711** of the rubber body **71** is in contact with the light guiding structure **10** and the first elastic layer **6**. Therefore, the metal plate **61** is in contact with a circuit board of the electronic device (not shown). The metal plate **61** also produces snap sound to provide tactile effect for user.

[0048] FIG. **9** shows the fifth preferred embodiment of the present invention. The multi-layer light guiding structure **10** is used for a key structure.

[0049] The key structure comprises a first elastic layer **6** with a plurality of apertures **62** and a metal plate **61** on opposite face of each aperture **62**. When the key **91** is pressed by external force, the metal plates **61** is in contact with a circuit board of the electronic device (not shown). The metal plate **61** also produces snap sound to provide tactile effect for user.

[0050] A light guiding structure **10** is provided on the first elastic layer **6** and comprises a plurality of light guiding plates. The light guiding structure **10** and related light-emitting element and light block have been described with reference to FIGS. **1** and **7** and description thereof is omitted here for clarity. Each of the light guiding plates comprises a through hole **101** thereon.

[0051] A key module **9** is arranged on the light guiding structure **10** and comprises a plurality of keys **91**, each of keys **91** comprises a second elastic layer **92** made of transparent rubber material. A projection **93** is formed on the bottom of each second elastic layer **92** and passes through the through hole **101**.

[0052] When the light-emitting elements are lighted individually or selectively, the lights of different colors are guided by corresponding light guiding plates. Therefore, lights of different color pass through the surface of the keys **91**.

[0053] When the key **91** is pressed by external force, the projection **93** of the second elastic layer **92** passes through the aperture **62** and the through hole **101** and is then in contact with the metal plates **61**. Therefore, the metal plate **61** is in contact with a circuit board of the electronic device (not shown). The metal plate **61** also produces snap sound to provide tactile effect for user.

[0054] Although the present invention has been described with reference to the preferred embodiment thereof, it will be understood that the invention is not limited to the details thereof. Various substitutions and modifications have sug-

gested in the foregoing description, and other will occur to those of ordinary skill in the art. Therefore, all such substitutions and modifications are intended to be embraced within the scope of the invention as defined in the appended claims.

What is claimed is:

1. A multi-layer light guiding structure arranged in an electronic device and corresponding to keys and a plurality of light-emitting elements of the electronic device, the multi-layer light guiding structure comprising:

a plurality of light-guiding plates stacked together, a light-guiding strip formed on each of the light-guiding plates, the light-guiding strips being staggered to each other and corresponding to specific keys, wherein when each light-guiding plate guides light to the light-guiding strip, the light-guiding strip thereon is configured to refract light to corresponding key, whereby light of a specific color passes through a specific key.

2. The multi-layer light guiding structure as in claim **1**, wherein the light-guiding strip comprises a plurality of pits.

3. The multi-layer light guiding structure as in claim **1**, wherein the light-guiding strip comprises a color layer thereon.

4. The multi-layer light guiding structure as in claim **1**, further comprising a light block atop the light-guiding plate and the light-emitting element.

5. A multi-layer light guiding structure arranged in an electronic device and corresponding to keys and a plurality of light-emitting elements of the electronic device, the multi-layer light guiding structure comprising:

a light guiding structure comprising a plurality of light-guiding plates stacked together, a light-guiding strip formed on each of the light-guiding plates, the light-guiding strips being corresponding to each other, each of the light-guiding strips comprising a color layer;

a light block arranged between two adjacent light-guiding plates and two light-emitting elements,

wherein two light-guiding plates guide light to corresponding light-guiding strips, and the light-guiding strips refract light to a corresponding key, the light is filtered by the color layer, whereby light of a specific mixed color passes through the key.

6. The multi-layer light guiding structure as in claim **5**, wherein the light-guiding strip comprises a plurality of pits.

7. The multi-layer light guiding structure as in claim **5**, wherein the color layer of each of the light-guiding strips has different color.

8. A multi-layer light guiding structure arranged in an electronic device and corresponding to keys and a plurality of light-emitting elements of the electronic device, the multi-layer light guiding structure comprising:

a light guiding structure comprising a plurality of light-guiding plates stacked together, each of the light-guiding plates comprising a plurality of light-guiding areas, the light-guiding areas being staggered to each other and corresponding to alphabets and symbols of different orientations on the key; and

a plurality of light blocks, each arranged between two adjacent light-guiding plates and two light-emitting elements,

wherein when each light-guiding plate guides light to the light-guiding area, the light-guiding area thereon is configured to refract light to corresponding key, whereby light of a specific color passes through a specific key.

9. The multi-layer light guiding structure as in claim 8, wherein the light-guiding strip comprises a plurality of pits.

10. The multi-layer light guiding structure as in claim 8, wherein the light-guiding strip comprises a color layer thereon.

11. A method for using a multi-layer light guiding structure, the multi-layer light guiding structure arranged in an electronic device and corresponding to keys and a plurality of light-emitting elements of the electronic device, the method comprising:

- a). providing a plurality of stacked light-guiding plates;
- b). providing a light-emitting element corresponding to each of the light-guiding plates;
- c). providing light-guiding strips on each light-guiding plate, which are staggered to each other and corresponding to specific keys of the key module; and
- d). individually or selectively lighting the light-emitting elements and guiding in the light by the light-guiding plate, where the light-guiding strips change optical path of the light to refract the light to the specific keys.

12. The method as in claim 11, wherein the light-guiding strip comprises a plurality of pits.

13. The method as in claim 11, wherein the light-guiding strip comprises a color layer.

14. The method as in claim 11, wherein the multi-layer light guiding structure further comprises a light block between adjacent light-guiding plates and adjacent light-emitting elements.

15. A key module having a multi-layer light guiding structure, the multi-layer light guiding structure arranged in an electronic device and corresponding to a plurality of light-emitting elements, the key module comprising:

- a first elastic layer comprising a plurality of metal plates thereon;
- a light-guiding structure arranged on the first elastic layer and comprising a plurality of light-guiding plates, each of the light-guiding plates comprising at least one light-guiding strip and the light-guiding strips of different layer of light-guiding plates being staggered to each other and corresponding to specific keys, where a light block is provided between adjacent light-guiding plates and adjacent light-emitting elements;
- a second elastic layer arranged on the light-guiding structure; and
- a key module arranged on the second elastic layer and comprising a plurality of keys, each key corresponding to a projection.

16. The key module as in claim 15, wherein a binding layer is provided between the second elastic layer and the key module.

17. The key module as in claim 15, wherein the second elastic layer comprises a rubber body and a rigid plastic film on surface of the rubber body, the rubber body comprising a projection on bottom thereof.

18. The key module as in claim 15, wherein the light-guiding strip comprises a plurality of pits.

19. The key module as in claim 15, wherein the light-guiding strip comprises a color layer.

20. The key module as in claim 15, wherein the light-guiding structure comprises a plurality of light-guiding plates, each of the light-guiding plates comprises at least one light-guiding strip and the light-guiding strips are corresponding to respective keys, a color layer is provided for each light-guiding strip and a light block is arranged between two adjacent light-guiding plates and two light-emitting elements.

21. The key module as in claim 15, wherein the wherein the light-guiding structure comprises a plurality of light-guiding plates, each of the light-guiding plates comprises a plurality of light-guiding areas and the light-guiding areas are staggered to each other and corresponding to respective keys, a color layer is provided for each light-guiding area and a light block arranged between two adjacent light-guiding plates and two light-emitting elements.

22. A key module having a multi-layer light guiding structure, the multi-layer light guiding structure arranged in an electronic device and corresponding to a plurality of light-emitting elements, the key module comprising:

- a first elastic layer comprising a plurality of apertures and each aperture containing a metal plates therein;
- a light-guiding structure arranged on the first elastic layer and comprising a plurality of light-guiding plates stacked to each other, each of the light-guiding plates comprising at least one light-guiding strip and a plurality of through holes, the light-guiding strips of different layer of light-guiding plates being staggered to each other and corresponding to specific keys, where a light block is provided between adjacent light-guiding plates and adjacent light-emitting elements; and
- a key module arranged on the light-guiding structure and comprising a plurality of keys, the key comprising a second elastic layer and the second elastic layer comprising a projection passing through the through hole of each layer of light-guiding plate.

23. The key module as in claim 22, wherein the light-guiding strip comprises a plurality of pits.

24. The key module as in claim 22, wherein the light-guiding strip comprises a color layer.

25. The key module as in claim 22, wherein the light-guiding structure comprises a plurality of light-guiding plates, each of the light-guiding plates comprises at least one light-guiding strip and the light-guiding strips are corresponding to respective keys, a color layer is provided for each light-guiding strip and a light block is arranged between two adjacent light-guiding plates and two light-emitting elements.

26. The key module as in claim 22, wherein the wherein the light-guiding structure comprises a plurality of light-guiding plates, each of the light-guiding plates comprises a plurality of light-guiding areas and the light-guiding areas are staggered to each other and corresponding to respective keys, a color layer is provided for each light-guiding area and a light block arranged between two adjacent light-guiding plates and two light-emitting elements.

* * * * *