

No. 679,437.

Patented July 30, 1901.

E. A. STARK & T. WINSHIP.
FLUID PRESSURE ENGINE.

(Application filed Mar. 29, 1900.)

(No Model.)

4 Sheets—Sheet 1.

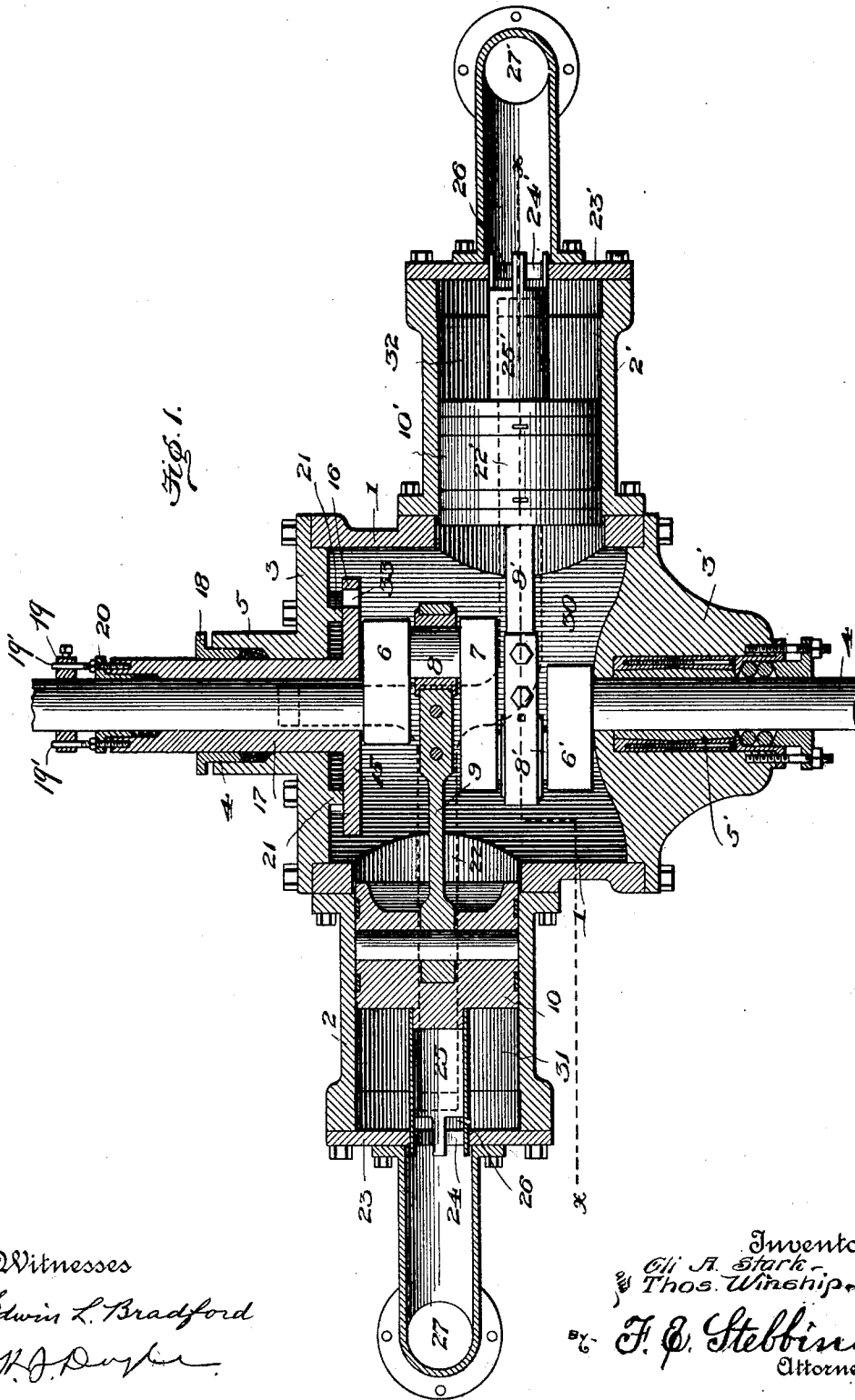

Fig. 1.

Witnesses
Edwin L. Bradford
H. J. Dwyer

Inventors
E. A. Stark
& T. Winship
By F. C. Stebbins
Attorney

No. 679,437.

Patented July 30, 1901.

E. A. STARK & T. WINSHIP.
FLUID PRESSURE ENGINE.

(No Model.)

(Application filed Mar. 29, 1900.)

4 Sheets—Sheet 2.

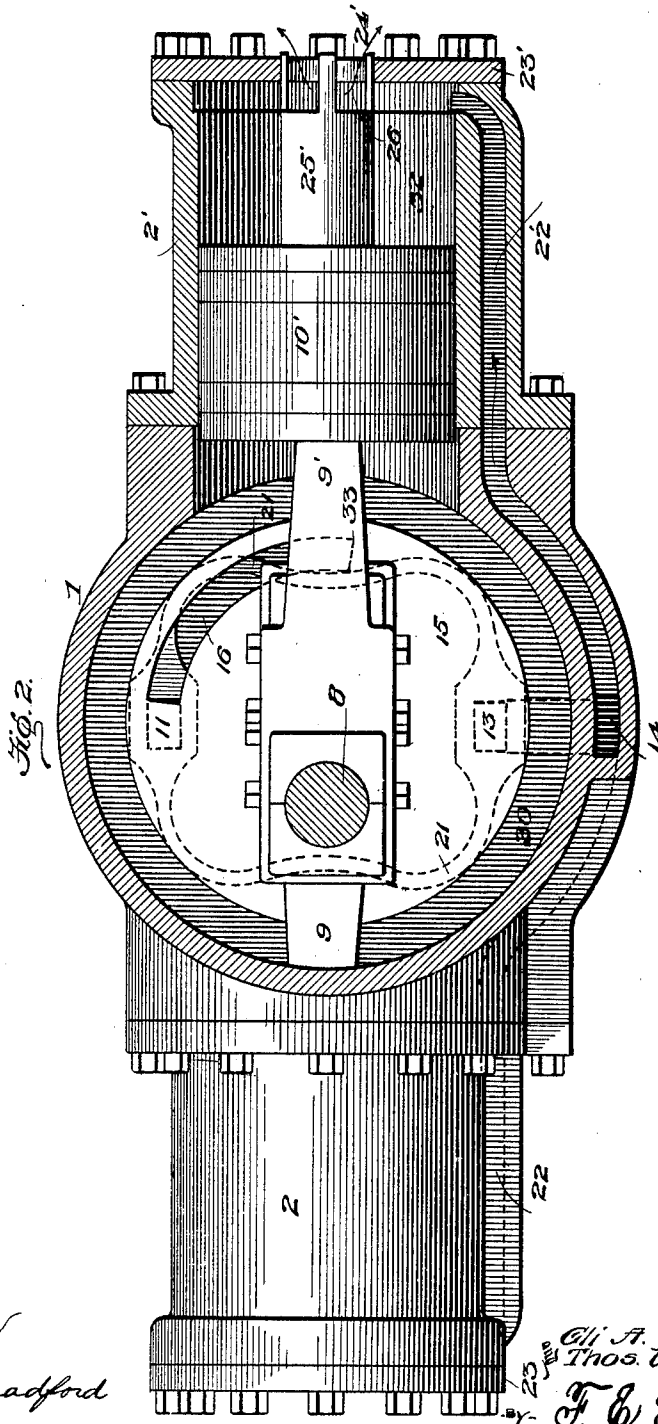

Witnesses
Edwin L. Bradford
H. J. Poyle

Inventors
Eli A. Stark
Thos. Winship
F. C. Stebbins
Attorney

No. 679,437.

Patented July 30, 1901.

E. A. STARK & T. WINSHIP.

FLUID PRESSURE ENGINE.

(Application filed Mar. 29, 1900.)

(No Model.)

4 Sheets—Sheet 3.

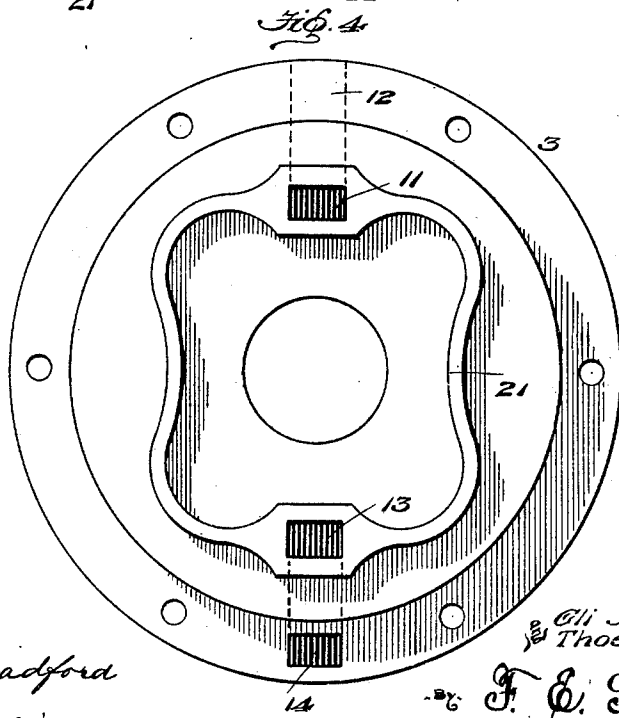
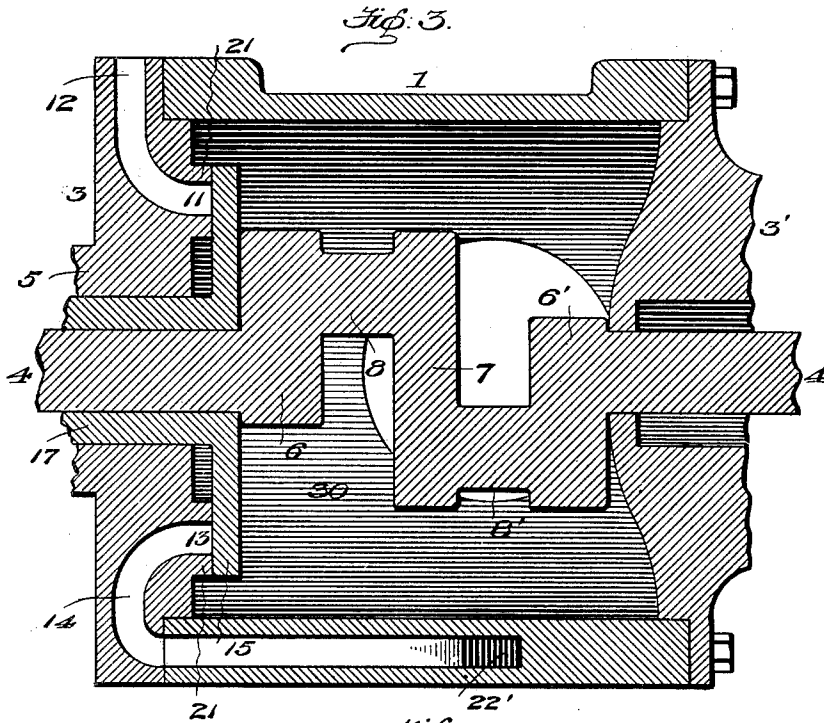

Witnesses
Edwin L. Bradford
H. J. Pope

Inventors
Eli S. Stark
& Thos. Winship
By J. E. Stebbins.
Attorney

No. 679,437.

Patented July 30, 1901.

E. A. STARK & T. WINSHIP.

FLUID PRESSURE ENGINE.

(Application filed Mar. 29, 1900.)

(No Model.)

4 Sheets—Sheet 4.

Fig. 5.

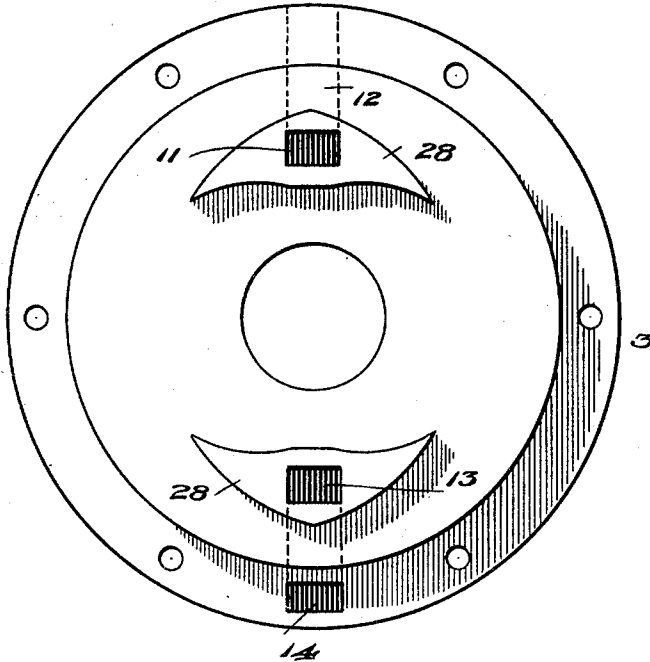
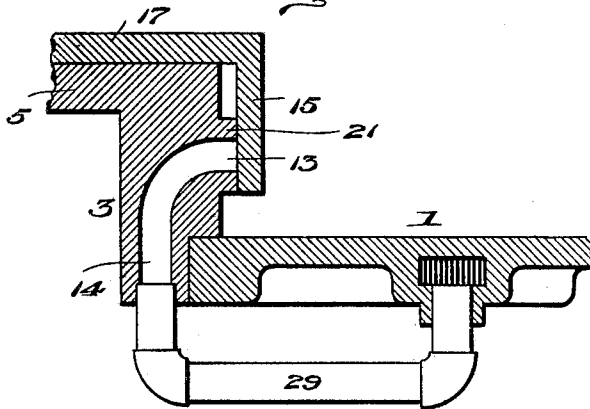

Fig. 6.



Witnesses

Edwin L. Bradford

St. J. Doyle

Inventors
E. A. Stark
& T. Winship

By

J. C. Stebbins
Attorney

UNITED STATES PATENT OFFICE.

ELI A. STARK AND THOMAS WINSHIP, OF TOLEDO, OHIO, ASSIGNORS TO
THE TOLEDO STEAM AND AIR MOTOR COMPANY.

FLUID-PRESSURE ENGINE.

SPECIFICATION forming part of Letters Patent No. 679,437, dated July 30, 1901.

Application filed March 29, 1900. Serial No. 10,654. (No model.)

To all whom it may concern:

Be it known that we, ELI A. STARK and THOMAS WINSHIP, citizens of the United States, residing at Toledo, in the county of Lucas and State of Ohio, have invented certain new and useful Improvements in Fluid-Pressure Engines, of which the following is a specification.

The object of our invention is the production of a fluid-pressure engine which shall be economical in the use of the motive fluid, which shall admit of the use of the motive fluid a second time, which shall use steam quickly and expansively when so desired and educt it and exhaust it rapidly so as to minimize the loss from condensation, which will not leak motive fluid, which shall have the reciprocating parts accurately balanced, thus adapting the engine for high speeds without excessive wear or vibration, which shall eliminate as far as possible friction of all the movable parts, and to that end dispense with the use of connecting-rods moving through stuffing-boxes, which shall be simple in construction, comparatively cheap in first cost, and, when necessary, easy to repair, and which, finally, shall be compact, suiting it for use within limited spaces or areas. To attain this object or end, we have devised an engine comprising, first, a cylinder, two pistons dividing the cylinder into three chambers, a rotary shaft projecting into the central part or chamber of the cylinder or extending through the same, two cranks, two pitmen, means for periodically admitting motive fluid into the central chamber, means for periodically educting motive fluid from the central chamber into the end chambers back of the pistons, and means whereby the motive fluid can finally be discharged directly from the end chambers; second, a cylinder, two pistons located within the cylinder and dividing it into three chambers, a rotary shaft projecting into the central chamber and provided with two cranks located approximately one hundred and eighty degrees each from the other, two pitmen uniting the pistons and cranks, means for periodically admitting motive fluid to the central chamber for the purpose of forcing the pistons apart, means for periodically educting the motive fluid from the central cham-

ber to the end chambers and back of the pistons, and means operated by the pistons for exhausting the motive fluid from the end chambers; third, a cylinder, two movable pistons located within the cylinder and dividing it into three chambers, a shaft located in the central chamber and adapted to rotate, means uniting the shaft and pistons which when the pistons are moved will give a rotary motion to the shaft, means operated by the shaft for periodically admitting motive fluid to corresponding sides of the pistons, means for periodically educting the motive fluid to the other corresponding sides of the pistons, and means for exhausting the motive fluid to the atmosphere; fourth, a cylinder, two pistons, a rotary shaft extending into or through the cylinder, two cranks, two pitmen, means within the central chamber operated by the shaft for periodically opening a port by which motive fluid is admitted to the central chamber, means for periodically educting motive fluid from the central chamber to the end chambers, and means for exhausting motive fluid from the end chambers; fifth, a cylinder, two pistons, a rotary shaft within the central chamber of the cylinder, two cranks, two pitmen, a rotary disk valve operated by the shaft and controlling the admission of motive fluid to the central chamber, means for educting motive fluid from the central chamber to the end chambers, and means for exhausting the motive fluid to the atmosphere; sixth, a cylinder, two pistons, a rotary shaft within the cylinder and having two cranks, two pitmen, means for periodically admitting motive fluid to the central chamber, a rotary disk valve operated by the shaft for periodically opening a port and educting motive fluid from the central chamber to the end chambers, and means for exhausting motive fluid from the end chambers; seventh, in combination with other elements a rotary valve controlling the motive-fluid-inlet port and having part of its body cut away or slotted; eighth, in combination with other elements a rotary valve controlling an eduction-port from the central chamber and having part of its circumference cut away or slotted; ninth, in combination with other elements a valve operated by a rotary shaft and control-

- ling the inlet and eduction ports of the central chamber; tenth, in combination with other elements a rotary shaft within the central chamber, means for periodically admitting motive fluid to the central chamber and using it expansively, and means for educting motive fluid from the central chamber to the end chambers; eleventh, in combination with other elements a rotary disk valve controlling the inlet and eduction ports of the central chamber, said valve being cut away or slotted in the shape of an arc approximately one-fourth or one-third of its circumference to admit motive fluid to the central chamber and to educt it therefrom; twelfth, in combination with other elements valves secured to the pistons and having bearings and movable at the ends or in the cylinder-heads for controlling the exhaustion of motive fluid from the end chambers, and, finally, an engine comprising and embracing certain novelties of construction and combinations of arrangements of parts, as hereinafter specified, and pointed out in the claims.
- 25 The accompanying drawings illustrate one example of the physical embodiment of our invention and two modifications of specific parts thereof constructed according to the best of the several modes or ways which we have so far devised for applying the principle.
- 30 Figure 1 is a horizontal sectional view of the said example, showing the relative positions of the exhaust-valves, the rotary valve, pitmen, and other elements as they appear when the pistons are at the ends of their strokes. Fig. 2 is a sectional view of Fig. 1, taken in a plane on the line *x x* passing through the central chamber and one of the end chambers, but showing the piston in elevation. Fig. 3 is a sectional view of Fig. 1, taken in a perpendicular plane on line *y y* passing through the central chamber, the side castings, and the rotary valve. Fig. 4 is a view in elevation of one of the side castings, showing the ports and the tortuous boss against which the rotary valve fits. Fig. 5 is a view in elevation of one of the side castings, showing the ports and a modified form of the boss or bearing-surface for the rotary valve. Fig. 6 is a view of a modified form of means for uniting the eduction-passage in the side casting and the eduction-passages to the end chambers.
- 55 Referring to the views, the cylinder proper is shown in this instance composed of five main parts or castings united by bolts. The numeral 1 designates a central casting of irregular shape.
- 60 2 2' are end castings, each made with a central longitudinal and circular passage or bore for the reception of a piston.
- 3 3' are side castings.
- 4 is a rotary shaft; 5, a bearing for the shaft and rotary valve located within a longitudinal passage made through one of the side castings; 5', a bearing for the shaft in the opposite side casting.
- 6 6' are crank-arms.
- 7 is a double-crank arm or coupling. 70
- 8 8 are crank-pins integral with or secured to the ends of the arms 6 6' and the opposite ends of the double-crank arm or coupling.
- 9 9' are pitmen.
- 10 10' are pistons to which the pitmen are pivoted, as shown. 75
- 11 is the motive-fluid-inlet port to the central chamber.
- 12 is a motive-fluid-inlet passage made in the casting 3, as shown; 13, the motive-fluid-eduction port from the central chamber; 14, a motive-fluid-eduction passage made in the casting, as shown; 15, a rotary valve which controls the inlet and eduction ports. 80
- 16 designates a slot in the rotary valve. 85
- 17 is the sleeve or cylindrical part of the rotary valve, which fits loosely over the shaft and frictionally engages bearing 5, as illustrated.
- 18 is a packing-ring; 19, a collar and set-screw. 90
- 19' represents pins secured in the sleeve and loosely engaging the collar.
- 20 is a packing-ring; 21, a tortuous boss or side bearing on the side casting. 95
- 22 22' are eduction-passages (shown in dotted lines, Figs. 1 and 2) leading from the central chamber by way of the eduction-port 13 to the chambers back of the pistons; 23 23', the cylinder-heads secured to the ends of the cylinder by bolts. 100
- 24 24' are circular holes through the cylinder-heads; 25 25', exhaust-valves, each consisting of a metallic tube secured at one end to a piston in any desirable way, as shown at the right in Fig. 2, and at the free end closely fitting and movable within a circular hole made in a cylinder-head. 105
- 26 designates notches made in the free ends of the tubes and substantially of the shape illustrated. 110
- 27 27' are exhaust-motive-fluid-conducting pipes.
- In Fig. 5 we have shown a modified form of boss 28 on the side casting for the bearing of the rotary valve. Each boss is of the shape illustrated, which insures an even wear of the rotary valve and a close fit at all times. 115
- In Fig. 6 the eduction-passages from the central chamber to the end chambers are not made entirely within the body of the castings, as in Fig. 3, but the eduction-passage 14 and the eduction-passages 22 22' are united by a pipe 29, which is located outside the central casting. 120
- 125 It will be observed that the two pistons divide the interior of the cylinder proper into a central chamber 30 and two end chambers 31 32, that the rotary shaft extends through the central chamber, and that the pitmen and cranks are located entirely within said central chamber, and, further, that the length 130

of the curved slot or opening 16 in the rotary valve in this example is about one-fourth of the entire circumference of a circle passing through the inlet and eduction ports, though it may be one-half of the circumference or less under certain conditions. When the length of the slot approximates one-fourth or one-third of the circumference of the valve, more or less, it is obvious that motive fluid will be admitted to the central chamber and act upon the pistons with full pressure only during a fraction of their outward strokes and that therefore when the inlet-port has been closed the motive fluid will act expansively to complete the outward strokes.

The length of the slot 16 in the rotary valve should be in all cases such that the eduction-port 13 will commence to open the instant the pitmen have passed the dead-centers and the pistons have commenced their instrokes and that the eduction-port will be closed before or when the pistons approximately complete their instrokes. However, the relation of the period of eduction to the period of exhaustion by way of the valves 25 25' is such that the slot 16 in the valve must be less than half the circumference of the disk.

The shape of the tortuous boss 21 on the face of the side casting 3 has been devised to insure a continuous bearing-surface, an even wear of the valve and boss, and consequently a close fit at all times, and to permit entrance of the steam by slot 16 to the back of the valve, and thus balance it, as shown by Fig. 2. Motive fluid can pass back of the valve four times during each revolution of the valve. The set-screw in the collar allows the adjustment of the sleeve about the shaft, and the pins loosely engaging the collar permit the sleeve to move longitudinally and compensate for expansion.

The *modus operandi* of the engine is as follows: The several movable parts being in the positions shown in Figs. 1 and 2, which represent the pistons at the ends of their instrokes, a slight rotation of the shaft and valve in the direction of the arrow carries the pitmen beyond the dead-centers and opens the inlet-port 11, (see Fig. 2,) which remains open till the point 33 of the slot passes beyond the port, which action shuts off the admission of the motive fluid. Inasmuch as the slot is only one-fourth of the arc of a circle the port 11 will be closed when the pistons have traveled about one-half of the outstrokes. During the period intervening between the closing of the port 11 and the opening of the eduction-port 13 by the slot 16 the pistons will be acted upon and their outward strokes completed by the motive fluid acting expansively. As the pistons approach the ends of their outward strokes the valves 25 25' close the exhaust-openings from the end chambers, as is obvious. When the port 13 is opened, motive fluid from the central chamber passes by way of the eduction-con-

duits to the now closed end chambers 31 32 back of the pistons, the eduction-port remaining open till the end 33 of the slot in the rotary valve has passed the same, at which time the pistons may have approximately completed one-half their instrokes and also have commenced to open the exhaust-valves 25 25'; but the length of the slot 16 will of course in all cases determine the period of eduction.

The paths traversed by the motive fluid from the inlet-port 11 to the exhaust-fluid-conducting pipes 27 27' are shown by arrows in the figures.

The modes of operation which would accompany changes in the length of the slot in the rotary valve would obviously be of a nature substantially the same as above set forth, varying mainly in degree.

From the foregoing description of the construction and mode of operation of the pictured example it will be seen that we have produced an engine adapted to be operated by a motive fluid and which fulfils all the conditions hereinbefore set forth as the object or purpose of our invention.

As regards our method of using the motive fluid a second time it has been proven by actual tests that the eduction of motive fluid after it has acted upon corresponding ends of the pistons to the other corresponding ends is attended with characteristic and very desirable results. Furthermore, when the motive fluid is used expansively in the central chamber there is an increased economy in the use of steam and a corresponding saving of fuel.

While we have illustrated and described only one example of the physical embodiment of our invention and two modifications of specific details, we do not thereby intend to limit its scope to this particular example or mode of embodiment or to the modifications, inasmuch as the principle can be applied in other ways and by other modes not involving a substantial departure.

The general way of constructing the engine and the provision of valve mechanism which allows the eduction of the motive fluid after its energy has been partially utilized, either at full pressure or by acting expansively on the opposite sides of the pistons to corresponding opposite sides of the same pistons and finally to the atmosphere, are among the essential features of our invention. The details of construction, however, to accomplish the desired mode of operation may of course be varied and equivalents substituted for the several elements illustrated. For example, in lieu of making the cylinder proper of five main parts and uniting them by bolts we may form the central and end castings integral or in any other way, the pistons may be located in line instead of offset, eduction-passages entirely separate from the cylinder may be employed, removable or supplemental bearings may be provided for the exhaust

- valves in the cylinder heads, the shape of the rotary valve altered and its location changed, the length of the slot in the valve increased or diminished, the area of the bearing-surface of the valve against the boss or bosses or inner surface of the central casting diminished or increased, and the exhaust-valves at the ends of the cylinder re-formed or differently arranged.
- Such and many other changes in construction, modifications, substitutions, and incorporations we intend to embrace within the scope of the claims.
- What we claim is—
1. An engine having a cylinder; two pistons dividing the interior of the cylinder into three chambers; a rotary shaft; means for transforming the reciprocating motion of the pistons to the rotary shaft; a valve-seat; an inlet-port for the admission of motive fluid to the central chamber; an eduction-port and passages from the central chamber to the end chambers; a valve frictionally engaging the valve-seat and controlling the inlet and eduction ports; and means for exhausting the motive fluid from the end chambers; whereby the motive fluid can first be admitted to the central chamber, then educted to the end chambers, and finally exhausted.
 2. An engine having a cylinder provided with an inlet-port for the motive fluid; two pistons dividing the interior of the cylinder into three chambers; a rotary shaft in the central chamber; two pitmen; means uniting the pitmen and rotary shaft; an eduction-port and passages from the central chamber to the end chambers; a valve-seat in which the inlet and eduction ports are located; a rotary valve on the rotary shaft, engaging the seat, and controlling the inlet and eduction ports; and means for exhausting the motive fluid from the end chambers.
 3. An engine having a cylinder provided with an inlet-port for the motive fluid; two pistons dividing the interior of the cylinder into three chambers; a rotary shaft in the central chamber; two pitmen; means uniting the pitmen and rotary shaft; an eduction-port and passages from the central chamber to the end chambers; a valve-seat; a rotary valve located in the central chamber, operated by the shaft, engaging the valve-seat, and controlling the inlet and eduction ports; and means for exhausting motive fluid from the end chambers.
 4. An engine having a cylinder provided with an inlet-port for the motive fluid; two pistons dividing the interior of the cylinder into three chambers; a rotary shaft in the central chamber; two pitmen; means uniting the pitmen and shaft; an eduction-port and passages from the central chamber to the end chambers; a rotary valve adjustable on the shaft and controlling the inlet and eduction ports; and means for exhausting motive fluid from the end chambers.
 5. The combination in an engine in which the motive fluid is first admitted to a central chamber, then educted to two end chambers, and finally exhausted to the atmosphere, of a cylinder having inlet and eduction ports and passages from the central chamber to the end chambers; a rotary shaft in the central chamber; a valve-seat; and a rotary valve fitting the seat, operated by the shaft, and controlling the inlet and eduction ports; said rotary valve being slotted or cut away to afford a passage for motive fluid to and from the central chamber.
 6. The combination in an engine in which the motive fluid is first admitted to a central chamber, then educted to two end chambers, and finally exhausted to the atmosphere, of a cylinder having inlet and eduction ports and passages from the central chamber to the end chambers; a rotary shaft in the central chamber; and a valve for controlling the inlet and eduction ports; said valve comprising a disk portion bearing against a valve-seat and a cylindrical portion mounted on the shaft.
 7. The combination in an engine in which the motive fluid is first admitted to a central chamber, then educted to two end chambers and finally exhausted to the atmosphere, of a cylinder having inlet and eduction ports and passages from the central chamber to the end chambers; a rotary shaft in the central chamber; and a valve fitting a valve-seat and controlling the inlet and eduction ports; said valve being mounted upon the shaft and adjustable longitudinally upon and also about the axis of the shaft.
 8. An engine having a cylinder provided with an inlet-port for the motive fluid; two pistons dividing the interior of the cylinder into three chambers; a rotary shaft; two pitmen; means uniting the pitmen and shaft; a valve controlling the inlet-port and which admits motive fluid only during a part of the period of the outward traverse of the two pistons; an eduction-port and passages from the central chamber to the end chambers; means for periodically opening and closing the eduction-port; and means for exhausting the motive fluid from the end chambers.
 9. The combination in an engine in which the motive fluid is first admitted to a central chamber, then educted to two end chambers, and finally exhausted to the atmosphere; of a cylinder having inlet and eduction ports and passages from the central chamber to the end chambers; a rotary shaft in the central chamber; and a valve for controlling the inlet and eduction ports; the said valve being cut away or slotted in the shape of an arc of a circle for a distance less than half the circumference of the valve measured by a circle described by a radius extending from the center of the shaft to the inlet-port; whereby motive fluid can be used expansively in the central chamber of the engine.
 10. An engine having a cylinder provided

with an inlet-port for the motive fluid; two pistons dividing the interior of the cylinder into three chambers; a rotary shaft in the central chamber; means for transforming the reciprocating motions of the pistons to the rotary shaft; an eduction-port and passages from the central chamber to the end chambers; means for controlling the admission of the motive fluid to and its eduction from the central chamber consisting of a valve fitting a valve-seat; and means operated by the pistons for exhausting the motive fluid from the end chambers.

11. An engine having a cylinder provided with an inlet-port for the motive fluid; two pistons dividing the interior of the cylinder into three chambers; a rotary shaft in the central chamber; two pitmen; means uniting the pitmen and rotary shaft; an eduction-port and passages from the central chamber to the end chambers; a valve-seat; a rotary valve engaging the seat and operated by the shaft; and valves operated by the pistons, each valve having an open passage in a part of its length for exhausting motive fluid from the end chambers.

12. The combination in an engine having a cylinder provided with an inlet-port for the motive fluid, of two pistons dividing the interior of the cylinder into three chambers; a rotary shaft in the central chamber; two pitmen; means uniting the pitmen and rotary shaft; an eduction-port and passages from the central chamber to the end chambers; a valve-seat having a boss; and a valve operated by a rotary shaft and controlling the inlet and eduction ports, said valve bearing against the boss in which the inlet and eduction ports are located.

13. An engine having a cylinder provided with an inlet-port for the motive fluid; two pistons dividing the interior of the cylinder into three chambers; a rotary shaft in the central chamber; two pitmen; means uniting the pitmen and rotary shaft; an eduction-port and passages from the central chamber to the end chambers; a side casting having bosses in which the inlet and eduction ports are located; and a rotary valve bearing against the bosses.

14. An engine having a cylinder provided with an inlet-port for the motive fluid; two pistons dividing the interior of the cylinder into three chambers; a rotary shaft in the central chamber; two pitmen; means uniting the pitmen and rotary shaft; an eduction-port and passages from the central chamber to the end chambers; and a valve operated by a rotary shaft and controlling the inlet and eduction ports; said valve bearing against

a tortuous boss in which the inlet and eduction ports are located.

15. An engine having a cylinder provided with inlet and eduction ports; a rotary shaft; two pistons; two pitmen; means uniting the pitmen and shaft; two passages leading from a central chamber to two end chambers; means for controlling the admission of motive fluid through the inlet-port; a valve located within the central chamber which controls the eduction-port; and valves operated by the pistons for exhausting the motive fluid from the end chambers.

16. An engine having a cylinder provided with an inlet-port for the motive fluid; two pistons dividing the interior of the cylinder into three chambers; a rotary shaft in the central chamber; two pitmen; means uniting the pitmen and rotary shaft; an eduction-port and passages from the central chamber to the end chambers; a casting in which the inlet and eduction ports are located; a rotary valve in contact with the inner surface of the casting, said valve operated by the shaft; and means carried by the pistons and engaging bearings in the cylinder-heads for exhausting motive fluid from the end chambers.

17. The combination in an engine in which the motive fluid is first admitted to a central chamber, then educted to two end chambers and finally exhausted to the atmosphere, of two pistons; a rotary shaft; means uniting the pistons and shaft; means for introducing motive fluid to the central chamber and educting it to the end chambers by two passages; and tubes secured to the pistons and notched or slotted at the ends, said tubes reciprocating within bearings made in the cylinder-heads.

18. The combination in an engine having a cylinder provided with an inlet-port for the motive fluid, of two pistons dividing the interior of the cylinder into three chambers; a rotary shaft in the central chamber; means for transmitting the reciprocating motion of the pistons to the rotary shaft; an eduction-port and passages from the central chamber to the end chambers; a valve-seat within which the inlet and eduction ports are located; a disk valve frictionally engaging the valve-seat and operated by the shaft; and valves operated by the pistons for simultaneously exhausting motive fluid from the end chambers.

ELI A. STARK.
THOMAS WINSHIP.

Witnesses:

O. P. BOWMAN,
CHAS. F. SEARLES.