



US 20040232026A1

(19) **United States**

(12) **Patent Application Publication**  
**Goeking et al.**

(10) **Pub. No.: US 2004/0232026 A1**

(43) **Pub. Date: Nov. 25, 2004**

(54) **MICROWAVEABLE FOOD STORAGE  
CONTAINER WITH FRESHNESS  
INDICATOR AND STEAM VENT**

(52) **U.S. Cl. .... 206/459.1**

(76) Inventors: **Harold J. Goeking**, Oshkosh, WI (US);  
**Carl R. Thompson**, Westport, CT (US);  
**Joseph M. Paul**, Thomaston, CT (US)

(57) **ABSTRACT**

Correspondence Address:  
**FERRELLS, PLLC**  
**P. O. BOX 312**  
**CLIFTON, VA 20124-1706 (US)**

A microwaveable food storage container including a unitary base having a generally planar bottom portion and a sidewall extending generally upwardly therefrom, the sidewall of the base including base sealing means for cooperating with a lid to form a seal; an injection-molded lid provided with resettable freshness indicator means at least in part integrally formed with the lid; a resealable vent preferably with a hinged vent panel integrally formed in the lid; and lid sealing means for cooperating with the base sealing means to form an annular interference-fit seal when the lid and base are joined. Preferably the base is an injection-molded base formed from a polypropylene resin such as isotactic polypropylene. In other embodiments, the polypropylene resin composition comprises a propylene/ethylene copolymer. Preferably, the base has a chamfered guide shoulder as well as an inwardly projecting annular sealing protuberance at the upper sidewall to define a notch wherein a sealing band in the lid is wedged when the base and lid are joined to form a closed container.

(21) Appl. No.: **10/796,924**

(22) Filed: **Mar. 10, 2004**

**Related U.S. Application Data**

(60) Provisional application No. 60/454,230, filed on Mar. 13, 2003. Provisional application No. 60/454,268, filed on Mar. 13, 2003.

**Publication Classification**

(51) **Int. Cl.<sup>7</sup> ..... B65D 85/00**

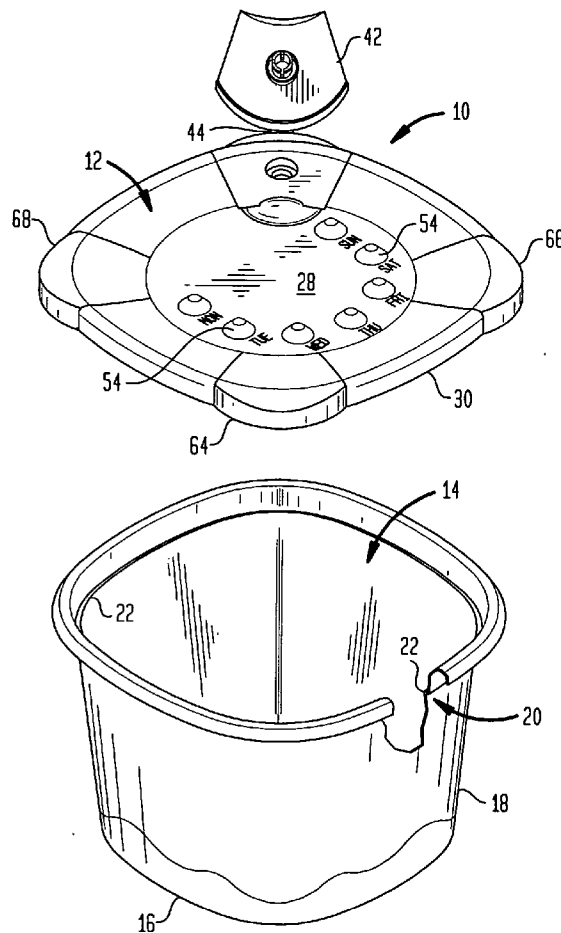

FIG. 1

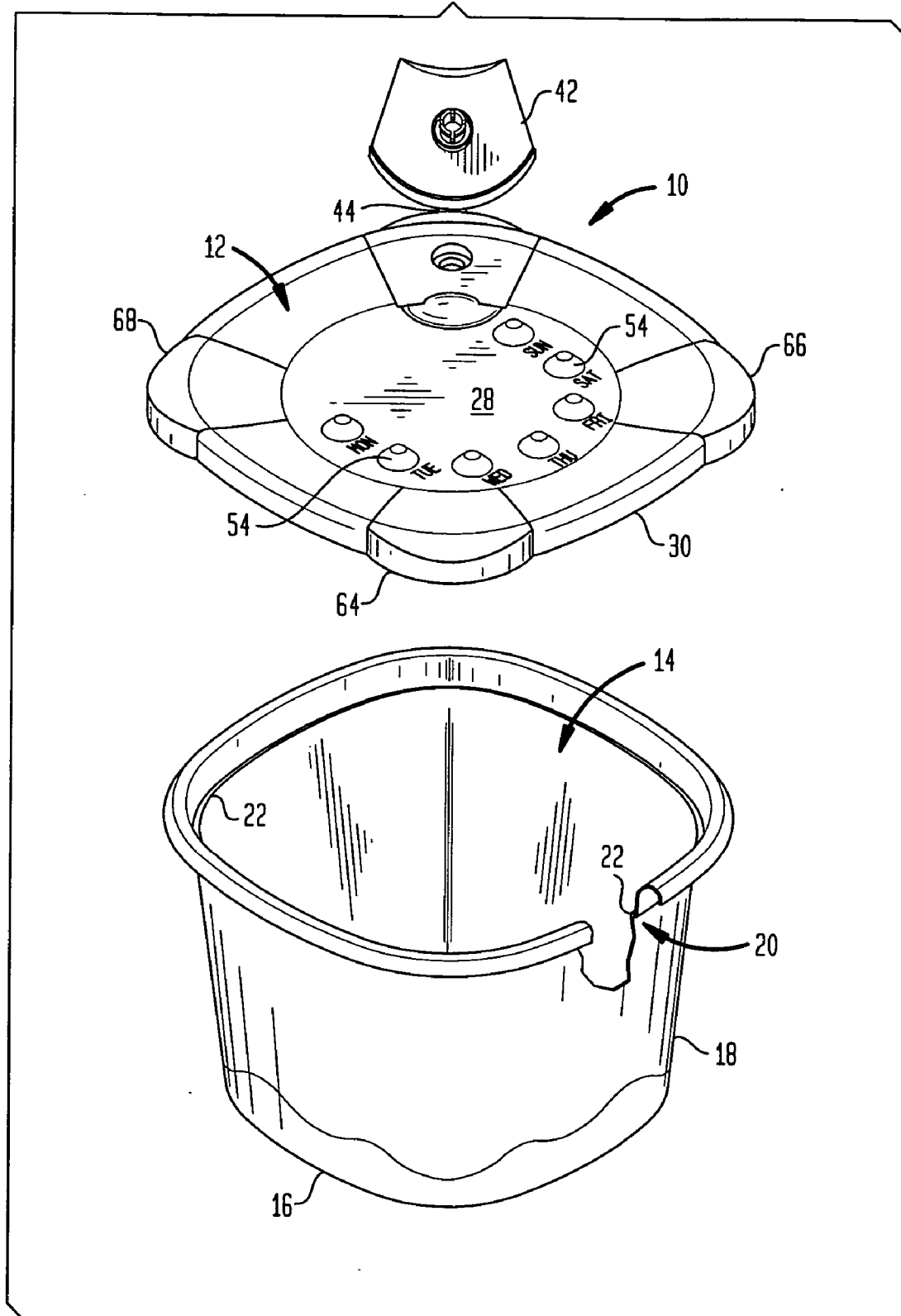

FIG. 2

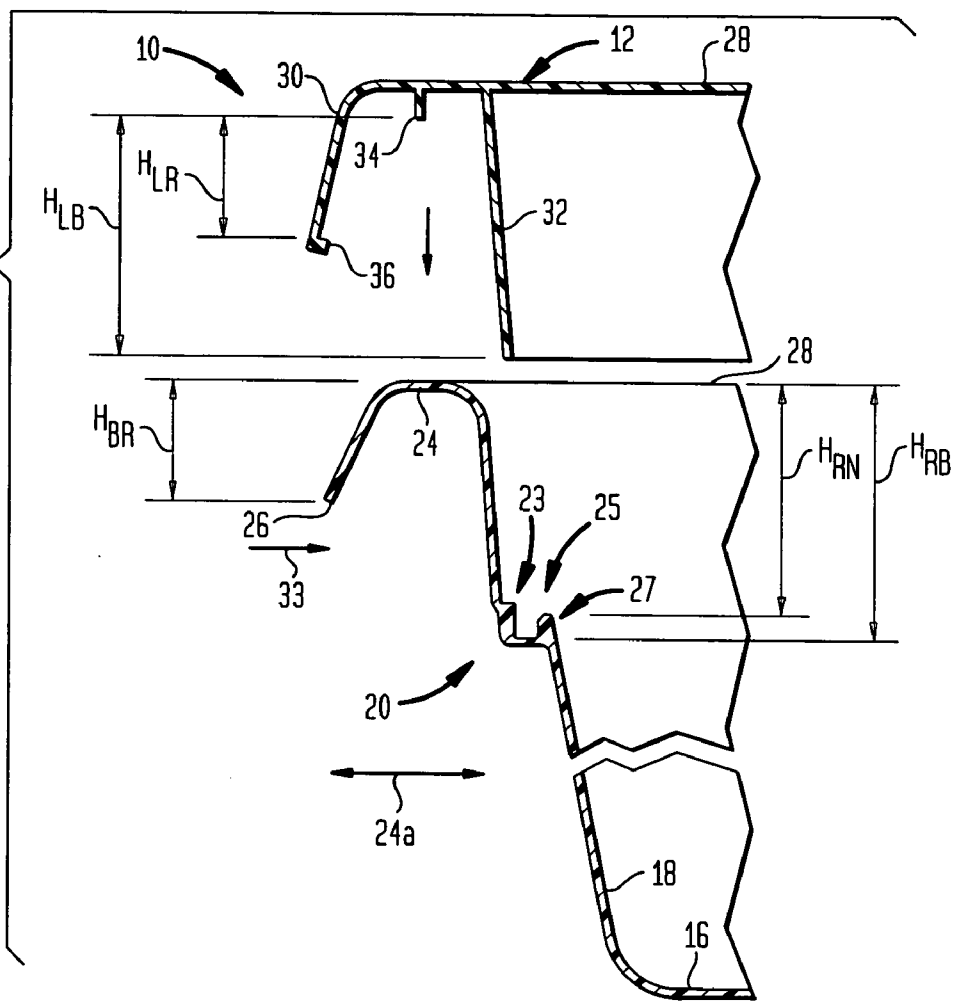
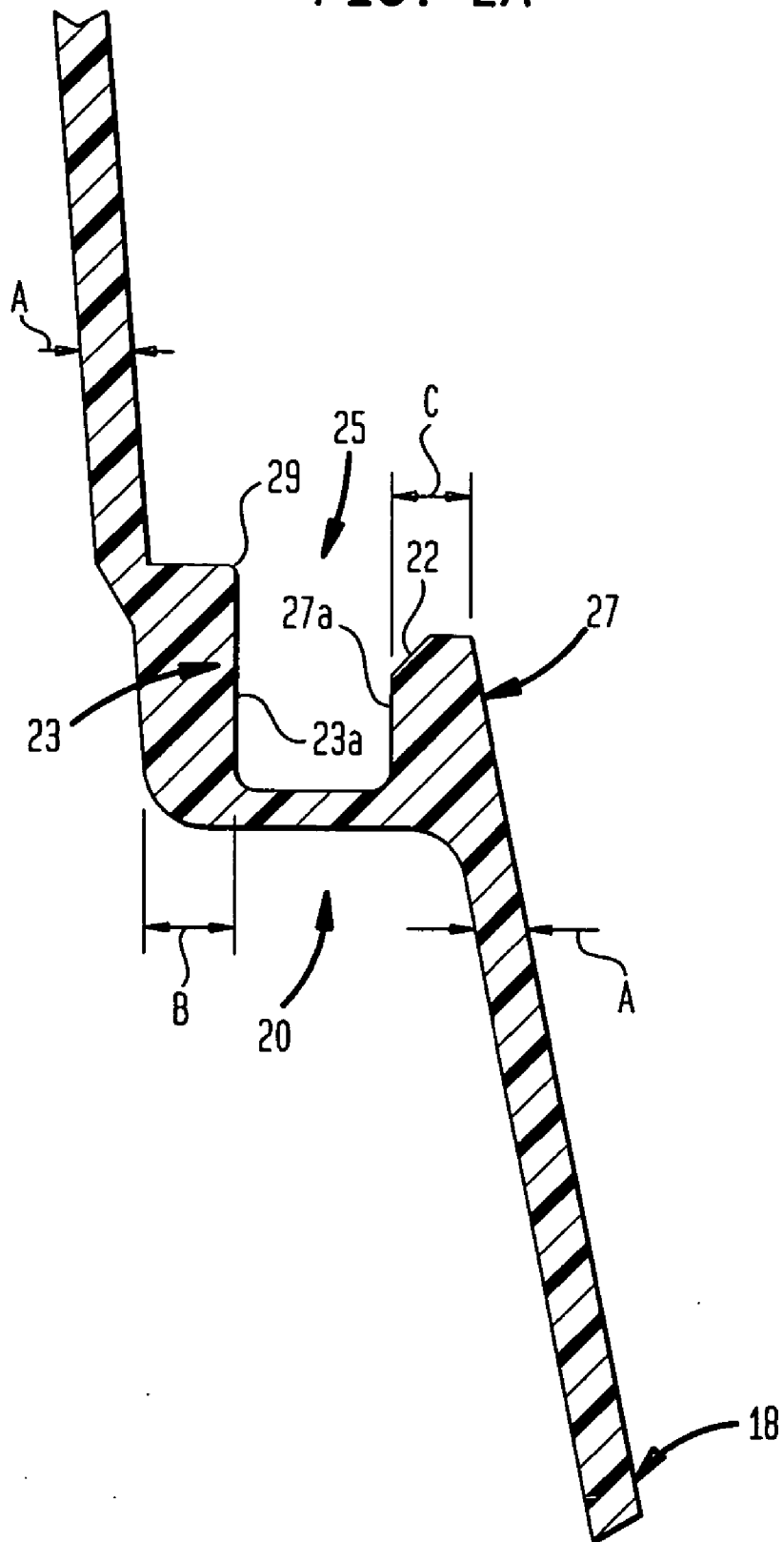

FIG. 2A



**FIG. 3**

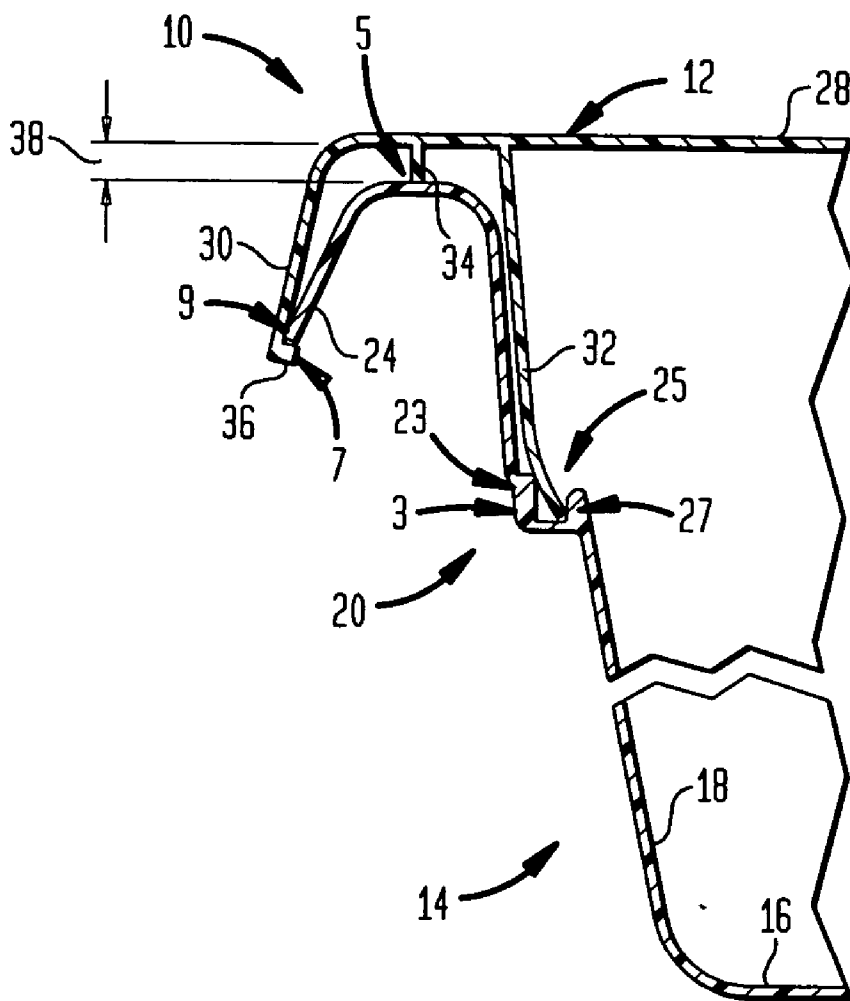
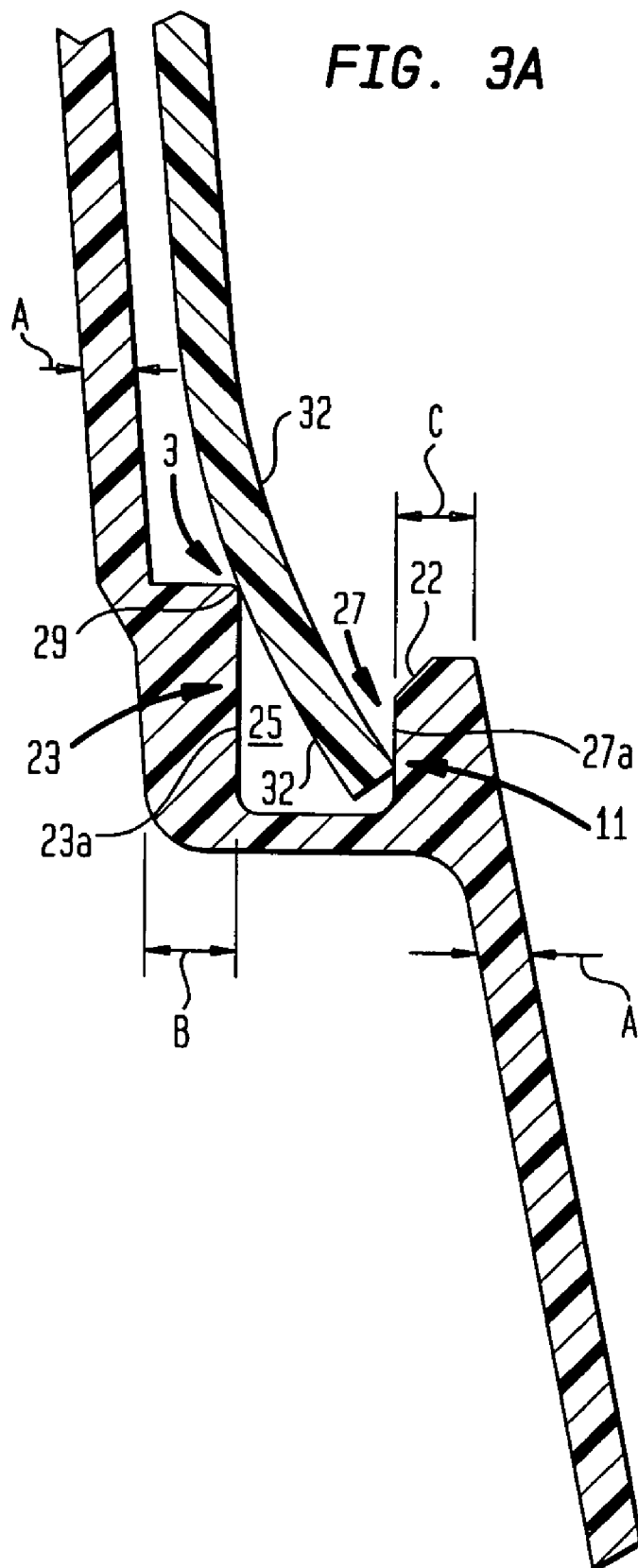

FIG. 3A



**FIG. 4**

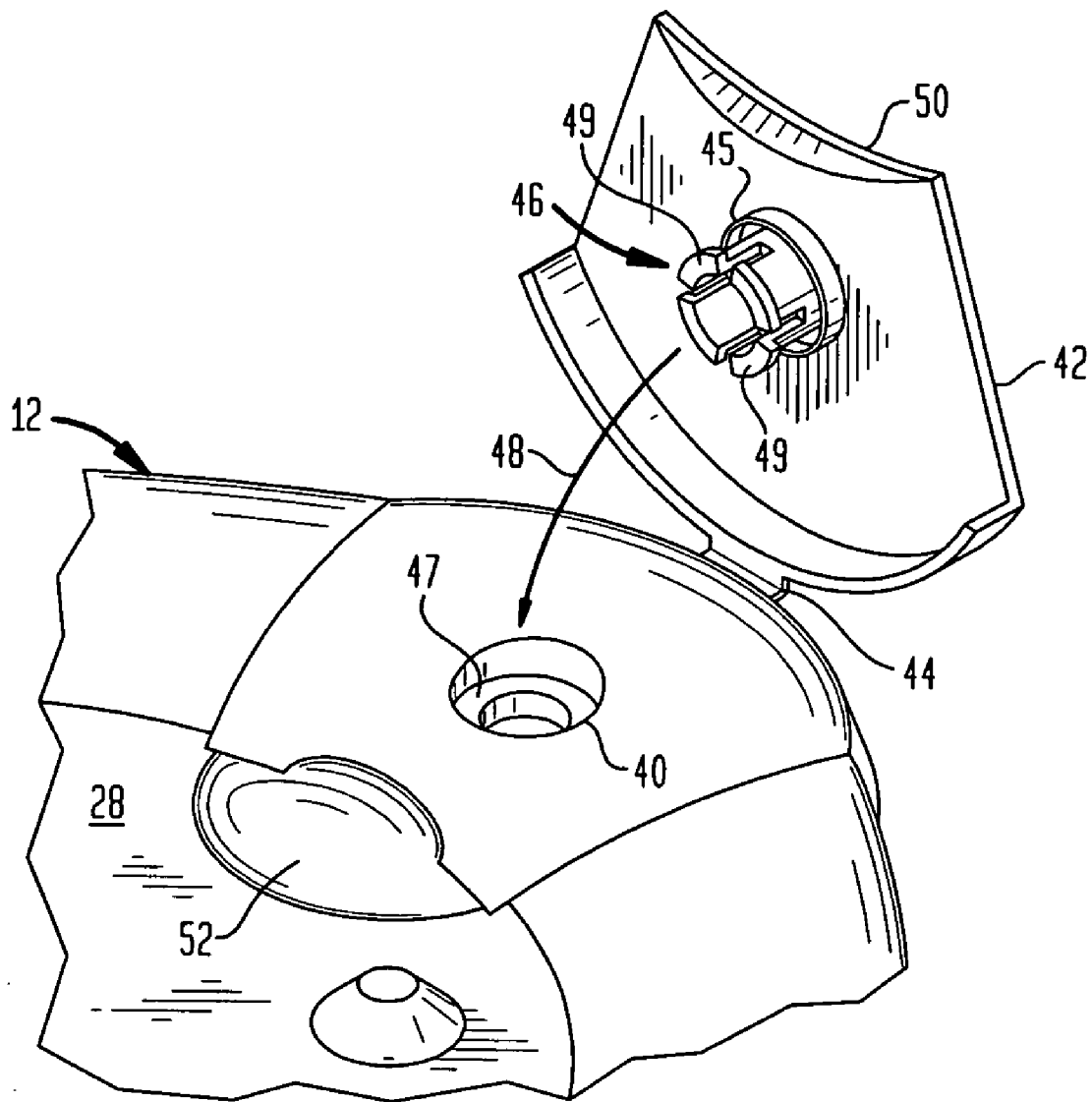
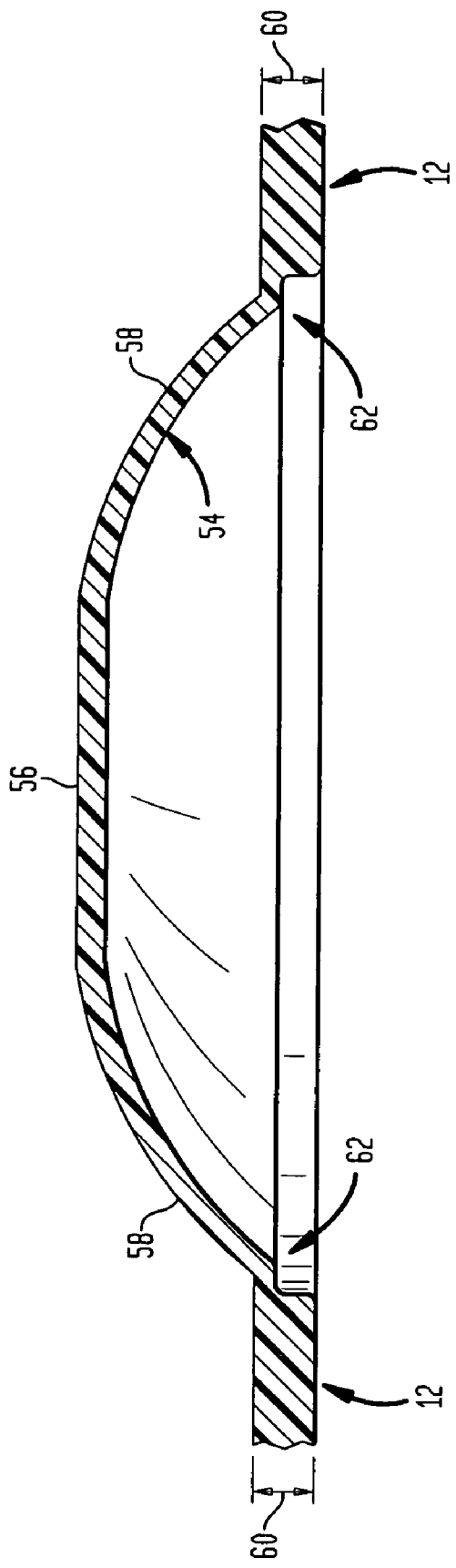

FIG. 5





**MICROWAVEABLE FOOD STORAGE CONTAINER  
WITH FRESHNESS INDICATOR AND STEAM  
VENT**

**CLAIM FOR PRIORITY**

[0001] This non-provisional application claims the benefit of the filing dates of U.S. Provisional Patent Applications Ser. Nos. 60/454,230 and 60/454,268, both filed on Mar. 13, 2003.

**TECHNICAL FIELD**

[0002] The present invention relates generally to food storage containers and more particularly to a food storage container having a lid and base with sealable portions operable to form an interference-fit seal as well as a lid vent and freshness indicators.

**BACKGROUND**

[0003] Food storage containers as well as containers with lids and bases having deformable interlocking rims are well known in the art. Such containers may include stacking shoulders as is seen, for example, in U.S. Pat. No. 6,467,647 to Tucker et al. as well as U.S. Pat. No. 6,170,696 also to Tucker et al. The '647 and 696 patents are directed to plastic containers including a lid and base wherein the rim of the lid and rim of the base have cut back portions around their periphery to form at least two continuous seals around the periphery of the container. So also, there is shown in U.S. Pat. No. 6,460,716 to Wong a plastic container including a lid and a base each of which has a flange and an inverted U-shaped rim. The flanges and rims mate to form four seals. A large horizontal seal is provided and two air pockets between seals allow for easy opening.

[0004] U.S. Pat. No. 6,196,404 to Chen shows a container with a lid and base which form a series of three self reinforcing seals. A protrusion on the lid reinforces the triple seal between the lid and base by applying force to the base, locking the lid and base together.

[0005] In U.S. Pat. No. 6,168,044 to Zettle et al. there is disclosed a resilient microwaveable container including a bowl and a detachable snap on lid. The lid includes a plurality of protrusions which snap over a pair of annular flanges extending outwardly from the bowl whereby a distinct clicking sound can be heard to verify the lid is properly attached.

[0006] In U.S. Pat. No. 6,056,138 to Chen there is disclosed a triple seal container including both a base and a lid. The base is a unitary component including a bottom portion attached to an upwardly extending perimeter wall which is further connected to a peripherally extending rim having an inner and outer edge. The lid also consists of a unitary component with a downwardly extending wall which is connected to a peripherally extending rim also having an inner and outer edge. Upon contact, the edges of the rims form three main seals.

[0007] Numerous means have been employed to form rim seals between lids and bases of containers. For example, there is seen in U.S. Pat. No. 6,260,729 to Mitchell et al. a highly elastic sealing cover for covering food containers or dishes which includes an accordion like construction so as to be adaptable to a variety of bases.

[0008] In U.S. Pat. No. 6,021,917 to Lovell et al. there is disclosed a plastic lid for a pail. The lid has a substantially planar central section and a peripheral channel. The channel fits over the pail to effect closure thereof. The central section is spaced from the channel by a groove and a ridge each of which extend around the lid juxtaposed to the channel with a groove being adjacent to the channel. Another pail/lid combination is seen in U.S. Pat. No. 5,328,047 to Smith. In the '047 patent there is disclosed a double locking cover which has a substantially J-shaped locking tip which fits into locking engagements with a ring on the pail.

[0009] U.S. Pat. No. 5,377,860 to Littlejohn et al. discloses a food container which is a combination of base portion and a lid portion made from resilient polymeric material. The base is a unitary component including an upwardly projecting peripherally extending sealing rim having inner and outer sealing regions. The lid is also a unitary component including a peripherally extending sealing channel correspondingly shaped to receive the sealing rim of the base and particularly to engage the rim at the inner and outer sealing areas.

[0010] In addition to sealing rims, various features have been incorporated into food sealing containers such as vents, freshness indicators and the like. As to vents the following art is representative: U.S. Pat. No. 6,305,546 to Saunders et al.; U.S. Pat. No. 5,780,824 to Matos; U.S. Pat. No. 5,750,967 to Sprauer, Jr.; U.S. Pat. No. 5,039,001 to Kinigakis et al.; U.S. Pat. No. Re. 32,739 to Terauds; U.S. Pat. No. 4,261,504 to Cowan; U.S. Pat. No. 4,574,174 to McGonigle; and U.S. Pat. No. 3,873,735 to Chalin et al.

[0011] Indicators for identifying container contents and/or freshness indicators for containers are known in the art. There is shown for example in U.S. Pat. No. 3,974,916 to Bartolucci a cup cover with a plurality of raised, dome-shaped portions each of which is capable of manual ever-sion. Visible indicia associated with each raised portion and identifying a variety of contents which can be placed in the cup around the raised dome-shaped portions. Manual ever-sion of a selected raised portion thus alters the appearance of the portion to provide a visual indication of the identity of the particular contents of the cup. Other containers associated with identifying indicia are shown in the following patents: U.S. Pat. No. 5,642,605 to Tenner et al.; U.S. Pat. No. 5,790,718 also to Tenner et al.; U.S. Pat. No. 5,839,581 to Vagedes; U.S. Pat. No. 4,762,248 to Uhlig; and U.S. Pat. No. 3,818,858 to Kramer et al. See, also, U.S. patent application Ser. No. 09/277,270 of Ferretti et al., filed Mar. 26, 1999.

**SUMMARY OF INVENTION**

[0012] There is provided in accordance with the invention a microwaveable food storage container including a unitary base having a generally planar bottom portion and a sidewall extending generally upwardly therefrom, the sidewall of the base including base sealing means for cooperating with a lid to form a seal; an injection-molded lid provided with resettable freshness indicator means at least in part integrally formed with the lid; a resealable vent integrally formed with the lid; and lid sealing means for cooperating with the base sealing means to form an annular interference-fit seal when the lid and base are joined to form a closed container. Preferably the base is an injection-molded base formed from

a polypropylene resin such as isotactic polypropylene. In other cases, the polypropylene resin composition comprises a propylene/ethylene copolymer.

[0013] A preferred resettable freshness indicator means comprises a plurality of bistable, eversible domed regions integrally formed on the lid. The domed regions are generally thinner at their junctions with adjacent portions of the lid than the adjacent portions of the lid; typically less than about 50% of the thickness of adjacent areas of the lid and have a generally planar central portion. Preferably, the bistable, eversible domed portions are generally thinner than adjacent portions of the lid over their profiles and have a thickness which is 50% or less than the thickness of the adjacent portions of the lid over their entire profiles.

[0014] The resealable vent preferably comprises a hinged vent panel integrally formed in the lid preferably secured to the lid at the lid's periphery which is adapted to cooperate with a vent conduit integrally formed in the lid and extending therethrough wherein the vent panel includes a sealing element integrally formed therewith adapted to seal the conduit. The sealing element includes terminal projections configured to provide audible feedback such as a snap or click indicating the container is sealed upon sealing or unsealing the vent. Most preferably, the closure element is a segmented closure element. The vent conduit and closure elements have sealing shoulders configured to engage each other to form a seal in a preferred construction.

[0015] A preferred embodiment is a microwaveable food storage container provided with a unitary base having a generally planar bottom portion and a sidewall extending generally upwardly therefrom, the sidewall defining an upper sidewall portion including an inwardly projecting annular sealing protuberance. The base further includes a rim at the upper and outer edge of the uppermost sidewall portion preferably in the shape of an inverted U. A lid which is adapted to join with the base to form a sealed enclosure is a unitary lid having a generally planar upper surface as well as:

[0016] a downwardly extending sealing band adapted to cooperate with the inwardly projecting annular sealing protuberance of the upper sidewall of the base to form an annular interference-fit seal; and

[0017] a lid rim extending outwardly with respect to the sealing band, the lid rim having a downwardly projecting outer wall provided with an undercut on its lower edge extending around the lid, the undercut being adapted to cooperate with the outer edge of the base rim to optionally provide a leakage barrier as well as audibly indicate secure closure of the container.

[0018] Preferably, the inwardly projecting sealing protuberance of the upper sidewall of the base is at least about 1.25 times the thickness of the adjacent sidewall portions of the base. Most preferably, the annular interference-fit seal formed between the sealing band and the sealing protuberance of the upper sidewall of the base is a continuous annular seal.

[0019] In typical embodiments, the downwardly projecting wall of the lid rim and the sealing band of the lid generally define an inverted U-shaped profile and the lid further comprises a downwardly extending intermediate

spacer projection between the sealing band and the downwardly projecting outer wall of the lid. Preferably, the downwardly extending intermediate projection of the lid is configured to adjust the clearance of a downwardly projecting outer leg of the lid rim and a locking bead on the outer leg of the base rim is between about 0 and about 5% when the lid and base are joined together. This may be accomplished by sizing the downwardly extending intermediate projection of the lid such that the height of the projection is from about 100% to about 105% of the clearance between the lid rim and base rim at the location of the downwardly extending intermediate projection when the lid and base are joined together.

[0020] In some embodiments, the inverted U-shape of the lid rim is sized to compress the inverted U-shape of the base rim to form a second interference-fit seal around at least a portion of the container when the lid and base are joined together. In particularly preferred embodiments, the sidewall of the base defines a sealing notch disposed on an interior side of the sidewall having an inwardly projecting annular sealing protuberance at the outward side of the notch and an inner notch wall at the inward side of the notch. The annular sealing protuberance and the inner notch wall may both include a substantially vertical portion. The inner wall most preferably has an upper chamfered portion which extends outwardly and downwardly with respect to the center of the container. Both the sealing protuberance and the inner notch wall are thicker than immediately adjacent portions of the base sidewall.

[0021] In particularly preferred embodiments, the sealing band of the lid and the notch in the upper sidewall of the base are configured such that the sealing band is wedged into the notch when the base and lid are joined together to form a sealed container.

[0022] Preferably the polymeric composition from which the inventive containers are made is a resilient composition based on polypropylene. While any suitable polypropylene polymer may be used, the polypropylene polymers are perhaps most preferably selected from the group consisting of isotactic polypropylene, and copolymers of propylene and ethylene, for example, wherein the ethylene moiety is less than about 10% of the units making up the polymer, and mixtures thereof. Suitable polymers are isotactic polypropylenes with melt-flow indices of from about 20 to about 100, usually between about 30 and 60. In some preferred embodiments, the resin from which the containers are made includes polypropylene melt blended with a polyethylene component. The polyethylene component may be any suitable polyethylene such as HDPE, LDPE, MDPE, LLDPE or mixtures thereof.

[0023] The various polyethylene polymers referred to herein are described at length in the Encyclopedia of Polymer Science & Engineering (2d Ed.), Vol. 6; pp: 383-522, Wiley 1986; the disclosure of which is incorporated herein by reference. HDPE refers to high density polyethylene which is substantially linear and has a density of generally greater than 0.94 up to about 0.97 g/cc. LDPE refers to low density polyethylene which is characterized by relatively long chain branching and a density of about 0.912 to about 0.925 g/cc. LLDPE or linear low density polyethylene is characterized by short chain branching and a density of from about 0.92 to about 0.94 g/cc. Finally, intermediate density

polyethylene (MDPE) is characterized by relatively low branching and a density of from about 0.925 to about 0.94 g/cc.

[0024] Instead of the above noted polypropylene based resinous compositions, polypropylene/polyethylene copolymers with more significant polyethylene content could be used or a polyethylene based composition could be used or polyethylene terephthalate based compositions may be used. In still further embodiments, any other suitable polymeric composition is used so long as the composition is sufficiently resilient.

[0025] As used herein the terminology polypropylene resin or polypropylene composition or like terminology refers to a composition which is predominately (more than 50 mole %) made up of propylene repeat units and includes melt blends with other resins and additives. Likewise, polyethylene resins are mostly ethylene repeat units while polyethylene terephthalate resins are mostly ethylene terephthalate repeat units. An ethylene/propylene copolymer contains both ethylene and propylene repeat units in the resin and may be made up primarily of repeat units of either species.

[0026] The terminology "interference-fit seal" refers to a seal between sealing members which are configured such that they are urged into engagement by their geometries. One sealing member thus has a larger dimension or dimensions in the free state than the dimension or dimensions of the cooperating part with which it forms a seal. When the interference-fit seal is formed, the sealing members become the same size and develop a seal through elastic compression, plastic movement of material, or both, much like interference-fit class 5 threads. See *Machinery's Handbook*, R. Green, Ed., 24<sup>th</sup> edition, Industrial Press.

[0027] The foregoing features and advantages of the present invention will be further appreciated from the drawings and description which follows.

#### BRIEF DESCRIPTION OF DRAWINGS

[0028] The invention is described in detail below with reference to the various drawings wherein like numbers designate similar parts and wherein:

[0029] FIG. 1 is an exploded view in perspective of a microwaveable food storage container provided in accordance with the present invention;

[0030] FIG. 2 an enlarged schematic view showing partial profiles of the inventive lid and container base prior to joining the lid to the base;

[0031] FIG. 2A is a further enlarged schematic view showing the annular sealing notch profile of the base;

[0032] FIG. 3 is an enlarged schematic view showing the lid of the invention attached to the base wherein the sealing band engages the sealing notch of the container, the outer sealing bead of the lid grips the lower edge of the container base rim and the intermediate spacer projection engages the arcuate rim of the container base;

[0033] FIG. 3A is a further enlarged schematic view showing the annular sealing band wedged into the sealing notch when the lid and base are joined to form a closed container;

[0034] FIG. 4 is an enlarged schematic view showing the resealable vent of the inventive container in an open position; and

[0035] FIG. 5 is an enlarged view in cross section of an eversible indicator dome of the present invention.

#### DETAILED DESCRIPTION

[0036] The invention is described in detail below with reference to the various Figures. Such discussion and illustration is for purposes of exposition only and is not intended to limit in any way the scope of the present invention which is set forth in the appended claims.

[0037] Referring generally to FIGS. 1 through 5 there is shown an embodiment of the inventive microwaveable food storage container 10 which includes a lid 12 and a base 14. Base 14 has a generally planar bottom portion 16 as well as a sidewall 18 which extends upwardly and outwardly to an upper sidewall portion. Upper sidewall portion 20 defines a notch 25 between an inner annular notch wall 27 and an annular sealing protuberance 23 at the outer side of the notch. Inner notch wall 27 preferably defines a chamfered surface 22 as well as a substantially vertical surface 27a. Annular sealing protuberance 23 has a sealing corner 29 and a substantially vertical surface 23a.

[0038] Preferably, both the sealing protuberance 23 and the inner notch wall 27 are thicker than the immediately adjacent portions of the sidewall of the base. In the embodiment illustrated, the sidewall of the container generally has a thickness A, whereas protuberance 23 has a thickness B and inner notch sidewall 27 has a thickness C. B and C may be 1.25 times or more the thickness A in order to fortify the sealing notch. For example, B and C could be 1.5 times A or twice A in some embodiments. This fortified construction is readily achieved by injection molding the base and is appreciated by reference to FIG. 2A in particular, which is a further enlarged schematic view of the interior sealing region of the container.

[0039] Upper sidewall portion 20 of the base continues upwardly and outwardly with respect to notch 25 and defines a rim 24 which terminates at a lower peripheral edge 26.

[0040] Lid 12 includes a generally planar central portion 28 as well as a curved rim 30 shaped like one leg of an inverted U. The lid also includes a downwardly extending sealing band 32 as well as an intermediate spacer projection 34 and an undercut or bead 36 to provide audible and tactile feedback that the lid is securely snapped in place on a downwardly extending portion of the rim of the base such as edge 26. Bead 36 is located on the lower edge of rim 30 and preferably forms a leakage barrier with edge 26 when snapped in place as is seen in FIG. 3, wherein there is represented an annular leakage barrier at 7.

[0041] The lid and base fit together to form an interference-fit seal as is shown schematically in FIGS. 3 and 3A in particular. Band 32 is generally disposed in notch 25 when lid 12 and base 14 are joined as shown in FIGS. 3 and 3A. Sealing band 32 has a slight inward draft and is configured to bear upon inwardly projecting, annular sealing protuberance 23 at corner 29 to form an interference-fit seal therewith. Preferably, that seal is substantially liquid proof and extends around the entire periphery of the container, as is

indicated at **3** on **FIG. 3A**; that is, seal **3** is preferably a continuous annular interference-fit seal.

[0042] The various features are sized as shown and are further understood by reference to **FIG. 2**. The height of the bottom of projection **34** above the bottom of sealing band **32** is shown as  $H_{LB}$ , while the height of the bottom of projection above bead **36** is denoted  $H_{LR}$ . The height of the base rim,  $H_{BR}$ , is from about 0.95 to about 1.0 times the height,  $H_{LR}$ , such that the clearance of the outer leg of the lid rim with the locking bead **36** is from about 0 to about 5% when the lid and base are joined together. Sealing band **32** is sized and notch **25** is positioned such that the height of the base rim above the top of notch **25**,  $H_{RN}$ , is less than  $H_{LB}$ .  $H_{LB}$ , in turn, is typically less than the height of the top of the base rim above the bottom notch **25**,  $H_{RB}$ . In summary, the lid and base features are suitably sized such that:

$$[0043] \quad H_{BR} \approx (0.95-1.0)H_{LR}$$

[0044] and

$$[0045] \quad H_{RN} < H_{LB} \leq H_{RB}$$

[0046] Preferably both the lid and base are injection molded from a polyolefin such as polyethylene or polypropylene, copolymers or melt blends thereof.

[0047] In some embodiments, rim **24** may have a span **24a** which is larger than the interior span of the inverted U-shaped rim **30** of the lid such that the rim of the base is compressed in the direction of arrow **33** when the lid and base are joined. In such cases, a second annular interference-fit seal **9** is formed between rim surfaces.

[0048] Most preferably, sealing band **32** and notch **25** are configured so that annular band **32** is wedged into annular notch **25** as is seen in **FIG. 3A**, preferably between surfaces **23a** and **27a**. In such cases, the profile of band **32** undergoes a direction change with respect to its line of contact with corner **29** of protuberance **23**. That direction change may be inward or outward with respect to the upper profile of the sealing band, but is most preferably inward as shown in **FIG. 3A**, wherein an additional annular leakage barrier is formed at **11**.

[0049] The containers of the invention are particularly suitable for storing food and later microwaving the food in a microwaveable oven. During this process, steam may be generated as the food is heated to an elevated temperature. To accommodate the vapor, the inventive containers are provided with a resealable steam vent in a preferred embodiment. The resealable vent may take any suitable configuration. One preferred embodiment is shown schematically in **FIG. 4**. The resealable vent shown in **FIG. 4** is integrally formed with the rest of the lid **12** and includes a circular conduit **40** extending through the base as well as a hinged vent panel **42** attached to the remainder of the lid by an integral hinge **44**. Vent panel **42** includes a segmented cylindrical closure element **46** having a sealing shoulder **45** which is adapted to seal vent conduit **40** at shoulder or ledge **47**. To close the vent hinged panel **42** is swung in the direction of arrow **48** such that its edge **50** aligns generally with a recess **52** formed in the top of the lid. Most preferably, the closure element is further provided with a plurality of terminal outward radially extending projections **49** which snap into place when pressed through conduit **40**. These projections are sized to securely seal the vent and provide

audible and tactile feedback upon sealing or unsealing the vent. The recess is provided so that when the vent panel is closed a user may readily insert a finger to swing the panel to the open position as is shown in **FIG. 4**.

[0050] In preferred embodiments, the containers of the invention are preferably provided with freshness indicators. Such indicators may be eversible domed portions integrally formed in the lid as is shown in **FIGS. 1 and 5**. Generally the eversible domed portions are bistable in the sense that they can be pressed either inwardly to a stable position or outwardly to a stable position. In the embodiment shown in **FIG. 1** there are provided seven domed portions such as shown at **54** each of which is adjacent indicia indicating a day of the week. In this way a user can mark or record the day that a given entree or other food was stored. The eversible dome portions are generally thinner than adjacent portions of the lid and have a planar central portion as will be appreciated particularly from **FIG. 5**.

[0051] There is shown in **FIG. 5** a cross section of an eversible domed portion integrally formed in lid **12**, the domed portion **54** includes a generally planar central portion **56** as well as a downwardly extending sidewall **58** as shown in the diagram. It is noted that the adjacent portion of lid **12** has a thickness **60** which is more than twice the thickness of the eversible dome portion of the microwaveable container. Typically the domed portion is less than 50% of the thickness of the adjacent areas of the lid as is shown in **FIG. 5**. This thinning may extend over the entire domed portion of the containers or may be localized at the boundaries between the domed portion and the remainder of the lid indicated generally at **62**. That is to say, it is important that at least the parts of the domed eversible indicators that are next to the adjacent lid portions are thinner than the adjacent lid portion so that the eversible domes may be readily inverted to indicate a date or other pertinent information.

[0052] Additional features of the inventive containers may include, for example, arcuate tabs **64**, **66**, **68** which are configured to have an appearance similar to vent panel **42** in the closed position. The tabs project outwardly from the corners in order to facilitate opening and closing of the container. Arcuate tabs **64**, **66** and **68** project outwardly and facilitate removal of lid **12** from base **14** by providing a levering action when pressed upwardly urging bead **36** out of engagement with edge **26** of base **14**.

[0053] While the invention has been described in connection with several examples, modifications to those examples within the spirit and scope of the invention will be readily apparent to those of skill in the art. In view of the foregoing discussion, relevant knowledge in the art and references including co-pending applications discussed above in connection with the Background and Detailed Description, the disclosures of which are all incorporated herein by reference, further description is deemed unnecessary.

What is claimed is:

1. A microwaveable food storage container comprising:
  - (a) a unitary base having a generally planar bottom portion and a sidewall extending generally upwardly therefrom, the sidewall of the base including base sealing means for cooperating with a lid to form a seal;

- (b) an injection-molded lid provided with:
- (i) resettable freshness indicator means at least in part integrally formed with the lid;
  - (ii) a resealable vent integrally formed in the lid; and
  - (iii) lid sealing means for cooperating with the base sealing means to form an annular interference-fit seal when the lid and base are joined to form a closed container.
2. The microwaveable food storage container according to claim 1, wherein the base is an injection-molded base.
3. The microwaveable food storage container according to claim 2, wherein the lid and base are formed from a polypropylene resin.
4. The microwaveable food storage container according to claim 3, wherein the polypropylene resin composition comprises isotactic polypropylene.
5. The microwaveable food storage container according to claim 3, wherein the polypropylene resin composition comprises a propylene/ethylene copolymer.
6. The microwaveable food storage container according to claim 1, wherein the resettable freshness indicator means comprises a plurality of bistable, eversible domed regions integrally formed on the lid.
7. The microwaveable food storage container according to claim 6, wherein the domed portions are generally thinner at their junctions with adjacent portions of the lid than the adjacent portions of the lid.
8. The microwaveable food storage container according to claim 7 wherein the bistable, eversible domed portions of the lid have a peripheral portion which is less than about 50% of the thickness of adjacent areas of the lid.
9. The microwaveable food storage container according to claim 8, wherein the bistable, eversible domed portions have a generally planar central portion.
10. The microwaveable food storage container according to claim 6, wherein the bistable, eversible domed portions are generally thinner than adjacent portions of the lid over their profiles.
11. The microwaveable food storage container according to claim 10, wherein the bistable, eversible domed portions of the lid have a thickness which is 50% or less than the thickness of the adjacent portions of the lid.
12. The microwaveable food storage container according to claim 11, wherein the bistable, eversible domed portions of the lid have a generally planar central portion.
13. The microwaveable food storage container according to claim 1, wherein the resealable vent comprises a hinged vent panel integrally formed in the lid and secured to the lid at the lid's periphery.
14. The microwaveable food storage container according to claim 13, wherein the resealable vent comprises a vent conduit integrally formed in the lid and extending therethrough and the vent panel includes a sealing element integrally formed therewith adapted to seal the conduit.
15. The microwaveable food storage container according to claim 14, wherein the sealing element includes terminal projections configured to provide an audible indication sealing or unsealing the vent.
16. The microwaveable food storage container according to claim 15, wherein the sealing element is a segmented closure element.
17. The microwaveable food storage container according to claim 14, wherein the vent conduit and closure elements have sealing shoulders configured to engage each other to form a seal.
18. The microwaveable food storage container according to claim 1, comprising:
- (a) a unitary base having a generally planar bottom and a sidewall extending generally upwardly therefrom,
    - (i) the sidewall defining an upper sidewall portion including an inwardly projecting annular sealing protuberance;
    - (ii) the base further including a rim extending outwardly from the upper sidewall portion of the base; and
  - (b) a unitary lid having a generally planar upper surface as well as:
    - (i) a downwardly extending sealing band adapted to cooperate with the inwardly projecting annular sealing protuberance of the upper sidewall of the base to form an annular interference-fit seal; and
    - (ii) a lid rim extending outwardly with respect to the sealing band, the lid rim having a downwardly projecting outer wall provided with an undercut on its lower edge extending around the lid, the undercut being adapted to cooperate with the outer edge of the base rim to audibly indicate secure closure of the container.
19. The microwaveable food storage container according to claim 18, wherein the sealing protuberance of the uppermost sidewall portion of the base is at least about 1.25 times the thickness of the adjacent sidewall portions of the base.
20. The microwaveable food storage container according to claim 18, wherein the annular interference-fit seal formed between the sealing band and the sealing protuberance of the upper sidewall of the base is a continuous annular seal.
21. The microwaveable food storage container according to claim 18, wherein the downwardly projecting wall of the lid rim and the sealing band of the lid generally define an inverted U-shaped profile.
22. The microwaveable food storage container according to claim 21, wherein the lid further comprises a downwardly extending intermediate spacer projection between the sealing band and the downwardly projecting outer wall of the lid rim.
23. The microwaveable food storage container according to claim 22, wherein the rim of the base is an inverted U-shape.
24. The microwaveable food storage container according to claim 23, wherein the downwardly extending intermediate projection of the lid is configured to adjust the clearance of a downwardly projecting outer leg of the lid rim and a locking bead on the outer leg of the base rim to a clearance between about 0 and about 5% when the lid and base are joined together.
25. The microwaveable food storage container according to claim 23, wherein the inverted U-shape of the lid rim is sized to compress the inverted U-shape of the base rim to form a second interference-fit seal around at least a portion of the container when the lid and base are joined together.

26. The microwaveable food storage container according to claim 18, wherein the undercut on the lid rim cooperates with the outer edge of the base rim to form another leakage barrier.

27. A microwaveable storage container according to claim 1, comprising:

- (a) a unitary base having a generally planar bottom portion and a sidewall portion extending generally upwardly therefrom;
  - (i) the sidewall defining an upper sidewall portion including a sealing notch disposed on an interior side of the sidewall having an inwardly projecting annular sealing protuberance at the outward side of the notch and an inner notch wall at the inward side of the notch;
  - (ii) the base further including a rim extending outwardly from the upper sidewall of the base;
- (b) a unitary lid having a generally planar upper surface as well as:
  - (i) a downwardly extending sealing band adapted to cooperate with the inwardly projecting annular sealing protuberance of the upper sidewall of the base to form an annular interference-fit seal; and
  - (ii) a lid rim extending outwardly with respect to the sealing band, the lid rim having a downwardly projecting outer wall optionally provided with an undercut adapted to cooperate with the outer edge of the base rim to audibly indicate secure closure of the container.

28. The microwaveable food storage container according to claim 27, wherein the downwardly extending inner notch wall includes a substantially vertical portion and an upper chamfered portion which extends downwardly and outwardly.

29. The microwaveable food storage container according to claim 28, wherein the annular sealing protuberance at the outer side of the notch includes a substantially vertical portion.

30. The microwaveable food storage container according to claim 27, wherein the sealing protuberance is thicker than adjacent portions of the base sidewall immediately above the sealing protuberance.

31. The microwaveable food storage container according to claim 27, wherein the inner notch wall of the sealing notch is thicker than the sidewall of the base immediately below the inner sealing notch wall.

32. A microwaveable storage container according to claim 1, comprising:

- (a) a unitary base having a generally planar bottom portion and a sidewall portion extending generally upwardly therefrom;
  - (i) the sidewall defining an upper sidewall portion including a sealing notch disposed on an interior side of the sidewall having an inwardly projecting annular sealing protuberance at the outward side of the notch and an inner notch wall with a downwardly extending inner surface at the inward side of the notch;
  - (ii) the base further including a rim extending outwardly from the upper sidewall of the base;
- (b) a unitary lid having a generally planar upper surface as well as:
  - (i) a downwardly extending annular sealing band adapted to cooperate with the inwardly projecting annular sealing protuberance of the upper sidewall of the base to form an annular interference-fit seal; and
  - (ii) wherein the annular sealing band of the lid and the sealing notch of the base are configured so that the sealing band becomes wedged in the notch when the lid and base are joined together to form a closed container; and
  - (iii) a lid rim extending outwardly with respect to the sealing band, the lid rim having a downwardly projecting outer wall optionally provided with an undercut adapted to cooperate with the outer edge of the base rim to audibly indicate secure closure of the container.

33. The microwaveable storage container according to claim 32, wherein the downwardly projecting wall of the lid rim and the sealing band of the lid generally define an inverted U-shaped profile and the rim of the base is an inverted U-shape.

34. The microwaveable storage container according to claim 32, wherein the lower edge of the sealing band is configured to cooperate with the downwardly extending inner surface of the inner notch wall of the base to form another leakage barrier when the lid and base are joined together to form a closed container.

\* \* \* \* \*