



US 20060151348A1

(19) **United States**

(12) **Patent Application Publication**
Willard

(10) **Pub. No.: US 2006/0151348 A1**

(43) **Pub. Date: Jul. 13, 2006**

(54) **RACK-HUNG LOADABLE DEBIT CARD PACKAGE**

Publication Classification

(51) **Int. Cl.**
B65D 85/48 (2006.01)

(75) Inventor: **Rick L. Willard**, Las Vegas, NV (US)

(52) **U.S. Cl.** **206/449; 206/806**

Correspondence Address:
HALLISKY & PHILIPP
1725 WESTLAKE AVENUE NORTH, SUITE
150
SEATTLE, WA 98109 (US)

(57) **ABSTRACT**

A dual card package having cards secured within. A first panel of the package includes an access flap that is pivotal about a fold line. A second panel is also foldable along a fold line substantially corresponding to the fold line of the access flap. One card is accessible by the access flap so that the package is selectively movable from a closed position in which an magnetic strip on the card is covered and an open position in which the access flap and the second panel is swung out from the card such that the magnetic strip is exposed for activation purposes.

(73) Assignee: **WOW! TECHNOLOGIES, INC.**, Las Vegas, NV (US)

(21) Appl. No.: **10/905,572**

(22) Filed: **Jan. 11, 2005**

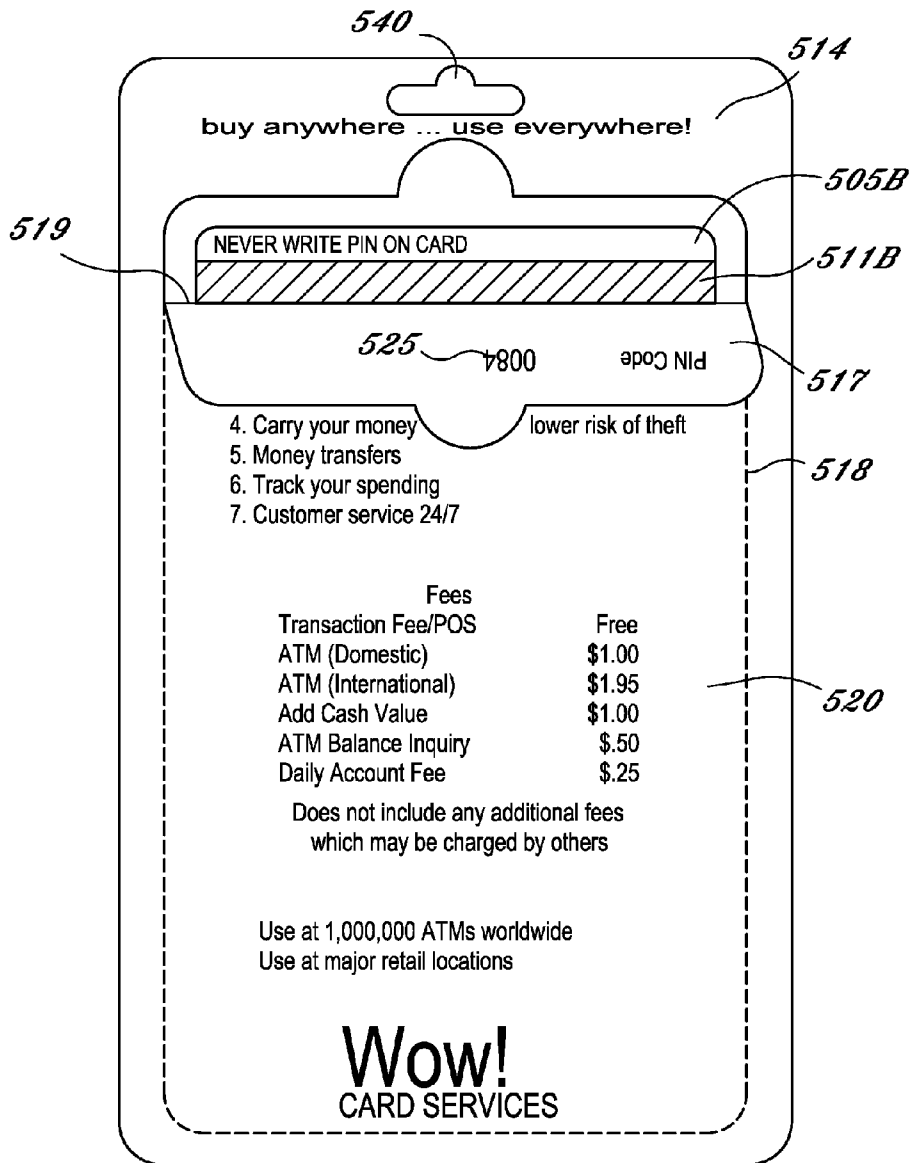

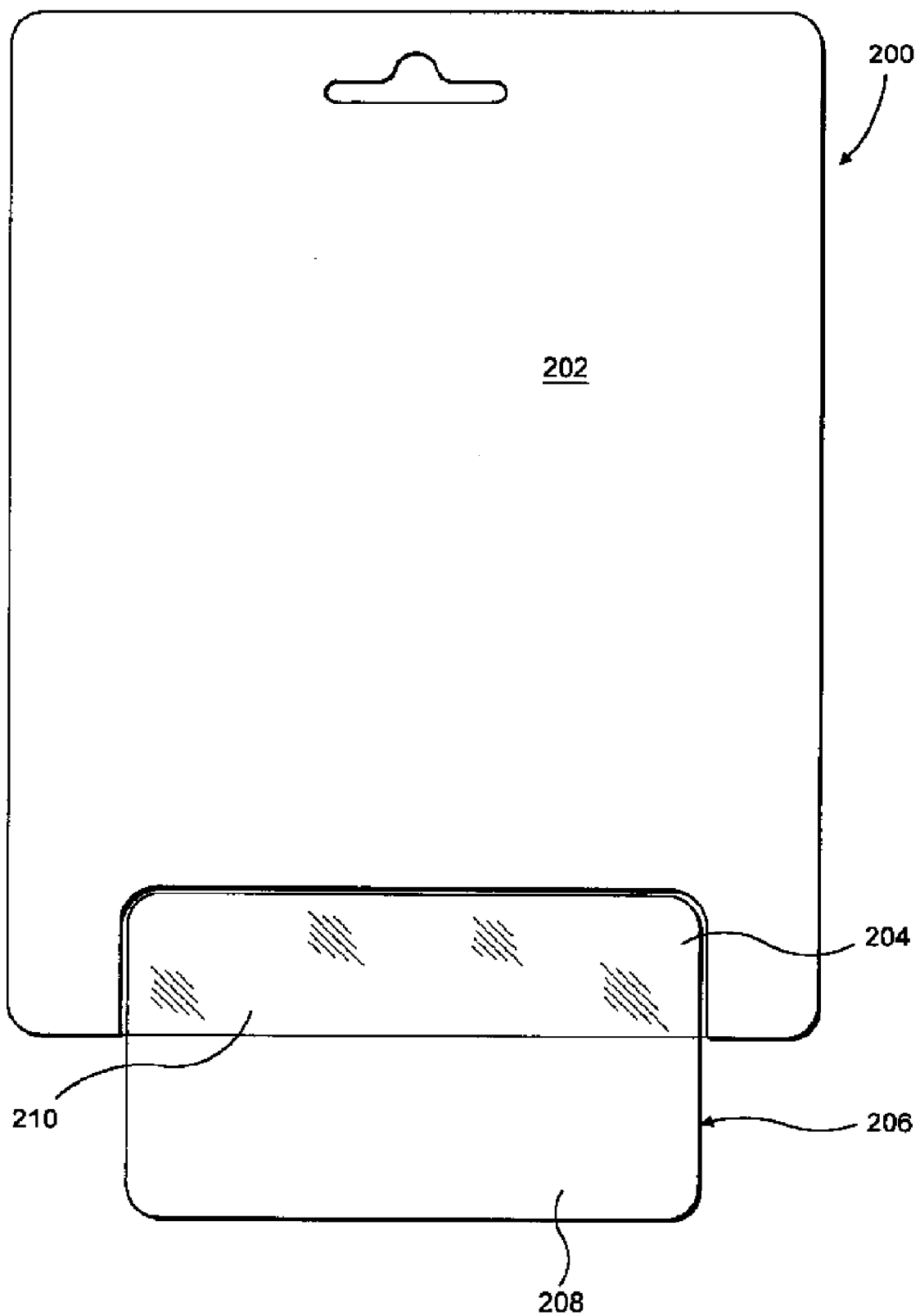

FIG. 1
PRIOR ART

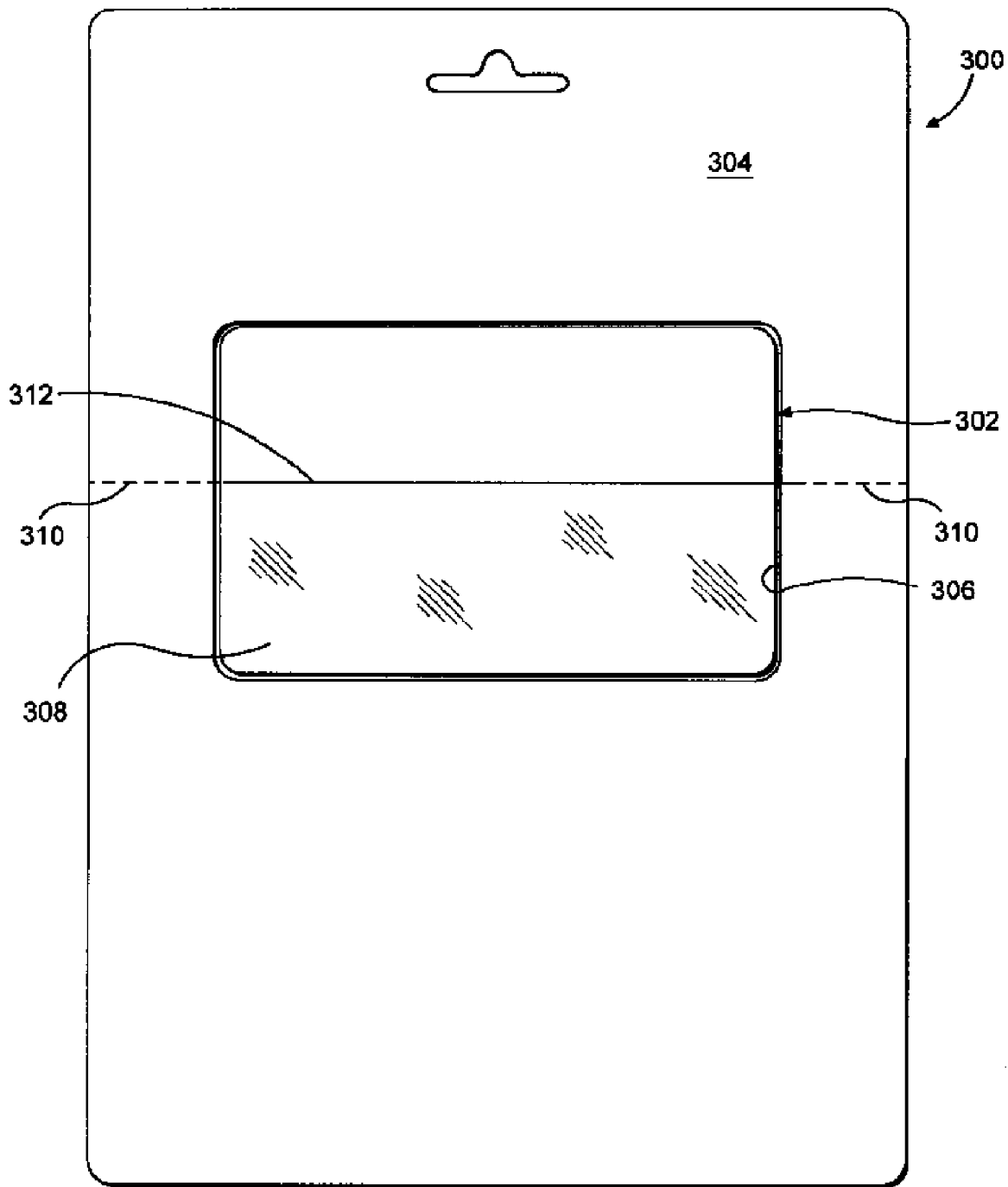

FIG. 2
PRIOR ART

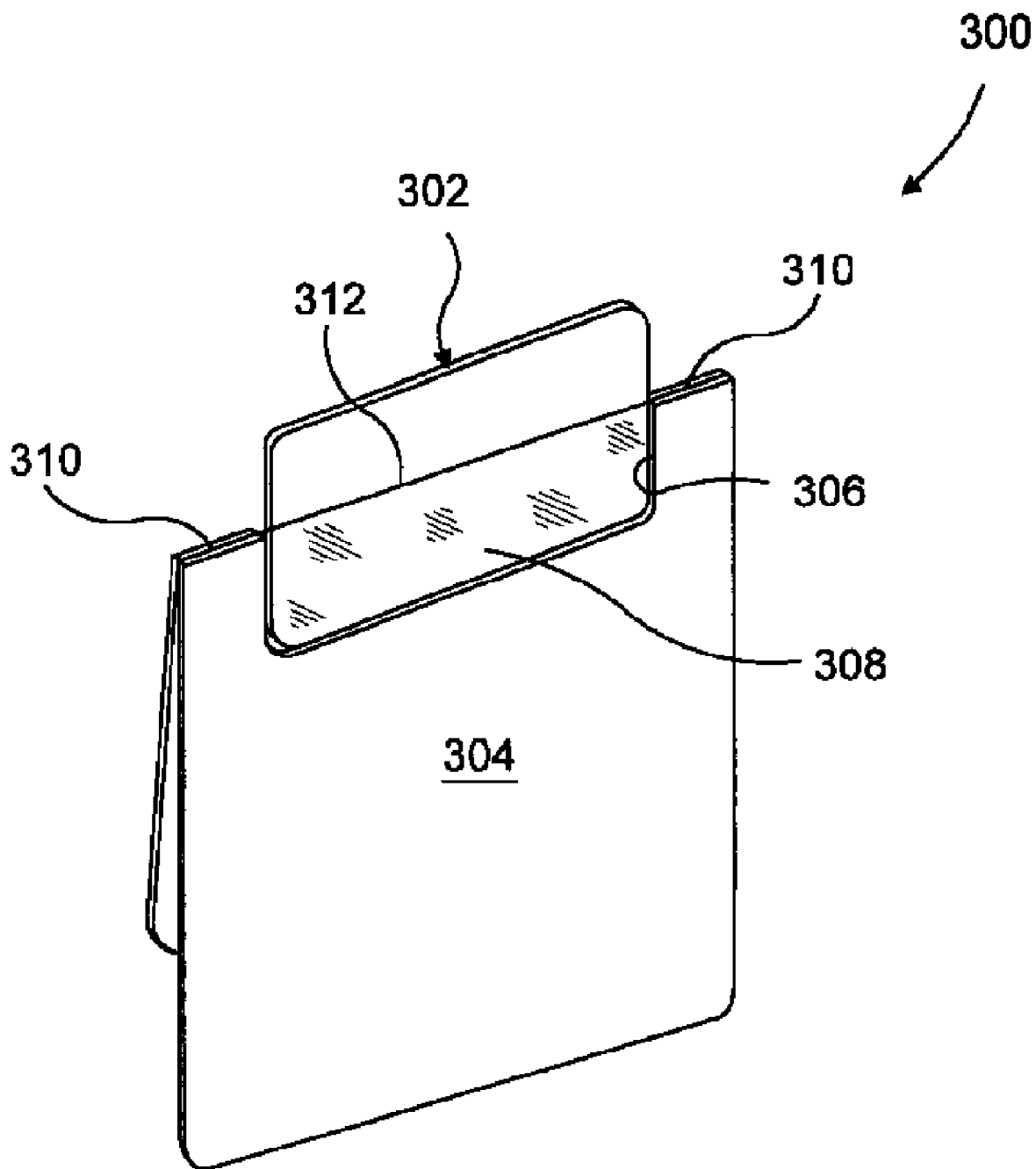
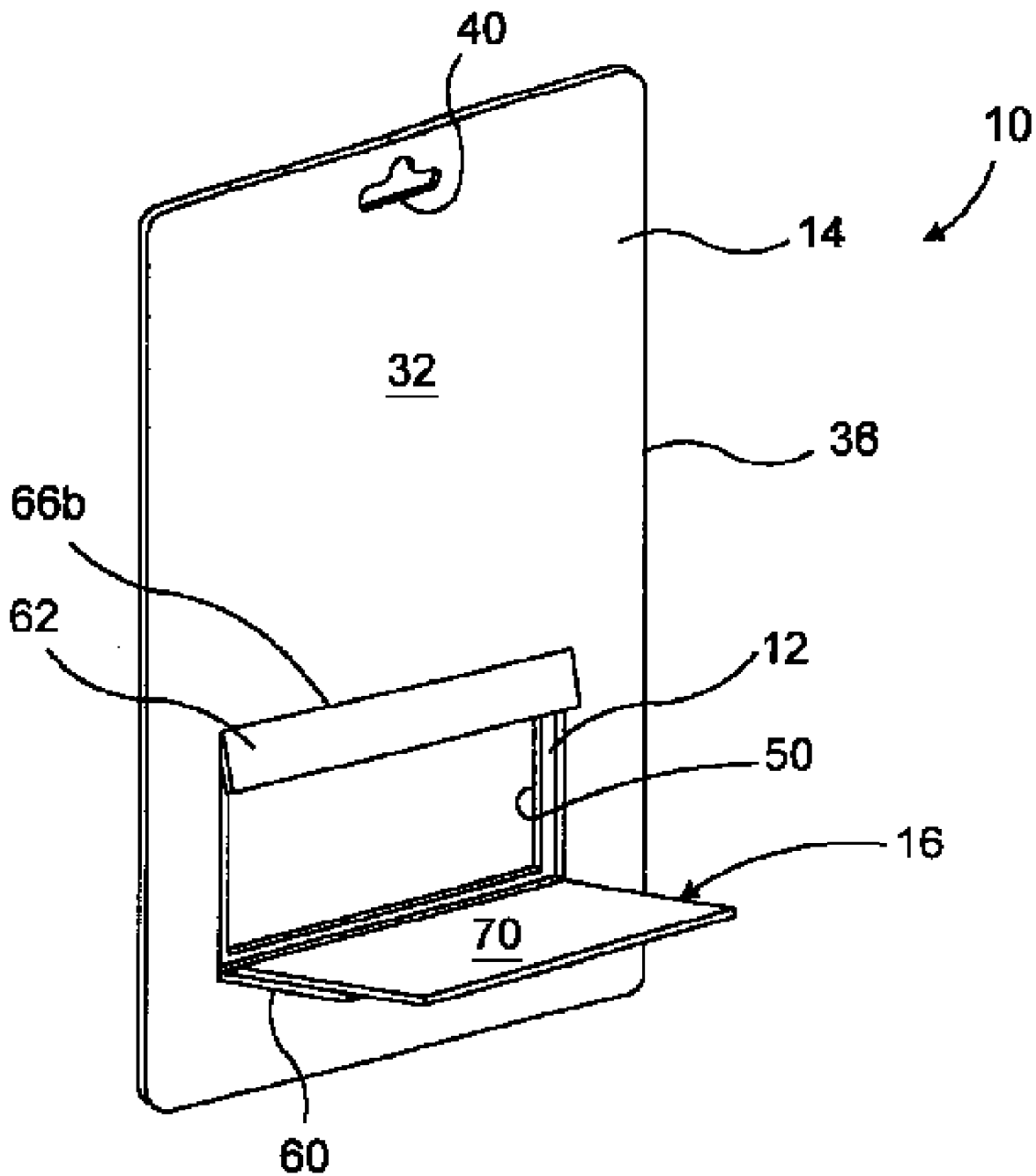

FIG. 3
PRIOR ART



**FIGURE 4
(PRIOR ART)**

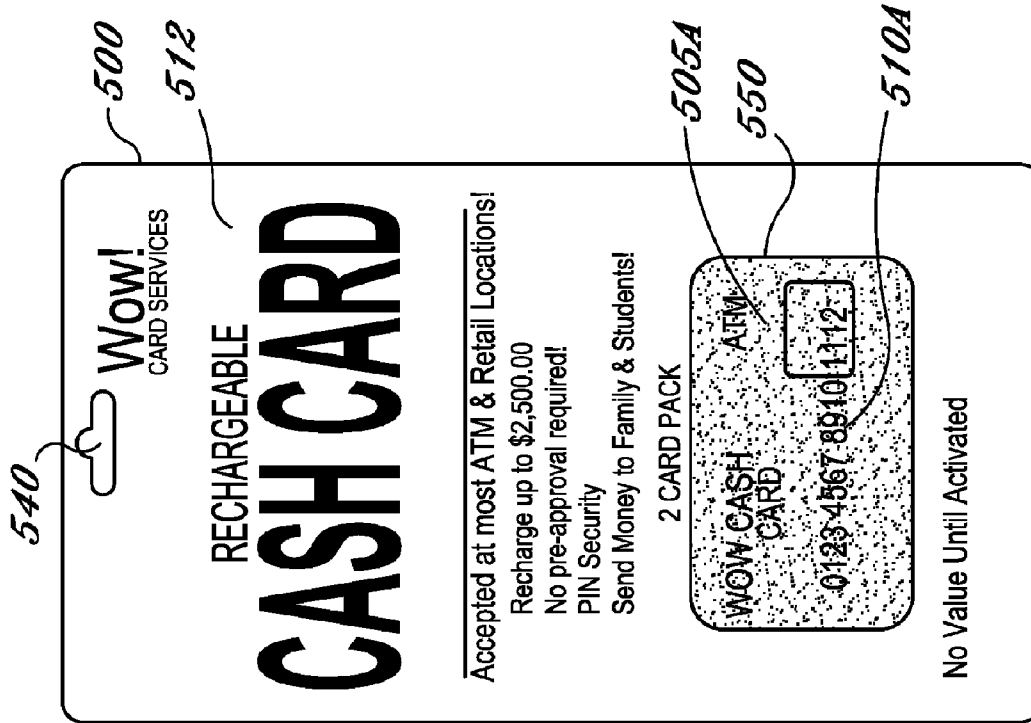

FIG. 5

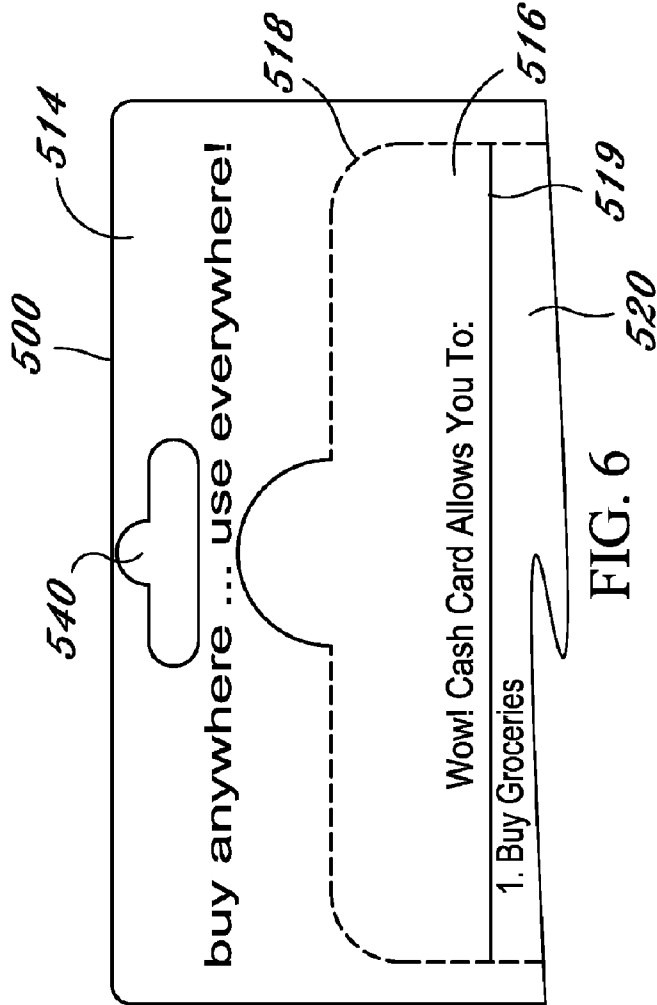

FIG. 6

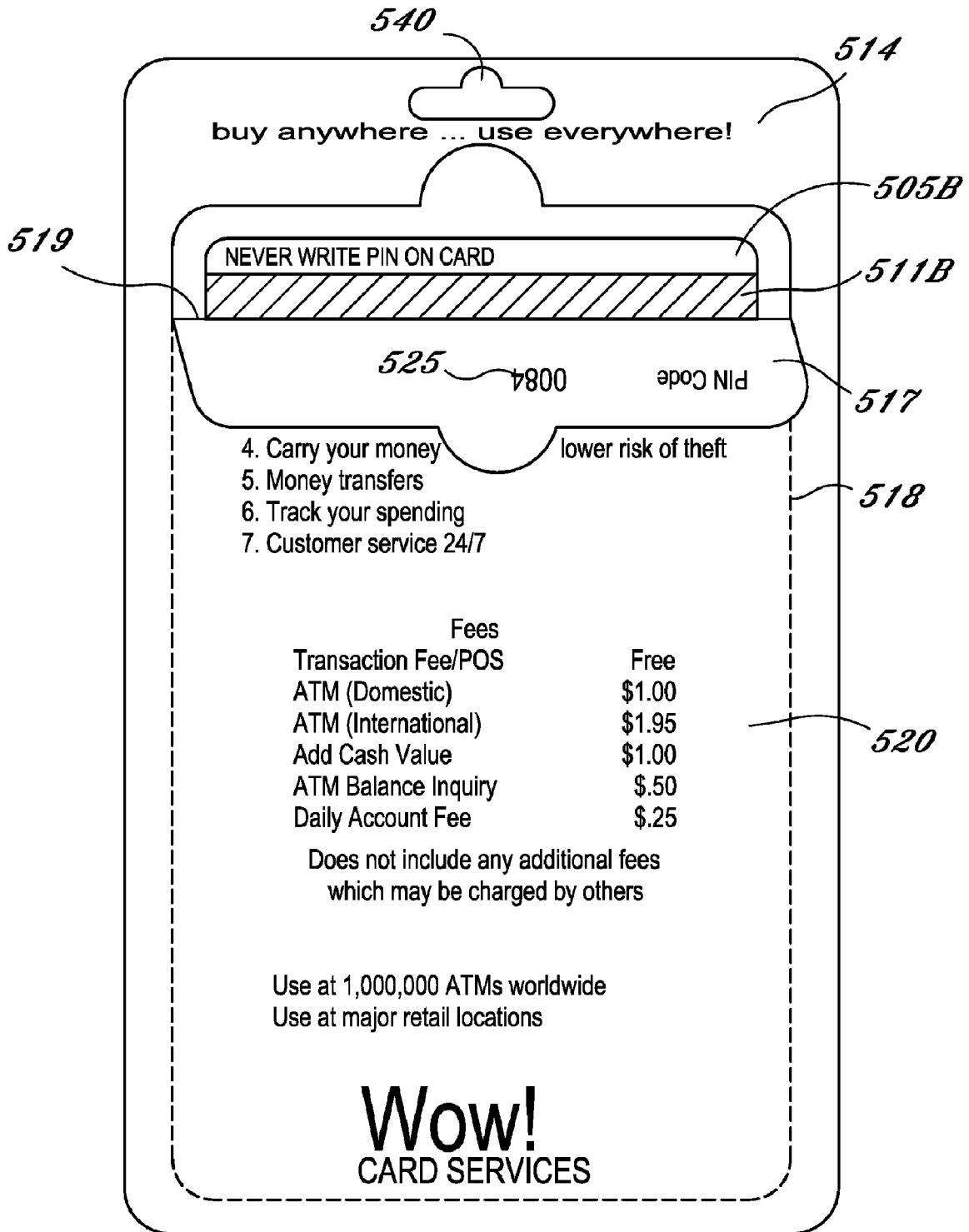

FIG. 7

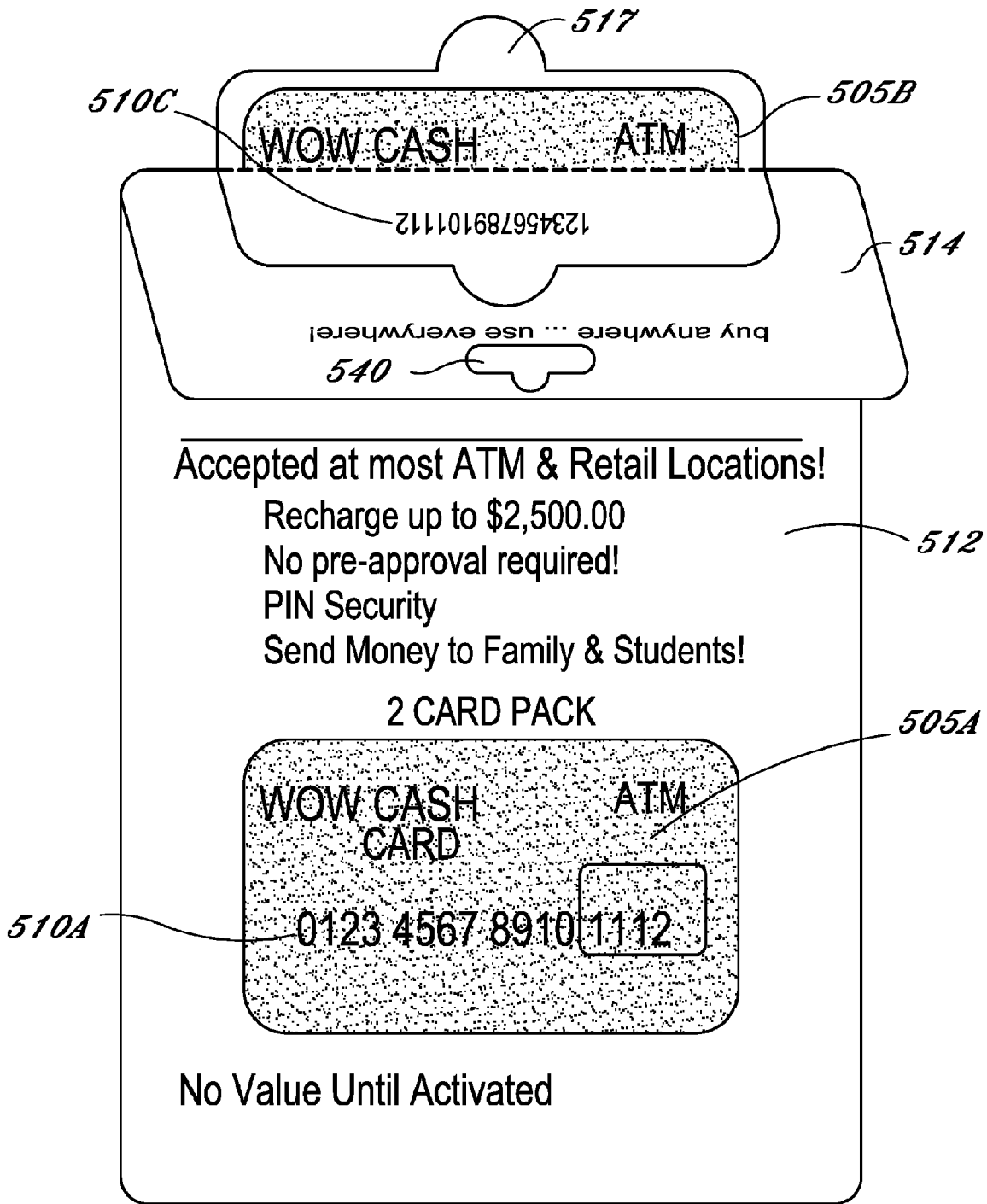
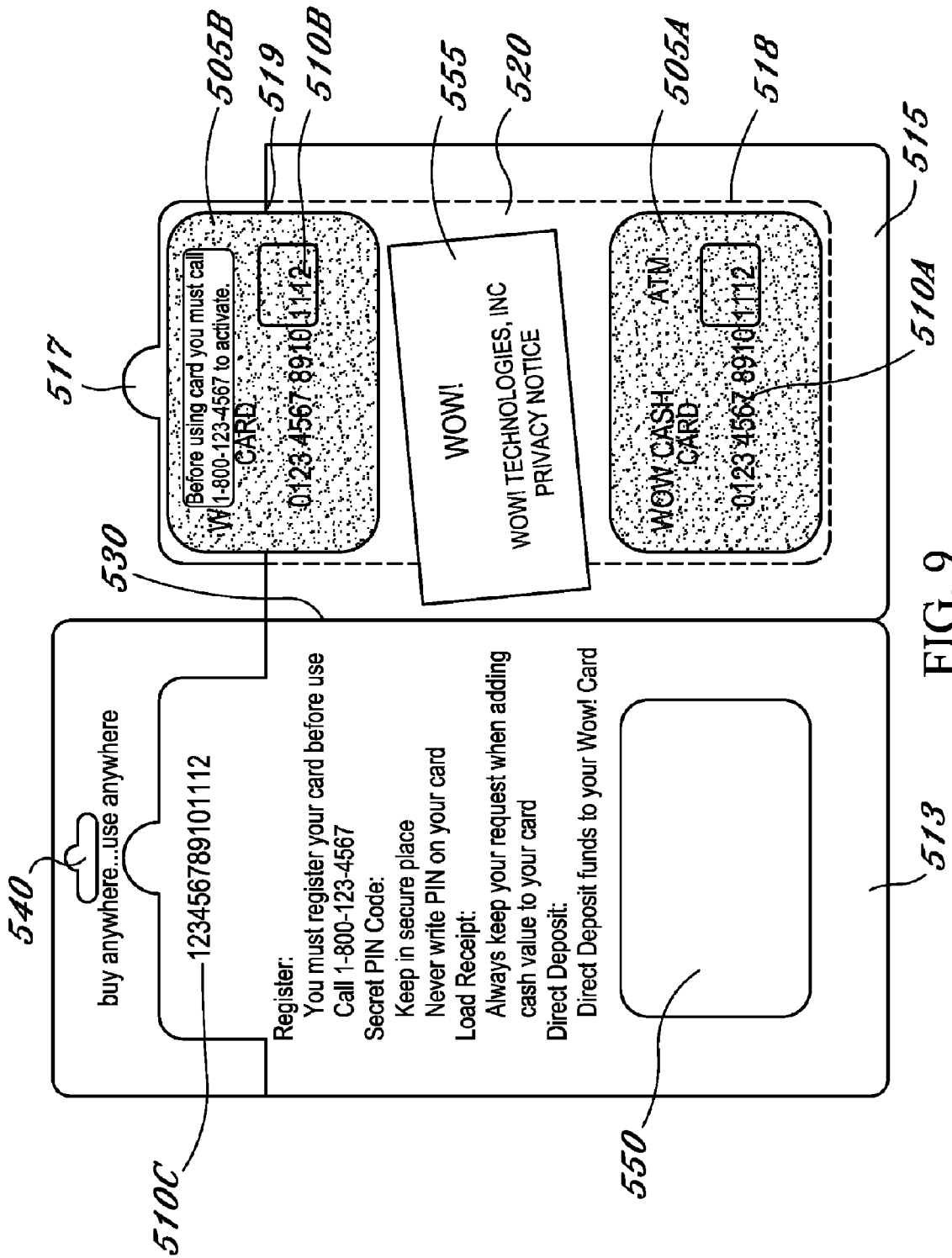

FIG. 8



RACK-HUNG LOADABLE DEBIT CARD PACKAGE

FIELD

[0001] The present invention relates to packaging and more particularly to a package for debit cards such as phone cards, bankcards, credit cards, and debit cards.

BACKGROUND

[0002] Wallet cards are well known and widely used for a variety of purposes. For example, wallet cards have long been used as credit cards, debit cards, rental cards and bankcards. Wallet cards are also used to represent a variety of pre-paid services. Prominent examples of this are pre-paid phone cards, merchant cards, gift cards and debit cards that are offered by a number of companies. To reduce the risk of theft, pre-paid cards are typically stored, or displayed, in an inactive status. As a result, pre-paid cards usually require activation before they will function. Often, activation is performed at the time of purchase by reading a unique identification number encoded on the card. This method is widely referred to as "point-of-sale activation." The identification number is generally stored on a magnetic strip, encoded into a bar code, or stored in a memory device (such as a smart chip) attached to the card. The identification number is read by a card reader (e.g. a magnetic card reader, bar code scanner, smart chip reader or the like) and then transmitted to a device that activates the card. Once activated, the card entitles the holder to access the functionality of the card.

[0003] A variety of phone card packages are commercially available that facilitate point-of-sale activation of the pre-paid card by packaging the card so that the identification number is accessible for reading without removing the card from the package. One such type of phone card package 200 includes front 202 and rear (not shown) panels that sandwich the upper portion 204 of the card 206 (See FIG. 1). The lower portion 208 of the card 206 (to which the magnetic strip is attached) protrudes from the package 200 so that it can be passed through a card reader without removing the card from the package 200. The front panel 202 includes a transparent plastic window 210 that covers the top of card 206 and permits viewing of graphics printed thereon. To prevent the card 206 from being pulled out of the package 200, the card 206 is secured to the package 200. In a particularly advantageous construction, the card 206 is secured to the panels by a layer of peelable adhesive (not shown). In other constructions, the card is secured to the panels by adhesive tape or by a portion of the window that extends through a hole in the card. The plastic window significantly increases the cost of this package. In addition, because the identification number is always accessible, it is difficult to determine if the card has been tampered with, for example, if it has previously been activated. Further, because the portion of the card carrying the identification number extends freely from the card, the identification number can be intentional or inadvertently damaged during shipping, handling and display, for example, by scratching the magnetic strip. Additionally, after the card is purchased, it is relatively difficult to remove the card from the package because the front and rear panels must be separated to gain access to the card.

[0004] A second type of point-of-sale phone card package 300 includes panels that can be folded about the card 302 to

provide access to the identification number (See FIGS. 2 and 3). The card 302 is sandwiched between front 304 and rear (not shown) panels, and includes a magnetic strip (not shown) extending across the top, rear of the card 302. The rear panel covers the rear of the card and includes a fold line (not shown) that permits it to fold backward at a point below the magnetic strip. The front panel defines a card-sized opening 306 that receives the card 302. A transparent window 308 is positioned in the opening 306 to help retain the card. Because the upper portion of the package 300 is required to fold away from the card 302, the window 308 extends through only a portion of the opening 306 and its upper extent 312 coincides with the fold line in the rear panel. The front panel 304 also includes a line of perforations 310 that coincides with the fold line in the rear panel and the upper extent 312 of the window 308. The perforations 310 permit the front panel 304 to tear apart when the package 300 is folded to provide access to the magnetic strip (See FIG. 3). This makes it easier to fold the package 300 and prevents the rear panel from buckling or creasing when folded. Although this construction protects the card prior to activation, the transparent window increases the cost of the package. Further, the presence of only a partial window may be aesthetically unpleasing to customers. In addition, because the front panel is torn apart at the line of perforations, the integrity and aesthetic appearance of the package is compromised when the card is exposed. Additionally, once the package has been folded open, the panels hang limply providing little or no protection for the card. Further, after the card is purchased, it is relatively difficult to remove the card from the package because the front and rear panels must be separated to gain access to the card.

[0005] Another prior art wallet card package is illustrated in FIG. 4. The package 10 includes front 12 and rear 14 panels that close about and secure the wallet card 16. The front panel 12 defines an opening 50 that permits viewing of the wallet card 16. As shown in FIG. 4, wallet card 16 is swung out from between the front 12 and rear 14 panels to facilitate point-of-sale activation. This permits the card 16 to be passed through a card reader without removing the card 16 from the package 10. Such a card package is suitable for a pre-paid telephone card having its identification number stored in a magnetic strip.

[0006] The prior art packages all described above, fail to provide additional activation and security features suitable for use with debit cards. In particular, there is no suitable provision in such prior art packaging for efficient access to a debit card's personal information number ("PIN"), let alone efficient access that also provides access to the debit card for activation purposes.

BRIEF DESCRIPTION OF THE DRAWINGS

[0007] FIG. 1 is a front plan view of a first wallet card package according to the prior art.

[0008] FIG. 2 is a front plan view of a second wallet card package according to the prior art.

[0009] FIG. 3 is a perspective view of the second wallet card package according to the prior art with the wallet card exposed.

[0010] FIG. 4 is a perspective view of a third wallet card package according to the prior art with the wallet card exposed.

[0011] FIG. 5 is a front plan view of the wallet card package of an embodiment.

[0012] FIG. 6 is a rear plan view of a portion of the wallet card package of an embodiment with the access flap in the closed position.

[0013] FIG. 7 is a rear plan view of the wallet card package of an embodiment with the access flap in an open position.

[0014] FIG. 8 is a front plan view of the wallet card package of an embodiment in an open position.

[0015] FIG. 9 is an interior plan view of the wallet card package of an embodiment in an open position.

DETAILED DESCRIPTION

[0016] In the following description, reference is made to the accompanying drawings that form a part hereof wherein like numerals designate like parts throughout, and in which are shown, by way of illustration, specific embodiments in which the invention may be practiced. It is to be understood that other embodiments may be utilized and structural or logical changes may be made without departing from the scope of the present invention. Therefore, the following detailed description is not to be taken in a limiting sense, and the scope of the present invention is defined by the appended claims and their equivalents.

[0017] Embodiments of the present invention include a user-friendly packaging for loadable debit cards.

[0018] In the following description, various aspects of selected embodiments of the present invention will be described. However, it will be apparent to those of ordinary skill in the art and others that alternate embodiments may be practiced with only some or all of the aspects of the present invention. For purposes of explanation, specific numbers, materials and configurations are set forth in order to provide a thorough understanding of the present invention. However, it will be apparent to those of ordinary skill in the art and others that alternate embodiments may be practiced without the specific details. In other instances, well-known features are omitted or simplified in order not to obscure the illustrated embodiments.

[0019] The various operations will be described as multiple discreet steps in turn, in a manner that is most helpful to understanding of the present invention. However, the order of description should not be construed to imply that these operations are necessarily order dependent. In particular, these operations may not be performed in the order of presentation.

[0020] The phrase "in one embodiment" is used repeatedly. The phrase generally does not refer to the same embodiment, however, it may. The terms "comprising," "having" and "including" are synonymous, unless the context dictates otherwise.

[0021] Embodiments shown in FIGS. 5-9 and described below, illustrate an exemplary dual debit card package. While the package may advantageously be used with multiple debit cards to provide a single activation (and loading) of the jointly packaged debit cards; in other embodiments only a single debit card is packaged, activated and loaded.

[0022] A debit card package, according to one embodiment, is illustrated in FIG. 5 and generally designated 500. The package 500 includes front 512 and rear 514 (see FIG. 6) panels that close about and secure the debit card 516. The front panel 512 defines an opening 550 that permits viewing of the wallet card 505A. As shown in FIG. 7, access flap 516 (see FIG. 6) can be swung out from between the rear 514 panels to facilitate point-of-sale activation. This permits a card 505A-B to be passed through a card reader without removing the card 505A-B from the package 500. For purposes of disclosure, and not by way of limitation, exemplary embodiments are described in connection with a loadable debit card having activation data stored in a magnetic strip. Various embodiments are suited for use with other types of wallet cards, such as bankcards, credit cards, non-loadable debit cards, rental cards, gift cards, information cards, telephone cards and other similar cards, and with other mechanisms for representing the activation information, such as bar codes or smart chips.

[0023] The front panel 512 may be a generally rectangular, planar sheet of paperboard. The front panel 512 defines a card opening 550 that permits viewing a card 505A. The opening 550 may be similar in shape to, but slightly smaller than, the periphery of the card 505A. As a result, the front panel 512 overlaps the card 505A around its entire periphery. This prevents the card 505A from being pulled forwardly through the opening 550 without damaging the package 500.

[0024] In FIG. 6, the rear panel 514 is similar to the front panel 512, and may be a generally rectangular, planar sheet of paperboard (See FIG. 7). The rear panel 514 includes an access flap 516 and an access panel 520, both of which are defined by a plurality of cut lines 518. The cut lines are leave a plurality of bridges across of the cut lines 518 such that the access flap 516 and an access panel 520 are held in the closed position until appropriate force is applied to the cut lines 518. The size, location and number of bridges can be varied from application to application to provide the desired resistance to opening. In some applications, the bridges can be eliminated and other forms of resistance to folding can be relied upon to retain the access flap 516 and access panel 520 in the closed position until forcibly opened. Alternatively, the partial cut lines 518 can be replaced by perforations or partial cut lines (i.e. cut lines in which the cut does not extend entirely through the panel) or the like.

[0025] As shown in FIGS. 6-7, the access flap 516 is intended to fold or swing out from the rear panel 514. Score lines or fold lines 519 may be formed in the rear panel 514 to facilitate folding of the access flap 516 along the desired line. The respective sizes of the access flap 516 and an access panel 520 will vary from application to application. The access flap 516 is preferably sized and configured so that it does not interfere with passage of the card 505B through a conventional card reader. For example, the folded edge of the access flap 516 preferably terminates a sufficient distance from the magnetic strip 511B so that it is not required to pass through the card slot on the card reader (not shown). In debit card or other PIN-based card applications, the access flap 516 may include copy of the cards' 505A-B PIN 525 on a rear access flap surface 517, permitting viewing of the PIN 525.

[0026] The debit cards 505A-B are generally conventional, and may be manufactured from a sheet of plastic

material. The cards **505A-B** include card numbers **510A-B** and magnetic strip **511B** (magnetic strip of card **505A** not shown). The magnetic strip **511B** is applied to a surface of the card **505B**, such that the magnetic strip **511B** may be passed through a card reader when the access flap **516** is open (as described below). The dimensions of the cards **505A-B** may vary from application to application as desired. In addition, if desired, the magnetic strip **511B** can be replaced by a bar code or other form of machine-readable identification and/or activation information.

[0027] The debit cards **505A-B** are manufactured using conventional techniques and apparatus. The one surface card **505A**, which is visible through the opening **550** in the front panel **512**, may be printed with the desired graphics.

[0028] The debit cards **505A-B** are secured to the package **500** by a layer of peelable adhesive (not shown). The adhesive may be either a hot melt or a cold glue. A suitable hot melt is available from L&D Adhesives of Comstock Park, Mich. under the trade name INSTANT-LOK. Suitable cold glues include formulated rubber latex available from L&D Adhesives under the trade name National 35-6148 and compounded natural rubber latex available from P-H-X, Inc. Of Milwaukee, Wis. under the trade name PHX 4011. The peelable adhesive is characterized by its relatively high shear strength and relatively low peel strength. The low peel strength permits the cards **505A-B** to be easily peeled up from the package **500** when the panels **512** and **514** are separated. Alternatively, as desired, the cards **505A-B** may be secured to the package **500** by other conventional methods.

[0029] A rack-hanging hole **540** is defined within the front **512** and rear **514** panels. The two holes **540** are aligned to form a single hole when the package **500** is closed. The rack-hanging hole **40** is used for hanging the package **500** from a conventional display hook (not shown). Obviously, the hole **540** can be eliminated if desired.

[0030] If desired, a transparent window (not shown), such as a transparent plastic film, can be secured in the opening **550** to protect the front surface of the card **505A**. The transparent window may be secured to the front panel **512**.

[0031] As perhaps best illustrated in FIG. 9, the front **512,513** and rear **514, 515** panels are adjoined along a fold line **530**. Alternatively, the front **512** and rear **514** panels can be adjoined along a different edge or can be separate, unconnected pieces. Obviously, the shape of the panels can vary from application to application as desired. For example, the front and rear panels can be different in shape and/or size from each other. Also, the front and/or rear panels can include embossing in the shape of the card(s) **505A-B** to help locate the card(s) in the package **500**.

[0032] Referring now to FIG. 9, the package **500** is manufactured from a conventional die cut paperboard blank. The desired printed information can be applied to the blank either before or after the die cutting operation. The blank is cut with front **512** (and its interior side **513**) and rear **514** (and its interior side **515**) panels adjoined along fold line **530**. The fold line **530** can be scored or partially cut during die cutting process to facilitate the formation of a straight consistent fold. The front panel **512** is also die cut with opening **550**. As noted above, the opening **550** is preferably smaller than the card **505A-B**. The rear panel **514** is die cut

with cut lines **518** that define access flap **516** and access panel **520**. Also printed on interior side is card number **510C**, which corresponds to card numbers **510A-B** of the debit cards **505A-B**.

[0033] As best seen in FIG. 6, the cut lines **518** may include intermittent bridges that hold the access flap **516** and access panel **520** closed. As noted above, in some applications, the intermittent bridges **518** may be eliminated. Crease lines **519** may also be formed in the rear panel **514** during the die cutting step to facilitate a clean, straight fold of the access flap **516**. The crease or score lines **519** can be eliminated, if desired, and the fold line can be defined as the access flap **516** is opened. In addition, the rack hanging holes **540** are cut in the panels **512** and **514** during die cutting to permit the package to be hung for display from a conventional display hanger (not shown). Alternatively, the front **512** and rear **514** panels can be die cut as separate elements or they can be adjoined to each other along a different edge. The term "retention means" as used in the claims shall include not only intermittent bridges, partial cut lines, perforations and other weakened lines, but shall also include, without limitation, the inherent tendency of the panel to resist folding or bending.

[0034] Once the package **500** is die cut, a peelable adhesive is applied to an interior surface of the package **513,515** using conventional techniques and apparatus. Alternatively, the adhesive can be applied to the cards **505A-B**. The cards **505A-B** are then secured to the package **500** by placing them into position on the package **500**. The cards **505A-B** can alternatively be secured by adhesive tape, double sided tape or other conventional securing mechanisms.

[0035] A layer of adhesive or cement is then applied to either or both of the interiors front **513** and rear **514** panels using conventional techniques and apparatus. The package **500** is then folded along fold line **530** using conventional folding machinery to complete the package **10**. The cement secures the panels **512** and **514** in the folded position.

[0036] Alternatively, the cement can be eliminated and the front **512** and rear **514** panels can be sealed together using an alternative technique. For example, the two panels can be secured by a heat-activated adhesive that is pre-applied. When a heat-activated adhesive is used, the two panels are folded and then sealed together by selectively applying heat and pressure to the panels.

[0037] As a second example, the front **512** and rear **514** panels can be secured by applying a layer of peelable adhesive to the entire face of either or both of the front **512** and rear **514** panels, except the access flap **516**. In this embodiment, the layer of peelable adhesive secures the panels together and secures the card to package **500**.

[0038] In the completed package **500**, the cemented front **512** and rear **514** panels entrap cards **505A-B**, with card **505A** visible through opening **550**. Prior to purchase, for example, when the package **500** is on display, the cards **505A-B** are in an inactive state, and the access flap is in the closed position. When the cards **505A-B** are purchased, it is necessary to activate the cards **505A-B**. The activation process is well known and will not be described in detail. Suffice it to say that the cards **505A-B** are activated by reading the activation information encoded on the magnetic strip **511B** and communicating that activation information to an activation device (not shown). The activation device activates the cards **505A-B**.

[0039] To activate a card 505B (and associated card 505A), it is necessary to obtain access to the magnetic strip 511B. Access to the magnetic strip 511B is obtained by applying a force to the access flap 516 to separate it from the rear panel 514. Once sufficient force is applied, the cut line 518 is ruptured or broken and the access flap 516 is free to swing rearwardly away from the package 500. The access flap 516 is then swung rearwardly into the open position substantially perpendicular to the plane of the package 500. In use, the secured card 505B stays within the package 500. The access flap 516, which initially covers the magnetic strip 511B, swings rearwardly and out of the way as the card 505B and magnetic strip 511B are exposed. The exposed strip 511B can then be passed through a conventional magnetic strip card reader (not shown), to provide activation information, while the card 505B remains attached within the package 500.

[0040] Once the card 505B (and 505A) is activated, PIN 525 printed on the access flap 516 may be used to initiate a load transaction to load a stored value to the card 505B (i.e., to an account associated with the card number).

[0041] Access flap 516 can be returned to the closed position by manually swinging the Access flap 516 back into a substantially closed position without substantially deforming the appearance of the package 500. The access flap 516 will generally partially close by virtue of its inherent tendency to return to the closed position. As a result, the access flap 516 also helps to hide the PIN 525 from inadvertent exposure.

[0042] Eventually, it will be desirable to remove the cards 505A-B from the package 500 so that they can be easily carried, for example, in a wallet. To remove the cards 505A-B, the access panel is opened along cut lines 518 to provide easy access to the cards 505A-B. The cards 505A-B are separated from the access panel 520 by simply peeling the cards 505A-B up from the peelable adhesive to separate it from the access panel 520. The low peel strength of the peelable adhesive permits relatively easy removal of the cards 505A-B.

[0043] The foregoing descriptions disclose various embodiments of the present invention in which the access flap 516 is hinged or foldably joined to the panel along its adjacent to card 505B. In alternate embodiments, the access flap can alternatively be hinged or foldably joined to the panel along other edges.

[0044] Although specific embodiments have been illustrated and described herein, it will be appreciated by those of ordinary skill in the art and others, that a wide variety of alternate and/or equivalent implementations may be substituted for the specific embodiment shown and described without departing from the scope of the present invention. This application is intended to cover any adaptations or variations of the embodiment discussed herein. Therefore, it is manifested and intended that the invention be limited only by the claims and the equivalence thereof.

What is claimed is:

1. A debit card package, comprising:

a first panel defining a first plane and including an access flap joined to said first panel along a score line, said access flap being selectively pivotal in a single direction about said score line such that said package is

selectively movable between a closed position in which said access flap is in substantial alignment with said first plane and an open position in which said access flap is swung out and away from said first panel along said score line so that said access flap is substantially outside of said first plane and defines a second plane distinct from said first plane;

said access flap having an interior surface including identification indicia on said interior surface, said identification indicia being exposed and observable when said package is in said open position; and

a debit card removably secured within the debit card package, said debit card having a activation portion, said activation portion being exposed and capable of being activated when access flap package is in said open position.

2. The debit card package of claim 1, further comprising a retention means for providing resistance against movement of the access flap out of the first plane.

3. The debit card package of claim 2, wherein the retention means comprises at least one bridge.

4. The debit card package of claim 1, further comprising an opening disposed on a surface of a second panel to permit viewing of a portion of said a surface of said debit card, wherein said opening disposed in said second panel is slightly smaller than perimeter dimensions of said debit card so that said first panel provides resistance to removal of said debit card.

5. The debit card package of claim 1, wherein said access flap is defined by at least one cut line; and said access flap temporarily retained in said first position by at least one bridge.

6. The debit card package of claim 5, wherein said first panel and said access flap substantially cover a surface of said debit card when said card said access flap is in said first position.

7. The debit card package of claim 1, wherein the first panel is defined as a rear panel, the package further comprising a front panel;

the rear panel interconnected with said front panel, an access flap retention means present on said rear panel for providing resistance to movement of said access flap out of the first plane;

the debit card disposed between said front panel and said rear panel; and

said access flap rearwardly moveable away from said front panel.

8. The debit card package of claim 7, wherein said debit card can be viewed through an opening disposed within said front panel when said package is in a closed position, said opening being similar in shape to, but smaller than, the periphery of said debit card whereby said debit card is prevented from passing through said opening.

9. The debit card package of claim 7, wherein said identification means is observable when said package is in said open position.

10. The debit card package of claim 7, wherein said debit card is secured to said rear panel by a peelable adhesive.

11. The debit card package of claim 7, wherein said debit card is secured to said front panel by a peelable adhesive.

12. The debit card package of claim 7, wherein said access flap is defined by at least one cut line, said access flap temporarily retained in substantial alignment with said first plane by at least one bridge.

13. The debit card package of claim 1, wherein said debit card having an associated pin number, said pin number printed on said package and hidden from view when said package is in said closed position.

14. The debit card package of claim 13, wherein said pin number is printed on said access flap.

15. The debit card package of claim 1, wherein said first panel comprises a display hole for hanging said package at a point of display.

16. The debit card package of claim 7, wherein said front panel and said rear panel each include a respective side edge said front panel and said rear panel being integrally connected at said edges along a fold line.

17. A method for activating a packaged debit card, comprising the steps of:

providing a package with a debit card disposed on a panel, the panel including a access flap that is pivotal about a fold line, the package including retention means for temporarily retaining the access flap in a plane defined by the first panel, the card being secured within said

package, the card including an identification means for identifying the card for activation purposes;

applying a force to the access flap to overcome the retention means;

swinging the access flap into an open position out of the plane defined by the first panel;

reading the identification means while the access flap is in the open position and while the card remains within said package; and

activating the card in an activation device based on the identification means.

18. The method of claim 17 wherein the retention means is defined as at least one bridge, said applying step including applying sufficient force to the card through the opening to break the bridge.

19. The method of claim 17, further comprising observing a pin number associated with said debit card packaged within said debit card page.

20. The method of claim 19, further comprising loading a value onto said debit card utilizing said pin number.

* * * * *