

[54] ELECTRONIC DIGITAL CLOCKS

3,672,155 6/1972 Bergey et al. 58/50 R
3,691,755 9/1972 Girard 58/50 R

[75] Inventor: Mikiharu Tanji, Omattacho, Japan

[73] Assignee: ISE Electronics Corporation, Ise City Mie, Prefecture, Japan

Primary Examiner—Edith Simmons Jackmon
Attorney, Agent, or Firm—Dike, Bronstein, Roberts, Cushman & Pfund

[22] Filed: July 24, 1973

[21] Appl. No.: 382,271

[52] U.S. Cl. 58/50 R, 340/336

[51] Int. Cl. G04b 19/30

[58] Field of Search 58/23 R, 50 R; 340/324, 340/336

[57] ABSTRACT

In an electronic digital clock wherein letters representing the time and a symbol PM or AM are displayed by luminous display tubes driven by an electronic driving circuit, the brightness of the luminous display tubes is varied by a photoelectric element responsive to the brightness of the ambient light.

[56] References Cited
UNITED STATES PATENTS

2,542,021 2/1951 Fox 58/50 R

1 Claim, 3 Drawing Figures

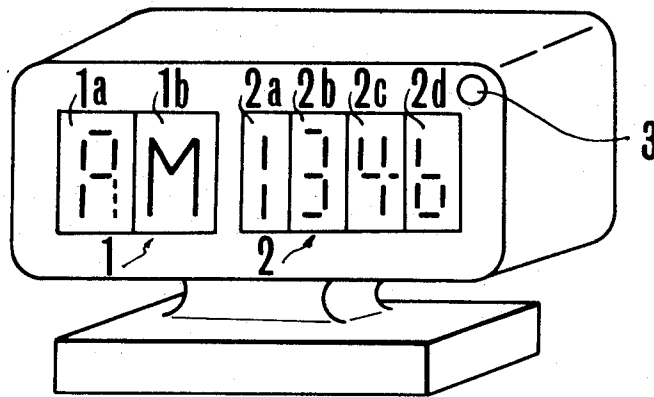

FIG. 1

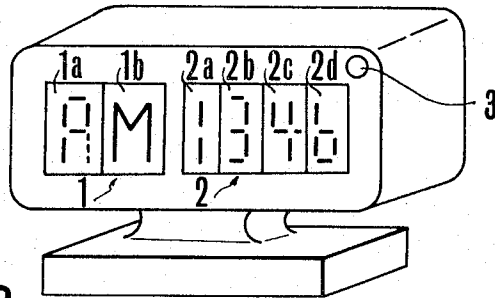

FIG. 2

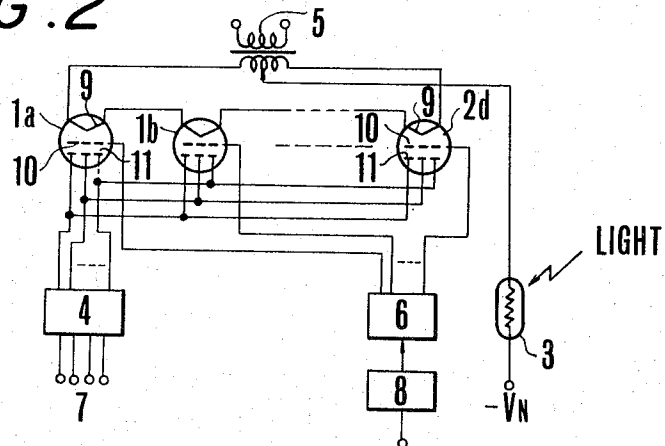
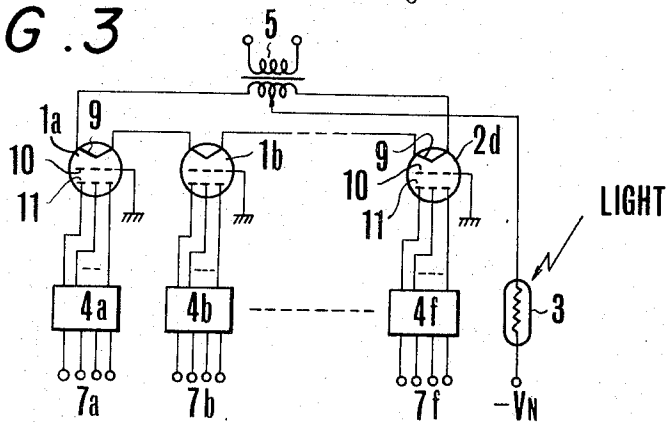

FIG. 3



ELECTRONIC DIGITAL CLOCKS

BACKGROUND OF THE INVENTION

This invention relates to an electronic digital clock, more particularly to a digital clock wherein the digits indicating the time are displayed by luminous digit display tubes and the brightness of the luminous digits is varied in accordance with the brightness of the ambient light.

In the prior art digital clock, since the digits or letters displayed by the display tubes have constant brightness they look too bright or too dark except for a narrow range of the brightness of the ambient light.

SUMMARY OF THE INVENTION

It is an object of this invention to obtain a novel electronic digital clock which can eliminate the difficulty described above.

According to this invention there is provided a digital clock of the type wherein symbols are displayed by luminous display tubes driven by an electronic driving circuit characterized in that there is provided means responsive to the brightness of the ambient light for varying the brightness of the luminous display tubes.

The means responsive to the brightness of the ambient light comprises a photoelectric element which varies its resistance in accordance with the brightness of the ambient light such as a Cds element or a phototransistor which is connected to vary the bias potential applied to the cathode electrodes of the luminous display tubes.

BRIEF DESCRIPTION OF THE DRAWINGS

In the accompanying drawing:

FIG. 1 shows a perspective view of a digital clock to which the invention may be applied;

FIG. 2 shows a connection diagram for varying the brightness of the displayed letters in accordance with the teaching of this invention and

FIG. 3 shows a modified embodiment of this invention.

DESCRIPTION OF THE PREFERRED EMBODIMENT

The digital clock illustrated in FIG. 1 comprises an AM (forenoon) — PM (afternoon) display section 1 provided with two luminous display tubes 1a and 1b, — a time display section 2 provided with four digit display tubes 2a, 2b, 2c and 2d and a photoelectric element 3 for detecting the brightness of the ambient light. Where visible light is to be detected such photoelectric element as a Cds element is suitable but it should be understood that any other type of photoelectric converter may be used such as a phototransistor.

As is well known in the art, display tubes 1a, 1b, 2a — 2d utilized in this invention are fluorescent tubes wherein phosphors are caused to luminesce by the heat energy radiated from cathode electrodes. Luminous tube 1a comprises six luminous segments arranged in a letter A configuration and either letter A or P is selectively displayed by energizing or not one of the segments shown in dotted line. Display tube 1b comprises a single electrode in the form of a letter M, and each of the display tubes 2a through 2d comprises seven luminous segments arranged in the form of a letter 8 and by selective energization of these seven segments one

of ten digits of from 0 to 9 inclusive can be displayed as is well known in the art. It is a feature of this invention to control the bias potential impressed upon the cathode electrode in accordance with the brightness of the ambient light.

FIG. 2 shows one example of an electronic driving circuit for the digital clock shown in FIG. 1, which comprises a combined decoder and segment driver 4 provided with a plurality of terminals 7 connected to receive time signals, each consisting of a four bit binary code, an input transformer 5, a grid driver 6 and a counter 8. The luminous display tubes 1a, 1b . . . 2d are provided with cathode electrodes 9 which are connected in series across the secondary winding of the input transformer 5, grid electrodes 10 and luminous segments or anode electrodes 11. As shown, the photoelectric element 3 is connected to the midpoint of the secondary winding of the input transformer 5.

In operation, the 4 bit binary codes impressed upon input terminals 7 are decoded by the decoder and then applied to appropriate ones of the luminous segments 11. The output of the counter 8 is applied to grid electrodes 11 of the luminous tubes through grid driver 6 to energize suitable grid electrodes in accordance with the content of the counter 8. Accordingly, either one of letters PM and AM and the digits representing the present time, for example, 13 hours 46 minutes are displayed.

In response to the brightness of the ambient light, the photoelectric element 3 changes its resistance thus varying the bias potential applied upon the cathode electrodes 9 of respective luminous display tubes. For this reason, it is possible to vary the brightness of the digits or letters displayed by the luminous display tubes in accordance with the brightness of the ambient light.

FIG. 3 shows a modified electronic driving circuit which is different from that shown in FIG. 2 in that instead of providing grid driver 6 and counter 8, combined decoder and segment drivers 4a through 4f respectively provided with input terminals 7a through 7f respectively are provided for respective luminous display tubes. This modification operates in the same manner as that shown in FIG. 2.

Although, in the embodiments shown in FIGS. 2 and 3 the photoelectric element 3 was connected to the midpoint of the secondary winding of the input transformer 5, it will be clear that the photoelectric element 3 can also be connected to the midpoint of serially connected cathode electrodes of the luminous digit tubes.

As above described, the invention provides a novel digital clock wherein the brightness of the digit or letters is varied automatically in accordance with that is in proportion to, the brightness of the ambient light so that it is possible to obviate the previously described difficulty of the prior art digital clock.

What is claimed is:

1. In an electronic digital clock of the type wherein letters are displayed by luminous display tubes driven by an electronic driving circuit, the improvement which comprises each of said luminous display tubes having a cathode electrode, a grid electrode and a plurality of luminous electrodes which are arranged to display a predetermined letter and are driven by time signals produced by said electronic driving circuit, and means responsive to the brightness of the ambient light for varying the brightness of said luminous display tubes including a photoelectric element connected for each said tube to said cathode electrode to vary its bias potential.