



US00D856887S

(12) **United States Design Patent**
Imazato

(10) **Patent No.:** **US D856,887 S**

(45) **Date of Patent:** **** Aug. 20, 2019**

- (54) **WHEEL**
- (71) Applicant: **HONDA PATENTS & TECHNOLOGIES NORTH AMERICA, LLC, Torrance, CA (US)**
- (72) Inventor: **Makoto Imazato, Asaka (JP)**
- (73) Assignee: **HONDA PATENTS & TECHNOLOGIES NORTH AMERICA, LLC, Torrance, CA (US)**
- (**) Term: **15 Years**
- (21) Appl. No.: **29/642,277**
- (22) Filed: **Mar. 28, 2018**
- (51) **LOC (12) Cl.** **12-16**
- (52) **U.S. Cl.**
USPC **D12/209**
- (58) **Field of Classification Search**
USPC D12/204–213
CPC B60B 7/00; B60B 7/02; B60B 7/04; B60B 7/01; B60B 7/06; B60B 3/04; B60B 1/00; B60B 3/10; B60B 1/10; B60B 1/08; B60B 3/06; B60B 1/12; B60B 3/02
See application file for complete search history.

D709,427 S *	7/2014	Clottu	D12/209
D748,031 S	1/2016	Miyazawa	
D757,626 S	5/2016	Bridan et al.	
D761,711 S	7/2016	Wolf et al.	
D762,543 S	8/2016	Hara	
D763,760 S *	8/2016	Gale	D12/209
D774,434 S *	12/2016	Nakahara	D12/209
D782,953 S *	4/2017	Imazato	D12/209
D788,003 S	5/2017	Conforzi et al.	
D789,862 S	6/2017	Yoneyama et al.	
D791,668 S	7/2017	Murase	
D792,306 S	7/2017	Ishigaki	
D795,155 S	8/2017	Valencia Pollex	
D797,023 S	9/2017	Rueckheim	

(Continued)

Primary Examiner — Stacia A Cadmus

(74) *Attorney, Agent, or Firm* — Arent Fox LLP

(57) **CLAIM**

The ornamental design for a wheel, as shown and described.

DESCRIPTION

FIG. 1 is a front left perspective view of a wheel showing my new design;
 FIG. 2 is a front right perspective view of the design shown in FIG. 1;
 FIG. 3 is a rear left perspective view of the design shown in FIG. 1;
 FIG. 4 is a rear right perspective view of the design shown in FIG. 1;
 FIG. 5 is a front view of the design shown in FIG. 1;
 FIG. 6 is a rear view of the design shown in FIG. 1;
 FIG. 7 is a left side view of the design shown in FIG. 1;
 FIG. 8 is a right side view of the design shown in FIG. 1;
 FIG. 9 is a top view of the design shown in FIG. 1; and
 FIG. 10 is a bottom view of the design shown in FIG. 1.
 The broken lines shown in the figures are included for the purpose of illustrating portions of the wheel and form no part of the claimed design.

1 Claim, 10 Drawing Sheets

(56) **References Cited**

U.S. PATENT DOCUMENTS

D486,769 S *	2/2004	Gallert	D12/209
D506,717 S *	6/2005	Gallert	D12/209
D586,283 S	2/2009	Chung	
D629,346 S	12/2010	Szews	
D649,503 S *	11/2011	Platto	D12/209
D673,100 S *	12/2012	Mueller-Stolz	D12/211
D685,709 S *	7/2013	Hanaoka	D12/209
D695,185 S	12/2013	Juergens et al.	
D695,186 S	12/2013	Pollmann	
D695,187 S *	12/2013	Mielke	D12/209
D706,194 S	6/2014	Hanaoka	

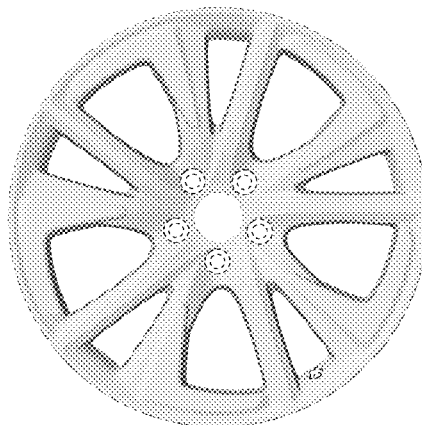
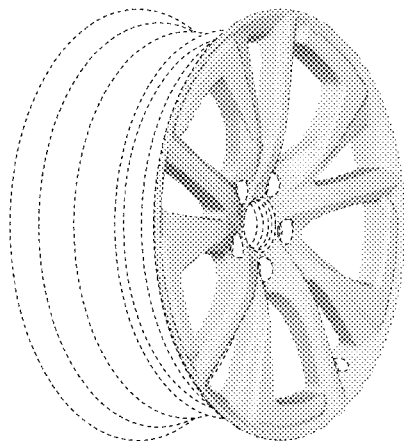

(56)

References Cited

U.S. PATENT DOCUMENTS

D798,217 S	9/2017	Valencia Pollex	
D803,132 S	11/2017	Okaji	
D805,457 S	12/2017	Setter et al.	
D808,324 S	1/2018	Ninov et al.	
D808,884 S	1/2018	Chung	
D809,447 S	2/2018	Wolff et al.	
D811,979 S	3/2018	Svensson et al.	
D818,925 S *	5/2018	Sugiyama	D12/209
D822,574 S *	7/2018	Rucigaj	D12/209
D826,826 S *	8/2018	Back	D12/209
D839,812 S *	2/2019	He	D12/209

* cited by examiner

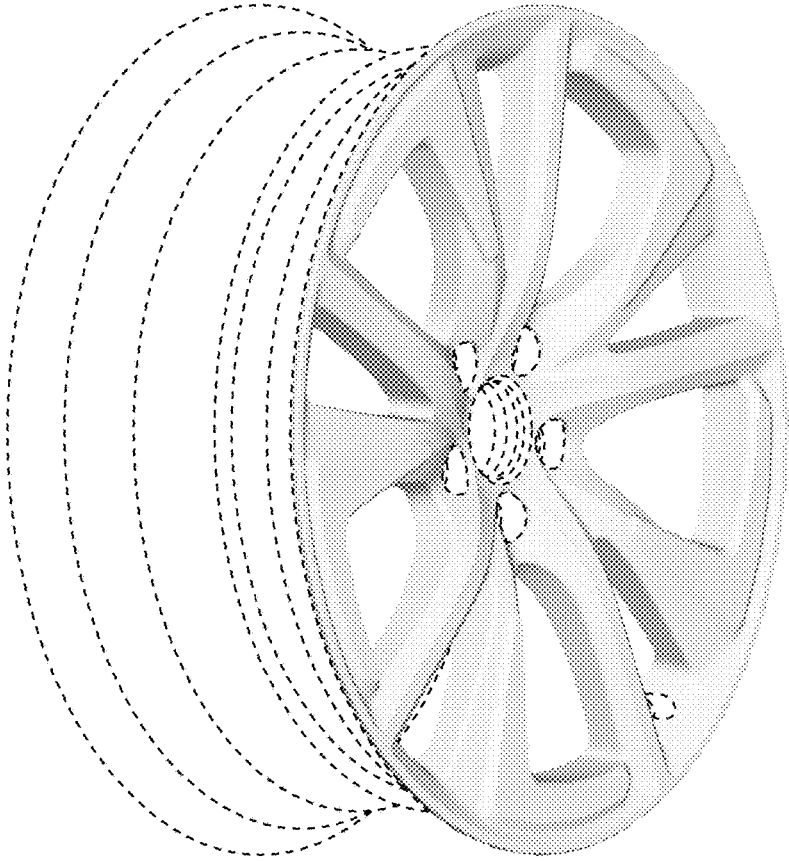

FIG. 1

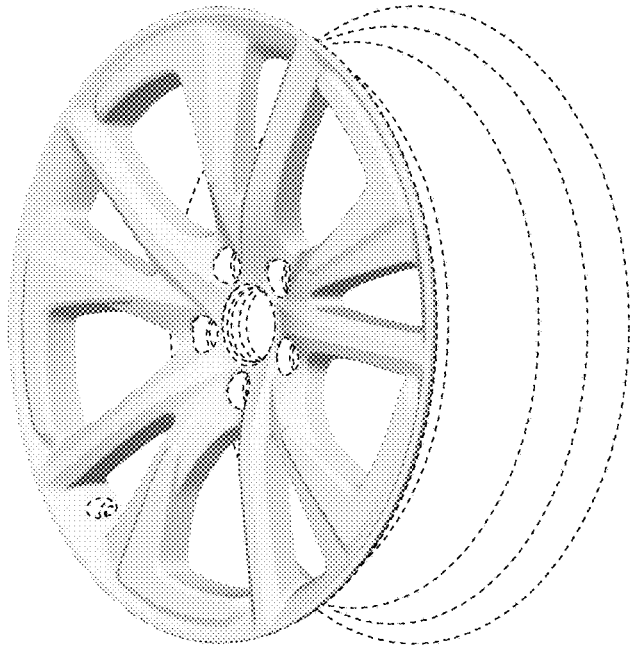

FIG. 2

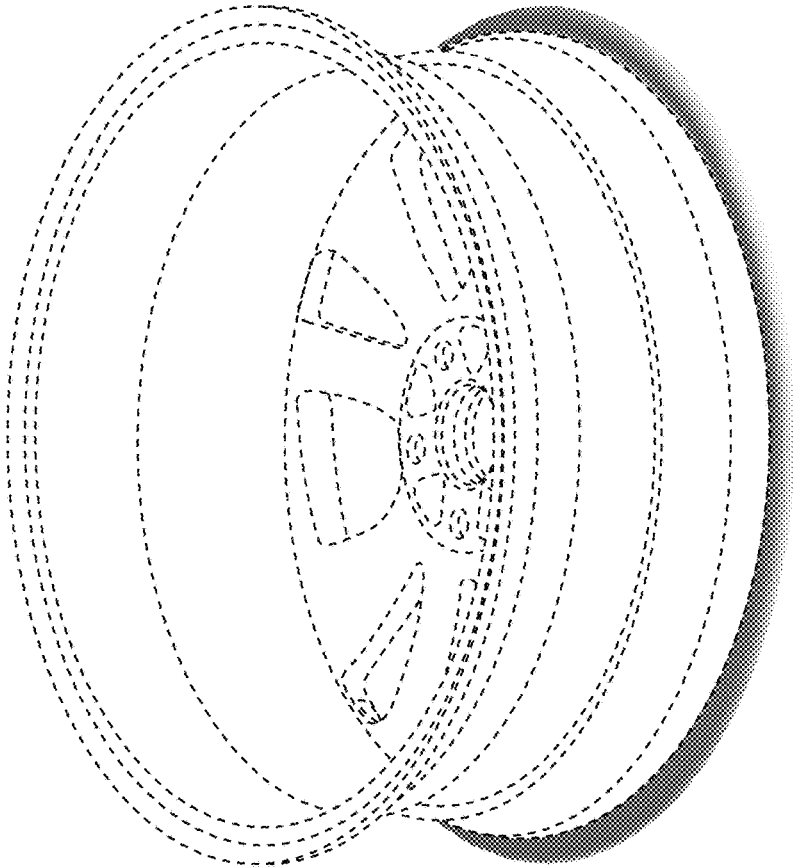

FIG. 3

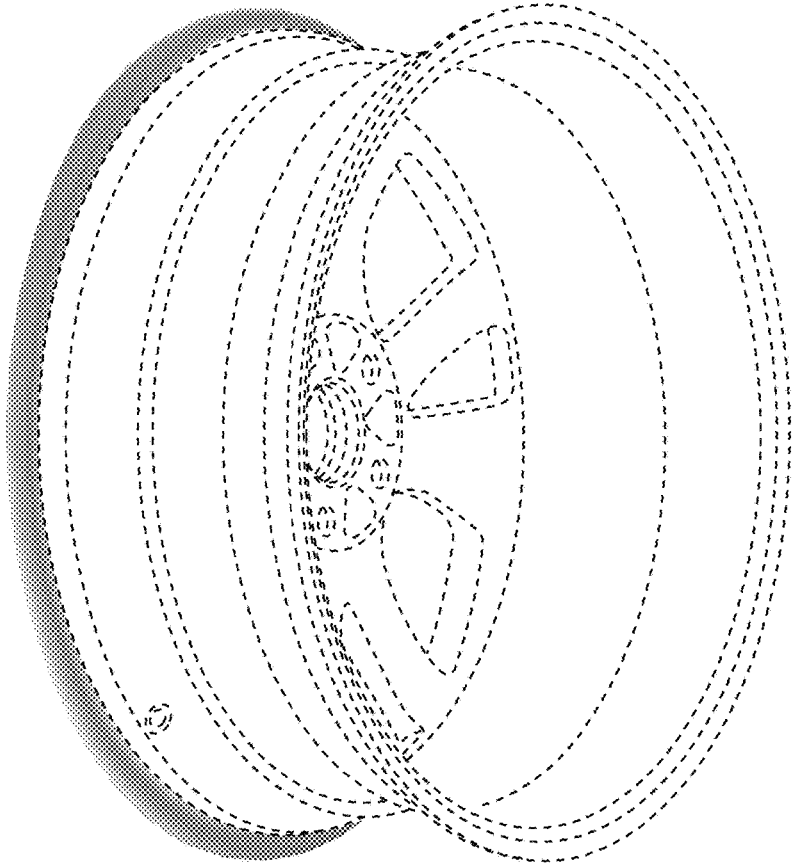

FIG. 4



FIG. 5

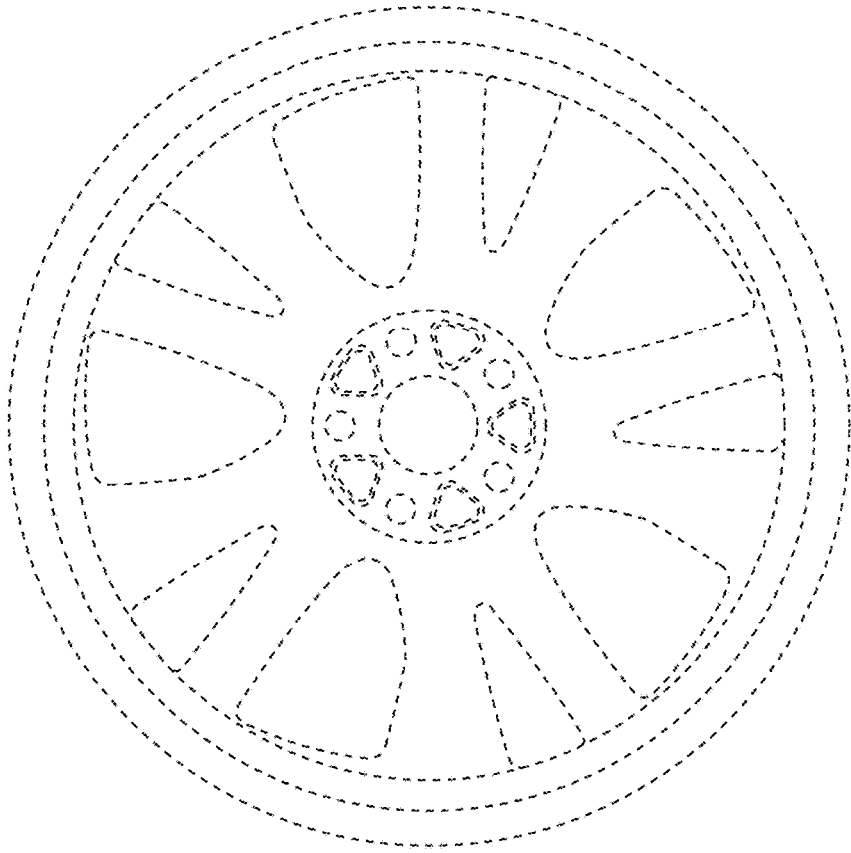

FIG. 6

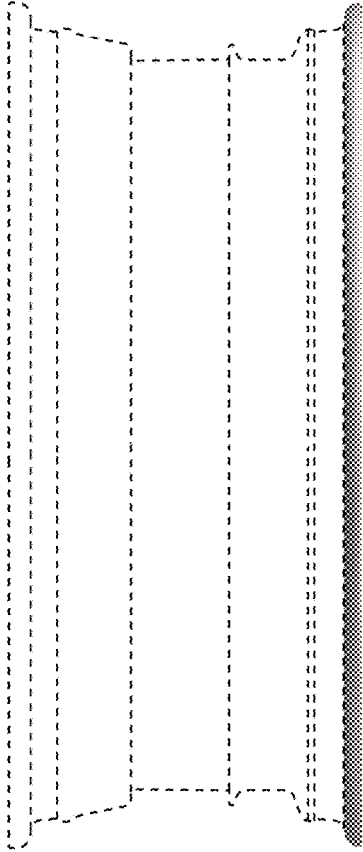

FIG. 7

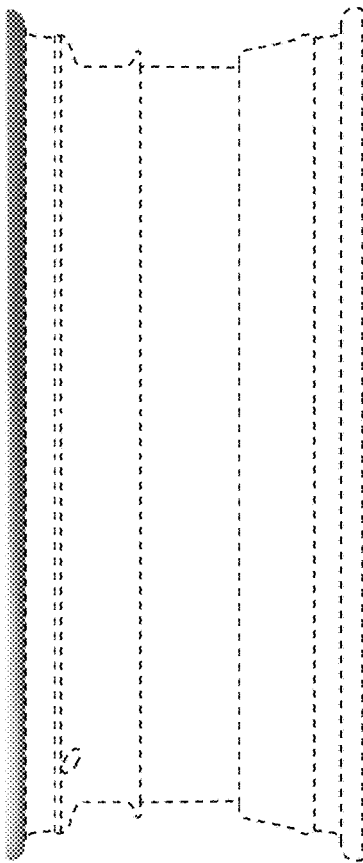

FIG. 8

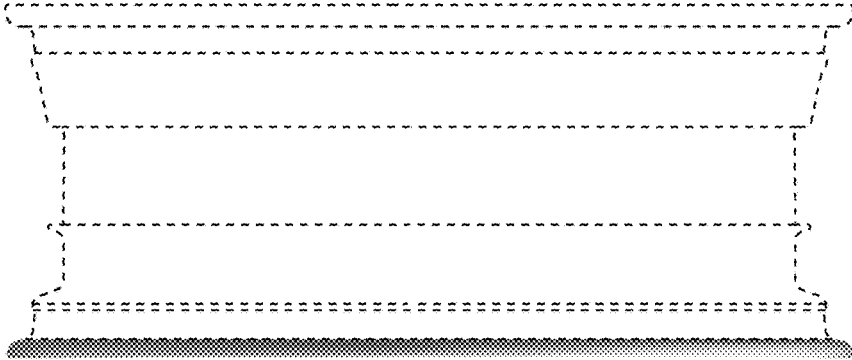

FIG. 9

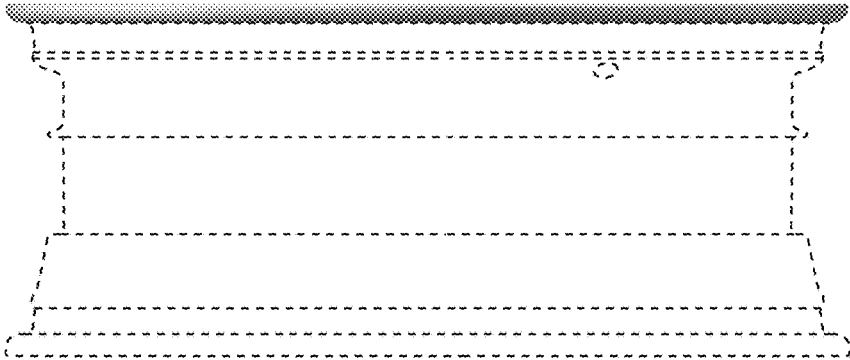

FIG. 10