

FOR THE PURPOSES OF INFORMATION ONLY

Codes used to identify States party to the PCT on the front pages of pamphlets publishing international applications under the PCT.

AT	Austria	LI	Liechtenstein
AU	Australia	LK	Sri Lanka
BE	Belgium	LU	Luxembourg
BR	Brazil	MC	Monaco
CF	Central African Republic	MG	Madagascar
CG	Congo	MR	Mauritania
CH	Switzerland	MW	Malawi
CM	Cameroon	NL	Netherlands
DE	Germany, Federal Republic of	NO	Norway
DK	Denmark	RO	Romania
FI	Finland	SE	Sweden
FR	France	SN	Senegal
GA	Gabon	SU	Soviet Union
GB	United Kingdom	TD	Chad
HU	Hungary	TG	Togo
JP	Japan	US	United States of America
KP	Democratic People's Republic of Korea		

- 1 -

DescriptionProsthesis Fixation To BoneTechnical Field

5 The present invention relates to the fixation, or fastening, of artificial joints or other prosthesis, including dental implants, to bone without the use of a cement or grouting agent.

Background Art

10 Presently, orthopedic surgeons most commonly use polymethyl methacrylate (PMMA) cement for fixing artificial joint components to bone. This technique has the advantage that high fixation strength is attained immediately postoperatively. The patient can undertake physical activity involving the newly implanted joint within a few days postoperatively. This is beneficial
15 for the patient's physical well-being because it stimulates circulation and respiration.

However, joint implantation using the PMMA cement has not been entirely satisfactory in the long
20 term. Artificial joints, and their fixation, must withstand large mechanical forces. Especially so in the weight bearing joints: hip, knee and ankle. Transfer of these large mechanical forces from the prosthetic joint to the bone is through a complex
25 structural system when cement is employed. The tensile and compression strengths and the moduli of elasticity vary greatly among the elements in this system: bone, cement and prosthesis, which is commonly metal. The cement is the least strong and the most flexible of the
30 three, and cement is also subject to brittle failure.



- 2 -

Failure of prosthetic joint implants is often traceable to failure in the cement fixation. Many hip femoral prosthesis stems have fractured after the supporting cement interface has failed in one way or another.

5 Because of the demonstrated long-term inadequacy of prosthetic fixation using cement, it has been a continuing objective to achieve direct fixation between the prosthetic structural component and bone. Numerous attempts to achieve this goal have been made
10 over many years. Investigators have employed or proposed:

- metal components press fit impacted into prepared bone canals or cavities. These components were tapered pins with both smooth or irregular
15 surfaces, acetabular cups with "petals" or teeth for cutting into the bone, stems with sintered porous metal surfaces. See, for instance, U.S. Patent No. 3,996,625 to Noiles.

- metal components with porous plastic coatings of several kinds.
20

- metal components coated with a biologically active and aseptic glassy material, sometimes called a "bioglass" coating.

- porous plate elements have been tried but
25 their mechanical strength is very low.

- ceramic components with and without porous or threaded surfaces, and with biologically active ionic surface treatments.

- metal components with threaded stems, and
30 threaded ceramic acetabular cups.

Use of most of the above structures and methods does not permit the initial implantation to achieve intimate mechanical load transmitting relationships between the prosthesis and bone. That is, they



- 3 -

are intended to permit bone ingrowth into the porosities or irregularities of the surface of the prosthesis. This bone ingrowth phenomenon is reported to take place in about one to five months in order to achieve adequate structural strength for patient physical activity involving the affected joint. During this time the prosthesis-to-bone interface must be maintained without motion, because it is known that motion at this interface will cause the body to develop soft non-bony tissue at this interface which provides inadequate support for the prosthesis. Therefore, most of the above proposed techniques anticipate restricted patient activity for extended periods. Such restricted activity is not desired for reasons of the patient's overall physical health.

The threaded prosthetic stem concept can provide initial intimate load bearing prosthesis-to-bone interface. However, the threaded stem has surface discontinuities which severely reduce the fatigue endurance strength of the prosthetic component. There are additional difficulties in screwing into the prepared bony canal or cavity the entire prosthetic component to achieve the correct depth of insertion and angle of orientation. For instance, a part of the prosthesis may interface with a part of the bone when attempting to screw the prosthesis into position.

Results of recent experience with prosthetic joint components with porous metal surfaces which foster bone ingrowth have confirmed that bone reshapes and redensifies itself, by a behavior called "remodeling", to suit the path of load transmission from the prosthesis to the bone. This same experience also demonstrates that it is desirable to transfer a maximum fraction of the total load as close as possible to the



- 4 -

normal joint surface in order to encourage the retention of a maximum amount of normal bone mass. For example, a femoral stem prosthesis for a hip joint which provides for bone ingrowth at the distal end of the stem may
5 promote load transfer at that part of the prosthesis with the result that the bone adjacent to the proximal part of the stem will not carry a physiological share of the total load and therefore will become less dense and less strong. While a prosthesis so fixed may
10 function satisfactorily, such a biological change is undesired in the event that the femoral stem prosthesis ever has to be replaced, for any of a number of reasons, in which case the surgeon is forced to deal with an abnormally reduced amount of bone stock in the proximal
15 femur.

There are three principles which are generally accepted to apply to the successful fixation of joint prostheses by direct bone contact and support of the prosthesis. One, the prosthesis must be in contact
20 with sound bone. That is, the bone to which force is transmitted by the prosthesis must have adequate strength to support the applied stresses. This implies that the stress applied to the bone will be within the physiological stress carrying capability of the bone. Two, the
25 prosthesis must be a good fit in the prepared bony cavity. And three, there must not be motion between the prosthesis and the bone.

It is clear that the above three requirements are closely interrelated and very much dependent on
30 favorable geometric relationship between the prosthesis and the bone. It must be true that if a patient's joint and bone structure functioned to any reasonable extent prior to implantation of a prosthesis, then the patient's bone quality is somewhere adequate to support



- 5 -

the loads due to that degree of function of that particular joint. The problem then becomes one of providing a prosthesis of the correct shape and size to contact the patient's bone at the optimum interface surface for satisfactory transfer of force from the prosthesis to the bone. Further, the prosthesis must satisfy the above and also fill the space created in the bone with the utmost of congruency in order to inhibit motion between the prosthesis and the bone. It has been reported that bone may grow to fill spaces adjacent the implant of up to 2mm. Certainly, spaces however small between the implants and the bone do not favor the necessary absence of motion therebetween. Because humans vary so remarkably in physical size and shape, we begin to see that each prosthesis should be custom sized and shaped to suit the bone into which it is to be implanted. Aside from the economic cost of providing a custom prosthesis for each joint of each patient, there is an overriding practical impediment to so doing. The exact dimension for an optimum size and shape of prosthesis cannot be determined before the time of surgery when the bone is opened and its true nature is learned.

The truth of the above may be substantiated by the relative success to date of implantation of joint prostheses using polymethyl methacrylate cement. The cement serves the function of providing a custom prosthesis for the individual bone at the time of implantation. The bone is opened, explored, reamed and broached to create a cavity which is surrounded by bone judged by the surgeon to be of adequate strength to support the forces to be received by the bone. The basic prosthesis, usually metal, is available in an assortment of shapes and sizes, perhaps as many as two



- 6 -

dozen. The utilization of PMM cement to fill the spaces between the prosthesis and the bone is, in fact, the creation of a custom prosthesis for that particular implantation. The mechanical properties of the cement
5 are inadequate to provide a satisfactorily high percentage of successful implants for long term use, however.

With regard to dental prosthesis fixation to bone, for more than ten years, attempts to implant devices in human jaw bones where natural teeth are
10 missing have not been successful to the point where even one moderately well-accepted design exists. Experience to date has demonstrated that remodeling of the jaw bone to accommodate the non-physiological stress patterns introduced by the artificial implant
15 generally causes an undesired reduction in the total volume of bone. It is a principal of physiology that bone develops shape and density according to the manner in which load is imposed on it. A change of shape or density on account of a change of loading is called
20 bone remodeling. Further, the loss of bone is generally in that part of the jaw where the implant emerges from the bone to support the artificial tooth, bridge or other dental appliance. This loss of bone is at least partly attributed to the reduced stress in that part of
25 the bone where the implant emerges from the bone. This occurrence has been reported particularly in patients fitted with blade type implants.

Functional loads imparted to a natural tooth or an implant are principally compression and bending.
30 There is little likelihood of any significant torsion load being present. Current practice in implanting dental anchorage devices favors non-loading of the implant for an initial period of 2 to 4 months during which time the bone supporting the implant recovers



- 7 -

from the trauma of the implantation procedure. This has been conveniently accomplished by using a two or more part device, where the bone anchorage part is implanted wholly within the jaw bone and the gum
5 tissue is closed over the implant for the initial time period. One surface of the implant is approximately flush with the alveolar ridge of the mandible or maxilla, and through this surface there has been provided a female thread, into which a second part of the prosthesis
10 having a threaded male stem can be fastened when the gum tissue is penetrated for so doing.

The above known implanted parts may be externally smooth or threaded posts or cylinders, or blades. Any of which may be of metal, carbon, plastic or ceramic,
15 either solid or porous, and uncoated or coated with a variety of biologically acceptable materials.

As best understood, all of the above are designed for approximately equal or uniform bony attachment to all imbedded surfaces, and certainly in no
20 instance is there provision for enhanced bony fixation in the area near the alveolar ridge and for less enhanced bony attachment to that part of the implant which extends relatively more deeply into the jawbone, either mandible or maxilla.

25 Accordingly, a primary object of the present invention is to provide means for fastening a load bearing component of an artificial joint prosthesis to the host's bone with high initial fastening strength while also permitting the critical structural load
30 bearing components to have generous physical dimensions and smooth exterior contours where necessary for their having high fatigue endurance strength.

A further object of the present invention is to provide means for fastening a load bearing component



- 8 -

of an artificial joint prosthesis to the host's bone in a manner which accommodates a pattern of load transfer from the prosthesis to the bone where a maximum fraction of the total load is transferred to that part of the bone nearest the normal joint surface, by which the prosthetic component provides increased interface load transmitting area of contact with the bone at this subject area. An additional object is to provide a system of components for artificial joint prostheses where a number of variations of sizes and shapes for each component can be combined to create a much larger number of combinations in size and shape of prosthesis assemblies and thereby permit the selection of optimum fit between the prosthesis and the bone at the time of surgery. A still further object is to provide a system which facilitates achieving the correct angular position relationship of the load bearing component to bone which is independent of the firmness of seating of the primary fastening means. Yet another object is to provide instruments for preparing the bone to permit prosthesis fastening according to this invention in accordance with present-day orthopedic surgical practice.

It is another primary object of the present invention to provide a dental prosthesis for implantation in the jawbone by which compression load to the prosthesis is transferred primarily to the bone area adjacent to the alveolar ridge in order to maintain and develop sound bone in this critical area by stress remodeling of the bone; while at the same time transferring to the bone, lateral compressive stress reactions to bending loads applied to the implant, 1) as lateral compressive stress at the area adjacent the alveolar ridge and, 2) as lateral compressive stress at an area displaced from the alveolar ridge wherein the above



- 9 -

opposed lateral compressive stresses are within the physiological stress capacity of the jawbone. An additional object is to provide a dental implant where that part implanted within the jawbone immediately adjacent the alveolar ridge has its external bone interface surface area increased by geometric features or surface texture and that part implanted distant from the alveolar ridge lacks features which would increase its surface area. An additional object is to provide the part of a dental implant prosthesis which passes through the gum to be of high endurance strength by making this part to be without external surface discontinuities such as those created by the presently used screw threads. An additional object is to provide a system where the part of the dental implant which passes through the gum can be firmly anchored in any radial angular position. That is, security of fastening is not a function of rotary thread tightening or other limitation.

20 Disclosure of Invention

The present invention for implantation of an artificial joint prosthesis derives from a consideration of the three principal distinct types of force which may be transmitted from a structural component of a joint prosthesis to the host's bone, the recognized desirability of transferring a maximum part of the total load to that part of the bone which is closest to the joint motion surface, and the additional desirability of not using PMMA cement in that part of the bone which is closest to the joint motion surface, while at the same time providing immediate fixation with sufficient initial strength to prevent motion between the prosthesis and the bone during early physical rehabilitation of



- 10 -

the patient. It is further desirable to provide a prosthesis to bone fixation geometry which disrupts the normal physiological blood flow pattern to the minimum possible extent. It is recognized that the strength of
5 fixation will increase with time as the bone remodels itself to accommodate the new stress pattern created by the implantation of the prosthesis if there is no motion between the prosthesis and the bone.

The three principal types of forces transmitted between the prosthesis and the bone are compression, torsion and bending. While tensile forces do
10 exist in the weight bearing bones, they are generally the result of bending. It is highly unlikely that a joint prosthesis would transmit a net tensile force to the bone. Further, the present invention contemplates
15 the transmission of tensile force from the prosthesis to the bone, as will be discussed later.

The invention will be described as embodied in a hip joint prosthesis of the proximal femur although
20 it is applicable to any joint prosthesis including but not limited to those for a shoulder, elbow, wrist, knee, ankle, finger and toe. The hip prosthesis is provided with a stem which extends into the canal of the femur for a distance of approximately 5 to 8 inches,
25 although this could be longer should conditions dictate. The stem carries a collar or flange, transverse to the stem, which abuts the excised proximal end of the femur where the head and neck of the natural femur have been excised for implantation of the prosthesis. Proximal
30 of the collar the prosthesis comprises a neck portion which supports the ball or head of the prosthesis at a distance from the extended centerline of the shaft of the femur.



- 11 -

The stem also carries a number of relatively short longitudinal fins or splines adjacent to the flange on the side of the flange opposite from the hip joint, which fins are, at the time of implantation, embedded in the prepared cancellous bone which exists at the end of the bone adjacent the joint surface. Some of the outer edges of the fins may contact and cut into the inside of the cortical wall of the bone which surrounds the cancellous bone. The side of the flange which is in contact with bone and all of the surfaces of the fins may be coated with a porous sintered metal layer or any other textured or treated surface designed to enhance fixation to bone.

The force of compression is transferred from the prosthesis to the bone principally by means of the collar which abuts the excised proximal end of the femur. The collar is preferably shaped to contact essentially all of the excised surface, which is more or less transverse to the shaft of the bone.

The force applied to the femoral prosthesis is exerted downward on the head of the prosthesis by the acetabulum or socket of the hip joint, and passes through the center of the ball. When the line of action of this force intersects the centerline, or extended centerline, of the femoral canal, or is parallel to this centerline, the forces transmitted from the prosthesis to the bone are limited to those of compression and bending. When the line of action of this force is other than just described, then there is a component of this force which must be transmitted from the prosthesis to the bone as torque. That is, any force applied to the head of the prosthesis whose line of action is not in a plane which contains the centerline of the femoral canal will create a torque about this centerline.



- 12 -

The short longitudinal fins or splines on the stem and emanating from the collar are driven into the prepared cancellous bone of the femur adjacent to the excised surface of the femur to establish a tight fit therein at the same time the collar abuts the excised surface. The numerous fins provide a relatively large surface area through which torque is transmitted from the prosthesis to the bone at that part of the bone closest to the joint surface. The fins act as keys to prevent the prosthesis from rotating about the axis of the shaft of the femur. The applied torque is resisted by compression and shear forces which are distributed throughout a large volume of the cancellous bone.

Finally, the bending component of the force system will be transmitted from the prosthesis to the bone by two opposed forces, one of which acts perpendicular to the centerline of the femoral shaft at the proximal end of the femur, essentially in the area occupied by the finned part of the stem; and the other of which acts perpendicular to the centerline of the femoral shaft at the distal end of the prosthesis. The bending component is a large part of the complete force system, and the forces which constitute the two forces described above will be larger if the distance between them is small.

Preferably the part of the prosthetic stem contained within the bone will be 5 to 8 inches long. This length creates reaction forces to bending which will not exceed the acceptable load capacity of the bone which envelops the stem. Also, it is preferred that the surface of the distal end of the stem not transmit the force components of axial compression or torque from the prosthesis to the bone; therefore, this surface should not be textured, coated or treated to



- 13 -

enhance transfer of shear loads at the surface interface with the bone. It is important that the distal stem fit securely within the femoral canal to prevent any transverse movement between the prosthesis and the bone. It is also contemplated that polymethyl methacrylate cement can be used advantageously to fix the distal prosthesis stem in the canal of the femur. The inventive structure limits the load transfer at this point to a reaction force to bending. That is, the principal stress in cement so used will be in compression between the prosthesis stem and the wall of the canal of the femur. The cement is satisfactory for this type loading. This technique adds to the ability to provide custom fit with a limited number of component sizes.

On the other hand, the surfaces of the collar and the fins are preferably textured, coated or treated to enhance transfer of shear loads at the prosthesis-to-bone interface in this area. It can be seen that such transfer of shear loads will contribute to maximizing the transfer of all three load type components to the proximal bone of the femur. The fins will thus transmit some of the pure compression load as well as some of the compression and tension loads resulting from bending. The underside of the collar can transmit a part of the torque by transmitting shear forces at the collar-to-bone interface. The function of the fins will not be diminished if some of the fins at this outer edge contact the cortical wall of the femur. In fact, this circumstance may be beneficial.

Additionally, it is known that the principal avenues of blood supply within the femur are longitudinal. The longitudinal fins provide the advantage of providing a multitude of paths for stress transfer from prosthesis



- 14 -

to bone in the proximal femur with a minimum disruption of the blood supply within the femur, while also permitting the regeneration of physiologically desirable longitudinal blood paths.

5 Because human bones come in an endless variety of diameter, length, wall thickness, taper, curvature, etc., an alternative construction is proposed which has the greater practical utility. In this alternative
10 embodiment, the collar and longitudinal fins are integral with a thin wall truncated conical sleeve. The large end of the sleeve carries the collar which extends radially outward. The surfaces of the sleeve which
15 contact bone may be textured, coated or treated to enhance fixation to the bone. Or, the entire sleeve may advantageously be made from a suitable porous
 metal.

 With the alternative sleeve embodiment, the femoral component has no collar or fins. The shaft of the stem is smooth and tapered to lock within the
20 sleeve by the well-known principle of mechanical tapers. This embodiment offers the advantage of permitting a variety of size selections for the sleeve component and for the stem component separately. Thus a smaller
25 number of total components is needed to achieve a given number of total size combinations for the final assembly. The two-component embodiment may be more economical to
 manufacture, and will conveniently allow selection of size and implantation of the sleeve before the stem is
 implanted.

30 With either of the above embodiments, one aspect of preparation of the femur consists in reaming the intramedullary canal to a cross-sectional shape and size and to a depth to accept the shaft of the stem of the prosthesis so that the distal part of the prosthesis



- 15 -

will be securely held within the femur without the possibility of transverse motion between the prosthesis and the bone. There must be a selection of sizes of reamers, and a selection of sizes for the distal stem
5 of the prosthesis so that the above condition of fit is obtained. Alternatively or concurrently, use of PMMA cement may be advantageously confined to fixing the distal prosthetic stem in the femoral canal as described above.

10 A second aspect of preparation of the femur consists in creating an essentially transverse surface of the proximal femur against which the collar will abut to lie in a plane which is the same as the plane
15 which the underside of the collar will define when the prosthesis is implanted. A bone cutter and guide can be provided to permit this condition to be obtained. A selection of prosthetic components with varied collar areas must be available so that one can be chosen which
20 will closely match the shape of the bone against which the collar fits. The prosthesis is intended to be implanted with the collar fully seated against the mating bone.

A third aspect of preparation of the femur consists in broaching multiple slots into the cancellous
25 bone of the proximal femur, which slots are to accommodate by press or impacted fit the multiple fins of the prosthesis. A selection of sizes of broaches must be available so that the slots can extend radially as much as the particular femur will allow. A selection
30 of prostheses with various sizes of multiple fin envelopes must also be available to correspond to the several sizes of broaches so that the prepared slots can be filled with fins in tight proximity to cancellous bone, and in some areas the edges of some of the fins



- 16 -

will be in tight proximity to the cortical wall of the femur. If the slots in the bone are each 1.5mm wide, each fin will be somewhat thicker, say 1.6mm to 1.7mm thick, so that the fins must be driven into the slots.

5 In this manner the proximal femur is immediately in a preloaded fit to the prosthesis, and motion between the prosthesis and the bone is prevented during the early physical rehabilitation of the patient. Angular location of the broached slots is made consistent with the
10 desired angular orientation of the neck of the prosthesis in the final implanted condition, if the embodiment requires.

Alternatively, the longitudinal fins can be made self-broaching and a selection of prostheses
15 provided with the volume envelope of the fins increasing in a series of sizes. Successive prostheses are driven into the femur bone and removed to be replaced by the next larger prosthesis until the desired security of fit achieved. This technique is preferred to be used
20 with the thin walled sleeve construction.

Thus the implantation of either embodiment provides initial mechanically strong fixation to resist motion between the prosthesis and the bone which could result from the three principal forces. Motion due to
25 compression is resisted by contact between the collar and the excised surface of the bone, including the cortical margin of the bone, especially the region known as the calcar. Motion due to torque is resisted by the many securely implanted fins in the relatively
30 large volume of cancellous bone in the proximal femur, as well as by some engagement between the edges of some fins and the cortical wall. Motion due to bending is resisted by a large fraction of the fins in the proximal cancellous bone at the one force and reaction area, and

- 17 -

by the secure fit of the distal stem in the femoral canal at the second force and reaction area.

5 The initial fixation is strong enough to prevent motion between the prosthesis and the bone during postoperative recuperation and rehabilitation. As stated above, motion between the prosthesis and the bone will cause the development of soft non-bony tissue which is inadequate to support the prosthesis.

10 The advantages of the prosthesis of this invention are fourfold. One, the prosthesis is designed, sized and installed with immediate load bearing juxtaposition between the several elements of the prosthesis and the associated bone. Bone does not have to grow into the spaces between the fins as it has to grow into
15 the interstices of porous or other irregular surfaces. Two, PMMA cement is not used in the highly loaded part of the bone nearest the joint motion surface. This is the area where the use of cement has proven to be the least successful. Three, with a planned and controlled
20 program of increasing patient activity, the bone remodels itself to accommodate the new force patterns, and the fixation becomes stronger the more it is used. It is to be emphasized that the prosthesis transmits a maximum of load and stress to the bone at the most proximal
25 part of the femur, so that the density and strength of this proximal bone may be preserved. Fourth, the prosthesis creates a minimum disruption of the normal blood supply paths within the proximal femur.

30 Yet another aspect of the present invention is directed to the provision of a thin walled truncated conical sleeve with a smooth inner surface. The outer surface is preferably threaded in the manner of a self-tapping bone screw. The thread is preferably of a high lead, multi-start configuration which permits

- 18 -

rapid advance during insertion in combination with a large number of threads to provide a large load bearing thread area.

Use of self-tapping threads is preferable to prior tapping with a tap, because with self-tapping threads bone chips stay in contact with the threads to fill spaces which are bound to exist due to the irregular and non-homogenous nature of bone, and because these bone chips become nuclei for the growth of new bone in the manner of a bone graft.

The conical taper of the sleeve and the high lead multi-start thread provide a very practical benefit in permitting the sleeve to be screwed home in relatively few turns, preferably fewer than four turns. A sleeve may be two inches long and may have threads in the pitch range of 8 to 25 per inch. A straight single start thread 2 inches long with 25 turns per inch will require 50 turns for full insertion. A tapered single start thread 2 inches long with 25 turns per inch will require a number of turns to seat which depends on the thread depth and taper angle in the following relationship:

$$\frac{\text{depth of thread}}{N \text{ turns} \times \text{advance per turn}} = \text{tangent of angle of taper per side}$$

For example, a 3° taper per side (tangent of .05), a thread depth of .03 inch and a 25 turns per inch single thread will require 15 turns for full engagement. A thread with 5 starts of the same pitch will require only 1/5 as many turns, or 3 turns to attain full thread depth engagement.



- 19 -

The sleeve is screwed into the prepared canal or cavity of the bone to achieve intimate and mechanically strong contact between its threaded outer surface and the bone, and to be in desired axial alignment and depth of position with the bone to accept a load bearing component of the prosthesis.

In one embodiment, the load bearing component of the artificial joint prosthesis fits tightly into the smooth inner conical surface of the sleeve and is locked therein by the well-known principle of mechanical machine tapers, and also extends through the sleeve with a part of the load bearing component extending further into the prepared bony canal or cavity for additional fixation to the bone and stabilization of the prosthesis. In another embodiment, the outer surface is conical, truncated, and preferably threaded. The cone is closed at the small end, and the inner surface may be cylindrical, hemi-spherical or other suitable geometry. The load bearing component of the prosthesis fits within the inner surface of the sleeve and is locked therein by screw threads or other suitable means.

The invention provides immediate intimate structural relationship between the prosthesis and the bone of mechanical strength sufficient that the patient can start limited weight bearing activity within a few days postoperatively. The initial fixation is strong enough to prevent motion between the prosthesis and the bone during postoperative recuperation and rehabilitation. As stated above, motion between the prosthesis and the bone will cause the development of soft non-bony tissue which is inadequate to support the prosthesis.

Because it is a principle of physiology that bone develops shape and density according to the manner



- 20 -

in which load is imposed on it, and because the prosthesis will transmit force to the bone in a manner different from that imposed by the original natural joint, it is true that the bone will have to reshape and redensify itself before the new prosthetic joint to
5 bone fixation attains maximum strength. This is true whenever the pattern of force application to a bone is changed.

The material of the prosthetic sleeve must be
10 biologically acceptable to the development of bone in intimate contact with the sleeve. Preferably the sleeve is made of titanium alloy, specifically an alloy known as Ti6 Al 4V. This alloy is highly resistant to corrosion and is well tolerated by the body. It has
15 high mechanical fatigue endurance strength and a modulus of elasticity, or stiffness characteristic which, while approximately five times greater than that of bone, is approximately half that of other metals commonly used in artificial joint prostheses.

20 With regard to the dental implant there is provided a two-part support for a dental prosthesis, one part of which is implanted entirely within the jawbone. Of the implanted part, that portion adjacent the alveolar ridge has its external bone interface con-
25 tact surface area significantly increased by screw threads, and that portion distant from the alveolar ridge lacks the external thread which increases the bone interface contact surface area of the adjacent portion. The other part, which projects outward from
30 the crest of the jawbone through the gum tissue, fits within the first part and is held therein by a self-locking mechanical taper.

In the preferred two-part embodiment, the part implanted in bone is an elongated hollow tubular



- 21 -

member closed at one end. The outer surface of the closed end is smooth and the outer surface of the open end is threaded in the manner of a self-tapping bone screw. The self-tapping thread is preferred because
5 bone chips created during insertion stay in contact with the threads to fill spaces, which exist due to the porous nature of bone, to become nuclei for the growth of new bone in the manner of a bone graft. The thread may be tapered or straight. The opening in the threaded
10 end of the member provides the female cone of a self-locking taper.

The part which extends outward from the bone, through the gum tissue to support the prosthesis is a pin, stud, or post having three zones. One end of this
15 part is a zone which is the male cone of a self-locking taper which fits within the implanted hollow tubular member. The center zone of this part is a smooth cylinder which extends through the gum tissue. The other end of this part is a zone on which is mounted
20 the prosthetic appliance, bridge or single tooth by any suitable means, as for instance by a second self-locking taper. A single tooth may be fused directly to this other end.

A second embodiment of the dental implant
25 provides a threaded sleeve with a self-locking taper therethrough and a prosthesis supporting post which extends through the sleeve and into direct contact with the bone. The length of the post in contact with the bone has a smooth surface and is at least as long as
30 the threaded sleeve.

A third embodiment of the dental implant provides increased interface contact area with bone by means of multiple longitudinal fins or flutes rather than screw threads. The fins or flutes are preferably
35 self-broaching.



- 22 -

For implantation of each of the above embodiments, the jawbone is prepared by drilling and reaming a hole in the jawbone accurately sized to receive the smooth end of the implant in a tight fit and is also
5 sized to accept the root diameter of the threaded or fluted end of the implant. Thus, the threads or flutes must cut their way into the bone. This action provides immediate intimate structural relationship between the prosthesis and the bone, thereby preventing motion
10 between the prosthesis and the bone during the postoperative period. It has been shown that motion between the prosthesis and the bone will cause the development of soft non-bony tissue which is inadequate to support the prosthesis.

15 As with the artificial joint prosthesis, the implanted material for the dental prosthesis must be biologically acceptable to the development of bone in intimate contact with the prosthesis. Preferably the inventive prosthesis parts are made of titanium or
20 titanium alloy, especially an alloy known as Ti6 Al 4V. These metals are highly resistant to corrosion and are well tolerated by the body. Their strength and stiffness characteristics are appropriate to this use, as is well known.

25 Brief Description of Drawings

FIG. 1 is an oblique view of a femoral prosthesis of an artificial hip joint showing a typical force system acting on a prosthesis of the present invention, including the reaction forces exerted on the
30 prosthesis by the femur;

FIG. 2 is the prosthesis of FIG. 1 showing the force system components acting in the plane through the centerline of the stem and the center of the sphere;

- 23 -

FIG. 3 is the prosthesis of FIG. 1 showing the force system components acting in a vertical plane through the centerline of the stem;

5 FIG. 4 is a general view of an implanted artificial hip joint embodying the teachings of the present invention;

FIG. 5 is a detail view of a prosthesis of the proximal femur showing self-broaching longitudinal flutes according to the present invention;

10 FIG. 6 shows an alternate form of the present invention, used for implantation and fixation of a femoral prosthesis;

FIG. 7 is a plan view of an alternate form of the thin wall fluted sleeve shown in FIG. 6;

15 FIG. 8 is a section view of the sleeve of FIG. 7;

FIG. 9 is another view of the sleeve of FIG. 7;

20 FIG. 10 is a detail view of the femoral prosthesis of FIG. 6;

FIG. 11 is an additional view of the sleeve of FIG. 6;

FIG. 12 shows an impact instrument used for implanting the self-broaching sleeve of FIG. 8;

25 FIG. 13 is a section through the sleeve of FIG. 8 along the line XIII-XIII;

FIG. 14 shows alternative self-broaching flutes on the sleeve of FIG. 8.

30 FIG. 15 shows a hip joint femoral prosthesis stem implantation embodying the teachings of the present invention;

FIG. 16 is a detail view of the sleeve of the present invention, partially in section;



- 24 -

FIG. 17 is a view of a femoral prosthesis embodying the teachings of the present invention;

FIG. 18 shows a reamer used to prepare the femoral canal for the implantation of a femoral prosthesis according to the present invention;

FIG. 19 shows an insertion and alignment instrument used to install the sleeve of the present invention;

FIG. 20 shows a knee joint prosthesis implantation using the present invention;

FIG. 21 is a rear view of the knee joint implantation of FIG. 20;

FIG. 22 shows an alternate form of the present invention used for the implantation of a hip joint acetabular prosthesis;

FIG. 23 is a detail view of the sleeve of FIG. 22, partially in section;

FIG. 24 shows the implantation of a hip joint acetabular prosthesis using an alternate form of the sleeve of FIG. 22;

FIG. 25 shows additional detail of the sleeve of FIG. 24.

FIG. 26 is a perspective view of part of a lower jawbone showing an implant embodying the teachings of the present invention;

FIG. 27 is a sectional view through the implant and jawbone in the plane indicated in FIG. 26;

FIG. 28 is a sectional view in the same plane as FIG. 27, showing a temporary screw plug in place in the tubular member;

FIG. 29 is a sectional view through the jawbone and an implant of an alternate embodiment;

FIG. 30 is a fragmentary perspective view of a lower jawbone showing another alternate embodiment;

- 25 -

FIG. 31 is a section through the implant of FIG. 30 in the plane indicated in FIG. 30; and

FIG. 32 is a sectional view similar to FIG. 27 showing the reaction forces applied to the implant by the jaw bone due to a bending force component applied to a prosthetic tooth.

Best Mode for Carrying Out the Invention

With reference now to the drawings, wherein like references characters designate like or corresponding parts throughout the several views, there is shown in FIG. 1 a diagrammatic representation of a typical force system acting on the femoral prosthesis 10 of an artificial hip joint. The femur 12 is shown inclined at approximately a 30° angle to the horizontal, a position corresponding to that of a person arising from a chair. This discussion will treat static forces only, because they well illustrate the principles involved. Also, the plane through the centerline 14 of the femoral stem 16 and the center of sphere 18 is perpendicular to a vertical plane through centerline 14. Also, for purposes of discussion the reaction forces between the prosthesis 10 and femur 12 are shown acting at a point where they are in fact each distributed over some surface area.

The force F_W being transmitted from the hip joint socket, not shown, to the femur acts vertically downward at the center of the sphere 18. In the vertical plane containing F_W and parallel to centerline 14, F_W can be replaced by two components F_C and F_T , where F_C is parallel to centerline 14 and F_T at 90° to F_C lies in a plane perpendicular to centerline 14.

Reaction forces exerted by the femur 12 on femoral prosthesis 10 in resisting forces F_T and F_C are



- 26 -

assumed to act on centerline 14. These reactions can be analyzed separately and sequentially in the appropriate planes. FIG. 2 shows the reaction forces to F_C acting in the plane through centerline 14 and the line of action of force F_C . Here, F_C can be replaced by F_{C1} acting on centerline 14 and the moment M_1 which equals $F_C \times d$. This system is resisted by the reaction force F_{CB} and a couple whose forces F_{M1} and F_{M2} act perpendicular to centerline 14 at opposite ends of the implanted prosthetic stem as shown. F_{CB} , F_{M1} and F_{M2} are forces exerted on the prosthesis 10 by the femur 12.

In FIG. 3, first consider the forces acting in the plane containing the line of action of force F_T and perpendicular to centerline 14, here force F_T of FIG. 1 can be replaced by its equivalents, force F_{T1} acting perpendicular to centerline 14 at P, and moment M_2 which equals $F_T \times d$. Moment M_2 works on stem 16 of the prosthesis 10 and sets up the equal and opposite reaction moment M_3 exerted by the bone on the prosthesis at the area of interface most resistant to rotation of the stem within the femur 12. This area is specified to be concentrated at point N.

In FIG. 3, next consider the forces in the vertical plane through the line of F_{T1} and the centerline 14, here we show one reaction force F_R to be near the proximal end of femur 12 at point N. A summation of moments reveals that the remaining bone reaction force F_S will vary inversely as the length of stem 16. A summation of forces perpendicular to centerline 14 reveals that reaction force F_R is equal to F_{T1} plus F_S . Therefore, a short stem will cause the greater reaction at F_R and is undesirable.

Again, with reference to FIG. 1 in combining forces F_{M2} and F_S at the distal end of prosthesis 10

- 27 -

graphically, one sees the net reactive force at this point to be F_G . Combining forces F_R , F_{M1} and F_{CB} at the proximal end of prosthesis 10 one sees the net reactive force at point N to be F_H . In addition, one
5 sees that the reaction moment M_3 will exist at the proximal end of the femur 12 provided the prosthesis 10 is designed to transmit torque to the bone at this point, and only this point.

From the above it is clear that the forces
10 and torque which are transmitted from the prosthesis to the proximal femur may be considerably greater than those transmitted at the distal end of the prosthesis. This situation is advantageous if the prosthesis is designed to transmit the larger forces to the proximal
15 bone in a manner which the bone accepts favorably. One thrust of this invention is that the proximal bone will best accept large forces from the prosthesis when the prosthesis is configured so as to diffuse or dissipate large forces into a large volume, or against a large
20 area, of bone, both cancellous and cortical. When these large forces are so diffused to load the proximal bone of the femur within its normal physiological stress limits, the bone will respond by maintaining an adequate volume and density or by remodelling to have a
25 volume and density which is greater than that attained over time with prior art devices.

FIG. 4 shows a femoral prosthesis 10 of an artificial hip joint implanted in femur 12 according to the teachings of the present invention. Preparation of
30 the femur 12 includes excising the neck of the femur at a surface which will abut the undersurface 24 of collar 22 when the prosthesis is implanted, reaming and broaching the femoral canal to accept the stem 16 of the prosthesis, and broaching slots in the proximal cancellous

- 28 -

bone of femur 12 to accept the longitudinal fins 26 which extend distally on stem 16 from collar 22. Fins 26 may alternatively be termed as ribs, splines, flutes, keys, etc., as long as the result is an external
5 geometric pattern of elongated projections.

The fins 26 have a thickness as small as is reasonable to manufacture and handle without damage, approximately in the range from 0.5 to 2mm. The fins 26 have a height of at least 0.7mm and the spaces between
10 the fins are approximately 1 to 4mm. It is to be emphasized that the fins provide a primary force transmitting interface of this invention, and that this is different from the bone-to-prosthesis interface of the so-called bone ingrowth concepts using porous materials,
15 because according to the invention interdigitation is created at the time of implant, and the bone projections within the geometric envelope of the surface of the finned part of the prosthesis have a minimum width of 1mm and a minimum height of approximately 0.7mm.
20 Further, these bone projections have a length dimension longitudinally of the fins of 10 or more times their width. That is, their length may be 10, 20, 30mm or more. Further still, in the annulus space 52 in FIG. 13 where bone and fins are interdigitated when the prosthesis
25 is implanted, the ratio of volume space occupied by bone to that occupied by fins is always greater than 1 to 1, and may be as high as 5, 6 or 7 to 1. Indeed, the theoretically ideal ratio of respective volumes in the interdigitated space is the inverse of the strengths
30 of the two materials, or for bone and implant grade metals, approximately 20 or 25 to 1.

In contrast, bone ingrowth into porous material takes at least several weeks and the bone projections into the pores have a maximum dimension of 0.5 to 1mm



- 29 -

in any direction. The porous material in U.S. Patent 3,855,638 specifies a maximum porosity of 40%. Therefore, where the bone and porous material occupy the same space, the ratio of volume space occupied by bone to that occupied by metal is always less than 1 to 1. The mechanics of the porous metal to ingrown bone is not efficient, because the metal is stronger than the bone by approximately 20 to 1 on a volume basis.

In the preparation of the femur 12 preferably each cavity in the bone is cut slightly smaller than the part of the prosthesis which will fit in the corresponding part of the cavity. Bone will accept the prosthetic elements so driven into undersized cavities, albeit at a great spread of allowable dimensional interference. The soft cancellous bone will easily yield to accept prosthetic intrusion, while the hard cortical bone of the femoral shaft will yield only slightly, and can be split if asked to accept too great an interference fit.

The size relationships of the elements of the prosthesis to the bone of FIG. 4 are very important. Collar 22 preferably has a size and shape to cover the entire area of excised bone in contact with the under-surface of the collar at 24. The envelope of the volume of the fins 26 preferably corresponds closely to the size and shape of the cancellous bone at the proximal end of femur 12. The cross section of the femur in this area is more elliptical than round, having a larger diameter medially to laterally than anteriorly to posteriorly. Accordingly, the envelope of the flutes should be elliptical on the same axes. It is preferred that the flutes fill the cancellous bone space sufficiently that the outer edges of the flutes contact some cortical bone of the wall of the femur,



- 30 -

especially at the anterior, posterior and medial aspects. The distal stem 20 must fit within the shaft of femur 12 so that there is no transverse movement or looseness in any direction. Preferably the stem 16 fits tightly in the canal of the femur as a result of femoral reaming and prosthesis size selection. FIG. 4, however, shows an alternate implantation technique where the distal stem 20 is held securely within the femoral canal by the use of PMMA cement confined to the area 32. As explained above for the inventive construction, forces transferring from the prosthesis 10 to the femur 12 are much smaller at the distal end than at the proximal end of the prosthesis. Under this circumstance, the PMMA cement will provide satisfactory long-term security of fixation of the distal stem 20 within the canal of femur 12. Further, the invention tends to create minimal axial shear and torque loads on cement so used.

FIG. 5 shows a detailed view of the femoral prosthesis 10 where the fins at 28 are designed to be self-broaching so as to cut their own path into the cancellous bone of the proximal femur. FIGS. 4 and 5 are generalized drawings to illustrate the principles of the invention.

Refer to FIGS. 6 through 11 which show alternative preferred embodiments where collar 122 and flutes 126 and 128 are attached to the thin wall conical sleeve 34. In this case, the femoral prosthesis 40 has no collar or fins, but rather has the conical taper 42 which fits within the tapered inner bore 36 of sleeve 34 by the well-known principle of self-locking tapers. In the implanted condition of FIG. 6, the sleeve 34 and the stem of prosthesis 40 are locked together as a single unit and will respond to the applied force system as described above.

- 31 -

This embodiment provides numerous practical advantages. To cover a range of size and shapes of femurs 12, fewer sizes of femoral prostheses 40 are required when compared with the construction of FIG. 5.

5 A large assortment of fluted sleeves 34 is required to permit selection for optimum fit in the proximal femur. The sleeves 34 are much cheaper and smaller than the prostheses 10 or 40, however, and therefore present much less of an inventory problem for the manufacturer

10 and the user. The sleeve 34 may be fabricated from porous metal, or have its outer surfaces coated or treated by any of a number of techniques designed to enhance fixation to bone. The prosthesis 40 becomes an uncompromised structural member, and can be designed

15 and fabricated to that purpose. The procedure for implantation is facilitated for the surgeon, because it can be done in a sequence of simple steps.

To implant the prosthesis embodiment of FIG. 6, the surgeon excises the head and neck of the

20 femur to provide access to the femoral canal. The canal is reamed to a depth and diameter to accept the stem 16 of the prosthesis 40. Reamers are provided which are matched to the lengths and diameters of the several prosthesis stem sizes available. The reamer

25 also removes bone to accommodate the wall thickness of sleeve 34. Generally, the surgeon will select the largest reasonable stem size which will fit within a given femur. An appropriately designed instrument, located in the reamed canal, is used to cut the proximal

30 surface of the femur around the canal at 90° to the centerline of the reamed canal. This surface will then abut accurately with the undersurface of the collar 24 when the fluted collar is driven into position. A multi-fluted broaching tool can be used to prepare a

- 32 -

bed for the fluted sleeve 34, where each groove cut in the femoral bone will be slightly smaller than the corresponding flute which will fit in the groove. Of course, the broached grooves must be in correct angular orientation for the construction of FIG. 6 where anti-rotational lugs 46 engage the shoulder 48 of prosthesis 40. Anti-rotation lugs 46 may be furnished as an assurance to the surgeon, but they are not necessary to prevent rotation of stem 16 within sleeve 34 when the stem 16 is solidly seated within the taper 36 of sleeve 34.

FIG. 8 shows an embodiment of sleeve 34 with self-broaching flutes 128 and a short internal thread 38 at the small end of the tapered bore 36. Each flute or rib 128 is shown to extend the entire length of sleeve 34 and stepped teeth 35 are shown as a means of making the flute self-broaching. Alternatively, the broaching teeth on each longitudinal flute can be formed by cuts or notches 29 shown in FIG. 14 which interrupt the lengthwise continuity of the flute 128. The individual flute segments 31 lie in lengthwise alignment as shown at 33 in FIG. 9. The effective length of an individual flute or rib 128 is specified to be the total length of a series of segments 31 which are in longitudinal alignment, and which segments follow one another into the same space in the bone as the sleeve is being implanted in the bone. This sleeve may conveniently be used with the impact instrument 60 of FIG. 12 for implantation into the proximal femur when the femur has not previously been broached with a fluted broach. Sleeve 34 fits on taper 62 of instrument 60, with collar 22 engaging shoulder 64 and thread 38 engaging thread 66. Stem 68 aligns instrument 60 in the reamed femoral canal. Slide hammer 70 is then reciprocated to

- 33 -

drive the fluted sleeve 34 into the proximal femur. Sleeve 34 is available in a series of increasing sizes of envelope of the flutes 28 for each given tapered bore size 36. The surgeon first implants the sleeve
5 with the smallest envelope. The energy required to seat the sleeve gives an indication of the security of seating. If the tightness of fit is judged inadequate, the sleeve is removed by operating the slide hammer 70 in the outward direction. Threads 68 engaged in threads
10 38 permit the sleeve to be so extracted. The next larger fluted sleeve is implanted, and so on until the surgeon is satisfied that a sleeve 34 is securely fixed in the proximal femur 12. It is recommended that at least four sizes of sleeve be furnished for each stem
15 size, and that the increase in sleeve fin envelope diameter be approximately 1.5mm per size.

When a sleeve 34 has been securely seated in the proximal femur, the surgeon selects a femoral prosthesis 40 of correct taper diameter 42 and of
20 diameter of distal stem 50 to fit securely with the reamed femoral canal. The distal end of stem 16 of FIGS. 6 and 10 is shown with longitudinal flats 50. These flats are designed to increase the latitude of diametral fit of the stem in the bone for which there
25 will be no lateral motion between the stem and the bone, and to reduce the hazard of splitting the femoral shaft by an overly tight fit. The distal end 50 of the stem 16 is made with a smooth surface and is neither intended to transmit axial shear load from the stem to
30 the bone, nor intended to transmit torque from the stem to the bone.

Should there be any reason for the distal stem 50 to not engage securely with the femoral canal, the surgeon may elect to place PMMA cement in the canal



- 34 -

in the area indicated at 32 in FIG. 4 prior to the final insertion of the femoral prosthesis 40, and the prosthesis is driven solidly into engagement with the internal taper 36 of sleeve 34. Again, it must be emphasized that cement is not used in the cancellous bone of the proximal femur. Note that in the sequence just described, the finned sleeve is fully implanted before cement would be delivered to the femoral canal for anchoring the distal stem. This sequence prevents cement from entering the interface between the fins and the cancellous bone.

The femoral prosthesis 40 implanted according to the above description is fixed to the femur with adequate strength to permit early physical therapy and rehabilitation of the patient. The pattern of load transfer to the femur creates stresses which favor the retention of and development of sound bone in proximal femur, and increased activity by the patient will tend to improve the bone structure in accordance with the above.

With regard to the aspect of the present invention relating to the thin walled truncated conical sleeve with a smooth inner surface, there is shown in FIG. 15 the proximal end of a human femur 110. Phantom line 112 shows the normal head of the femur which has been excised for implantation of the prosthesis 120. The hard outer shell 112 of the femur is known as dense or cortical bone, and the less dense inner bone 114 is known as spongy or cancellous bone.

Femoral stem prosthesis 120 is shown implanted in femur 110 with threaded sleeve 140 being used to provide initial high force resisting fixation; force C is axial compression and force B_1 is the bending force due to the patient's weight force W being offset from the femoral shaft.

- 35 -

The femoral prosthesis 120 implanted in combination with sleeve 140 may be said to be one half of a total hip joint prosthesis. The sleeve 182 and cup 184 shown in FIG. 22 are the other half of a total hip joint prosthesis. Note that sleeves 140 and 182 do not perform any of the motion functions of the joint, while stem 120 and cup 184 each perform part of the motion of the joint at the contact area between sphere 129 and cup 184.

Stem prosthesis 120 and sleeve 140 are mechanically locked by mating tapers 122. Mating metallic cone tapers are self locking when the included angle of taper is less than approximately 15° , depending on the particular metals, finish and coefficient of friction. The preferred taper is approximately 6° included angle, or 3° taper per side. It is preferable to make both sleeve 140 and stem 120 of titanium alloy, which metal against itself has a high coefficient of friction and galling tendency, further enhancing the locking ability of taper 122. The stem 120 is seated firmly in sleeve 140 by means of mallet blows to surface 128, or preferably to an intermediate protective device used between the mallet and the prosthesis.

FIG. 18 shows reamer 130 which is used to prepare the canal of femur 110 for implantation of stem prosthesis 120 and sleeve 140. Reamer 130 has various diameters and tapers as follows. Portion 132 of reamer 130 is tapered and sized to provide optimum function of the external self-tapping threads 144 of sleeve 140. Portion 134 is sized to provide a press fit of portion 124 of stem 120 of 0.5 mm. or more. This portion is preferably tapered approximately 2° included angle for both the reamer 130 and the stem 120. Portion 136 is sized to provide bone which will be broached by the



- 36 -

axial self-broaching flutes on portion 126 of stem 120. This portion is preferred to be cylindrical or non-tapered on both stem 120 and reamer 130. The secure fixation of portion 126 of stem 120 in femur 110 is
5 required to resist the second bending force B_2 . Firm fixation of stem portion 126 is also importantly required to resist torsion forces on stem 120, thereby relieving sleeve 140 of the need to resist torsion forces during the early course of bone healing by redensifying and
10 reshaping to accept the new loading pattern.

Thin walled threaded sleeve 140 is shown in detail in FIG. 16 in partial section. Bore 142 mates with taper 122 of stem 120. Screw thread 144 is preferably a multi-start (2-6) thread of 1 to 3 mm. pitch
15 and 2 to 10 mm. lead. The taper, plus the high lead, allows the sleeve to be screwed home in relatively few turns, with the sleeve becoming ever tighter with additional turning. The outside diameter of sleeve 140 can have one or more tapers, and can taper differently from
20 the bore 142. Indeed, for a given bore 142, a selection of different thread O.D.'s and tapers should be made available to the surgeon so threads 144 can be chosen to suit the density and thickness of a particular patient's cancellous bone 114, much as a wood screw
25 which does not hold well can be replaced by a screw of larger diameter. Thread depth can also vary.

In self-tapping threaded sleeve 140, multiple cutting flutes, as at 146, may be provided; and multiple slots 148 are provided to permit driving the threaded
30 sleeve 140 into position. In order that insertion of sleeve 140 is made in proper geometrical alignment with the cavity prepared by reamer 130, insertion tool 150 is provided as shown in FIG. 19. Sleeve 140 is placed on tool 150 where bore 142 is a free fit on taper 152,

- 37 -

and slots 148 of the sleeve are engaged by pins 158. By using tool 150 to drive sleeve 140 during insertion, axial alignment is maintained between tapered bore 142 of the sleeve and prepared canal diameter 116 in the femur. This alignment prevents inducing unwanted bending stresses in the system when stem 120 is implanted, as would happen if sleeve 140 were not aligned with the prepared canal.

After sleeve 140 has been implanted, stem 120 is inserted into the prepared canal of femur 110 through bore 142. The head 129 of the femoral prosthesis 120 must be positioned in correct rotary angular location relative to femur 110 before the self-broaching longitudinal flutes 126 penetrate the prepared canal 116. Surface 128 is provided for contact by an appropriate instrument for driving prosthesis 120 into final seated position.

Femoral prosthesis 120 is furnished in a selection of sizes, and a size must be chosen so that fluted portion 126 engages at least some of the cortical bone 123 of femur 110. Of course, each different size of prosthesis 120 requires a different set of mating sleeves 140, and a different reamer 130.

The advantages of the invention would not be attained by putting the external thread 144 of sleeve 140 directly on tapered portion 122 of prosthesis stem 120. The first reason is that a threaded prosthetic stem 120 could not be screwed home in the femur as shown in FIG. 15. The neck 127 of the prosthesis would interfere with the greater trochanter 118 of the femur 110 preventing installation to the desired geometry as shown. The second reason is that the torque required for screwing home during installation must be within the capability of the surgeon to apply, and is estimated



- 38 -

to be approximately 125 lbs feet of torque. The magnitude of torque applied to the prosthetic stem by even limited patient activity is estimated to be approximately the same. It is also apparent that were
5 a stem 120 with integral threads at 122 to be used, there could not be at the same time axial broaching flutes as at 126. Therefore, were the only torque resistance to rotation of prosthesis 120 to be afforded by threads as proposed immediately above, the prosthesis
10 would be inadequately fastened to be sure it would not move relative to the bone were the patient to initiate even limited use of the joint within a few days post operatively. Thirdly, a threaded outside diameter on the prosthesis stem 120 would significantly reduce the
15 fatigue bending strength of the stem.

FIGS. 20 and 21 show the implantation of an artificial knee joint using the inventive externally threaded thin wall sleeve. The femoral prosthesis 162 has a stem 164 which locks within the mating taper of
20 externally threaded sleeve 166 shown partially in section. The mechanics of installation are identical with those described for installing the femoral hip prosthesis and related sleeve shown in FIGS. 15 through 19. The necessity for being readily able to achieve
25 correct angular position of femoral prosthesis 162 is apparent in this application because the condylar portions of the prosthesis are positioned within a cutout in the distal condylar portion of the natural femur. It would not be possible to screw home such a
30 femoral prosthesis were the screw threads on the stem of the prosthesis.

On the tibial side of the knee joint of FIG. 20, an externally threaded thin wall sleeve 170 is anchored by being screwed into the prepared tibial



- 39 -

canal. In this instance, however, the part within the threaded sleeve is a thin walled bearing 172 which has the integral flange 174. This bearing 172, with its integral flange 174, is preferably made from ultra
5 high molecular weight polyethylene plastic and bearing 172 and integral flange 174 serve as an axial and thrust bearing for and receives metal tibial stem prosthesis 176. Tibial stem prosthesis 176 is free to rotate within bearing 172 and also free to distract
10 from thrust bearing flange 174 as described in U.S. Patent No. 4,219,893 to Noiles.

FIGS. 22 and 23 show a tapered externally threaded sleeve 182 and a bearing cup 184 received within sleeve 182 forming the acetabular prosthesis 180
15 of an artificial hip joint. The multi-start thread 181 is interrupted by multiple flutes 183 which enhance the self-tapping ability of the threads. Multiple slots 185 are provided to engage a driving tool during insertion. A properly proportioned reamer, not shown, is
20 provided to prepare the bony acetabular cavity in the pelvis 186 for implantation of the sleeve 182.

After sleeve 182 has been implanted, bearing 184 which has screw threads at 188 is assembled into sleeve 182 by engagement with screw threads 187 in
25 sleeve 182. Bearing 184 may be of metal or plastic. It may encompass more than 180° of the sphere 129 of femoral prosthesis 120 of FIG. 17. Such a construction is described in U.S. Patent No. 3,848,272, now U.S. Reissue Patent No. Re. 28,895 issued to Noiles. Or the
30 bearing 184 may encompass 180° or less of the sphere 129, in which case it may have been assembled with sleeve 182 prior to surgery.

An alternate advantageous embodiment is shown in FIG. 24, comprising a tapered externally threaded

- 40 -

sleeve 192 into which is received acetabular bearing 194 by means of a threaded attachment like that shown in FIG. 22. A part of the acetabular bearing 194 and sleeve 192 assembly has been cut obliquely at 191, at an angle of from 10-30°, to allow additional range of motion of femoral prosthesis neck 127 in the segment of the cut 191. The cutout portion of cut 191 extends for less than 180° of the threaded periphery of bearing 194. Orienting the oblique cut at 191, anteriorly permits additional motion to the anterior of the body, and indeed more closely mimics the natural anatomy. Because the cut 191 is desired to have a specific angular orientation when the threads 193 are firmly seated in the bone, the thread taper angle, lead, and depth must permit knowing in advance very closely how much rotation is required to achieve full depth thread engagement from the starting condition where the crowns of the threads first contact the prepared cavity. For instance, the rotation to achieve tightening can be made to be very close to 360° if the depth of the thread divided by the lead equals the tangent of the angle of taper of one side.

FIG. 25 shows radial flutes 195 formed in the surface 197 of sleeve 192 which have two functions. One, the reamer used to prepare the cavity for insertion of sleeve 192 has a convex surface to cut the bottom of the acetabular cavity with a concavity at 197 and, therefore, to leave bony material in place in the area 198 which interferes with the full depth seating of sleeve 192. Flutes 195 can be forced into this interfering bone to provide gradually increasing resistance to the final seating of sleeve 192 when threads 193 are in approximately full engagement with bone. This feature allows a small angular range of rotation at

- 41 -

final seating to assist locating cutout 191 in the desired position. Second, the bone chips cut into the flutes 195 will develop with new bone generation to improve the fixation of sleeve 192.

5 With reference generally to FIGS. 26-32, and FIG. 26 in particular, there is shown the two-part support for a dental prosthesis 210 implanted in jawbone 212 between two natural teeth 214. The drawings, except where noted, omit showing the soft gum or gingival
10 tissues.

FIG. 27 shows, in section, the hollow tubular member 216 which has external thread 218 at one end, the smooth exterior at the closed end 220, and the self-locking internal taper 222. Thread 218 and the smooth
15 exterior of closed end 220 each occupy about half the length of hollow tubular member 216. Member 216 also has a hexagonal or splined socket at 224 with which a suitable inserting tool engages for screwing member 216 into the prepared cavity in jawbone 212.

20 The prepared cavity in jawbone 212 accepts member 216 so that the smooth closed end 220 is a tight fit. That is, the diameter of the reamed hole is somewhat smaller than the diameter of smooth portion 220. The nature of the bone within jawbone 212 yields
25 to accept portion 220 in the manner in which a piece of wood accepts a nail driven into an undersized pilot hole. The prepared bone cavity is reamed to approximately the root diameter of screw thread 218 of member 216 to the depth that the screw thread 218 penetrates
30 the jawbone. The hole in the jawbone may be tapped prior to implanting member 216, but preferably thread 218 is of self-tapping design. When such a self-tapping thread is inserted once and left in position, the bone chips created during the insertion lie in the interface

- 42 -

between the threads and the bone, filling small spaces which exist in the bone, and serve as nuclei for the growth of new bone cells which more firmly anchor the implant.

5 FIG. 27 shows the second member, pin 230, positioned within tubular member 216. Pin 230 has three zones, each with a different function. The zone at 232 is a male self-locking taper which mates with the corresponding female self-locking taper 222 within
10 member 216. The central zone 234 is generally cylindrical and smooth and is that portion which passes through the gum tissue which covers jawbone 212. The third zone 236 serves as the fastening area for the prosthetic bridge, tooth, or appliance. The zone 236
15 is shown as a male self locking taper, but could have any suitable configuration such as a male or female screw thread, or a grooved configuration as shown in FIG. 32 where a single artificial tooth is fused or cemented directly to pin 230.

20 The structure of FIG. 26 can be created at the time of implantation and the pin 230 used for limited function while the bone and gum tissue heal around the implant because the implanted system has sufficient mechanical strength to prevent unwanted
25 motion between the implant and the bone. However, some practitioners currently favor a more conservative postoperative course using the means shown in FIG. 28.

In FIG. 28, tubular member 216 is provided with a female screw thread 226 formed in a recess at
30 end of socket 224 in the closed end. A temporary screw plug 227 is inserted to seal the opening in tubular member 216, after which gum tissue 228 is closed over the implant by suture 229. This condition is maintained for the desired time, perhaps 2 to 4 months, during



- 43 -

which time the bone and gum tissue recover from the trauma of surgery and the bony anchorage of member 216 becomes even more secure. After this time of healing, the gum tissue is opened, plug 227 removed, and pin 230
5 is securely inserted.

When the implant is functional, loads are transmitted to the bone by the implant in a manner different from that done by the natural tooth. Therefore, the jaw bone will remodel its shape and density
10 to accommodate the new load distribution pattern. The desirable load transmission pattern of the invention will be discussed with reference to FIG. 32. The total load on the artificial tooth 280 and the implant 210 is shown as F_T . The largest component of F_T is known to
15 be downward compression force F_C . Compression force F_C is transmitted from the implant 210 to the bone 212 by shear and bending of the bone adjacent screw threads 218, by shear at the interface between the bone and smooth surface 220, and by compression of the bone
20 beneath closed end 221. The greatest area of contact between implant 210 and bone 212 is at screw thread 218. Therefore, the greatest amount of load will be transmitted to the bone at the screw thread. This load transfer will cause an increase in the amount and
25 density of bone adjacent the screw threads. This occurrence is most desirable because recession of bone at this alveolar ridge area has been an ever present problem inhibiting long-term success in most dental implants to date. Design proportions and postoperative
30 activity must be controlled to keep the stress on the bone within physiological limits, because excessive stress is also reported to cause destruction of bone. However, with generous surface area of the threads and gradually increasing functional loads, the jawbone

- 44 -

will remodel itself to support the prosthesis in a favorable manner.

With reference to FIG. 32, the benefit of increased implant to bone interface area adjacent the alveolar ridge is vividly illustrated with respect to the bending load component F_B applied to the artificial tooth 280. Bending component force F_B will cause two reactive bending forces to occur between the bone and the implant, shown at R_T operating on the threaded area 218 of implant 210 and R_S operating on the smooth closed end portion 220 of implant 210. Depending on geometry, R_S may be approximately equal to F_B . Force R_T must equal F_B plus R_S , because the summation of horizontal forces must be equal to zero. From this we see that R_T must be approximately equal to twice R_S . Accordingly, the interface between implant and bone should be larger at R_T than it is at R_S . The inventive construction satisfies this requirement.

An alternate embodiment is shown in FIG. 29, comprising a tapered external threaded sleeve 238 into which is received pin 250. The four functional zones of pin 250 are the smooth extended end portion 252 which fits securely in a prepared cavity in bone 212, the self-locking male taper 254 which fits within sleeve 238, the generally smooth cylinder 256 which penetrates the gum tissue, and the bridge, tooth or appliance mounting portion 258, which is again shown as a male self locking taper. This embodiment has the advantage that several external size variations of sleeves 238 can be combined with several length variations of pins 250 to provide a greater number of overall size combinations with fewer parts than can the construction of FIG. 27. This makes for more economy in manufacturing and in sales and hospital inventory



- 45 -

storage. To provide for closed early healing, a temporary stub pin having only zones 252 and 254 can be implanted during the time the gum tissue remains closed over the implant. Alternatively, only sleeve 238 can
5 be implanted initially with a temporary plug of zone 254 shape in place while the implant is covered. In this case, the cavity for zone 252 of pin 250 would be prepared after the time of initial bone healing around sleeve 238. Sleeve 238 can be made with fluted or hex
10 splines 239 in the small end of its bore to provide means for driving into place, and for removal if necessary.

A second alternative embodiment of the tubular member is shown as member 260 in FIGS. 30 and 31. The
15 principle of increased bone to implant interface area adjacent to the alveolar ridge is provided by the multiple longitudinal fins 262. This embodiment permits a somewhat larger pin to be used because the walls of tubular member 260 can be thinner at the buccal and lingual regions 266
20 due to the absence of external threads. In this case, the compression load component F_C is transmitted to the bone adjoining fins 262 more by shear than by compression or bending, and providing a porous or textured surface on the fins is advantageous. The prepared bony cavity
25 for this implant is sized to accept the tapered portion 270 and the extended portion 264 with a secure tight fit, as described above, and the fins are preferably shaped to broach or cut their own path into the bone 212. Again
30 bone chips created by the broaching act as nuclei for new bone growth. Thread 268 is provided for attachment of an inserting tool for use during the implant procedure. It permits removal of one size of tubular member 260 when the clinician believes that use of a larger size would be desirable.



- 46 -

Smooth cylinder 220 (FIG. 27), smooth cylinder 252 (FIG. 29) or smooth cylinder 264 (FIG. 30) may be substituted by a cruciform shape (four flutes) or any irregular or other regular cross section (including a varying cross section). The important feature is that the surface area of the upper half of member 216 (FIG. 27), and its corresponding part in the other figures, is at least twice the surface area as the lower half.

Numerous modification and variations of the present invention are possible in the light of the above teachings. For instance, use of a single thread is within the contemplation of the invention which has characteristics which fall within the parameters given for multi-start threads. Also, the threads on the outer surface of the thin wall sleeve may be of a porous metal or ceramic or may be treated with a biologically active coating.

In addition, with regard to the dental implant, certain porous coatings could be applied to the implanted surface adjacent the alveolar ridge, while the deeper implanted surface could be uncoated and smooth. Or the closed end of the pin may have a cruciform cross section to increase its flexibility and thereby perhaps improve the force transfer pattern between prosthesis and bone. Also the outer surface of the implant as illustrated may be a porous metal, ceramic, plastic or carbon or may be treated with a biologically active coating.

The invention is applicable for other implants in the human or animal skeleton, as for instance for artificial joints for most joints of the body, i.e., the ankle, shoulder, elbow, wrist and finger. It is therefore understood that, within the scope of the appended claims, the invention may be practiced otherwise than as specifically described.

- 47 -

Claims

1. A prosthesis for mounting in a bone comprising a sleeve intended for mounting in a cavity defined in the bone to provide initial intimate load bearing prosthesis-to-bone interface and a member received within the sleeve, said member and the internal surface of said sleeve defining mutually coacting means to fix said member in said sleeve, said sleeve defining an external geometric pattern of projections which engage the bone when implanted in the bone.

2. The prosthesis of claim 1 wherein said projections of the sleeve are self-tapping screw threads.

3. The prosthesis of claim 2 wherein the threads are multi-start.

4. The prosthesis of claim 2 wherein the pitch of the threads is about five times the width of a thread.

5. The prosthesis of claim 1 wherein the sleeve is conical.

6. The prosthesis of claim 1 wherein the sleeve defines means at one end to facilitate engagement and turning.

7. The prosthesis of claim 1 wherein the mutually coacting means is in the form of mating self-locking tapers.

8. The prosthesis of claim 1 wherein the mutually coacting means is in the form of threads.

9. The sleeve of claim 1 for use in an artificial prosthetic joint comprising an externally threaded sleeve for screwing into a cavity defined in a bone to provide initial intimate load bearing prosthesis-to-bone interface and having its internal surface so constructed and arranged that the sleeve is capable of



- 48 -

receiving and locking one component of the artificial prosthetic joint.

10. The sleeve of claim 9 wherein the internal surface of the sleeve is one portion of mating self-
5 locking tapers the other portion of which is defined by the one component.

11. The sleeve of claim 9 wherein the internal surface is defined with threads to coact with threads defined on the one component.

10 12. A two-part system comprising one side of an artificial prosthetic joint in which:

an externally threaded first part screws into the bone to provide initial intimate load bearing prosthesis-to-bone interface and the first part performs
15 none of the motion function of the joint,

and a second part which performs at least part of the motion function of the joint,

and the second part received by and locked to the first part.

20 13. A joint prosthesis component means for fixation to bone, comprising:

first means defining a joint motion surface;
a stem attached to said first means defining a joint motion surface for extending into the central
25 canal of the bone into which the component means is to be fixed;

that part of the prosthesis component means which is intended to be located within the bone at the end of the bone near the joint motion surface defining
30 an external geometric pattern of elongated projections which engage with the bone when implanted in the bone;
and

the effective length of said external geometric pattern of elongated projections is less than one half



- 49 -

of that portion of the prosthesis component means which is intended to be implanted within the bone.

14. A joint prosthesis component means according to claim 13 wherein a collar is defined at
5 the end of the elongated projections near the joint motion surface, said collar being of a shape and size intending to cover the end portion of the bone contacted by the component means.

15 10 15 16. A joint prosthesis component means according to claim 13 wherein said elongated projections have a thickness of from about 0.5mm to about 2.0mm, a height of at least about 0.7mm, a spacing of from about 1mm to about 4mm and an effective length at least ten times their thickness.

15 20 16. A joint prosthesis component means according to claim 13 wherein said joint prosthesis component means includes a first part including the joint motion surface and the stem and a second part in the form of a sleeve including the elongated projections,
20 said parts defining mutually coacting self-locking tapers.

25 17. A bone implant support means for a dental prosthesis characterized in that a first portion of the implant support means intended to be implanted
25 in bone and lie nearest the alveolar ridge has an external surface which substantially increases the interface contact area with bone over that which pertains for a smooth surface, and a second portion of the implant support means intended to be implanted in bone
30 and lie furthest from the alveolar ridge has a substantially uniform cross section.

35 18. A bone implant support means according to claim 17 wherein the first portion constitutes not more than half the depth of the portion intended to be implanted in bone.



- 50 -

19. A bone implant support means according to claim 17 wherein the external surface area of the first portion is approximately twice that of the external surface area of the second portion.

5 20. A bone implant support means according to claim 17 wherein the external surface of the first portion is defined by self tapping thread means.

10 21. A bone implant support means according to claim 17 wherein the external surface of the first portion is defined by self broaching means.

22. A bone implant support means according to claim 17 wherein the external surface of the second portion is defined by a cylinder.

15 23. A bone implant support means according to claim 17 wherein the external surface of the second portion is defined by a smooth cylinder.

20 24. A bone implant support means according to claim 17 wherein the external surface of the second portion is defined by a geometry of uniform cross section.

25. A bone implant support means according to claim 24 wherein the geometry defines a cruciform.

25 26. A bone implant support means according to claim 17 wherein the first portion is the open end portion of a hollow cylinder open at one end and closed at the other and the second portion is the closed end portion.

30 27. A bone implant support means according to claim 17 wherein the first portion is a sleeve and the second portion is pin received through said sleeve.

28. A bone implant support means according to claim 26 further including a pin received in the hollow cylinder and projecting therefrom.



- 51 -

29. A bone implant support means according to claim 28 wherein the hollow cylinder and pin define mutually coacting self-locking tapers.

5 30. A bone implant support means according to claim 28 wherein a first projecting portion of the pin adjacent the hollow cylinder has a smooth cylindrical surface.

10 31. A bone implant support means according to claim 30 wherein a second projecting portion of the pin remote from the hollow cylinder defines a surface means to facilitate mounting of a dental appliance.

32. A bone implant support means according to claim 31 wherein the second projecting portion defines a male cone of a self-locking taper.

15 33. A bone implant support means according to claim 32 further including a dental appliance defining a female self-locking taper mated with said male cone.

20 34. A bone implant support means according to claim 27 wherein said pin projects out of said sleeve and serves as a mount for a dental appliance.

35. A bone implant support means according to claim 27 wherein said pin and sleeve define mutually coacting self-locking tapers.

25 36. The bone implant of claim 17 further comprising a third portion projecting from said first portion and a dental appliance mounted on said third portion.

30 37. A component for use in a prosthetic joint comprising hollow tubular means closed at one end and characterized by the portion thereof adjacent the open end having external features which increase its surface area to at least twice the surface area of the portion adjacent the closed end and the inner surface of said portion adjacent the open end defining a female part of

- 52 -

self-locking taper; and elongated pin means characterized by a first section adjacent one end defining a male cone of self-locking taper to be received in said female part and to coact therewith and a second section adjacent the other end to project from the open end of said hollow tubular means and serve as a support for a joint motion surface.

38. A method for fixation of a joint prosthesis component means to a bone comprising the steps of:

preparing the central canal of a bone forming part of a body joint at the end thereof near the body joint to receive a stem of a joint prosthesis component means having a joint motion surface, a stem to be received in the central canal of the bone, and an external geometric pattern of effectively elongated projections;

cutting a geometric pattern of elongated cavities in the central canal of the bone at said end near the body joint, said cavities being characterized by an inverse related geometry to the external geometric pattern of effectively elongated projections to the prosthesis component means to enable interdigitation of the projections with the bone with zero clearance between the projections and cavities; and

fixing the prosthesis component means to said bone by inserting the stem thereof into the prepared canal and forcing the projections into the cavities in engagement with the bone with sufficient security to have the prosthesis component means implanted in the bone.

39. The method according to claim 38 wherein the preparation of the central canal includes the step of excising a portion of the end of the bone transversely



- 53 -

to the canal axis and providing a collar at the end of the elongated projections near the joint motion surface which contacts the excised end of the bone and which is shaped and sized to substantially cover same.

5 40. The method according to claim 38 wherein the effective length of said external geometric pattern of effectively elongated projections is less than one half of that portion of the prosthesis component means which is implanted within the bone.

10 41. The method according to claim 38 including the further step of cementing the stem in the canal at its end remote from the joint motion surface.

 42. A method for fixation of a joint prosthesis component to a bone comprising the steps of:
15 preparing the central canal of a bone, forming part of a body joint at the end thereof near the body joint to receive a joint prosthesis component in the form of a sleeve having an external geometric pattern of effectively elongated projections;

20 cutting a geometric pattern of elongated cavities in the central canal of the bone at said end, said cavities being characterized by an inverse related geometry to the external geometric pattern of effectively elongated projections to enable interdigitation
25 of the projections with the bone with zero clearance between the projections and the cavities; and

 fixing the joint prosthesis component to said bone by inserting the sleeve into the prepared canal and forcing the projections into the cavities in engagement with the bone with sufficient security for the
30 sleeve to be implanted in the bone.

 43. The method of claim 42 further comprising excising a portion of the bone at said end transversely to the axis of the central canal, and wherein said



- 54 -

preparing step includes providing said sleeve with a collar at an end and said collar contacts the excised area of the bone.

5 44. The method of claim 42 wherein another joint prosthesis component in the form of a joint motion surface with attached stem is coupled to said first mentioned joint prosthesis component by inserting the stem into the prepared central canal through the sleeve.

10 45. The method of claim 44 wherein the end of the stem remote from the joint motion surface is cemented in the central canal.

 46. A method for implanting means for a dental prosthesis comprising the steps of:

15 (1) preparing a portion of a jawbone by creating a cavity to accept a support means including a hollow cylinder having surface features adjacent one end that substantially increase the interface contact area with bone over that which pertains for a smooth
20 surface;

 (2) inserting said support means into said prepared cavity with the surface features lying nearest the alveolar ridge;

25 (3) maintaining the cavity by sealing the opening of the hollow cylinder to allow the bone and gum tissue to heal around the hollow cylinder; and

 (4) subsequently to healing, inserting a pin into said hollow cylinder to project therefrom through the gum tissue and beyond to serve as a mount for a
30 dental appliance, said hollow cylinder and pin being mated by self locking tapers.

 47. A tool for implanting a joint prosthesis component comprising:

 a first shaft;



- 55 -

a second shaft;

a tapered section interconnecting the two shafts with the first shaft having one end joined to the smaller diameter end of the tapered section and the
5 second shaft having one end joined to the larger diameter end of the tapered section;

the one end of the first shaft defining threads;

the larger diameter end of the tapered section
10 defining a collar;

a handle located on the other end of the second shaft;

a stop fixed to the second shaft adjacent said one end; and

15 a hammer slidably received on the second shaft between the handle and the stop.



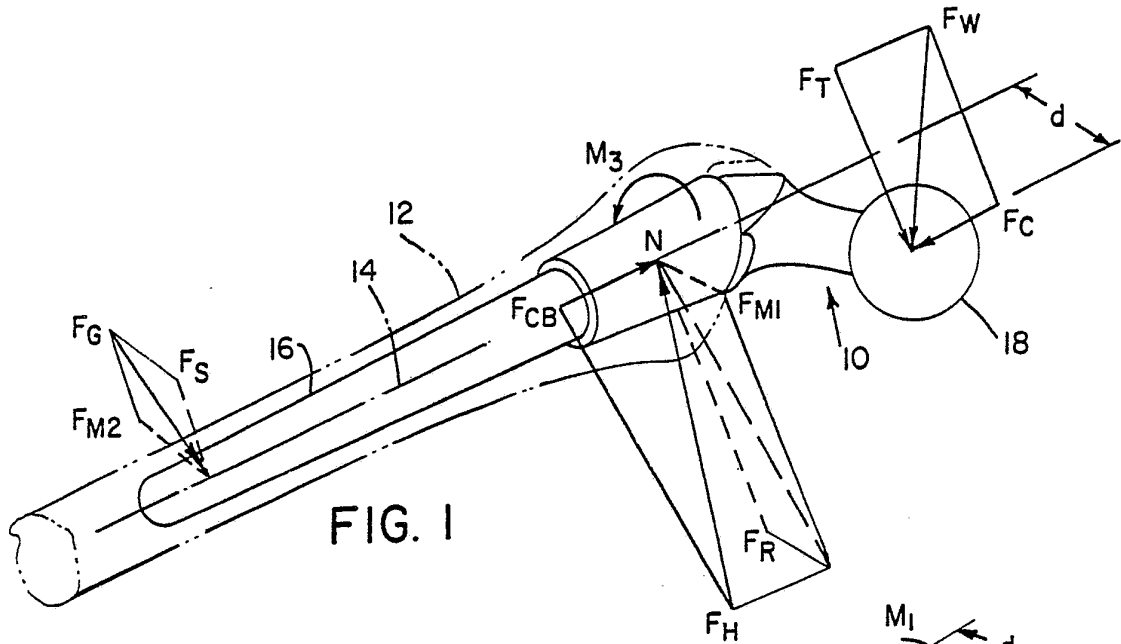

FIG. 1

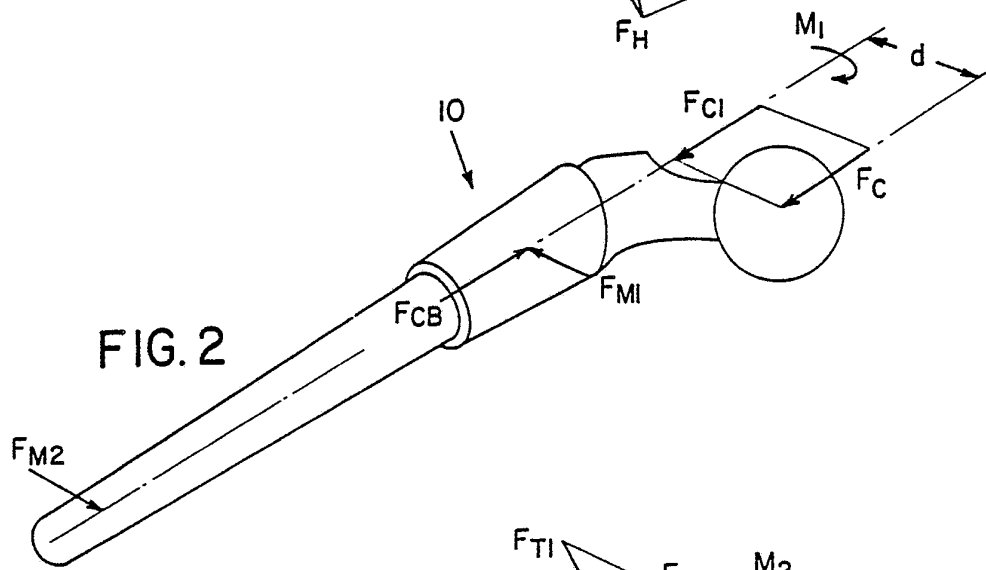

FIG. 2

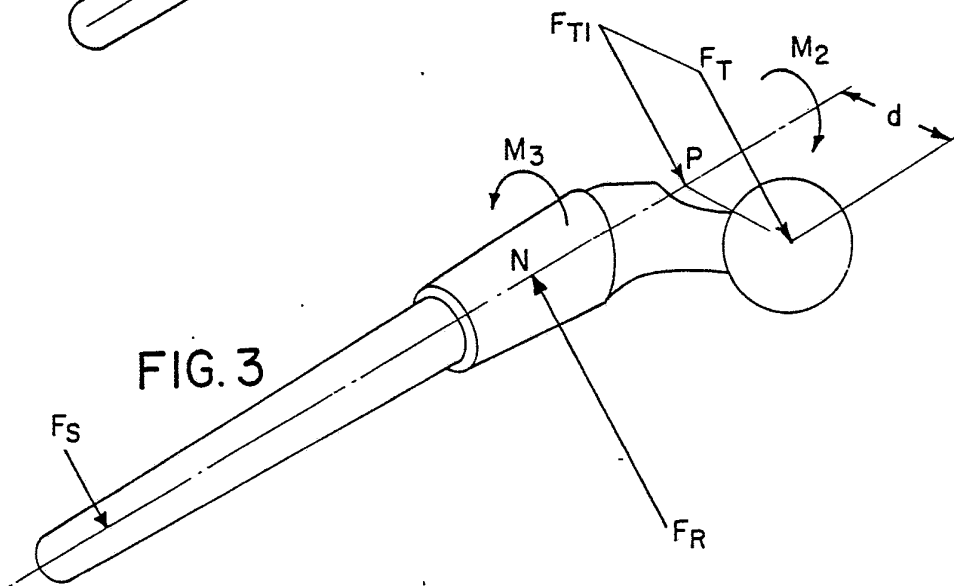

FIG. 3

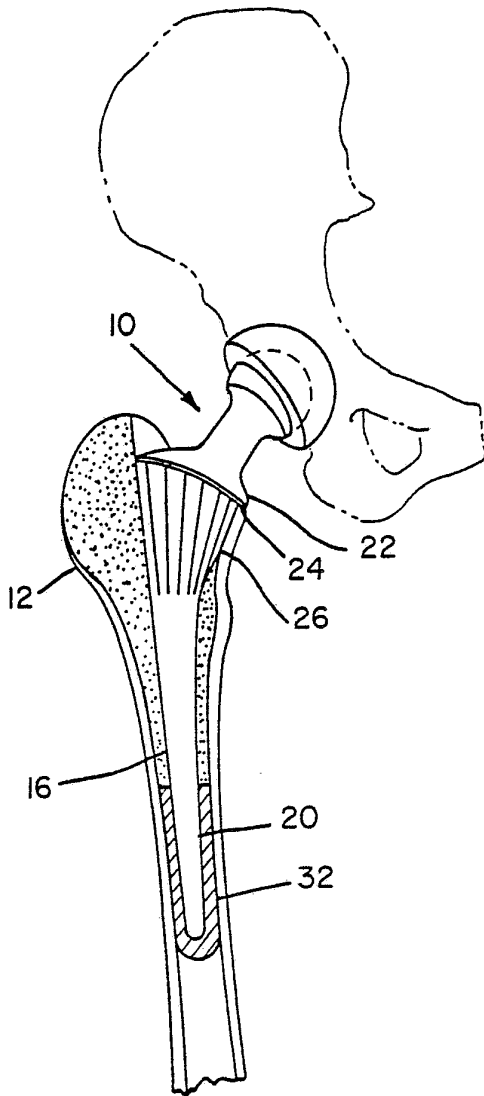

FIG. 4

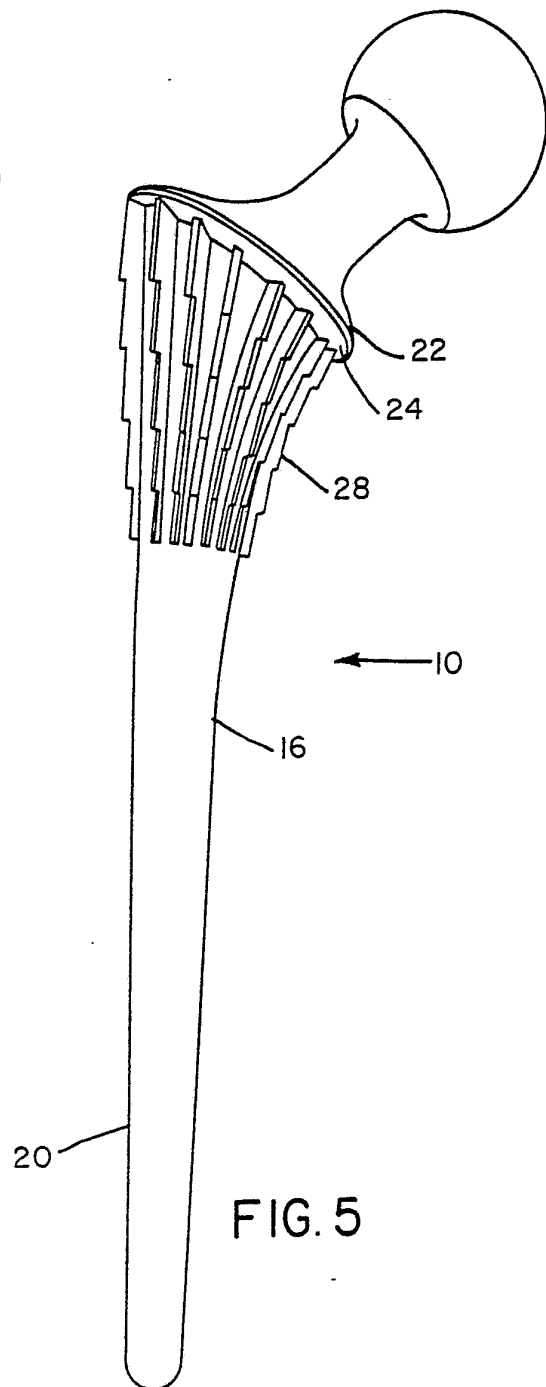

FIG. 5

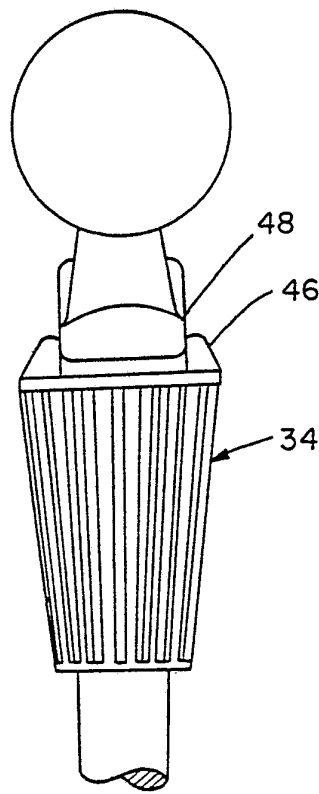
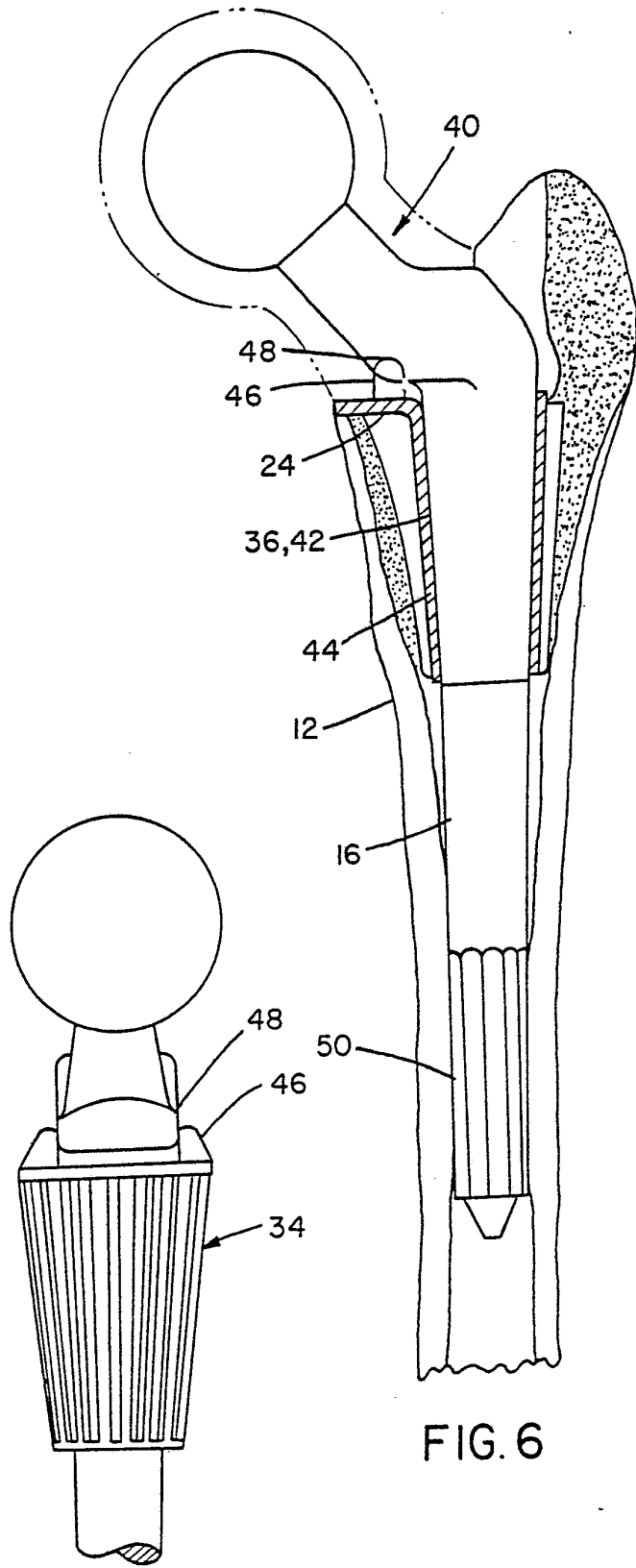
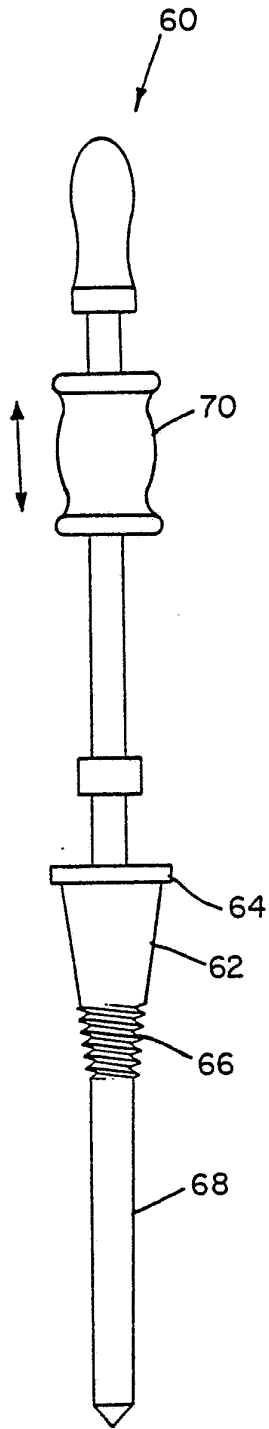

FIG. 7

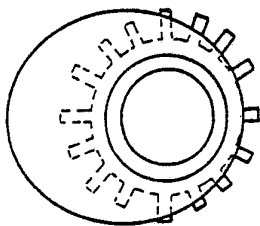

FIG. 9

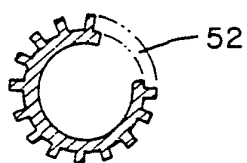
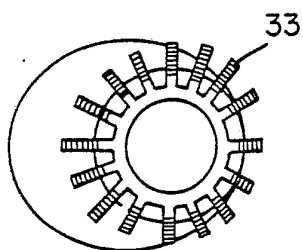

FIG. 13

FIG. 8

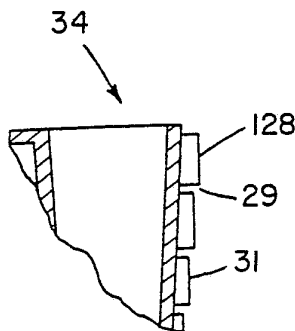
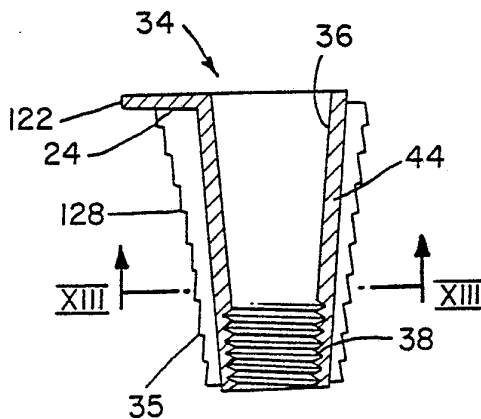

FIG. 14

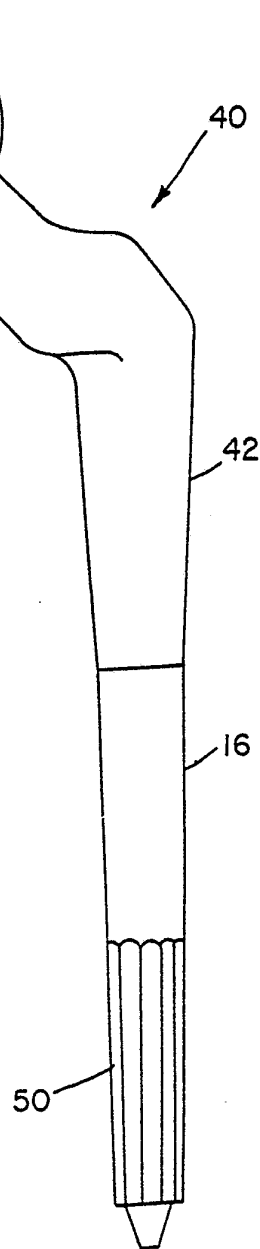

FIG. 10

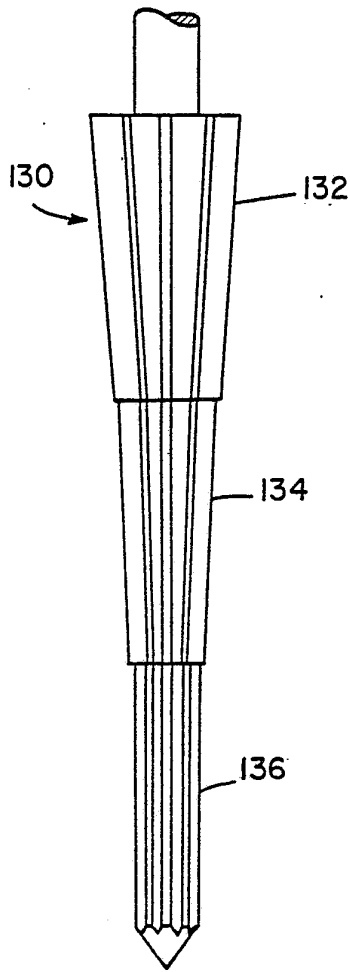

FIG. 18

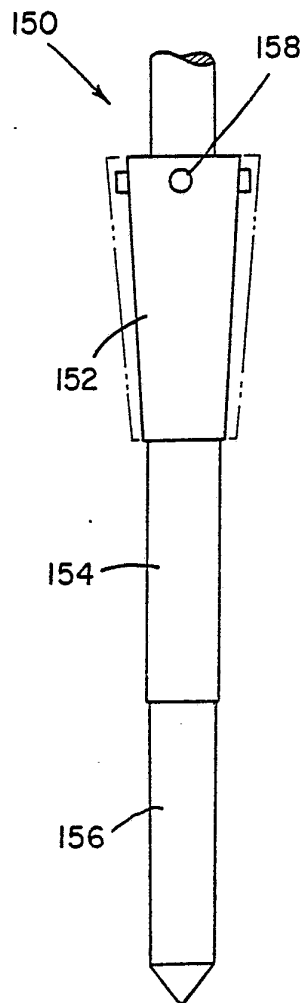

FIG. 19

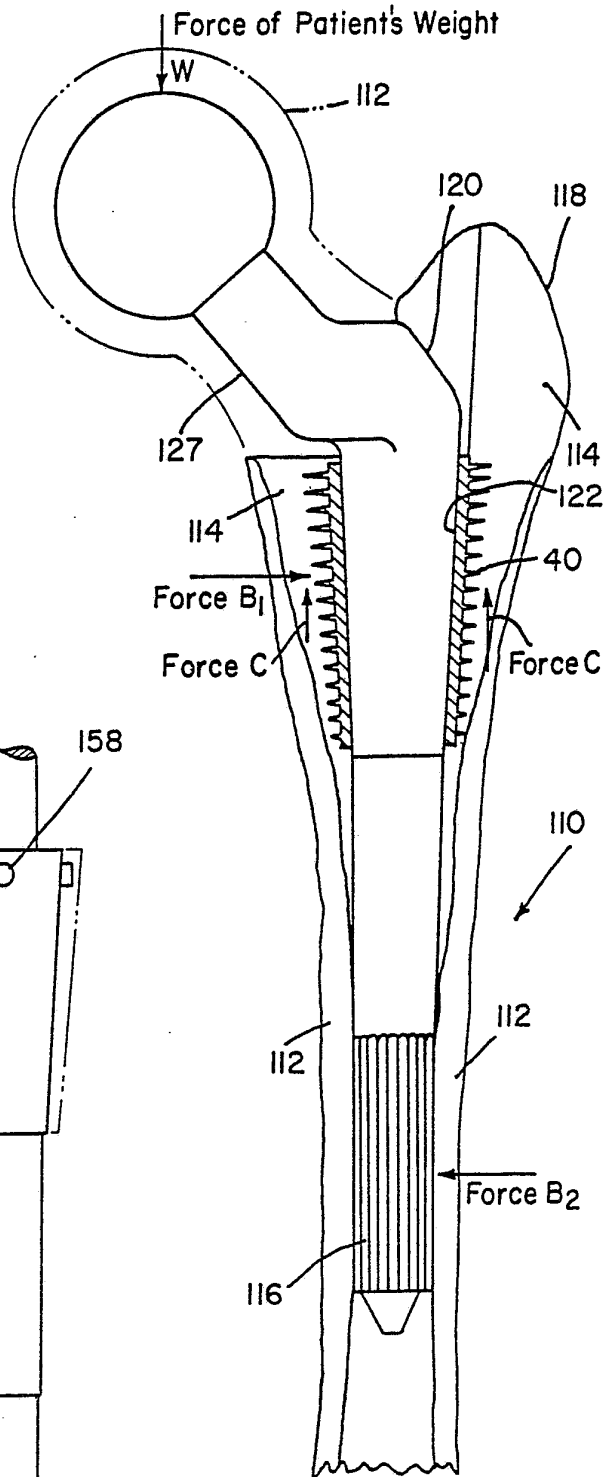

FIG. 15

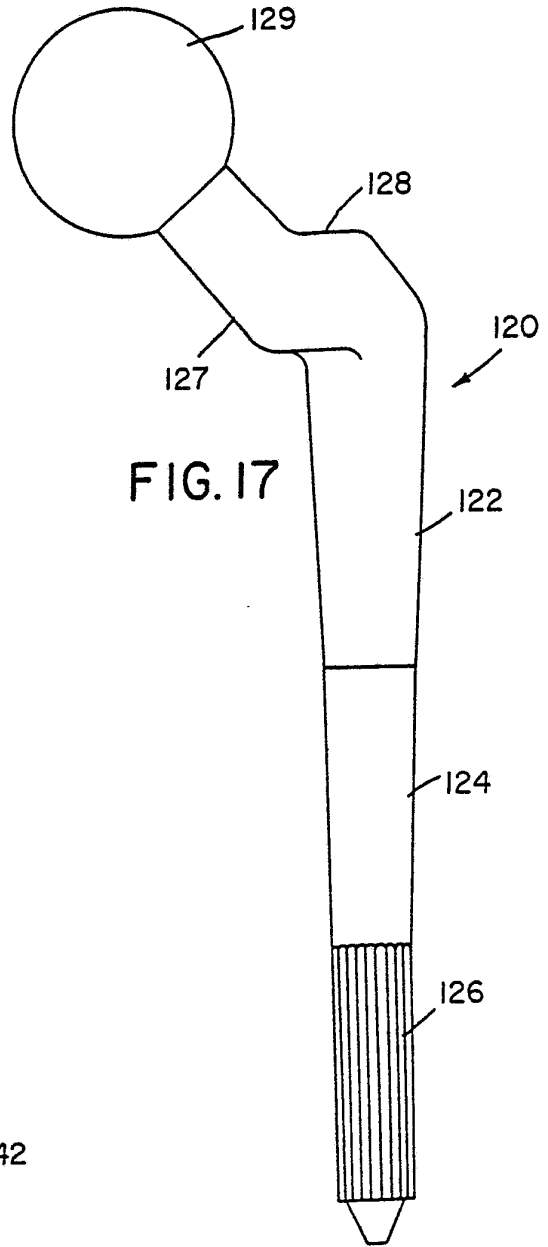

FIG. 17

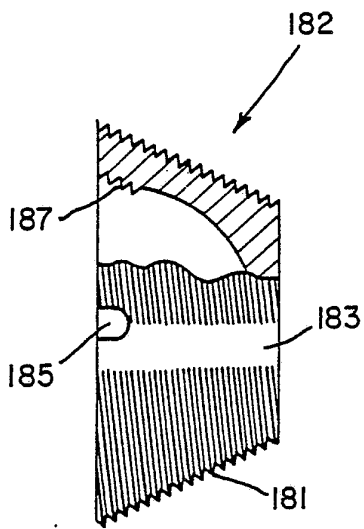

FIG. 23

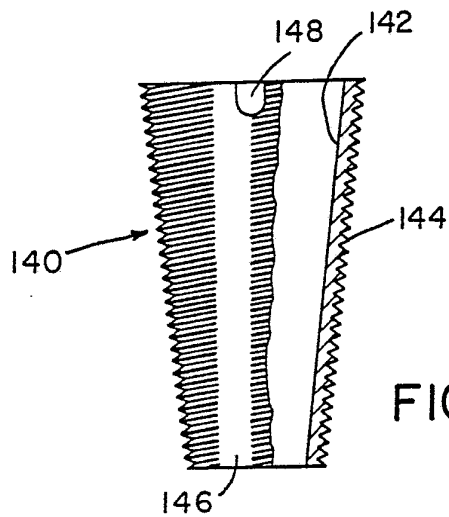

FIG. 16

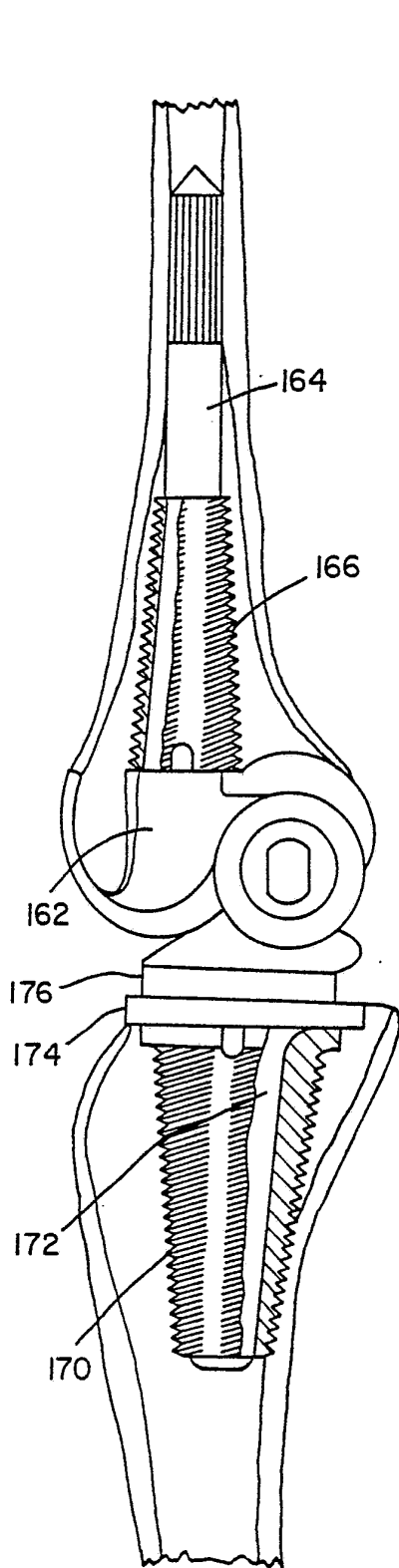

FIG. 20

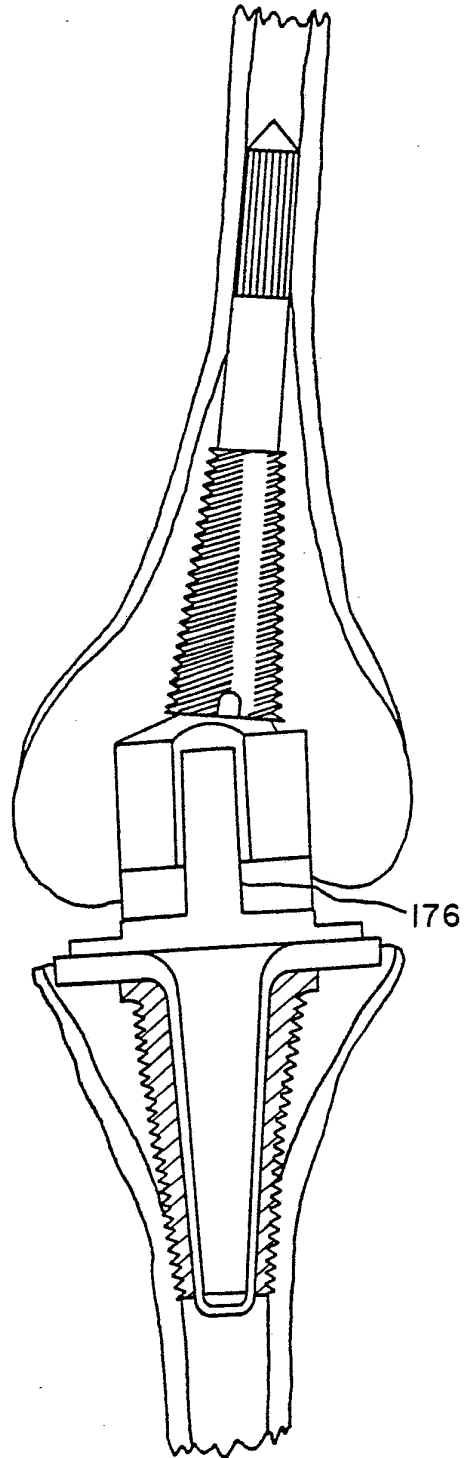

FIG. 21

FIG. 22

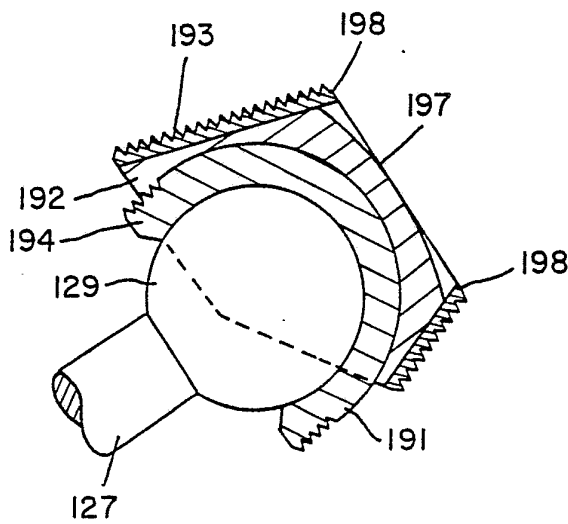
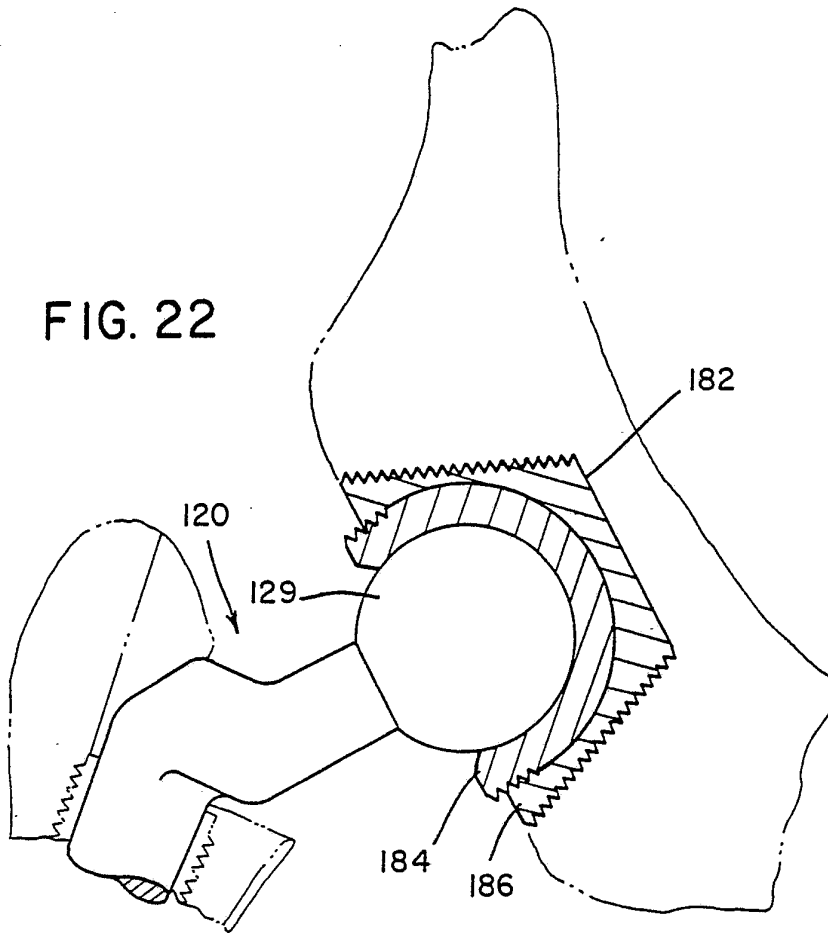
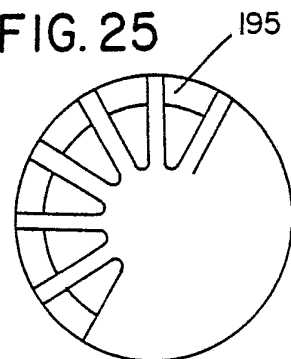

FIG. 24

FIG. 25



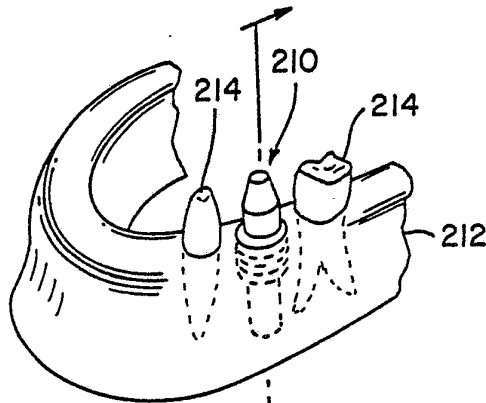

FIG. 26

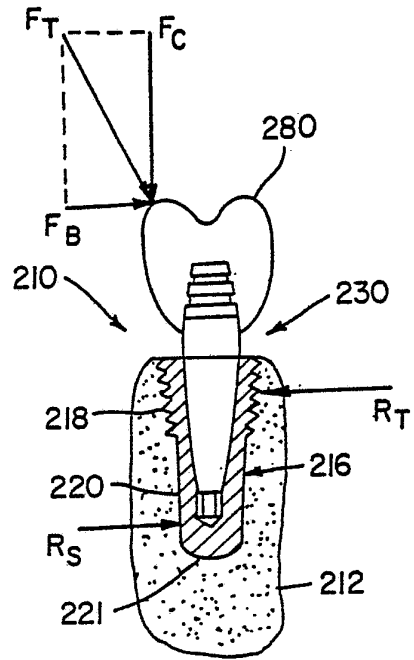

FIG. 32

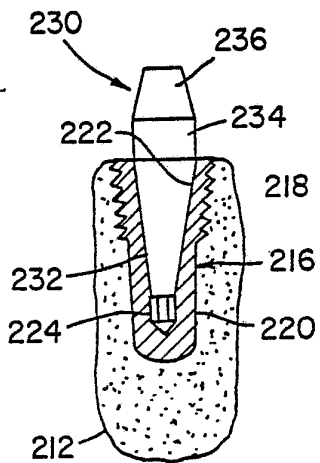

FIG. 27

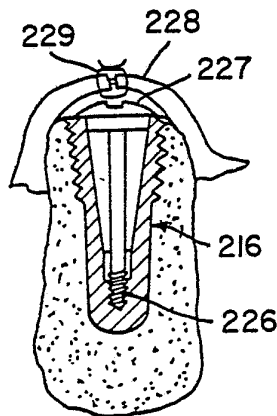

FIG. 28

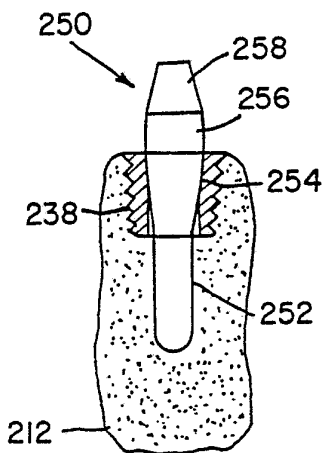

FIG. 29

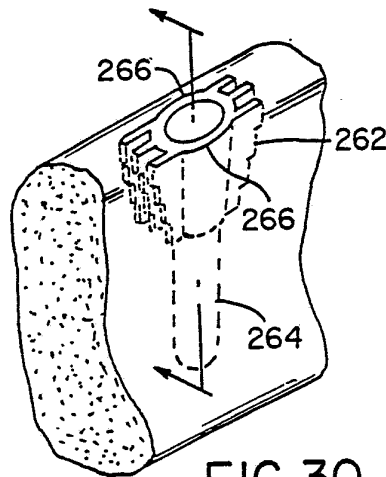

FIG. 30

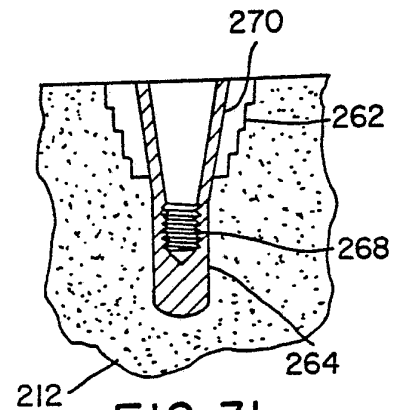

FIG. 31

INTERNATIONAL SEARCH REPORT

International Application No **PCT/US83/00089**

I. CLASSIFICATION OF SUBJECT MATTER (if several classification symbols apply, indicate all) ³		
According to International Patent Classification (IPC) or to both National Classification and IPC		
INT. CL. ³ A61F 1/00, 1/04		
U.S. CL. 3-1.9; 3-1.91 3-1.911, 3-1.912, 3-1.913		
II. FIELDS SEARCHED		
Minimum Documentation Searched ⁴		
Classification System	Classification Symbols	
U.S.	3-1.9, 1.91, 1.911, 1.912, 1.913	
	128-92C, 92CA	
Documentation Searched other than Minimum Documentation to the Extent that such Documents are Included in the Fields Searched ⁵		
III. DOCUMENTS CONSIDERED TO BE RELEVANT ¹⁴		
Category *	Citation of Document, ¹⁶ with indication, where appropriate, of the relevant passages ¹⁷	Relevant to Claim No. ¹⁸
X	E.P. A, 10,527 Published 30 April 1980 Lualdi	1,5-14,38-45
X	U.S. A. 3,848,276 Published 19 November 1974 Martinez	2-4
X	U.S. A. 4,219,893 Published 02 September 1980 Noiles	5-14
X	U.S. A. 4,259,072 Published 31 March 1981 Hirabayashi, et al.	17-37,46
X	U.S. A. 4,077,070 Published 07 March 1978 Sivash	
X	U.S. A. 3,855,638 Published 24 December 1974, Pillar	
X	U.S. A. 3,996,625 Published 14 December 1976 Noiles	
<p>* Special categories of cited documents: ¹⁵</p> <p>"A" document defining the general state of the art which is not considered to be of particular relevance</p> <p>"E" earlier document but published on or after the international filing date</p> <p>"L" document which may throw doubts on priority claim(s) or which is cited to establish the publication date of another citation or other special reason (as specified)</p> <p>"O" document referring to an oral disclosure, use, exhibition or other means</p> <p>"P" document published prior to the international filing date but later than the priority date claimed</p> <p>"T" later document published after the international filing date or priority date and not in conflict with the application but cited to understand the principle or theory underlying the invention</p> <p>"X" document of particular relevance; the claimed invention cannot be considered novel or cannot be considered to involve an inventive step</p> <p>"Y" document of particular relevance; the claimed invention cannot be considered to involve an inventive step when the document is combined with one or more other such documents, such combination being obvious to a person skilled in the art.</p> <p>"Δ" document member of the same patent family</p>		
IV. CERTIFICATION		
Date of the Actual Completion of the International Search ²	Date of Mailing of this International Search Report ²	
30 April 1983	13 MAY 1983	
International Searching Authority ¹	Signature of Authorized Officer ²⁰	
ISA/US	