

(12) STANDARD PATENT
(19) AUSTRALIAN PATENT OFFICE

(11) Application No. **AU 2005244893 B2**

(54) Title
Intravaginal device with fluid transport plates

(51) International Patent Classification(s)
A61F 13/20 (2006.01) **D04H 1/22** (2006.01)
A61F 13/15 (2006.01)

(21) Application No: **2005244893** (22) Date of Filing: **2005.05.13**

(87) WIPO No: **WO05/112856**

(30) Priority Data

(31) Number	(32) Date	(33) Country
10/848,257	2004.05.14	US
10/847,951	2004.05.14	US
60/572,054	2004.05.14	US

(43) Publication Date: **2005.12.01**

(44) Accepted Journal Date: **2011.07.28**

(71) Applicant(s)
Johnson & Johnson Consumer Companies, Inc.

(72) Inventor(s)
Binner, Curt;Glasgow, Tara;Ng, Tony, C.;Chase, David, J.;Kimball, David, L.;Carasso, Samuel C.;Danyi, Erin;Kozorovitsky, Julia

(74) Agent / Attorney
Shelston IP, Level 21 60 Margaret Street, Sydney, NSW, 2000

(56) Related Art
US 6177608
WO 1999/000096
US 4351339
US 6206867
WO 2001/001906

(12) INTERNATIONAL APPLICATION PUBLISHED UNDER THE PATENT COOPERATION TREATY (PCT)

(19) World Intellectual Property Organization
International Bureau



(43) International Publication Date
1 December 2005 (01.12.2005)

PCT

(10) International Publication Number
WO 2005/112856 A1

(51) International Patent Classification⁷: A61F 13/20,
13/15, D04H 1/22

[US/US]; 42 Carlisle Court, Somerset, NJ 08873 (US). **CARASSO, Samuel, C.** [US/US]; 12 Janet Court, Milltown, NJ 08850 (US). **CHASE, David, J.** [US/US]; 69 North Doughty Avenue, Somerville, NJ 08876 (US). **DANYI, Erin** [US/US]; 104 Bridgeway Court, Nicholasville, KY 40356 (US). **GLASGOW, Tara** [US/US]; 212 Riverwoods Drive, New Hope, PA 18938 (US). **KIMBALL, David, L.** [US/US]; 21 Greenwood Pl, Flemington, NJ 08822 (US). **KOZOROVITSKY, Julia** [US/US]; 12 Golf Club Drive, Longhorne, PA 19047 (US). **NG, Tony, C.** [US/US]; 51 Jernee Drive, East Brunswick, NJ 08816 (US).

(21) International Application Number:
PCT/US2005/017107

(22) International Filing Date: 13 May 2005 (13.05.2005)

(25) Filing Language: English

(26) Publication Language: English

(30) Priority Data:
60/572,054 14 May 2004 (14.05.2004) US
10/848,257 14 May 2004 (14.05.2004) US
10/847,951 14 May 2004 (14.05.2004) US

(74) Agents: **JOHNSON, Philip, S.** et al.; Johnson & Johnson, One Johnson & Johnson Plaza, New Brunswick, NJ 08933 (US).

(71) Applicant (for all designated States except US): **JOHNSON & JOHNSON CONSUMER COMPANIES, INC.** [US/US]; Grandview Road, Skillman, NJ 08558 (US).

(81) Designated States (unless otherwise indicated, for every kind of national protection available): AE, AG, AL, AM, AT, AU, AZ, BA, BB, BG, BR, BW, BY, BZ, CA, CH, CN, CO, CR, CU, CZ, DE, DK, DM, DZ, EC, EE, EG, ES, FI, GB, GD, GE, GH, GM, HR, HU, ID, IL, IN, IS, JP, KE, KG, KM, KP, KR, KZ, LC, LK, LR, LS, LT, LU, LV, MA, MD, MG, MK, MN, MW, MX, MZ, NA, NG, NI, NO, NZ, OM, PG, PH, PL, PT, RO, RU, SC, SD, SE, SG, SK, SL,

(72) Inventors; and
(75) Inventors/Applicants (for US only): **BINNER, Curt**

[Continued on next page]

(54) Title: INTRAVAGINAL DEVICE WITH FLUID TRANSPORT PLATES

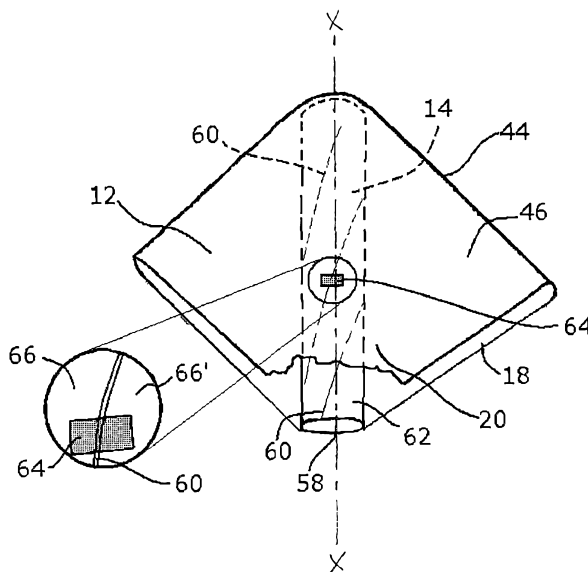

(57) Abstract: An intravaginal device has a fluid storage element and at least one fluid transport element in fluid communication with the fluid storage element. The at least one fluid transport element has a first plate and a second plate coupled to the first plate. The second plate is capable of separating from the first plate sufficiently to provide inter-plate capillary action. The at least one fluid transport element is bendable about an axis substantially parallel to the longitudinal axis of the fluid storage element. The invention also includes methods and apparatus useful in the production of an intravaginal device.

WO 2005/112856 A1



SM, SY, TJ, TM, TN, TR, TT, TZ, UA, UG, US, UZ, VC,
VN, YU, ZA, ZM, ZW.

SE, SI, SK, TR), OAPI (BF, BJ, CF, CG, CI, CM, GA, GN,
GQ, GW, ML, MR, NE, SN, TD, TG).

(84) Designated States (*unless otherwise indicated, for every kind of regional protection available*): ARIPO (BW, GH, GM, KE, LS, MW, MZ, NA, SD, SL, SZ, TZ, UG, ZM, ZW), Eurasian (AM, AZ, BY, KG, KZ, MD, RU, TJ, TM), European (AT, BE, BG, CH, CY, CZ, DE, DK, EE, ES, FI, FR, GB, GR, HU, IE, IS, IT, LT, LU, MC, NL, PL, PT, RO,

Published:

— *with international search report*

For two-letter codes and other abbreviations, refer to the "Guidance Notes on Codes and Abbreviations" appearing at the beginning of each regular issue of the PCT Gazette.

INTRAVAGINAL DEVICE WITH FLUID TRANSPORT PLATES

Field of the Invention

The present invention relates to devices for capturing and storing body fluid intravaginally. More particularly, the present invention relates to a method of capturing body fluid intravaginally via a fluid transport element and transporting the body fluid to a fluid storage element where the fluid is stored. Additionally, this application relates to methods of making such devices

Background of the Invention

Any discussion of the prior art throughout the specification should in no way be considered as an admission that such prior art is widely known or forms part of common general knowledge in the field.

Devices for capturing and storing bodily fluid intravaginally are commercially available and known in the literature. Intravaginal tampons are the most common example of such devices. Commercially available tampons are generally compressed cylindrical masses of absorbent fibers that may be over-wrapped with an absorbent or nonabsorbent cover layer.

The tampon is inserted into the human vagina and retained there for a time for the purpose of capturing and storing intravaginal bodily fluids, most commonly menstrual fluid. As intravaginal bodily fluid contacts the tampon, it should be absorbed and retained by the absorbent material of the tampon. After a time, the tampon and its retained fluid is removed and disposed, and if necessary, another tampon is inserted.

A drawback often encountered with commercially available tampons is the tendency toward premature failure, which may be defined as bodily fluid leakage from the vagina while the tampon is in place, and before the tampon is completely saturated with the bodily fluid. The patent art typically describes a problem believed to occur that an unexpanded, compressed tampon is unable to immediately absorb fluid. Therefore, it presumes that premature leakage may occur when bodily fluid contacts a portion of the

compressed tampon, and the fluid is not readily absorbed. The bodily fluid may bypass the tampon.

To overcome this problem of premature leakage, extra elements have been incorporated into a basic tampon to try to direct and control the flow of
5 fluid toward the absorbent core.

For example, US Pat. No. 4,212,301 (Johnson) discloses a unitary constructed digital tampon having a lower portion compressed preferably in the radial direction to form a rigid, rod-like element, which provides a central rigidified elongated core and an upper portion left substantially
10 uncompressed. After insertion, the uncompressed portion may be manipulated to contact the vaginal wall to provide an immediate seal against side leakage. The uncompressed portion allows for high absorbent capacity immediately upon insertion. While this tampon may allow for a certain amount of protection from bypass leakage, the uncompressed portion may
15 become saturated before the compressed portion has a chance to expand and become absorbent.

US Pat. No. 6,358,235 (Osborn et al.) discloses a "hollow" bag-like tampon that may have an interior projection made from highly compressed absorbent material. The interior projection is preferably attached to the inside
20 surface of the head of the tampon. The hollow tampon portion may include at least one pleat in the absorbent outer surface and is soft and conformable. The tampon is not pre-compressed to the point where the fibers temporarily "set" and re-expand upon the absorption of fluid. The absorbent portions of the tampon can saturate locally, which leads to bypass leakage.

US Pat. No. 6,177,608 (Weinstrauch) discloses a tampon having
25 nonwoven barrier strips which are outwardly spreadable from the tampon surface to reliably close the free spaces believed to exist within a vaginal cavity. The nonwoven barrier strips extend about the tampon in a circumferential direction at the surface or in a helical configuration about the
30 tampon and purportedly conduct menstrual fluid toward the tampon surface. The nonwoven barrier strips are attached to the cover by means of gluing, heat sealing, needle punching, embossing or the like and form pleats. The

nonwoven barrier strips are attached to the tampon blank and the blank is embossed, forming grooves extending in a longitudinal direction. While this tampon purports to direct fluid to the core, it attempts to achieve this by forming pockets of absorbent nonwoven fabric. In order to function, it appears that these pockets would have to be opened during use to allow fluid to enter. However, based upon current understandings of vaginal pressures, it is not understood how the described structure could form such an opened volume.

US Pat. No. 6,206,867 (Osborn) suggests that a desirable tampon has at least a portion of which is dry expanding to cover a significant portion of the vaginal interior immediately upon deployment. To address this desire, it discloses a tampon having a compressed central absorbent core having at least one flexible panel attached along a portion of the side surface of the core. The flexible panel appears to provide the "dry-expanding" function, and it extends outwardly from the core away from the point of attachment. The flexible panel contacts the inner surfaces of the vagina when the tampon is in place and purportedly directs fluid toward the absorbent core. The flexible panel is typically attached to the pledget prior to compression of the pledget to form the absorbent core and remains in an uncompressed state.

US Pat. No. 5,817,077 (Foley et al.) discloses a method of preserving natural moisture of vaginal epithelial tissue while using a tampon where the tampon has an initial capillary suction pressure at the outer surface of less than about 40 mm Hg. This allows the tampon to absorb vaginal secretions without substantially drying the vaginal epithelial tissue. The multiple cover layers can be used to increase the thickness of the cover material. While this represents a significant advancement in the art, this invention does not address by-pass leakage.

Additionally, US Pat. No. 5,545,155 (Hseih et al.) discloses an external absorbent article that has a set of plates separated by spacer elements. The plates may be treated to affect wettability so that fluid will flow easily across the surface. Extending through the upper plate is a plurality of openings, which allow fluid to flow with little restriction into the

space between the upper and lower plates. When the fluid flows downward in the z-direction from the upper plate to the lower plate, it will then flow laterally in the x- and y-directions. Therefore, this external absorbent article can contain fluid gushes, but it does not appear to address the problems relating in particular to intravaginal devices, such as a tampon.

It is an object of the present invention to overcome or ameliorate at least one of the disadvantages of the prior art, or to provide a useful alternative.

While the prior art is replete with examples of sanitary protection articles that capture bodily fluids both externally and intravaginally, these examples do not overcome the problem of premature failure often identified as by-pass leakage that commonly occurs while using internal sanitary protection devices. Many solutions to this problem have involved increasing the rate of expansion of a highly compressed absorbent article.

Unless the context clearly requires otherwise, throughout the description and the claims, the words "comprise", "comprising", and the like are to be construed in an inclusive sense as opposed to an exclusive or exhaustive sense; that is to say, in the sense of "including, but not limited to".

Although the invention will be described with reference to specific examples it will be appreciated by those skilled in the art that the invention may be embodied in many other forms.

Summary of the Invention

According to a first aspect of the present invention there is provided a fluid management device for use in a mammalian body, said device comprising at least one fluid transport element capable of interfacing with a body element to provide a substantially uninterrupted fluid conduit by inter-plate capillary action to a fluid storage element in fluid communication therewith; wherein the fluid transport element comprises at least a sheet-like first plate having an outwardly oriented surface and an inwardly oriented surface, and a distal portion of the at least one fluid transport element is capable of extending away from the fluid storage element.

According to a second aspect of the present invention there is provided an intravaginal device, said device comprising:

a. a fluid storage element having a longitudinal axis, an insertion end, and a withdrawal end; and

5 b. at least one fluid transport element being in fluid communication with the fluid storage element, the at least one fluid transport element comprising:

i. a first plate having an outwardly oriented surface and an inwardly oriented surface;

10 ii. a second plate coupled to the first plate; that has a first surface disposed and maintained in facing relationship with the inwardly oriented surface of the first plate and an opposite surface; and that is capable of separating from the first plate sufficiently to provide inter-plate capillary action;

15 wherein at least one of the first and second plates comprises a sheet-like material, and the at least one fluid transport element is bendable about an axis substantially parallel to the longitudinal axis of the fluid storage element, and the fluid transport element is attached to the withdrawal end of the fluid storage element.

20 According to a third aspect of the present invention there is provided an intravaginal device, said device comprising:

a. a fluid storage element having a longitudinal axis, an insertion end, a withdrawal end, and at least one longitudinal side between the insertion and withdrawal ends; and

25 b. at least one fluid transport element being in fluid communication with the fluid storage element, the at least one fluid transport element comprising:

i. a first plate having an outwardly oriented surface and an inwardly oriented surface;

30 ii. a second plate coupled to the first plate; that has a first surface disposed and maintained in facing relationship

with the inwardly oriented surface of the first plate and an opposite surface; and that is capable of separating from the first plate sufficiently to provide inter-plate capillary action; and

5 wherein at least one of the first and second plates comprises a nonwoven material, and the at least one fluid transport element is bendable about an axis substantially parallel to the longitudinal axis of the fluid storage element, and the fluid transport element is attached on at least one
10 longitudinal side of the fluid storage element.

According to a fourth aspect of the present invention there is provided an intravaginal device, said device comprising:

15 a. a fluid storage element having a longitudinal axis, an insertion end, a withdrawal end, and at least one longitudinal side between the insertion and withdrawal ends; and

 b. at least one fluid transport element being in fluid communication with the fluid storage element, the at least one fluid transport element comprising:

20 i. a first plate having an outwardly oriented surface and an inwardly oriented surface;

 ii. a second plate coupled to the first plate; that has a first surface disposed and maintained in facing relationship with the inwardly oriented surface of the first plate and an opposite surface; and that is capable of separating from the first plate sufficiently to provide inter-plate capillary action; and
25 and

 wherein at least one of the first and second plates comprises a nonwoven material, and the at least one fluid transport element is bendable about an axis substantially parallel to the longitudinal axis of the fluid storage element, and fluid transport element is attached to itself proximate the withdrawal end of the fluid storage element.
30

According to a fifth aspect of the present invention there is provided an intravaginal device, said device comprising:

a. a fluid storage element having a longitudinal axis, an insertion end, a withdrawal end, and at least one longitudinal side between the insertion and withdrawal ends; and

b. at least one fluid transport element being in fluid communication with the fluid storage element, the at least one fluid transport element comprising:

i. a first plate having an outwardly oriented surface and an inwardly oriented surface;

ii. a second plate coupled to the first plate; that has a first surface disposed and maintained in facing relationship with the inwardly oriented surface of the first plate and an opposite surface; and that is capable of separating from the first plate sufficiently to provide inter-plate capillary action; and

wherein at least one of the first and second plates comprises a nonwoven material, and the at least one fluid transport element is bendable about an axis substantially parallel to the longitudinal axis of the fluid storage element, and wherein the fluid transport element is attached to the withdrawal string to substantially envelop the fluid storage element.

Surprisingly, we have found a novel way to address the problem of premature failure. This invention is not dependent on the expansion of the compressed absorbent but rather incorporating an element, which is adaptable to the vagina. In our invention, we increase the contact area of the absorbent device and thereby reduce by-pass leakage.

In one form of the invention, the intravaginal device has a fluid storage element; a fluid transport element having a first plate having an outwardly oriented surface and an inwardly oriented surface; a second plate

that has a first surface disposed in facing relationship with the inwardly oriented surface of the first plate and an opposite surface, and that is capable of separating from the first plate sufficiently to provide inter-plate capillary action. The fluid transport element is in fluid communication with the fluid storage element and substantially encases the fluid storage element, wherein at least a portion of the outwardly oriented surface of the first plate is capable of contacting a user's vaginal epithelium.

In another form of the invention, the intravaginal device has a fluid storage element having an insertion end and a withdrawal end and a fluid transport element having a first plate having an outwardly oriented surface and an inwardly oriented surface; a second plate that has a first surface disposed in facing relationship with the inwardly oriented surface of the first plate, and an opposite surface, and that is capable of separating from the first plate sufficiently to provide inter-plate capillary action. The fluid transport element is in fluid communication with the fluid storage element and substantially encases the fluid storage element. A withdrawal string is attached to the fluid storage element such that the fluid transport element is bonded to the withdrawal string at the withdrawal end of the fluid storage element, wherein at least a portion of the outwardly oriented surface of the first plate is capable of contacting a user's vaginal epithelium.

In still another form of the invention, the intravaginal device has a fluid storage element having an insertion end and withdrawal end; a fluid transport element having a first plate having an outwardly oriented surface and an inwardly oriented surface; a second plate that has a first surface disposed in facing relationship with the inwardly oriented surface of the first plate and an opposite surface, and that is capable of separating from the first plate sufficiently to provide inter-plate capillary action. The fluid transport element is in fluid communication with the fluid storage element and substantially encases the fluid storage element, wherein the fluid storage element is attached to the withdrawal end of the fluid storage element.

In yet another form of the invention, the intravaginal device has a fluid storage element having an insertion end, a withdrawal end, and

longitudinal sides therebetween; a fluid transport element having a first plate having an outwardly oriented surface and an inwardly oriented surface; a second plate that has a first surface disposed in facing relationship with the inwardly oriented surface of the first plate and an opposite surface, and that is capable of separating from the first plate sufficiently to provide inter-plate capillary action. The fluid transport element is in fluid communication with the fluid storage element and substantially encases the fluid storage element, and wherein the fluid transport element is attached to the fluid storage element on at least one longitudinal side.

10 In still yet another form of the invention, the intravaginal device has a fluid storage element having an insertion end, a withdrawal end, and at least one longitudinal side therebetween; a fluid transport element having a first plate having an outwardly oriented surface and an inwardly oriented surface; a second plate that has a first surface disposed in facing relationship with the inwardly oriented surface of the first plate, and an opposite surface, and that is capable of separating from the first plate sufficiently to provide inter-plate capillary action. The fluid transport element in fluid communication with the fluid storage element wherein the fluid transport element is attached to the fluid storage element on at least one longitudinal side.

20 In still yet another form of the invention, the intravaginal device has a fluid storage element having an insertion end, a withdrawal end, and at least one longitudinal side therebetween; a fluid transport element having a first plate having an outwardly oriented surface and an inwardly oriented surface; a second plate that has a first surface disposed in facing relationship with the inwardly oriented surface of the first plate, and an opposite surface, and that is capable of separating from the first plate sufficiently to provide inter-plate capillary action. The fluid transport element is in fluid communication with the fluid storage element wherein the at least one longitudinal side has at least one outward surface and one inward surface and the fluid transport element is attached to the outward surface of the fluid storage element.

30 In still yet another form of the invention, the intravaginal device has a fluid transport element having a first plate having an outwardly oriented

5 surface and an inwardly oriented surface; a second plate that has a first surface disposed in facing relationship with the inwardly oriented surface of the first plate, and an opposite surface, and that is capable of separating from the first plate sufficiently to provide inter-plate capillary action; and a fluid storage element in fluid communication with the fluid transport element, the fluid storage element has an insertion end and a withdrawal end and the fluid transport element is attached to the fluid storage element at the insertion end.

The fluid transport element may be thermobondable, attached longitudinally, and include multiple plates.

10 Other aspects and features of the present invention will become apparent to those ordinarily skilled in the art upon review of the following description of specific embodiments of the invention in conjunction with the accompanying drawings.

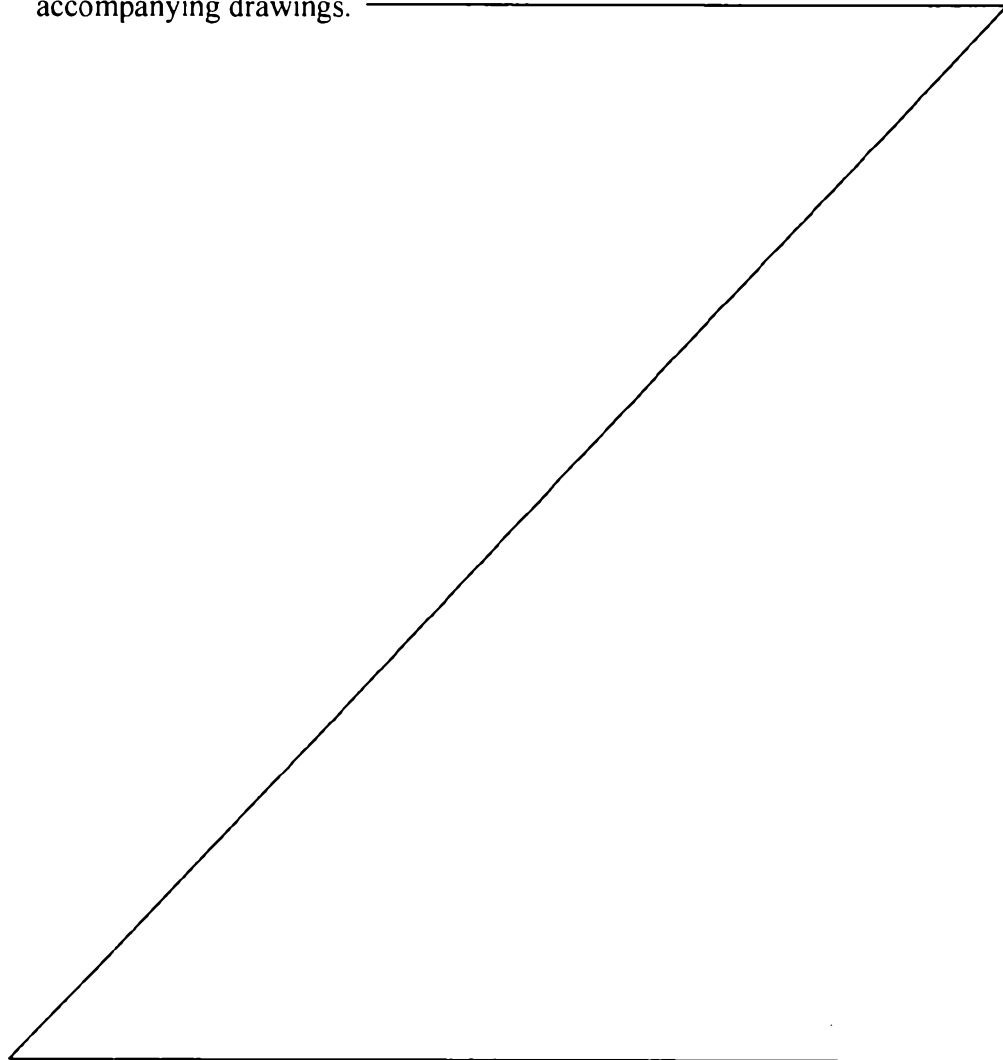

Brief Description of the Drawing

Fig 1a shows a side elevation of an intravaginal device having a fluid transport element in fluid communication with a fluid storage element.

Fig. 1b shows a cross-sectional view of the device in Fig. 1a taken along line b-b.

Fig. 1c shows the transverse cross-section shown in 1b, after the introduction of a fluid between the plates of the fluid acquisition element.

Figs. 2a-e show various aspects and orientations of an intravaginal device of the present invention.

Fig. 2a shows a perspective view of a tampon having a plurality of fluid transport elements extending therefrom that are formed from a folded sheet material.

Fig. 2b shows a side elevation of the tampon with a plurality of fluid transport elements wrapped around the fluid storage element.

Fig. 2c shows a transverse cross-section along line 2c-2c in Fig. 2b.

Fig. 2d shows a side elevation of the tampon of Fig. 2a.

Fig. 2e shows a top elevation of the tampon of Fig. 2a.

Fig. 3 shows a transverse cross-section of an alternate embodiment having a pair of fluid transport elements partially extending into the storage element.

Fig. 4a shows a side elevation of an alternate embodiment of the present invention in which a cover material is bonded to itself in the form of a bag to form a fluid transport element in fluid communication with a fluid storage element.

Fig. 4b shows a cross-sectional view of the device in Fig. 4a taken along line 6b-6b.

Fig. 5 shows a side elevation of an embodiment of the present invention in which the fluid transport element envelops the fluid storage element and is bonded at the withdrawal end to the withdrawal string.

- 9 -

Fig. 6 shows a side elevation of an embodiment of the present invention in which the fluid transport element envelops the fluid storage element and is bonded to the base of the fluid storage element.

Fig. 7 shows a side elevation of an embodiment of the present invention in which the fluid transport element is attached to the insertion end of the fluid storage element.

Fig. 8 shows a side elevation of an embodiment of the present invention in which the fluid transport element is bonded to the base of the fluid storage element.

Fig. 9 shows a bottom plan view of the embodiment shown in Fig. 8.

Fig. 10 shows a side elevation of an embodiment of the present invention in which the fluid transport element is bonded to the longitudinal side of the fluid storage element in a series of aligned discrete bonds.

Fig. 11 shows a side elevation of an embodiment of the present invention in which the fluid transport element is bonded in at least one attachment zone having discrete spots of bonds on the longitudinal side of the fluid storage element.

Fig. 12 shows an enlarged view of a section of the embodiment shown in Fig. 11.

Fig. 13 shows a schematic perspective view of apparatus according to the present invention useful to manufacture an intravaginal device.

Fig. 14 shows the schematic perspective view of apparatus of Fig. 13 including a fluid storage element and a sheet of material prior to formation of the fluid transport element.

Fig. 15 shows a schematic perspective view of a male tool useful in the apparatus of Fig. 13.

Fig. 16 shows a transverse cross-section of a human vagina with an intravaginal device according to Fig. 2b disposed therein with one fluid transport element extending away from the fluid storage element.

- 10 -

Fig. 17 shows a transverse cross-section of a human vagina with an intravaginal device according to Fig. 2b disposed therein with the fluid transport elements remaining wrapped around the fluid storage element.

Fig. 18 shows the device of Fig. 2 contained in an applicator device packaging element.

Detailed Description of the Preferred Embodiments

As used herein in the Specification and the Claims, the term “bodily fluid” and variants thereof mean bodily exudates, especially liquids that are produced by, secreted by, emanate from, and/or discharged from a human body.

As used herein in the Specification and the Claims, the term “fluids” and variants thereof relate to liquids, and especially bodily fluids.

As used herein in the Specification and the Claims, the term “sheet” and variants thereof relates to a portion of something that is thin in comparison to its length and breadth.

As used herein in the Specification and the Claims, the term “parallel plate” and variants thereof relates to a system of at least two relatively parallel sheets that are capable of moving fluids through inter-plate capillary action. The individual “plates” in the system may be flexible and/or resilient in order to move within their environment. However, they may be maintained in a substantially facing relationship with relatively constant separation at least in a localized portion of their structure (as compared with their relative length and width). Thus, two sheets could be fluted, but if the flutes were “nested”, the sheets would generally remain generally parallel in any given localized portion.

As used herein in the Specification and the Claims, the term “inter-plate capillary action” and variants thereof mean the movement of fluid due to a pressure difference across a liquid-air meniscus created within a gap between two substantially parallel plates. The two plates need not be held apart a specific

- 11 -

distance, although they should be separable to allow fluid to move between them by inter-plate capillary action. A general equation providing the rise of a fluid between parallel plates is reported as:

$$h = \frac{2\sigma * \cos \theta}{\rho * g * d}$$

in which:

h is rise of fluid between plates

σ is the surface tension of fluid in contact w/ plate

θ is contact angle

ρ is density

d is distance between plates, and

g is the gravitational constant

Therefore, as long as the contact angle, θ , is less than 90° , there will be some capillary attraction.

As used herein in the Specification and the Claims, the term “porous medium” and variants thereof relates to a connected 3-dimensional solid matrix with a highly ramified network of pores and pore throats in which fluids may flow.

As used herein in the Specification and the Claims, the term “separable plates” and variants thereof mean any condition of separation of the first plate and the second plate, which allows fluid to move between the plates. This includes situations in which facing surfaces of adjacent first and second plates are touching one another in portions of or across substantially all of their facing surfaces. This also includes situations in which the facing surfaces of the adjacent first and second plates are separably joined together such that upon contact with fluid, the surfaces separate enough to provide for fluid to move between them. This further includes situations in which facing surfaces of adjacent first and second plates are joined together, as long as fluid may still move freely between the surfaces.

- 12 -

As used herein in the Specification and the Claims, the term “in fluid communication” and variants thereof relate to elements that are arranged and configured to allow fluid to move therebetween.

As used herein in the Specification and the Claims, the term “coupled” and variants thereof relate to the relationship between two portions of an integral structure that are either portions of the same material (e.g., two portions of a folded sheet) or are materials that are joined together (e.g., two separate sheets that are bonded together).

As used herein in the Specification and the Claims, the term “fluid pervious” and variants thereof relate to a material that permits fluid or moisture to pass through without additional processing, such as aperturing. Therefore, for example, an untreated woven or nonwoven material is fluid pervious and a continuous, plastic film or metal foil is not. A nonwoven permits fluid flow via the interstices between fibers, such that fluid can flow through, either by capillary action and/or via a pressure differential from one side of the nonwoven to the other such as the pressure experienced by a tampon in use.

Referring to Fig. 1a-1c, this invention provides an intravaginal device 10 having at least one fluid transport element 12 in fluid communication with a fluid storage element 14 (Figs. 1a-1c show two fluid transport elements 12 located on opposite sides of the fluid storage element 14). The device may also include a withdrawal mechanism, such as a string 16.

The fluid storage element can be any convenient shape including cylindrical, cup like, hourglass, spherical, etc. It can be an absorbent or a fluid collection device. It can be in separate sections with the fluid transport element(s) bridging or connecting the sections.

The storage element can be made of any material known in the art such as cotton, rayon, polyester, superabsorbent materials, and the like. The fluid storage element can be made of any composition known in the art, such as compressed

- 13 -

fibrous webs, rolled goods, foam, and the like. The material may be formed as a unitary mass or a plurality of discrete particles or agglomerations. The material may be compressed to maintain a relatively stable form, or it may be left relatively uncompressed. For example, the absorbent material may include a central portion of absorbent wood pulp material. The pulp may be covered by a thin absorbent woven or nonwoven fabric and may be coterminous with the fluff pad or completely envelop it on all sides. Absorbent materials which are uncompressed or of low density have a much higher holding capacity for fluids than high density materials. A consideration for using uncompressed materials is the bulk or volume that may be required in order to achieve sufficient absorbency.

In one preferred embodiment, the fluid storage element 14 is an absorbent tampon. Absorbent tampons are usually substantially cylindrical masses of compressed absorbent material having a central axis and a radius that defines the outer circumferential surface of the tampon. Such tampons are disclosed in e.g., Haas, US Pat. No. 1,926,900; Dostal, US Pat. No. 3,811,445; Wolff, US Pat. No. 3,422,496; Friese et al., US Pat. No. 6,310,296; Leutwyler et al., US Pat. No. 5,911,712, Truman, US Pat. No. 3,983,875; Agyapong et al., US Pat. No. 6,554,814. Tampons also usually include a fluid-permeable cover (which may include or be replaced by another surface treatment) and a withdrawal string or other removal mechanism.

Absorbent materials useful in the formation of the absorbent body include fiber, foam, superabsorbent, hydrogels, and the like. Preferred absorbent material for the present invention includes foam and fiber. Absorbent foams may include hydrophilic foams, foams that are readily wetted by aqueous fluids as well as foams in which the cell walls that form the foam themselves absorb fluid.

Fibers may be selected from cellulosic fiber, including natural fibers (such as cotton, wood pulp, jute, and the like) and synthetic fibers (such as regenerated

- 14 -

cellulose, cellulose nitrate, cellulose acetate, rayon, polyester, polyvinyl alcohol, polyolefin, polyamine, polyamide, polyacrylonitrile, and the like).

The fluid storage element may also be in the form of a collection cup. Examples of such devices are disclosed in Zoller, US Pat. No. 3,845,766 and Contente et al., US Pat. No. 5,295,984. Collection devices are designed to assume a normally open, concave configuration, with an open side facing a user's cervix. The collection devices may be folded, or otherwise manipulated, to facilitate insertion into the vaginal canal

The fluid transport element has at least a first plate 18 and a second plate 20. The first and second plates combine to provide a set of parallel plates, and the fluid transport elements 12 are shown as extending radially away from the fluid storage element 14. Additional plates may also be incorporated into each fluid transport element 12.

The plates are configured and arranged to allow the introduction of bodily fluid 22 to separate a plate from adjacent plate(s) (Fig. 1c). At least one opening 24 allows the introduction of bodily fluids 22. Optionally, one or more spacer elements 26 can be inserted to establish and to maintain space between adjacent plates.

Fig. 1b shows a pair of parallel plates prior to the introduction of a fluid. In this view, the facing surfaces of the adjacent plates 18, 20 are in contact. On the other hand, Fig. 1c shows the set of parallel plates separated by a bodily fluid 22, providing an inter-plate capillary gap 28 between the inwardly oriented surface 30 of the first plate 18 and the first surface 32 of the second plate 20. This inter-plate capillary gap 28 is sufficient to provide inter-plate capillary action to allow the fluid transport element 12 to acquire, to spread, and to move bodily fluids 22 from the vagina to the fluid storage element 14. The first plate 18 also has an outwardly oriented surface 34, and the second plate 20 also has an opposite surface 36.

The plates 18, 20 can be made of almost any hydrophobic or hydrophilic material, preferably sheet-like. The thickness of each plate is not critical. However,

- 15 -

it can preferably be selected from the range of from about 0.005 to about 0.050 inch. The materials of construction and the thickness of the plates should be designed so that they are sufficiently stiff and/or resistant to wet collapse when exposed to fluid. Preferably, the sheet-like material is a relatively smooth nonwoven material. If the fluid storage element has properties appropriate for the fluid transport element, the two elements may be formed of the same material.

In particular, materials useful for forming the fluid transport element may have properties such as thermobondability to provide means to incorporate it into the intravaginal device. A representative, non-limiting list of useful materials includes polyolefins, such as polypropylene and polyethylene; polyolefin copolymers, such as ethylenevinyl acetate ("EVA"), ethylene-propylene, ethyleneacrylates, and ethyleneacrylic acid and salts thereof; halogenated polymers; polyesters and polyester copolymers; polyamides and polyamide copolymers; polyurethanes and polyurethane copolymers; polystyrenes and polystyrene copolymers; and the like. The fluid transport element may also be micro-embossed or apertured.

The fluid transport element 12 may also be constructed from a tissue or layers of tissue. One suitable tissue is an airlaid tissue available from Fort Howard Tissue Company of Green Bay, Wisconsin, and having a basis weight of about 35 lbs./3000 ft². Another suitable airlaid tissue is available from Merfin Hygenic Products, Ltd., of Delta, British Columbia, Canada, having a basis weight of about 61 lbs./ 3000 ft² and having the designation grade number 176.

As previously stated, the fluid transport element may be made from a fibrous nonwoven material. In one embodiment, the nonwoven material can be made from natural fibers, synthetic fibers, or a blend of synthetic and natural fibers that permit fluid to pass through to a fluid storage element. The nonwoven material can be hydrophilic or hydrophobic. The cover material can be used as is or can be apertured by methods known in the art to be an apertured, fluid pervious material. Apertures permit relatively viscous fluid, or fluid having some solids content, such

- 16 -

as menses, to pass relatively unimpeded through the fluid pervious material such that it can be readily absorbed by the fluid storage element. The apertures permit the fluid, such as menses, to penetrate deeper into the article to improve the masking property of the article. Therefore, the fluid pervious, preferably nonwoven, fluid transport element of the present invention permits fluid transport to and absorption into the fluid storage element.

In one embodiment, the fluid transport element is hydrophobic, or rendered hydrophobic, such that absorbed fluid is attracted to, or remains in, the fluid storage element, not in the fluid transport element. Because of the relatively poor wicking propensity of the hydrophobic fluid transport element, the fluid transport element remains relatively free of menses, giving a cleaner visual appearance to the post-use intravaginal device. In one embodiment, apertures provide for improved fluid flow into the core, and better visual appearance post use. By providing apertures in the fluid transport element, fluid absorption of relatively viscous fluid can be enhanced due to the lack of any obstruction to fluid absorption via the apertures. The cover remains relatively free of menses, and appears less soiled and closer to its original appearance. This provides the appearance of overall cleanliness.

It may be helpful to keep the exposed surface of the fluid transport element as smooth as possible. It may also be helpful to provide it with a low coefficient of friction. These characteristics may provide at least two benefits: (1) the force required to insert the intravaginal device is reduced, and (2) it reduces the damage otherwise caused by scraping of soft, tender vaginal tissue during insertion, wearing and removal. Plates 18 and 20 may be made from the same material or alternately, plate 18 may be made from a different material than plate 20.

The parallel plates can have any physical structure to provide a resistance to fluid flow vector in the direction parallel to the inwardly oriented surface 30 of the first plate 18 and the first surface 32 of the second plate 20 that is less than the resistance to fluid flow vector in the direction perpendicular to the plates.

- 17 -

Preferably, the plates are made from any smooth material with a non-fibrous surface and are able to transport fluid between the two layers.

The fluid transport element 12 should be strong enough to prevent rupturing during handling, insertion, and removal and to withstand vaginal pressures during use.

It is preferable that the surfaces of the fluid transport element 12 are sufficiently wettable by the bodily fluids that the intravaginal device 10 is intended to collect (this results largely from a correlation of the surface energy of the plate surface and the bodily fluid(s)). Thus, the bodily fluid will easily wet the plate, and capillarity between the plates will draw these bodily fluids from a source to a fluid storage element that is in fluid communication with the fluid transport element.

Surface treatments can be used to modify the surface energy of the plates 18, 20. In a preferred embodiment a surfactant is applied to increase the wettability of the outer or inner surfaces of the parallel plates. This will increase the rate at which the bodily fluids are drawn into and spread between a pair of plates. The surfactant can be applied uniformly to either the inner or outer surfaces or it could be applied with varying coating weights in different regions.

A useful measure to determine the wettability of a plate surface is its contact angle with 1.0 % saline. Preferably, the contact angle with 1.0% saline is less than about 90 degrees.

In order to accomplish this, the materials of plates can be chosen from those materials that are known in the art to have low energy surfaces. It is also possible and useful to coat materials that have high-energy surfaces with a surface additive, such as a non-ionic surfactant (e.g., ethoxylates), a diol, or mixtures thereof, in order to increase their wettability by bodily fluids. Such additives are well known in the art, and examples include those described in Yang et al., US App. No. 2002-0123731-A1, and US Pat. No. 6,570,055. Other means of increasing wettability can

- 18 -

also be used, such as by corona discharge treatment of, for example, polyethylene or polypropylene, or by caustic etching of, for example, polyester.

The parallel plates forming the fluid transport element can be of any flexibility as long as the material is able to transport fluid to the fluid storage element while the device is in use. It is also preferable that the fluid transport element be sufficiently flexible to provide the user with comfort while inserting, wearing, and removing the device.

The surfaces of the first and second plates facing each other can have a variety of surface textures, ranging from smooth to highly textured. The texturing element may be included as a spacer 26.

The value of spacers 26 or texture may be based on the material's ability to withstand wet collapse when simultaneously subjected to compressive forces and fluid.

The spacer elements 26 can be separate elements applied to one or more of the plates, or they can be integral portions of a plate that extend away from one of the plate's major surfaces. A representative list of such separate spacer elements includes, without limitation, foamed materials such as polystyrene foam; particles such as beads and crystals; discontinuous material such as netting, thread, wax, adhesive, any discrete element that causes a separation between the plates and the like.

Integral spacer elements can be thickened portions of the plate material or deformations of the plate material. A representative list of such an integral spacer element includes, without limitation, nubbles, embossments, corrugations, deformations, and the like. Included in this definition are surface treatments that permanently bond a secondary material to a surface of a first. The spacer elements also increase the texture of the plates. While not wishing to be held to this theory, it is believed that the texturing reduces the viscosity of the fluid being transported. The texture can also be in a gradient. For example, in one embodiment, the texture

- 19 -

of the plates has a gradient from smooth near the edge of the plates where the fluid enters the fluid transport element to more textured where the fluid is absorbed.

In order to maintain stability against sliding of the plates with respect to each other and changing of the space between them, it is acceptable, and may be preferable, to secure some local areas of contact between the spacer elements 26 and the adjacent plate or even between spacer elements 26 of two adjacent plates. The plates may be secured through means known to those of ordinary skill in the art. A representative list of such securing means includes, without limitation, thermobonding, adhering, crimping, embossing, ultrasonic bonding or welding, and the like. The adhesive may be applied between the spacer elements and the first and second plates. Preferably, the adhesive is wettable.

Referring for example, to Figs. 2 and 3, the first and second plates 18, 20 may be extensions of the same sheet-like material, e.g., formed by a fold in a sheet of material (as shown in Figs. 2a-2c), or they may be separate elements (i.e., adjacent to each other but not necessarily joined). In a folded embodiment, the material is preferably folded to form a pleat with the first and second plates facing each other.

A preferred embodiment with pleats is shown in Figs. 2a-2e, where the pleats 44 are folds in the cover material 46. The pleats 44 create plates that are bendable about an infinite number of bending axes (b_{1-i} - b_{1-i}) that are substantially parallel to the longitudinal axis (X-X) of the product, which longitudinal axis extends through the insertion end 48 and withdrawal end 50. These bending axes allow the plates to wrap around the product, either partially or completely. One such bending axis (b_1 - b_1) is shown in Fig. 2a.

The fluid transport element 12 is in fluid communication with the fluid storage element 14 and directs fluid from the vagina to the storage element 14. Generally, fluid will be directed from each fluid transport element 12 to a particular region of the fluid storage element associated with that fluid transport element.

- 20 -

Thus, if the device has only one fluid transport element 12, the fluid will contact the fluid storage element in one interface 52.

Therefore, additional fluid transport elements 12 directing fluid to additional locations of the fluid storage element 14 will improve the efficient usage of the fluid storage element 14. For example, two fluid transport elements 12 could be directed to opposite sides of the fluid storage element 14, as shown in Figs. 1a-1c. Each additional fluid transport element 12 can direct fluid to additional interface locations 52 of the fluid storage element 14. For example, four evenly spaced fluid transport elements 12 allow fluid to be directed to each quarter of the fluid storage element 14 surface as shown in Figs 2a-e. Five or more elements would provide even more direct access. This can allow the fluid to contact the fluid storage element 14 uniformly and help to prevent or reduce local saturation of the fluid storage element 14.

While the above description provides for direct fluid communication between a fluid transport element 12 and the fluid storage element 14, direct fluid contact is not necessary. There can be fluid communication through an intermediate element, such as a porous medium (e.g., a foam or fibrous structure), a hollow tube, and the like.

Enlarging the area of the interface 52 between the fluid transport element 12 and fluid storage element 14 can also help to maximize the fluid communication. For example, elongating the interface by increasing the length of the fluid transport element 12 allows more fluid to flow into the fluid storage element 14.

The fluid transport element 12 may extend in any orientation from the surface of the fluid storage element 14. It is not necessary for the fluid transport element to be on the surface of the fluid storage element.

The inter-plate capillary gap 28 formed by first plate 18 and second plate 20 can terminate at the interface 52 or can extend into and/or through the fluid storage element 14. An example of the fluid transport element 12 extending into the fluid

- 21 -

storage element 14 is shown in Fig. 3. The first and second plates can have additional layers on top of them as long as these additional layers allow fluid to enter the plates. The first and second plates can end at the boundary of the transport element or can extend into the fluid storage element 14.

The fluid transport element 12 may be formed to extend from the surface of the fluid storage element 14 as in Figs. 1a-1c. It can be made in any convenient shape, including semicircular, triangular, square, hourglass etc. Additionally the two plates of the element do not have to be completely coextensive, as long as they are at least partially in a facing relationship.

Parallel plates can be held in close proximity to the storage element in a variety of ways including directly or indirectly via an additional element to the storage element. A variety of methods can be used to attach the fluid transport element 12 including but not limited to heat, adhesive, ultrasonic, sewing, and mechanically engaging the fluid storage element 14. An example of a heat-bonded attachment 54 is shown in Fig. 2a.

The fluid transport element(s) 12 can be attached at the sides, insertion end 48, and/or withdrawal end 50 of the intravaginal device. Additionally, the fluid transport element(s) 12 may be attached to themselves and not to the storage element as in a relatively loose bag covering of the storage element. The fluid transport element(s) 12 could also be attached to the withdrawal string.

The fluid transport element may be attached directly to the fluid storage element or may be attached to itself in one or more locations. Such attachment or adherence to itself or to the fluid storage element may be by any known means, including, for example, adhesive, ultrasonic, co-embossing, thermobonding, mechanical bonding (such as crimping), and the like. In one embodiment, the fluid transport element is formed of a material that is capable of being thermobonded. Alternately, the material may be formed of two different materials having different melting points, at least one of which would also be capable of thermobonding.

- 22 -

In an embodiment shown in Figs. 4a and 4b, the cover material 46 substantially envelops the fluid storage element 14 (shown as a tampon), forming a bag or sack structure 56. This structure provides a pair of fluid transport elements 12' formed by portions of the cover material 46. In this embodiment, the cover material 46 is draped over the insertion end 48 of the tampon with the edges of the material brought together about the withdrawal end 50 and then bonded to itself 54'. The resulting fluid transport element 12' can then be folded around the tampon in the manner shown in Fig. 2b.

Other embodiments similar to that shown in Fig. 4 are possible. For example, Fig. 5 shows the attachment 54'' of the fluid transport element 12 to the withdrawal string 16, and Fig. 6 shows the attachment 54''' at the withdrawal end 50, especially to the base 58 of the fluid storage element 14 (the base 58 being the generally circular surface from which the withdrawal string 16 may extend). In all of these embodiments, the cover material 46 and the associated fluid transport element 12 substantially envelop the fluid storage element 14 but do not significantly affect the performance of the fluid storage element 14. For example, if the fluid storage element 14 had been compressed and expands upon exposure to fluid, the expansion of the fluid storage element 14 would not be affected or inhibited by the attachment or bonding of the fluid transport element 12 to the fluid storage element 14.

In the embodiments described and shown in Figs. 4-6, it is not necessary for the fluid storage element 14 to be a unitary element. For example, the fluid storage element 14 may have multiple distinct portions or segments. The segments may be attached together or may be discrete. Examples of discrete segments may be relatively loose absorbent material or compressed cellulosic tablets. However, these discrete segments could be at least partially contained to permit the fluid transport element 12 to form parallel plates, as described above.

- 23 -

In an alternate embodiment of the invention shown in Fig. 7, the fluid transport element 12 and the fluid storage element 14 have an attachment 54 at the insertion end 48 of fluid storage element 14. Pleats 44 formed in the fluid transport element 12 may be folded around the tampon as previously shown in Fig. 2b. Additionally, the lower portions 60 of the sheet material may also be attached to withdrawal end 50 of the fluid storage element 14, as described above and below, to prevent inversion of the fluid transport element 12 upon withdrawal.

In embodiments where the fluid transport element 12 is bonded or gathered at the withdrawal end 50 of the fluid storage element 14, it is preferable to minimize bunching of the fluid transport element 12 material to limit interference during insertion and withdrawal of the device.

Although not required, the sheet material used to form the fluid transport element 12 may initially be in a shape such that the sheet has at least one corner. The sheet material is placed over the fluid storage element 14 such that at least one portion of the sheet extends away from the fluid storage element 14. In one embodiment, the sheet has a plurality of corners, and each corner may be attached to the withdrawal end 50 of the fluid storage element 14. For example, if four sets of parallel plates are desired, the sheet material may be a square.

If the fluid storage element 14 is a compressed tampon having embossed grooves such as those disclosed in US Pat. No. 5,165,152 the disclosure of which is hereby incorporated by reference, the attachment may be on the outer most surface (non-embossed) or in the grooves. Attachment may take place before, during, and/or after fluid storage element 14 compression.

The embodiment of Figs. 8 and 9 is similar to that of Fig. 7. In particular, the corners of the fluid transport element 12 are attached to the base 58 of the fluid storage element 14. As seen in Fig. 9, the corners preferably do not overlap the center of the circular base 58.

- 24 -

When a compressed tampon having grooves 60 is used as the fluid storage element 14, it is likely that the tampon performs optimally if permitted to expand without restriction by the fluid transport element. While some compressed tampons expand due to dry expansion, others expand when exposed to fluid. One example of such a compressed tampon having grooves is the o.b.® tampon available from McNEIL-PPC, Inc., Skillman, NJ.

In the embodiments shown in Figs. 10-12, the fluid storage element 14 is a compressed tampon having an exterior surface 62 and grooves 60. Grooves 60 have an interior portion, which becomes part of the exterior surface 62 of the tampon upon absorption of fluids and the resultant tampon expansion. Because the fluid transport element 12 is attached to the exterior surface 62 of the tampon at its withdrawal end 50, it does not extend into the tampon grooves 60. Thus, the fluid storage element 14 may expand without any interference from the fluid transport element 12. In other words, the fluid transport element 12 does not significantly limit the functionality of the fluid storage element 14. Pleats 44' form in the fluid transport element 12 and may be similarly folded around the tampon as previously shown in Fig. 2b.

As shown in Fig. 10, a tampon having straight grooves is attached to the fluid transport element 12 using a series of heat bonds 54 along one or more single line(s) along the tampon. This provides easier alignment of the attachment 54 and the exterior surface 62 of the tampon as the bond line may be registered accurately to avoid coinciding with the grooves 60. Thus, the fluid transport element 12 may be readily attached along the longitudinal side without interfering with the expansion of the tampon.

In a similar embodiment shown in Figs. 11 and 12, the fluid transport element 12 may be attached along the longitudinal side of a tampon having spirally oriented grooves. In this embodiment an attachment zone 64 of fluid transport element 12 extends from one lobe 66 and across groove 60 to adjacent lobe 66'.

- 25 -

Materials such as nonwoven webs have a certain amount of elasticity and may be designed to permit the tampon expansion, especially the material located within the interior portion of the grooves 60.

If desired, the attachment zone 64 may be oriented in any direction relative to the longitudinal axis X-X of the fluid storage element 14. As shown in Figs. 11 and 12, the attachment zone 64 comprises a matrix or other grouping of discrete bonds, such as dots or spots. This allows the interface between the fluid transport element 12 and the fluid storage element 14 to remain as open to fluid flow as possible.

As previously mentioned and shown, the fluid transport element 12 may be attached to the fluid storage element 14 by any number of methods and embodiments. For example and with reference to Figs. 13-15, a tampon may be manufactured as shown in Friese, US Pat. No. 4,816,100, and either Friese et al., US Pat. No. 6,310,269, or Leutwyler et al., US Pat. No. 5,911,712. However, after the tampon is formed and prior to packaging, an additional process employing a forming tool 102, a male tool 104 having a plurality of blades 106, and thermobonding elements 108 applies a fluid transport element 12 to the fluid storage element 14. The tools are aligned in a manner that the blades 106 of the male tool 104 cooperate with corresponding slots 110 in the forming tool 102. In addition, each of the tools has a central aperture 112, 112' through which a fluid storage element 14 may pass during processing.

In somewhat more detail, an individual sheet 114 of material is separated from a supply (not shown) and placed on the forming tool 102. A vacuum is drawn across the forming tool 102 via a plurality of vacuum ports 116 on the face 118 of the forming tool 102 to hold the individual sheet 114 in place.

The blades 106 of the male tool 104 are shown arranged radially about the central aperture 112 in the male tool 104 (as shown in Fig. 15). The blades 106 cooperate to hold the fluid storage element 14 in line with the central aperture 112.

- 26 -

A pushrod (not shown) is arranged to penetrate the central aperture 112 of the male tool 104 and to bear on the base of the fluid storage element 14. In the preferred embodiment shown in Figs. 13-15, four blades 106 are arranged at equal angles about the central aperture 112. Each blade 106 provides a guide edge 120 facing the fluid storage element 14 (when present) and a pleating edge 122 disposed radially outwards from the guide edge 120. The pleating edge 122 may be an edge that is adjacent the guide edge 120, or it may be separated by one or more intermediate portions of the blade 106.

In operation, the male tool 104 holding a fluid storage element 14 is moved along the machine axis (M-M) aligned with the central apertures 112, 112' toward the forming tool 102 carrying the individual sheet 114. The insertion end 48 of the fluid storage element 14 contacts the individual sheet 114 and urges it through the central aperture 112' of the forming tool 102. The pleating edges 112 of the blades 106 urge corresponding portions of the individual sheet 114 through the slots 110 of the forming tool 102 creating four sets of parallel plates 18, 20.

Once the fluid storage element 14 is inserted into the central aperture 112' of the forming tool 102 with only a portion of the withdrawal end 50 remaining exposed, thermobonding elements 108 extend into the space between the blades 106 to bond the four corners of the individual sheet 110 to the exterior surface 62 of the fluid storage element 14, forming the fluid transport element 12. The pushrod may then continue to move the insertable device 10 into and through the central aperture 112' of the forming tool 102. The fluid transport element 12 may then be folded about the fluid storage element 14. The resulting insertable device may then be packaged in a hygienic overwrap as is well known in the art.

While the process described above in reference to Figs. 13-15 employs blades 106 that have a guide edge 120 that is shorter than the fluid storage element 14, this relationship may be altered. For example, the blades 106 could be modified to have a guide edge 120 that is longer than the fluid storage element 14 or the

- 27 -

system could otherwise be modified to allow the leading portions 124 to contact the individual sheet 114, first. This permits the formation of a small gap between the insertion end 48 of the tampon and the individual sheet 114 that may allow more free expansion of the tampon without restriction by the fluid transport element 14 during use.

During use, fluid transport element(s) 12 can take on many configurations within the vagina. For example, a fluid transport element 12 may extend into the vagina away from the fluid storage element 14, as shown in Fig. 16. Alternatively, and the fluid transport element(s) 12 may remain wound about the fluid storage element 14, contacting the vaginal wall "W" only through the first surface 30 (Fig. 17).

A withdrawal mechanism, such as withdrawal string 16, is preferably joined to the intravaginal device 10 for removal after use. The withdrawal mechanism is preferably joined to at least the fluid storage element 14 and extends beyond at least its withdrawal end 50. Any of the withdrawal strings currently known in the art may be used as a suitable withdrawal mechanism, including without limitation, braided (or twisted) cord, yarn, etc. In addition, the withdrawal mechanism can take on other forms such as a ribbon, loop, tab, or the like (including combinations of currently used mechanisms and these other forms). For example, several ribbons may be twisted or braided to provide parallel plates structures.

Tampons are generally categorized in two classes: applicator tampons and digital tampons, and a certain amount of dimensional stability is useful for each type of tampon. Applicator tampons use a relatively rigid device to contain and protect the tampon prior to use. To insert the tampon into a body cavity, the applicator containing the tampon is partially inserted into the body cavity, and the tampon can be expelled from the applicator into the body cavity. In contrast, digital tampons do not have an applicator to help guide them into the body cavity and require sufficient column strength to allow insertion without using an applicator.

- 28 -

While the applicator tampon is protected by the rigid applicator device and the applicator tampon need not as have as high a degree of column strength as a digital tampon, applicator tampons do require dimensional stability (especially radial) to be acceptable for use. This dimensional stability provides assurance, for example, that the tampon will not prematurely grow and split its packaging material or become wedged in a tampon applicator.

Further, the intravaginal device can be collapsed for packaging and insertion. For example, at least a portion of a major surface of the fluid transport element 12, such as the first surface 30, may be in contact with at least a portion of an outer surface of the fluid storage element 14. This can be achieved by wrapping the fluid transport element(s) around the fluid storage element 14 (as shown in Fig. 2b). Alternatively, the fluid transport element(s) 12 may be folded or pleated (e.g., in an accordion-like manner) against the fluid storage element 14. The thus-compacted device can then be packaged, (e.g., within an applicator or alone in a wrapper). Fig. 18 shows a wrapped tampon within an applicator 68 (in phantom).

The specification and embodiments above are presented to aid in the complete and non-limiting understanding of the invention disclosed herein. Since many variations and embodiments of the invention can be made without departing from its spirit and scope, the invention resides in the claims hereinafter appended.

THE CLAIMS DEFINING THE INVENTION ARE AS FOLLOWS:-

1. A fluid management device for use in a mammalian body, said device comprising at least one fluid transport element capable of interfacing with a body element to provide a substantially uninterrupted fluid conduit by inter-plate capillary action to a fluid storage element in fluid communication therewith; wherein the fluid transport element comprises at least a sheet-like first plate having an outwardly oriented surface and an inwardly oriented surface, and a distal portion of the at least one fluid transport element is capable of extending away from the fluid storage element.
5
 2. A device according to claim 1, wherein the fluid transport element comprises a nonwoven material.
 3. An intravaginal device, said device comprising:
15
 - a. a fluid storage element having a longitudinal axis, an insertion end, and a withdrawal end; and
 - b. at least one fluid transport element being in fluid communication with the fluid storage element, the at least one fluid transport element comprising:
20
 - i. a first plate having an outwardly oriented surface and an inwardly oriented surface;
 - ii. a second plate coupled to the first plate; that has a first surface disposed and maintained in facing relationship with the inwardly oriented surface of the first plate and an opposite surface;
25 and that is capable of separating from the first plate sufficiently to provide inter-plate capillary action;
- 30 wherein at least one of the first and second plates comprises a sheet-like material, and the at least one fluid transport element is bendable about an axis substantially parallel to the longitudinal axis of the fluid storage element, and the fluid transport element is attached to the withdrawal end of the fluid storage element.

4. A device according to claim 3, wherein the fluid transport element is attached to the base of the fluid storage element.
5. A device according to claim 3, wherein the fluid transport element comprises a nonwoven material.
6. An intravaginal device, said device comprising:
- a. a fluid storage element having a longitudinal axis, an insertion end, a withdrawal end, and at least one longitudinal side between the insertion and withdrawal ends; and
 - b. at least one fluid transport element being in fluid communication with the fluid storage element, the at least one fluid transport element comprising:
 - i. a first plate having an outwardly oriented surface and an inwardly oriented surface;
 - ii. a second plate coupled to the first plate; that has a first surface disposed and maintained in facing relationship with the inwardly oriented surface of the first plate and an opposite surface; and that is capable of separating from the first plate sufficiently to provide inter-plate capillary action; andwherein at least one of the first and second plates comprises a nonwoven material, and the at least one fluid transport element is bendable about an axis substantially parallel to the longitudinal axis of the fluid storage element, and the fluid transport element is attached on at least one longitudinal side of the fluid storage element.
7. A device according to claim 6, wherein the fluid transport element is attached at the withdrawal end of the fluid storage element.
8. An intravaginal device, said device comprising:

a. a fluid storage element having a longitudinal axis, an insertion end, a withdrawal end, and at least one longitudinal side between the insertion and withdrawal ends; and

b. at least one fluid transport element being in fluid communication with the fluid storage element, the at least one fluid transport element comprising:

i. a first plate having an outwardly oriented surface and an inwardly oriented surface;

ii. a second plate coupled to the first plate; that has a first surface disposed and maintained in facing relationship with the inwardly oriented surface of the first plate and an opposite surface; and that is capable of separating from the first plate sufficiently to provide inter-plate capillary action; and

wherein at least one of the first and second plates comprises a nonwoven material, and the at least one fluid transport element is bendable about an axis substantially parallel to the longitudinal axis of the fluid storage element, and fluid transport element is attached to itself proximate the withdrawal end of the fluid storage element.

9. A device according to claim 8, wherein the fluid transport element is attached at the withdrawal end of the fluid storage element.

10. An intravaginal device, said device comprising:

a. a fluid storage element having a longitudinal axis, an insertion end, a withdrawal end, and at least one longitudinal side between the insertion and withdrawal ends; and

b. at least one fluid transport element being in fluid communication with the fluid storage element, the at least one fluid transport element comprising:

i. a first plate having an outwardly oriented surface and an inwardly oriented surface;

5 ii. a second plate coupled to the first plate; that has a first surface disposed and maintained in facing relationship with the inwardly oriented surface of the first plate and an opposite surface; and that is capable of separating from the first plate sufficiently to provide inter-plate capillary action; and

10 wherein at least one of the first and second plates comprises a nonwoven material, and the at least one fluid transport element is bendable about an axis substantially parallel to the longitudinal axis of the fluid storage element, and wherein the fluid transport element is attached to the withdrawal string to substantially envelop the fluid storage element.

15 11. A device according to claim 10, wherein the fluid transport element is attached at the withdrawal end of the fluid storage element.

20 12. A fluid management device according to claim 1, said device substantially as herein described with reference to any one of the embodiments of the invention illustrated in the accompanying drawings and/or examples.

25 13. An intravaginal device according to any one of claims 3, 6, 8 or 10, said device substantially as herein described with reference to any one of the embodiments of the invention illustrated in the accompanying drawings and/or examples.

Dated this 30th day of June 2011

Shelston IP

Attorneys for: Johnson & Johnson Consumer Companies, Inc.

Fig. 1a

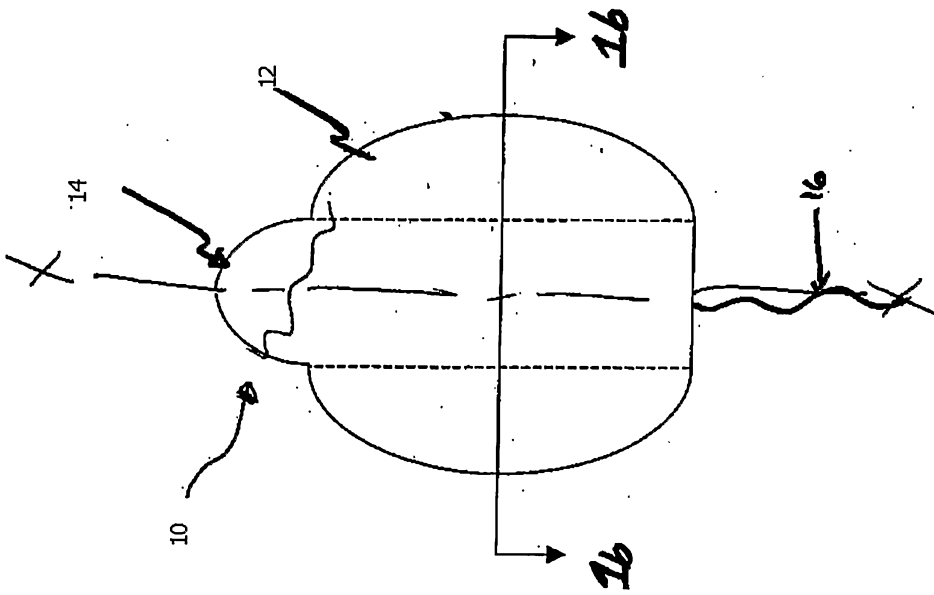

Fig. 1b

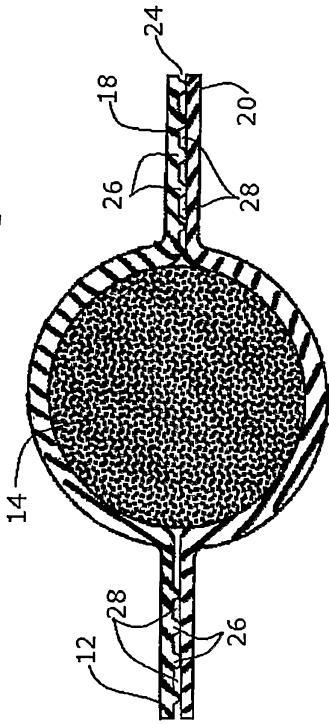

Fig. 1c

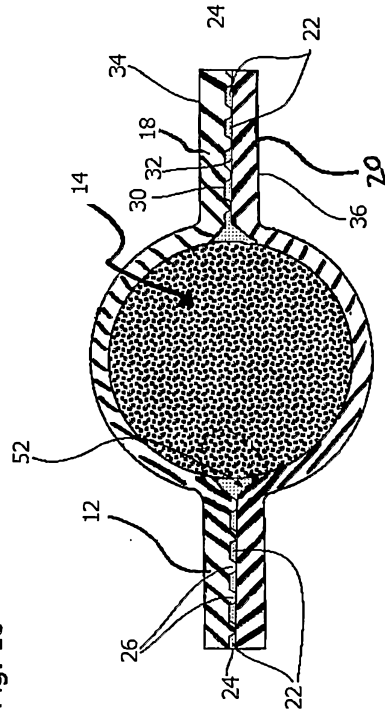

Fig. 2a

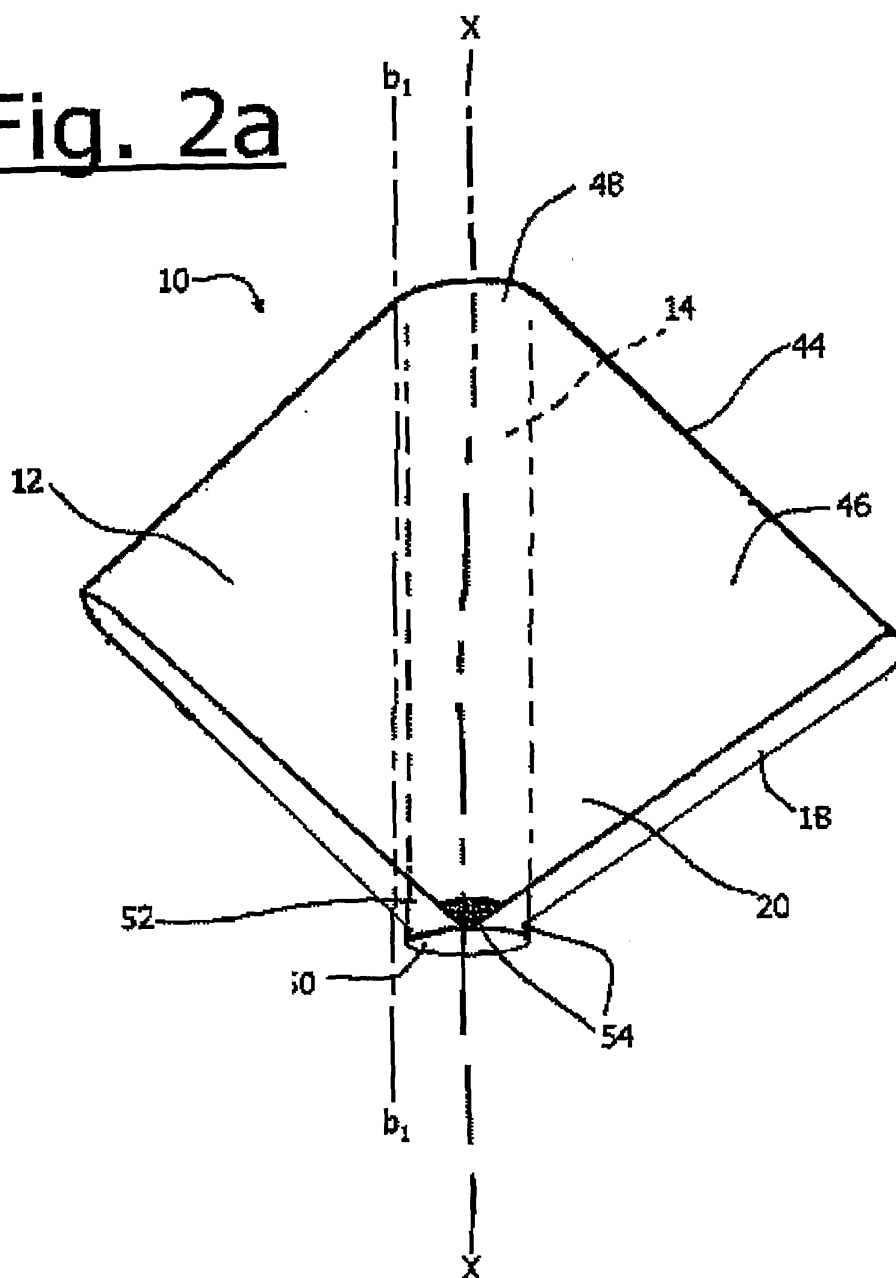

Fig. 2b

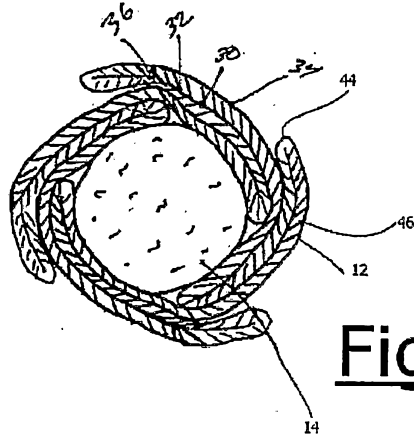
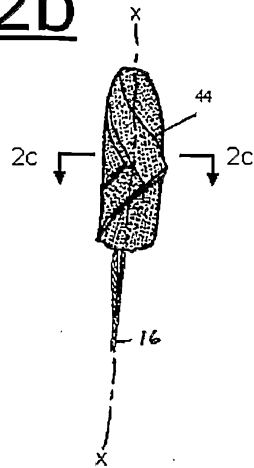

Fig. 2c

Fig. 2d

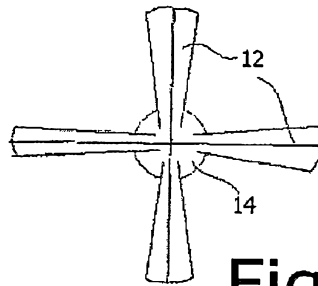
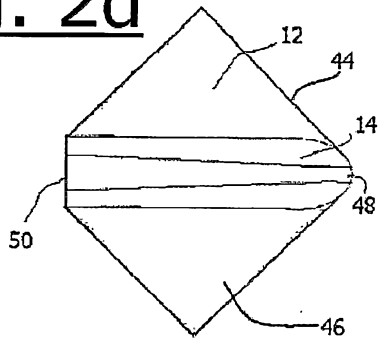

Fig. 2e

Fig. 3

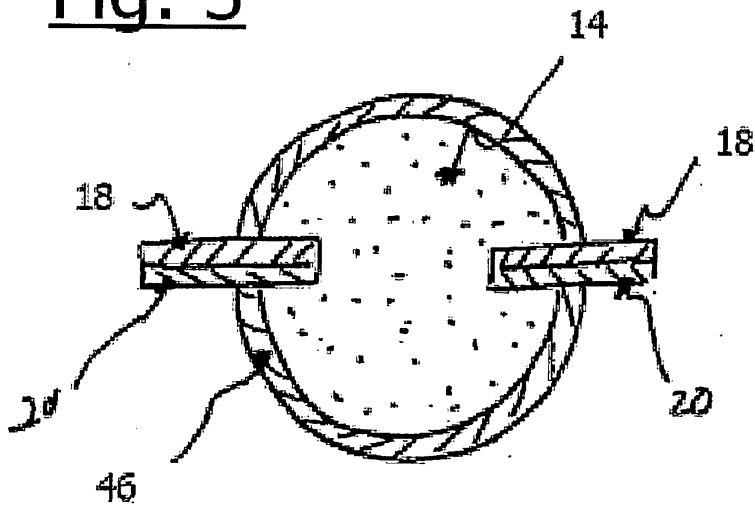

Fig. 4a

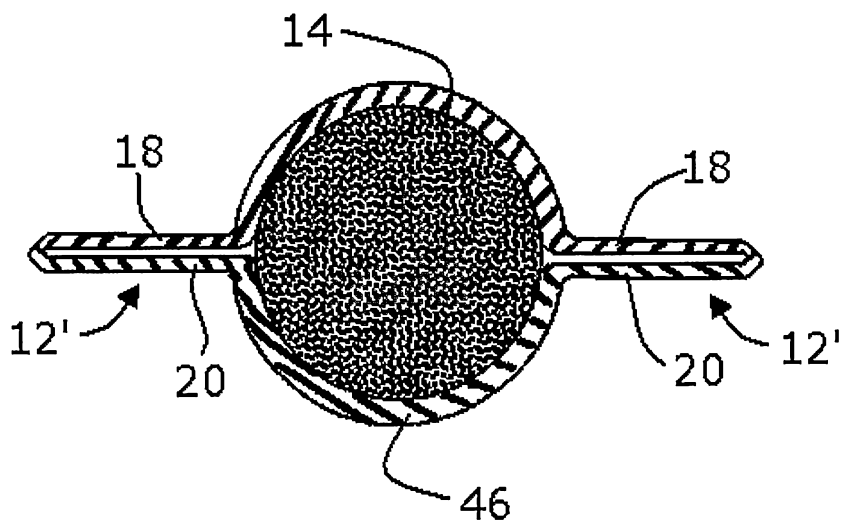
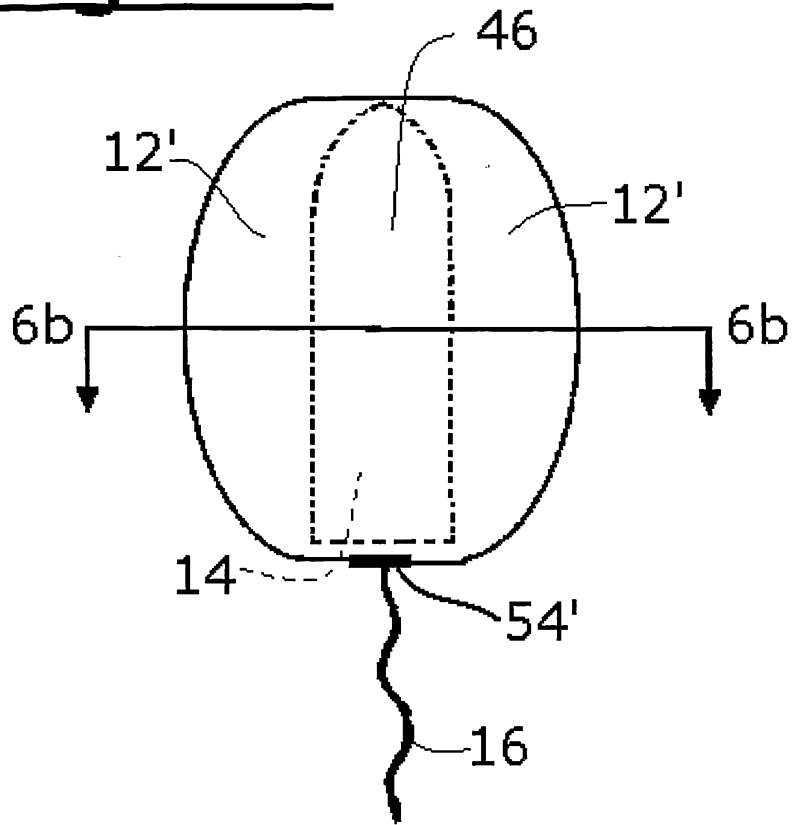

Fig. 4b

Fig. 5

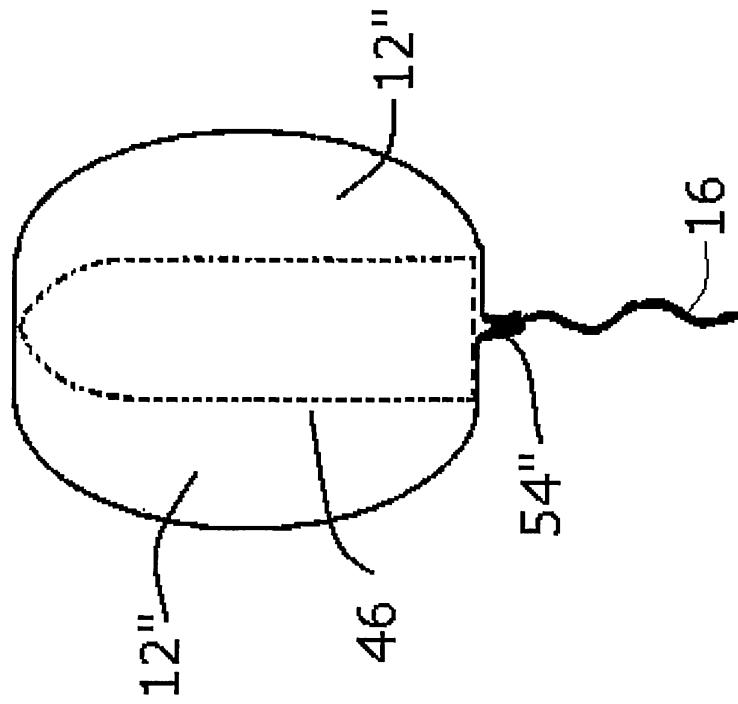

Fig. 6

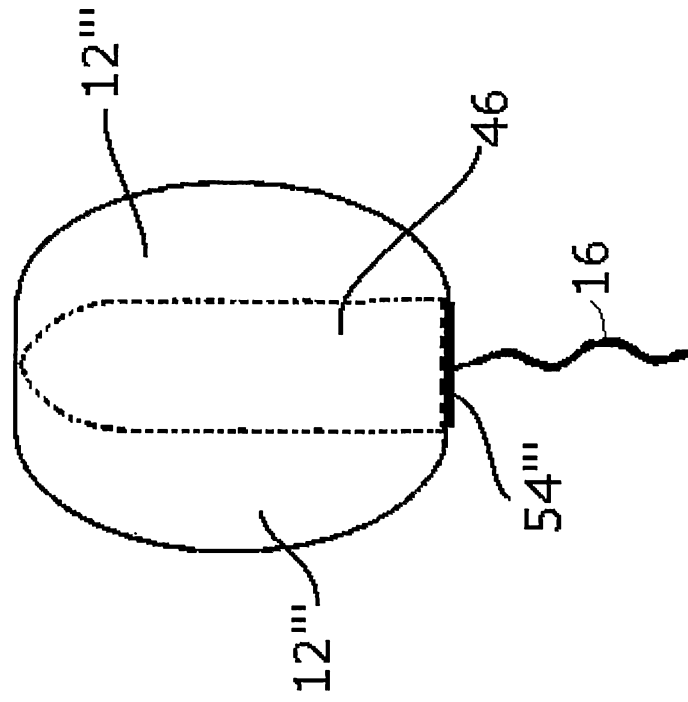

Fig. 7

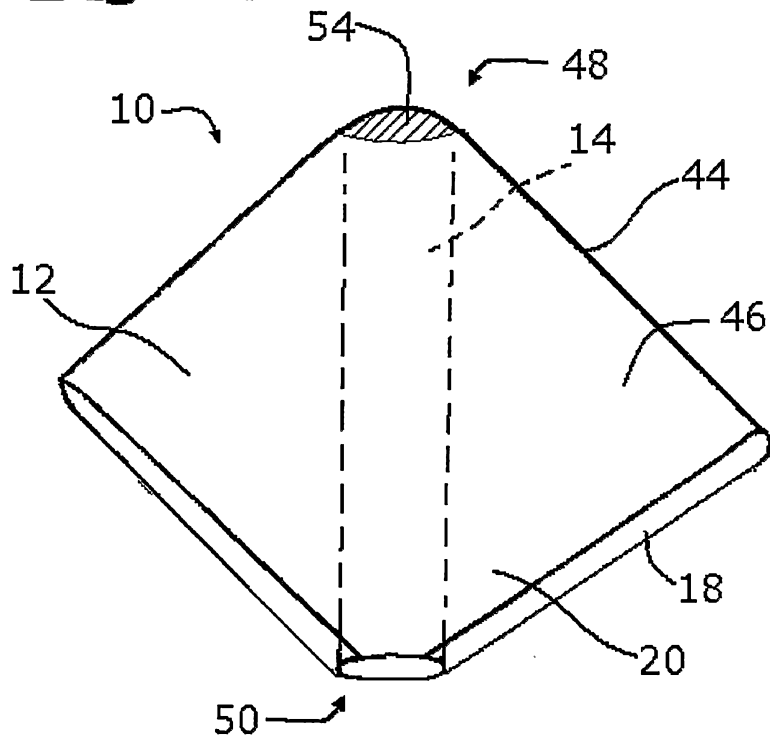

Fig. 8

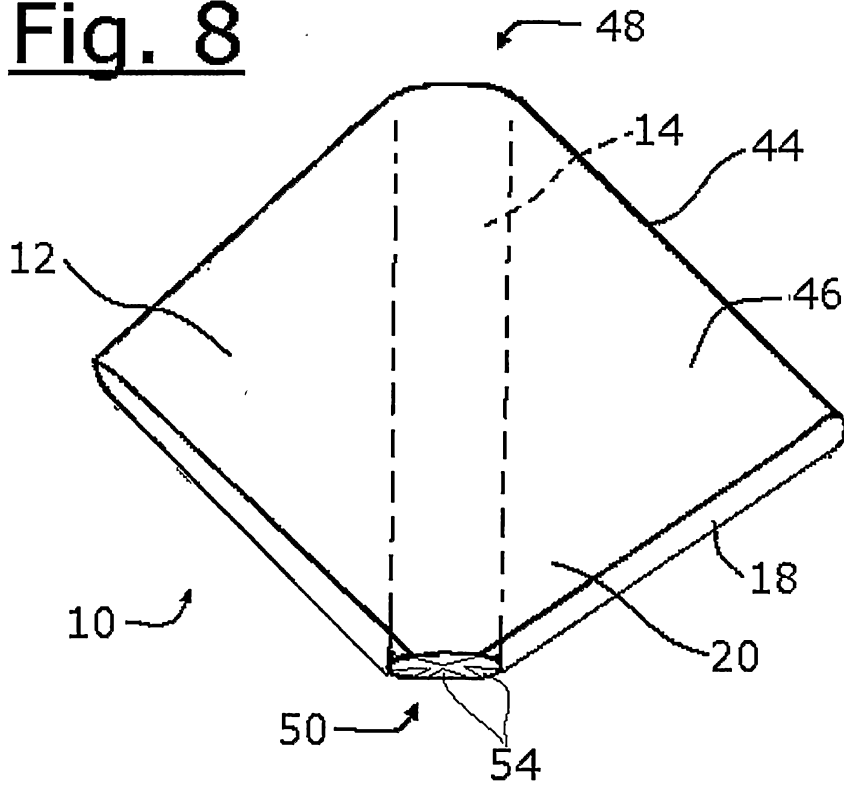

Fig. 10

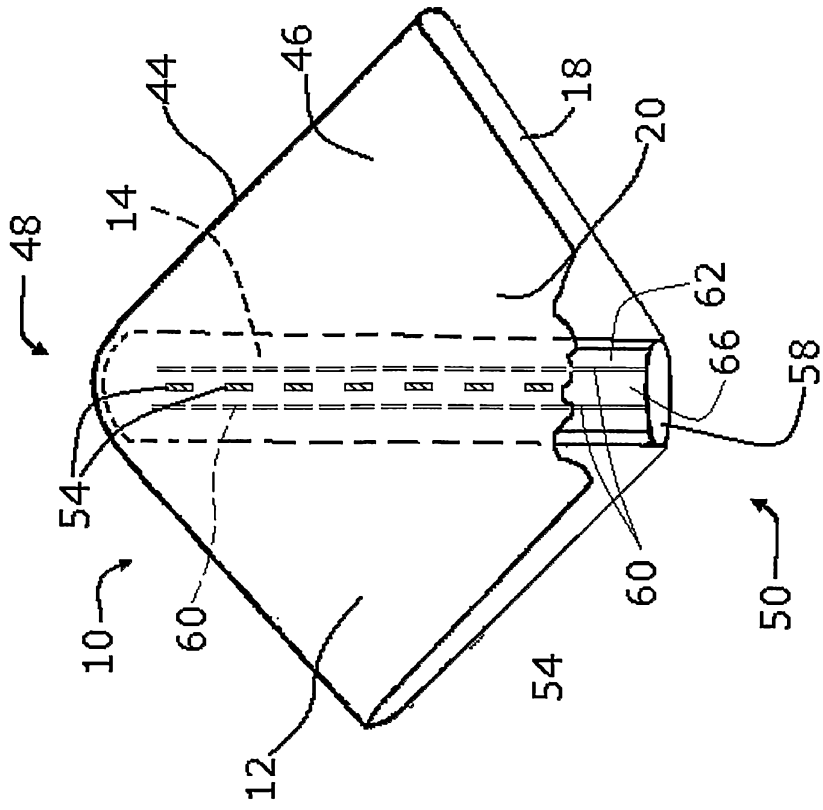
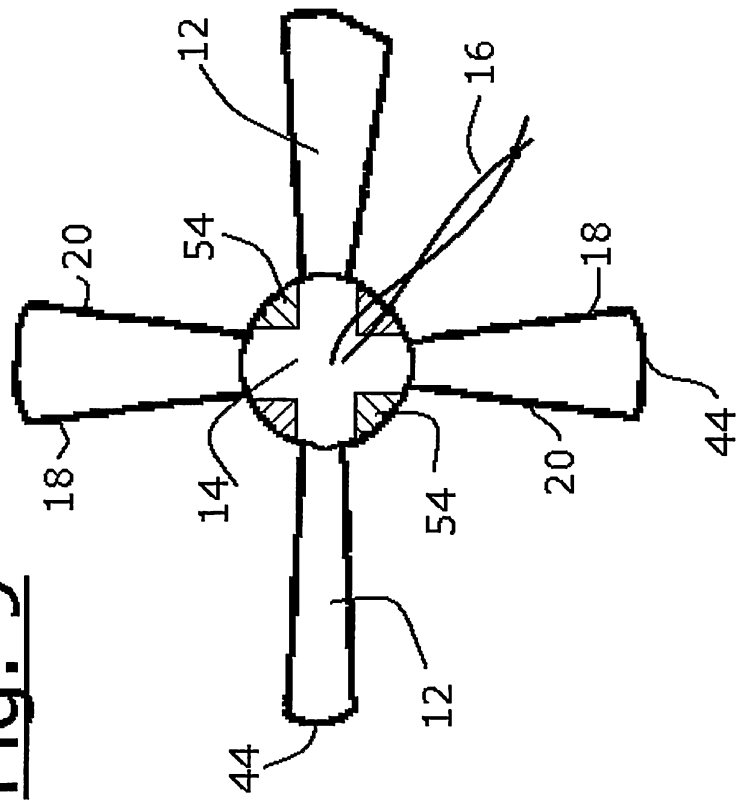
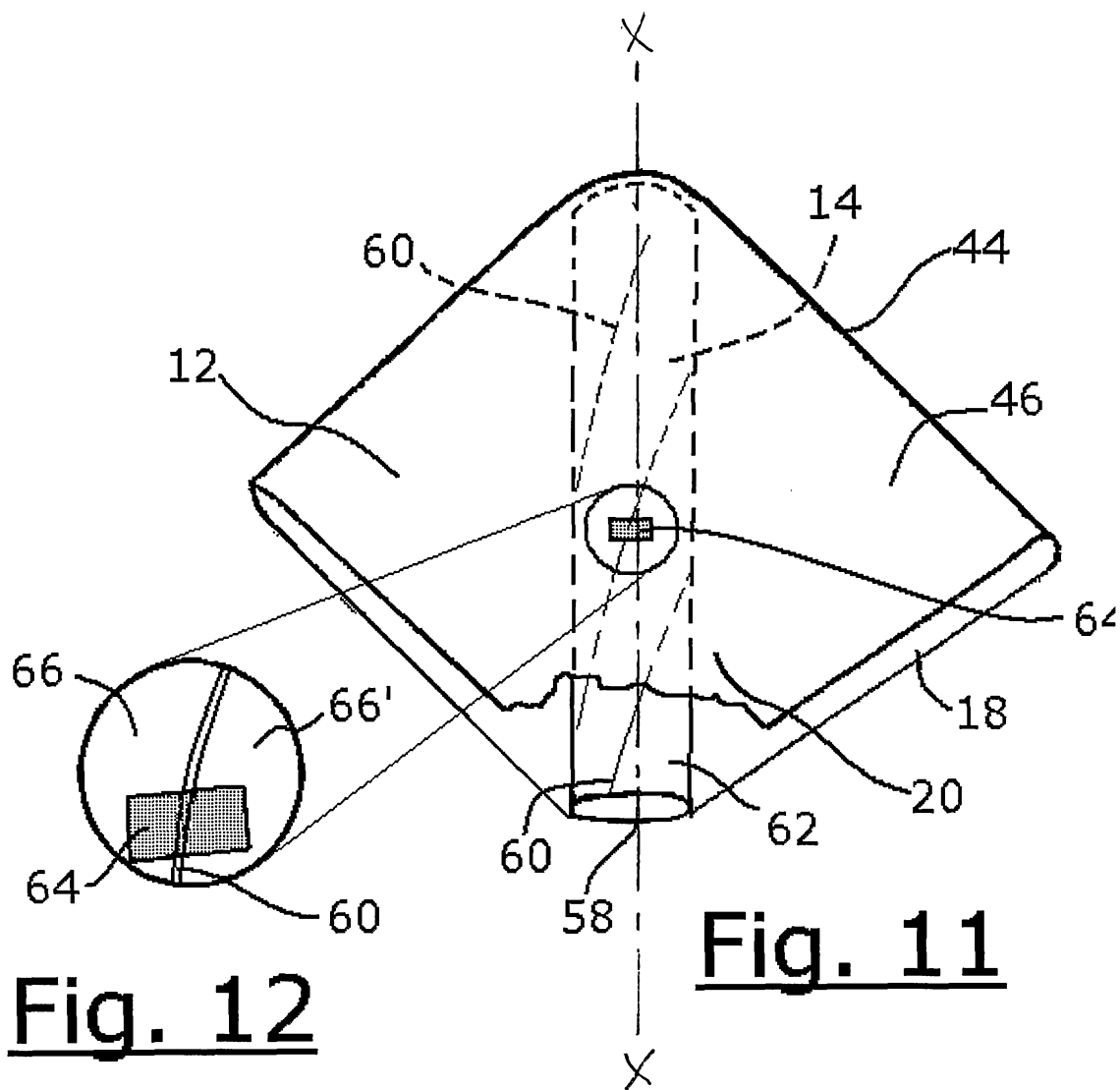

Fig. 9





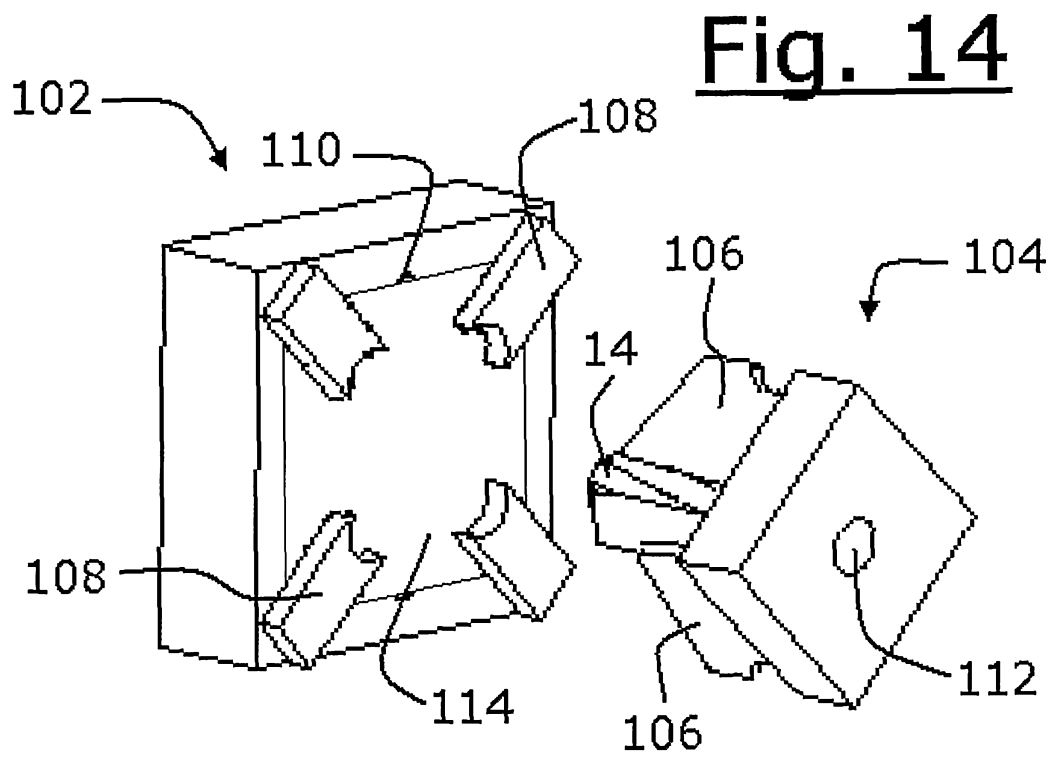
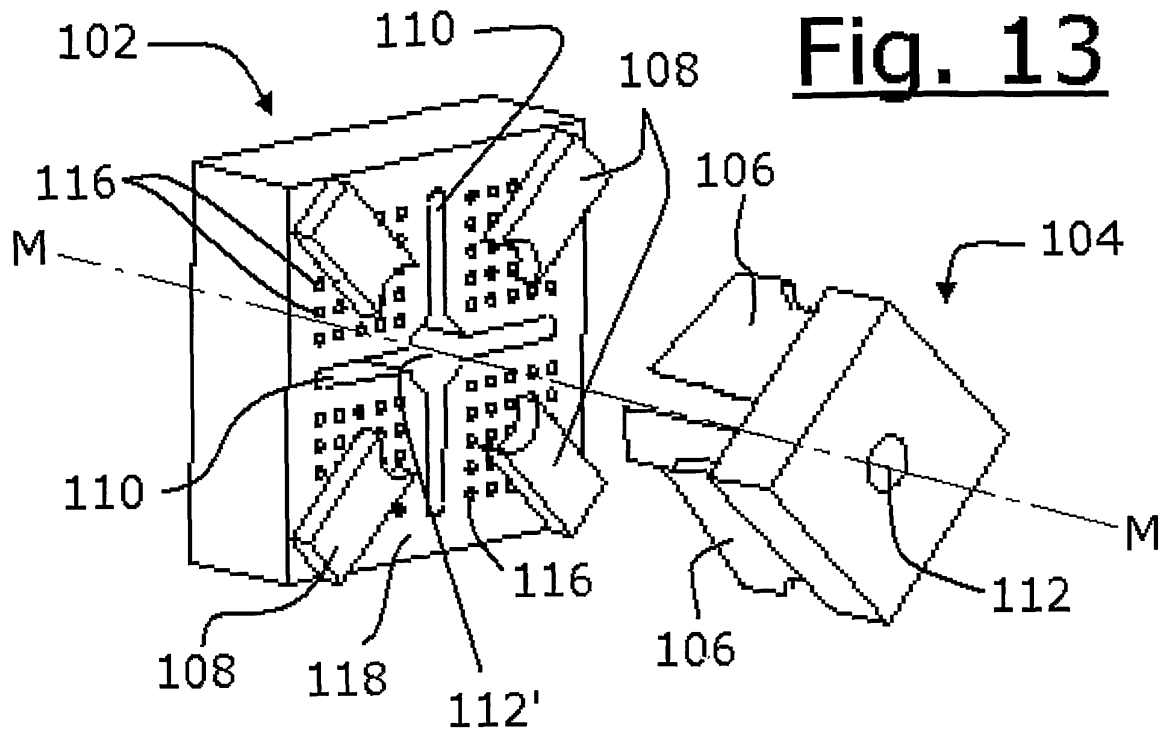

Fig. 16

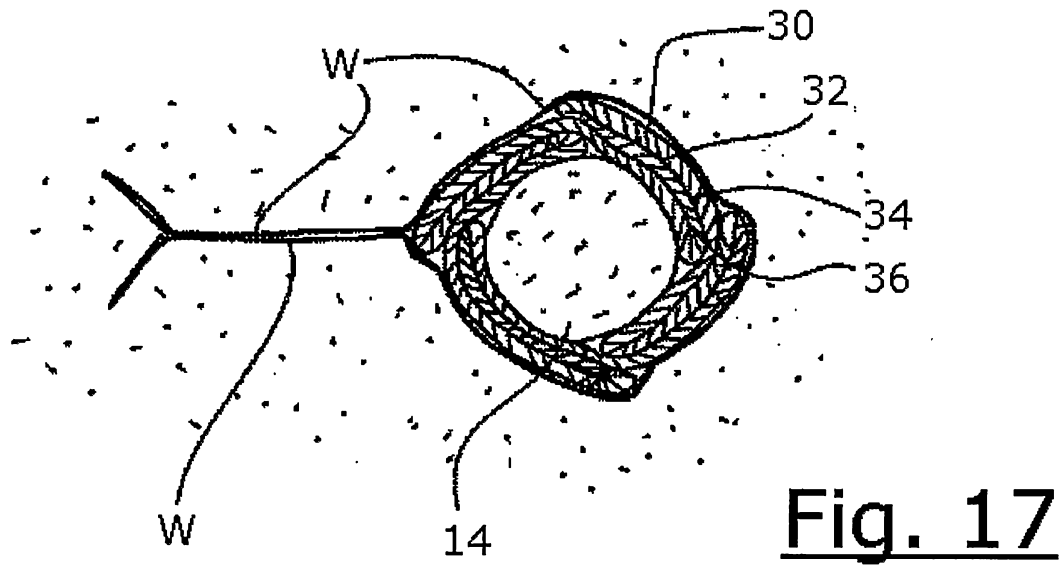
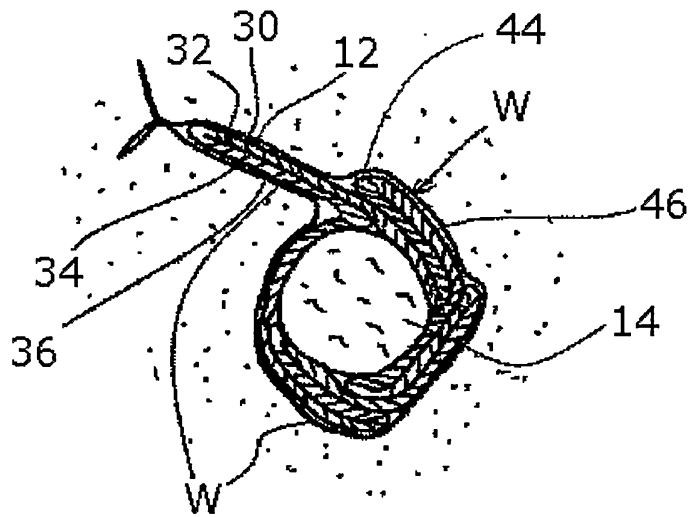

Fig. 17

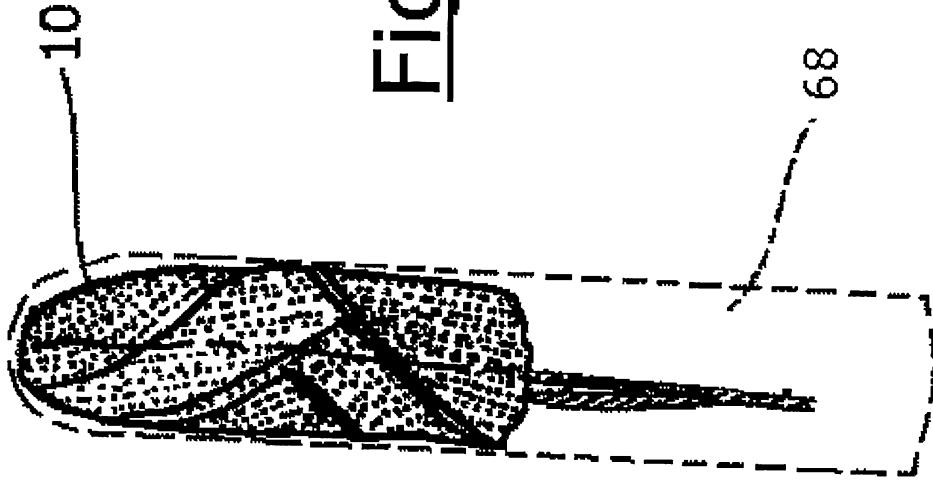

Fig. 18

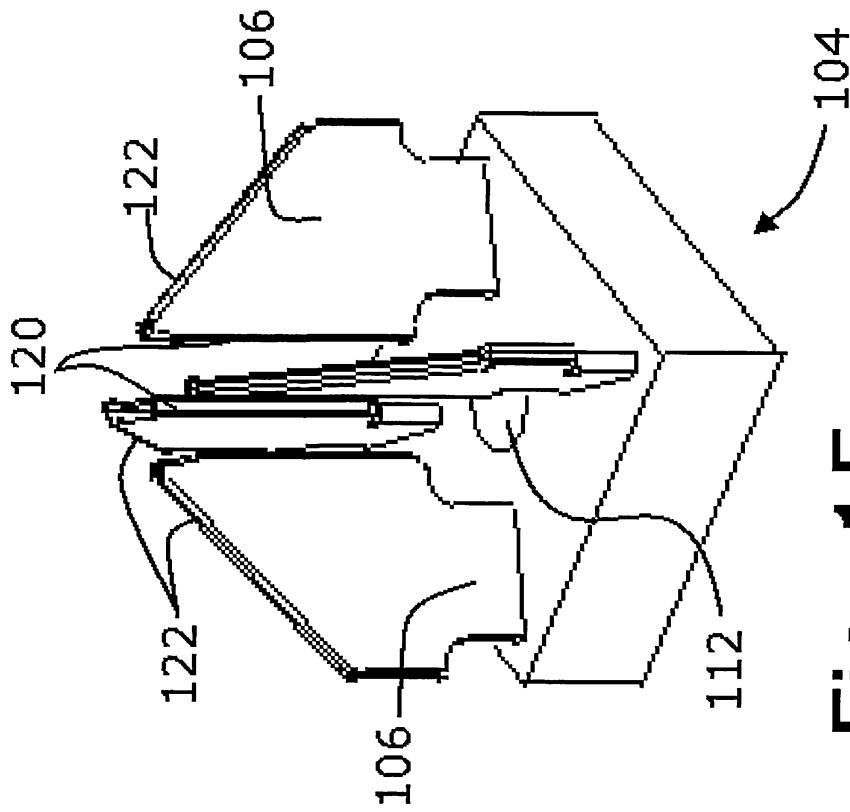

Fig. 15