

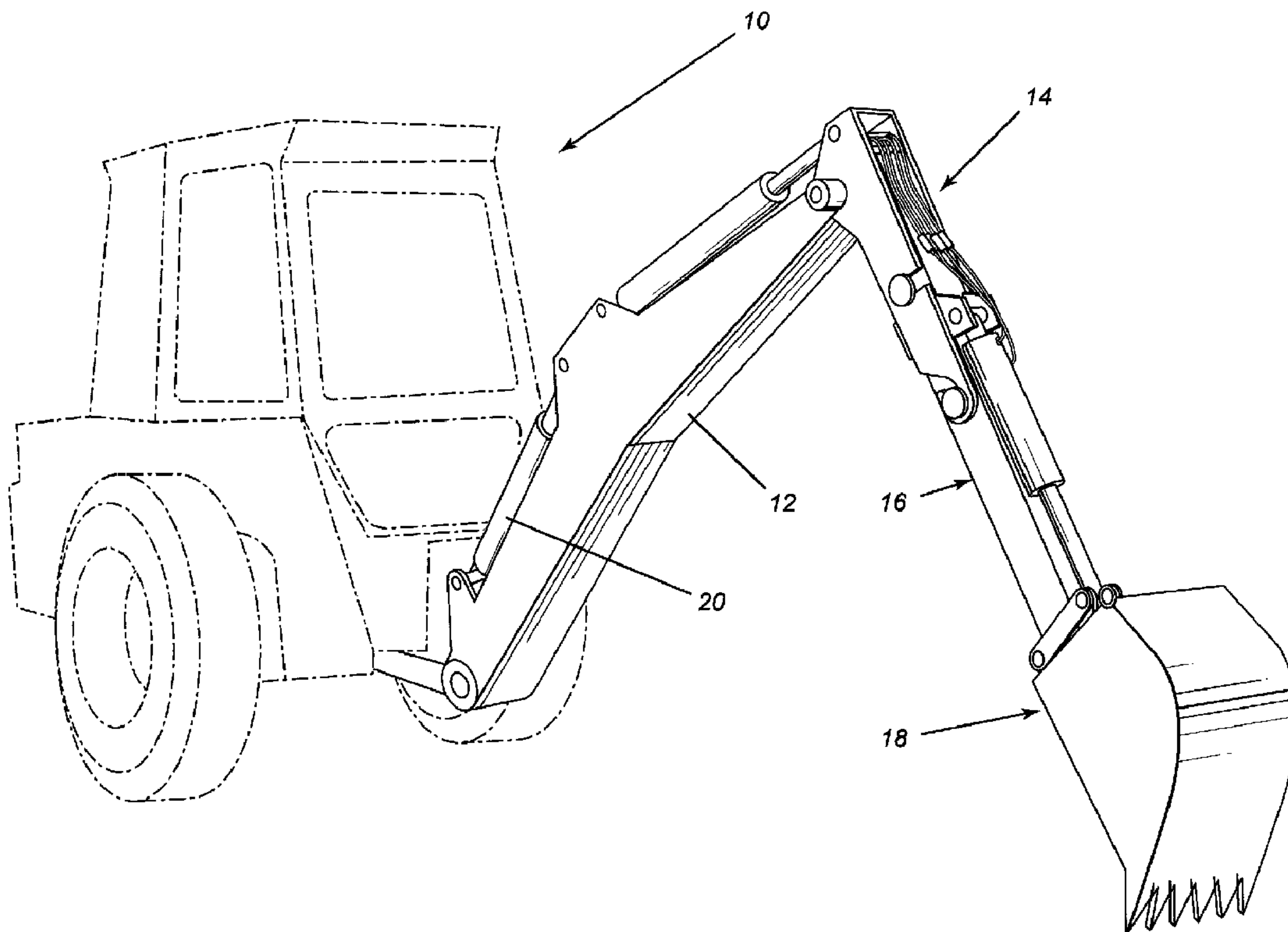

(22) Date de dépôt/Filing Date: 2006/05/13
 (41) Mise à la disp. pub./Open to Public Insp.: 2006/11/16
 (45) Date de délivrance/Issue Date: 2013/12/10
 (30) Priorité/Priority: 2005/05/16 (CAS.N. 2,507,393)

(51) Cl.Int./Int.Cl. *E02F 3/96* (2006.01)
 (72) Inventeur/Inventor:
 POIRE, DENIS, CA
 (73) Propriétaire/Owner:
 POIRE, DENIS, CA
 (74) Agent: FINCHAM, ERIC

(54) Titre : RACCORD RAPIDE
 (54) Title: QUICK ATTACH COUPLING DEVICE



(57) Abrégé/Abstract:

An assembly for securing an implement to a boom, the assembly comprising a boom having a boom proximal end and a boom distal end, a link member having a link proximal end and a link distal end, the link proximal end being pivotally connected to the



(57) **Abrégé(suite)/Abstract(continued):**

boom proximate the boom distal end, a first set of recesses formed in first and second sides of the link member, the first set of recesses being located intermediate the link member proximal end and the link member distal end, a second set of recesses being formed in the link member proximate the link member distal end, the second recesses each having an elongated configuration with a longitudinal axis extending parallel to a link member longitudinal axis, an opening to each of the second elongated recesses, the opening being at an end of a respective axis, the recesses being distant from the link member distal end, an implement assembly comprising a mounting arm and an implement, the mounting arm having a first end mounted to the implement, a pair of first pins extending outwardly from opposite sides of the mounting arm, and a pair of second pins extending outwardly from opposite sides of the mounting arm, the first pair of pins being located between an end opposite the implement receiving end and a center of gravity of the implement assembly.

A B S T R A C T

An assembly for securing an implement to a boom, the assembly comprising a boom having a boom proximal end and a boom distal end, a link member having a link proximal end and a link distal end, the link proximal end being pivotably connected to the boom proximate the boom distal end, a first set of recesses formed in first and second sides of the link member, the first set of recesses being located intermediate the link member proximal end and the link member distal end, a second set of recesses being formed in the link member proximate the link member distal end, the second recesses each having an elongated configuration with a longitudinal axis extending parallel to a link member longitudinal axis, an opening to each of the second elongated recesses, the opening being at an end of a respective axis, the recesses being distant from the link member distal end, an implement assembly comprising a mounting arm and an implement, the mounting arm having a first end mounted to the implement, a pair of first pins extending outwardly from opposite sides of the mounting arm, and a pair of second pins extending outwardly from opposite sides of the mounting arm, the first pair of pins being located between an end opposite the implement receiving end and a center of gravity of the implement assembly.

QUICK ATTACH COUPLING DEVICE

FIELD OF THE INVENTION

The present invention relates to a quick attach coupling device and more particularly, relates to a quick attach coupling device suitable for use with heavy equipment.

BACKGROUND OF THE INVENTION

Heavy equipment is typically used in various types of demolition and construction and loading; such equipment can include tractors, backhoes, excavators, loaders, and the like. Often, the heavy equipment is designed to be employed with different types of implements.

Typically, the piece of heavy equipment will include a boom extending from a portion thereof, the boom having a distal end at which end an arm is attached. The arm pivots relative to the boom and the distal end of the arm is normally designed to be secured to an implement. The implement can be any which is utilized such as a shovel, a bucket, grapples, magnets, etc. Normally, hydraulic cylinders are utilized for raising and lowering the boom and for moving the implement relative to the arm.

To most operators of such heavy equipment, it is most desirable that various implements be conveniently and reliably coupled to the arm. This then, allows a single piece of heavy equipment to be employed with any one of the implements and also allows for adjustment of the arm's length depending on the kind of implement used. Generally, the changing of an implement is a major task which is time consuming, difficult, and dangerous. The known arrangements are particularly a frustration for smaller pieces of heavy equipment which frequently have to change tasks during a single operating shift.

SUMMARY OF THE INVENTION

It is an object of the present invention to provide a coupling assembly for securing implements to a piece of heavy equipment allowing adjustment of the arm's length depending on the kind of implement used.

It is a further object of the present invention to provide a method for quickly changing implements on heavy equipment having a boom, in order to make it more versatile.

According to one aspect of the present invention, there is provided an assembly for securing an implement, the assembly comprising a boom having a boom proximal end and a boom distal end, a link member having a link proximal end and a link distal end, the link proximal end being pivotably connected to the boom proximate the boom distal end, a first recess formed in a first side of the arm, the recess being located intermediate the arm proximal end and the arm distal end, a second recess being formed in the link member proximate the link member distal end, the second recess having an elongated configuration with a longitudinal axis extending parallel to a link member longitudinal axis, an opening to the second elongated recess, the opening being at an end of the recess distant from the link member distal end, an implement assembly comprising a mounting arm and an implement, the mounting arm having a first end mounted to the implement, a pair of first pins extending outwardly from opposite sides of the mounting arm, and a pair of second pins extending outwardly from opposite sides of the mounting arm, the first pair of pins being located between the implement receiving end and a center of gravity of the implement assembly.

In a further aspect of the present invention, there is provided a method for securing an implement to a vehicle having a boom comprising the step of supplying an assembly for securing an implement, the assembly comprising the assembly of Claim 1 further including

locking means for securing at least one of the pair of pins within a respective recess, a link member having a link proximal end and a link distal end, the link proximal end being pivotably connected to the arm proximate the arm distal end, a first recess formed in a first side of the arm, the recess being located intermediate the arm proximal end and the arm distal end, a second recess being formed in the link member proximate the link member distal end, the second recess having an elongated configuration with a longitudinal axis extending parallel to a link member longitudinal axis, an opening to the second elongated recess, the opening being at an end of the recess distant from the link member distal end, an implement assembly comprising a mounting arm, the mounting arm having a mounting arm distal end mounted to an implement, a pair of first pins extending outwardly from opposite sides of the mounting arm, and a second set of pins extending outwardly from opposite sides of the mounting arm, the first set of pins being located between the implement receiving end and a center of gravity of the implement assembly, placing the implement assembly on a substrate, manipulating the link member such that the second set of pins enters the second oblong recess, raising the arm while maintaining the link member in a vertical position whereby the first set of pins will enter the first recess, and locking the first set of pins in position while in the first recess.

As used herein, the term "heavy equipment" is not tended to limit the type of vehicle or machine with which the present invention can be used. Rather, it is inclusive of all types of construction, demolition and loading equipment in which an implement situated at the end of a boom is utilized.

The assembly of the present invention comprises a link member and an implement assembly which includes a mounting arm. The mounting arm carries first and second sets of

pins which are designed to fit into the first and second recesses of the link member.

When assembled, various means are provided for locking the mounting arm and link member in position. Such means can be either automatic or manual.

BRIEF DESCRIPTION OF THE DRAWINGS

Having thus generally described the invention, reference will be made to the accompanying drawings illustrating an embodiment thereof, in which:

Figure 1 is a perspective view of a piece of heavy equipment utilizing the quick connect/disconnect assembly of the present invention;

Figure 2 is a perspective exploded view of a pair of implement assemblies which may be used with the present invention;

Figures 3A, 3B, 3C and 3D illustrate the sequence of operation for connecting the implement assembly to the link member;

Figure 4 is a partial cross section view illustrating locking of the implement assembly in place; and

Figures 5A, 5B and 5C illustrate alternative locking arrangements.

DETAILED DESCRIPTION OF THE INVENTION

Referring to the drawings in greater detail and by reference characters thereto, there is illustrated in Figure 1 a heavy equipment vehicle which, in the illustrated embodiment, comprises a tractor generally designated by reference numeral 10.

Tractor 10 has a boom 12 secured thereto in a conventional manner. The other major components include a link member 14, a mounting arm 16, and a shovel 18 which is one of the implements which may be used. Together, mounting arm 16 and shovel 18 constitute an implement assembly.

As is known in the art, a hydraulic cylinder 20 is utilized for raising and lowering boom 12 which is pivotably connected at its proximal end to tractor 10.

At boom distal end 22, boom 12 is connected to link member 14 at link member proximal end 24. Link member 14 is pivotably connected at boom distal end 22. A hydraulic cylinder 28 extends between a mid point on boom 12 and link member 14 at link member proximal 24.

Link member 14 includes a first U-shaped recess 30 formed at one side of link member 14. At link member distal end 26, there is provided a further U-shaped elongated recess 32 which has an entry 34 on the side of link member 14 opposed to that in which U-shaped recess 30 is formed. Mounting arm 16 of the implement assembly has a mounting arm proximal end 38 and a mounting arm distal end 40. A hydraulic cylinder is mounted on mounting arm 16 and connected to shovel 18 to permit manipulation thereof.

Mounting arm 16 also includes a first set of pins 44 extending outwardly from first and second side walls and second set of pins 46 which also extend outwardly from the side walls, but closer to said mounting arm proximal end 38.

As shown in Figure 2, a different implement comprising a grapple 48 is also provided with a mounting arm 50 of a configuration similar to mounting arm 16. Thus, there are provided a first set of pins 52 and a second set of pins 54.

Referring to Figures 3A to 3D, the installation procedure is illustrated. As shown by the arrows, cylinder 28 is operated so as to move link member 14 into a position whereby first set of pins 52 enter entry 34 to U-shaped recess 32. Boom 12 is then lifted to cause pins 54 to enter recess 30. Subsequently, a bolt 58 and a plate 60 may be attached to secure mounting arm 16 into position.

Figures 5A, 5B and 5C illustrate alternate means of securing link member 14 with mounting arm 16. The arrangement illustrated in Figure 5A illustrates a bolt 58 passing through mounting arm 16 to secure the same.

In Figure 5B, a member 333 forming a portion of mounting arm 16 extends through an opening in link member 14. A bolt 111 extends through a threaded member 222 to retain the same in position.

In Figure 5C, a cylinder 111' is activated to place member 222' within the recess of portion 333.

The embodiments of an invention in which an exclusive property or privilege is defined as follows:

1. An assembly for securing an implement, said assembly comprising:
 - a boom having a boom proximal end and a boom distal end;
 - a link member having a link proximal end and a link distal end, said link proximal end being pivotably connected to said boom proximate said boom distal end;
 - a first set of recesses formed in first and second sides of said link member, said first set of recesses being located intermediate said link member proximal end and said link member distal end, a second set of recesses being formed in said link member proximate said link member distal end, said second recesses each having an elongated configuration with a longitudinal axis extending parallel to a link member longitudinal axis, an opening to each of said second elongated recesses, said opening being at an end of a respective axis, said recesses being distant from said link member distal end;
 - an implement assembly comprising a mounting arm and an implement, said mounting arm having a first end mounted to said implement, a pair of first pins extending outwardly from opposite sides of said mounting arm, and a pair of second pins extending outwardly from opposite sides of said mounting arm, said first pair of pins being located between an end opposite said implement receiving end and a center of gravity of said implement assembly.
2. The assembly of Claim 1 further including at least one cylinder extending between said boom and said link member.
3. The assembly of Claim 1 further including means for locking said mounting arm to said link member.

4. The assembly of Claim 3 wherein said means for locking comprises a bolt arrangement.
5. The assembly of Claim 3 wherein said boom includes a boom hydraulic cylinder for lifting and lowering said boom.
6. The assembly of Claim 3 further including a mounting arm hydraulic cylinder mounted on said mounting arm for operating an implement.
7. The assembly of Claim 3 wherein said base member comprises a base wall and first and second side walls to thereby define a channel therein, said mounting arm fitting within said channel.
8. A method for securing an implement to a vehicle having a boom comprising the step of supplying an assembly for securing an implement, said assembly comprising:
 - a boom having a boom proximal end and a boom distal end;
 - a link member having a link proximal end and a link distal end, said link proximal end being pivotably connected to said boom proximate said boom distal end;
 - a first set of recesses formed in first and second sides of said link member, said first set of recesses being located intermediate said link member proximal end and said link member distal end, a second set of recesses being formed in said link member proximate said link member distal end, said second recesses each having an elongated configuration with a longitudinal axis extending parallel to a link member longitudinal axis, an opening to each of said second elongated recesses, said opening being at an end of a respective axis, said recesses being distant from said link member distal end;
 - an implement assembly comprising a mounting arm and an implement, said mounting arm having a first end mounted to said implement, a pair of first pins extending

outwardly from opposite sides of said mounting arm, and a pair of second pins extending outwardly from opposite sides of said mounting arm, said first pair of pins being located between an end opposite said implement receiving end and a center of gravity of said implement assembly;

placing said implement assembly on a substrate;

manipulating said link member such that said first set of pins enters said second oblong recess;

raising said arm while maintaining said link member in a vertical position whereby said second set of pins will enter said first recess; and

locking said second set of pins in said first recess.

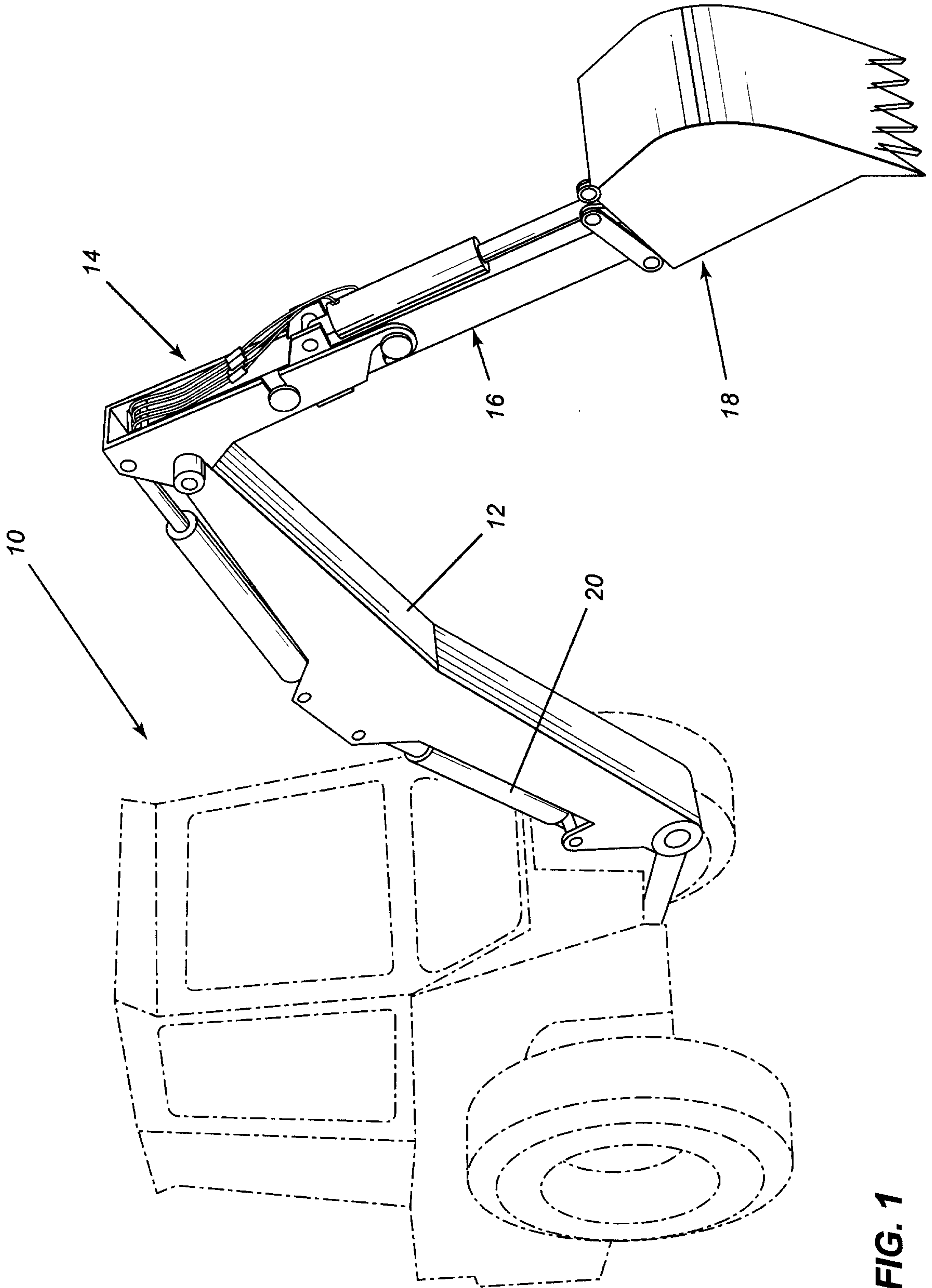

FIG. 1

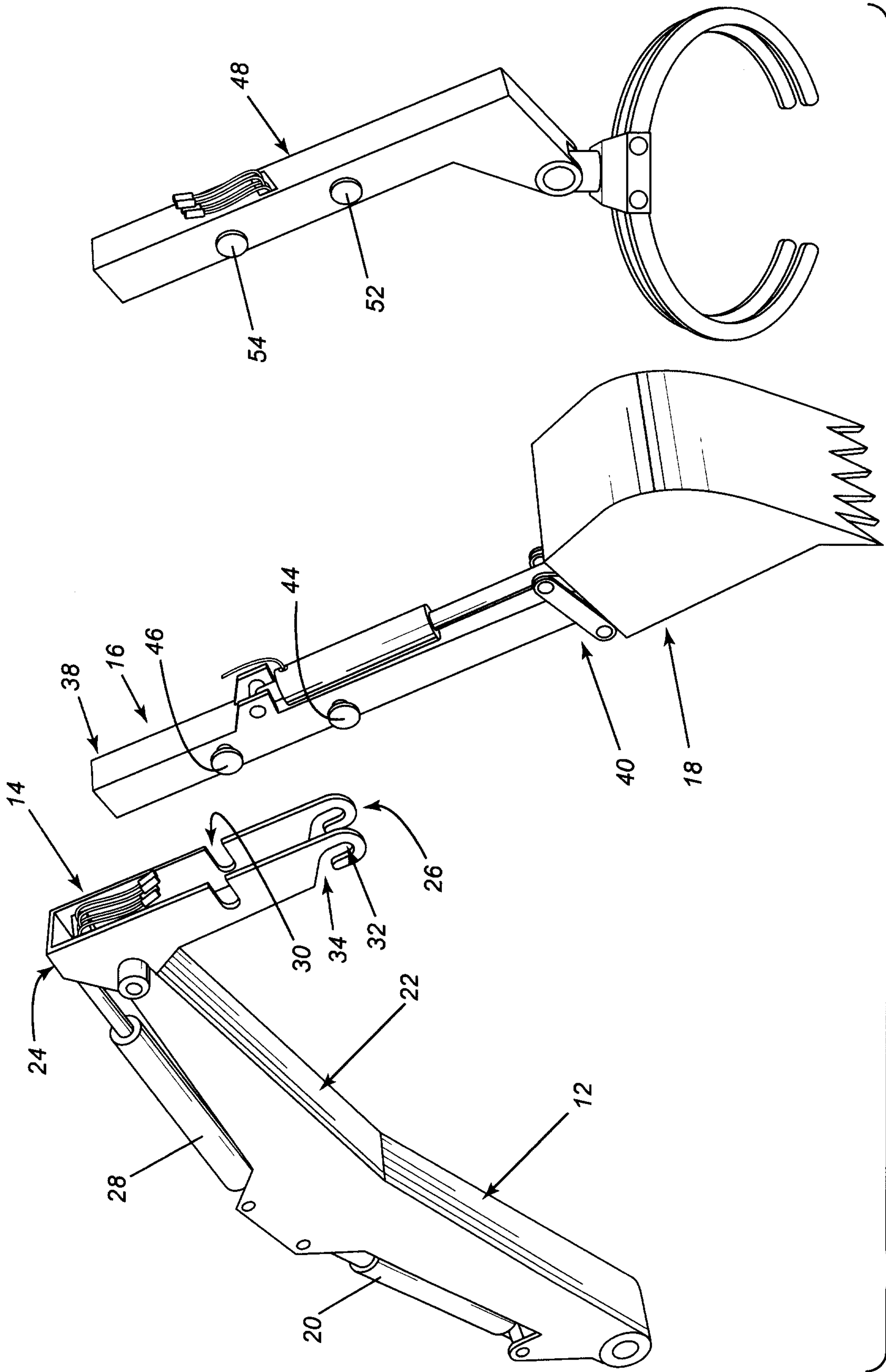

FIG. 2

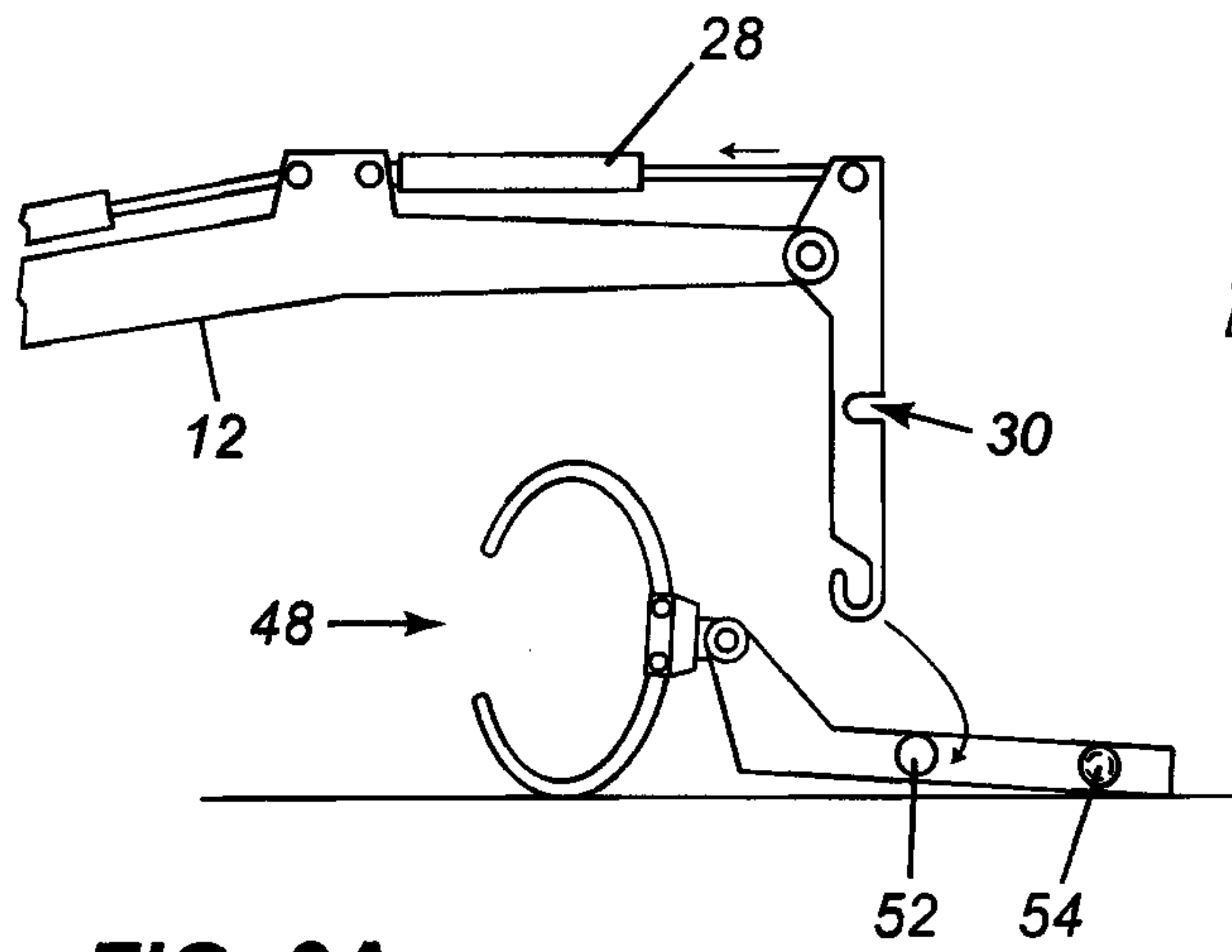

FIG. 3A

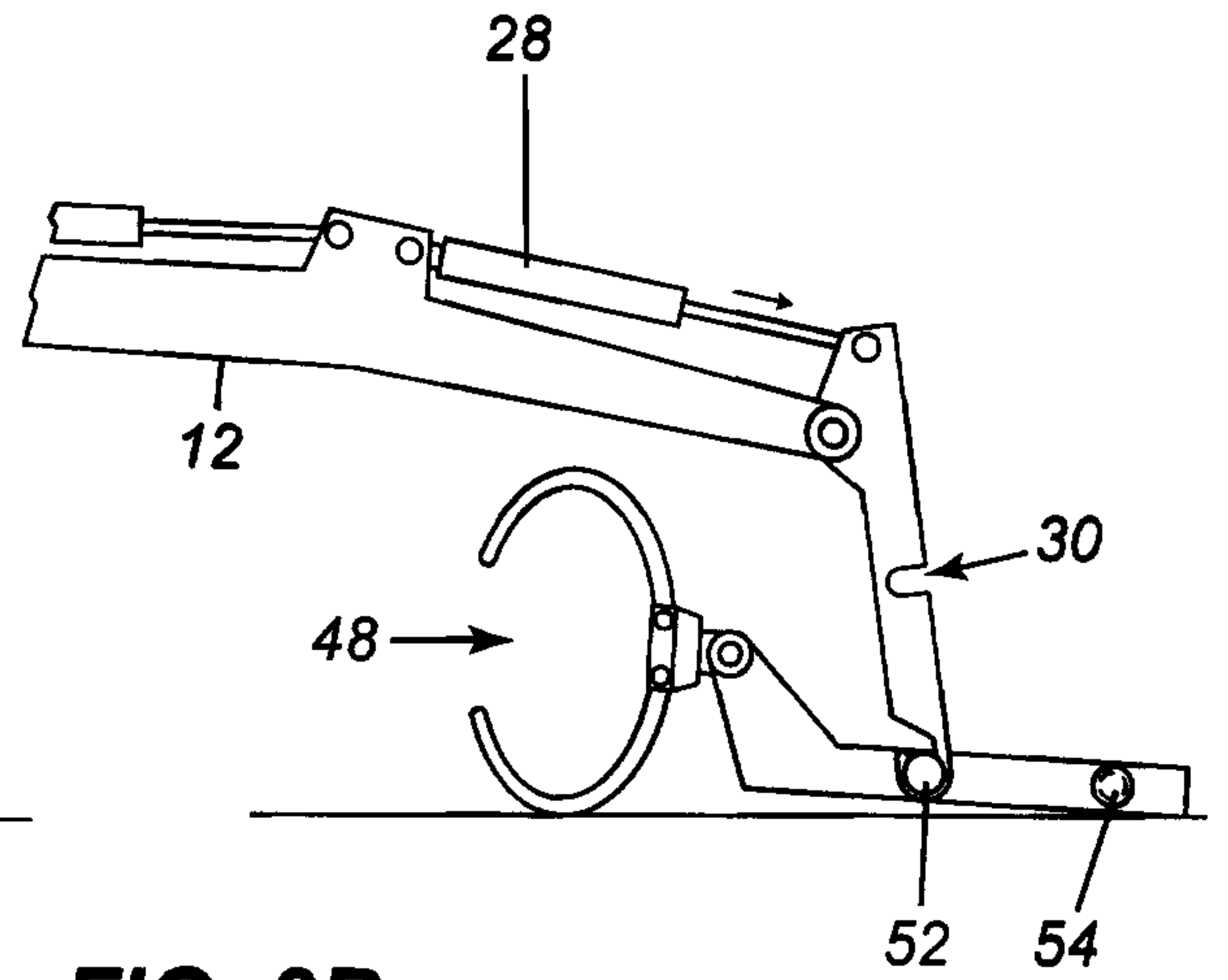

FIG. 3B

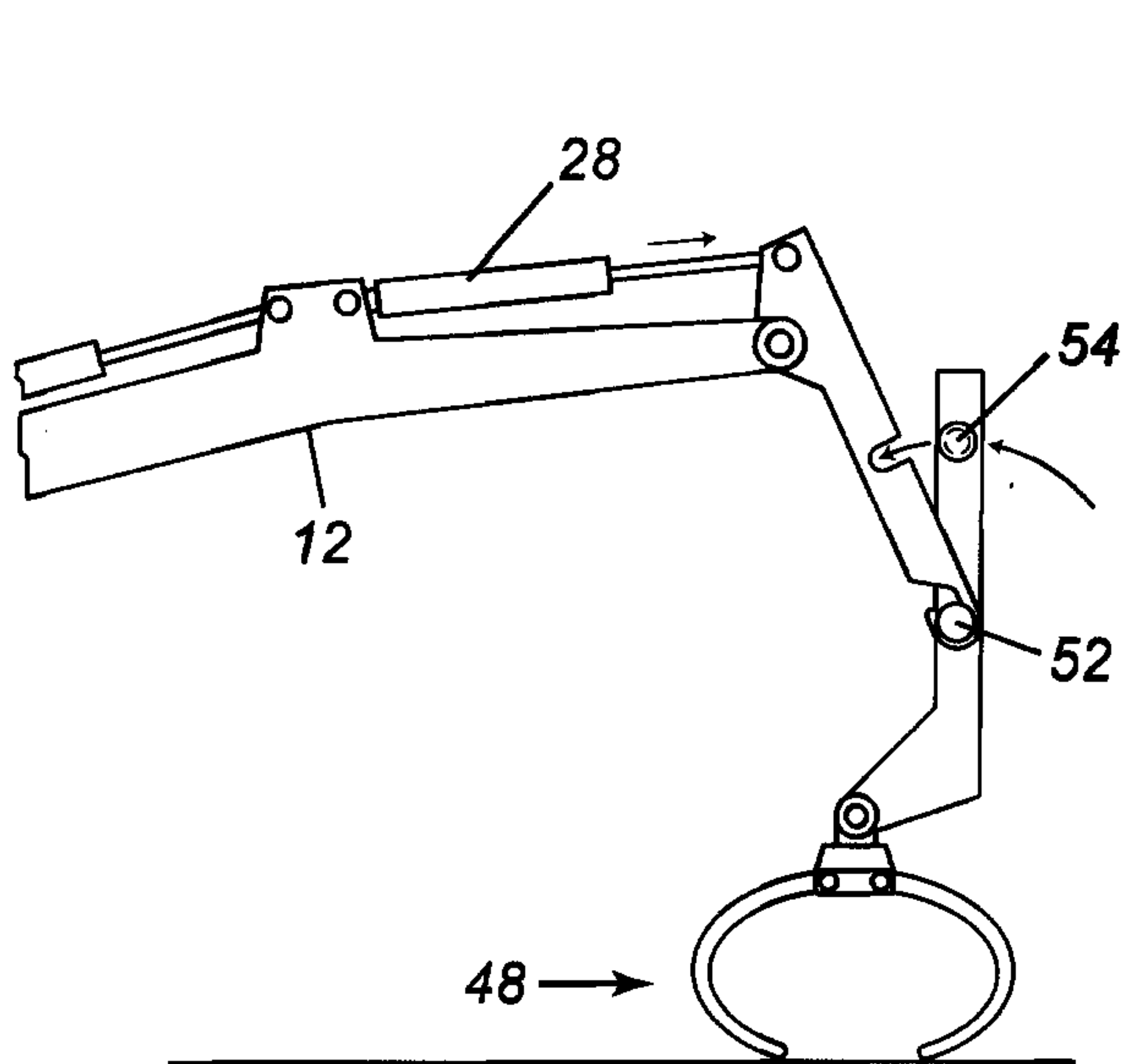

FIG. 3C

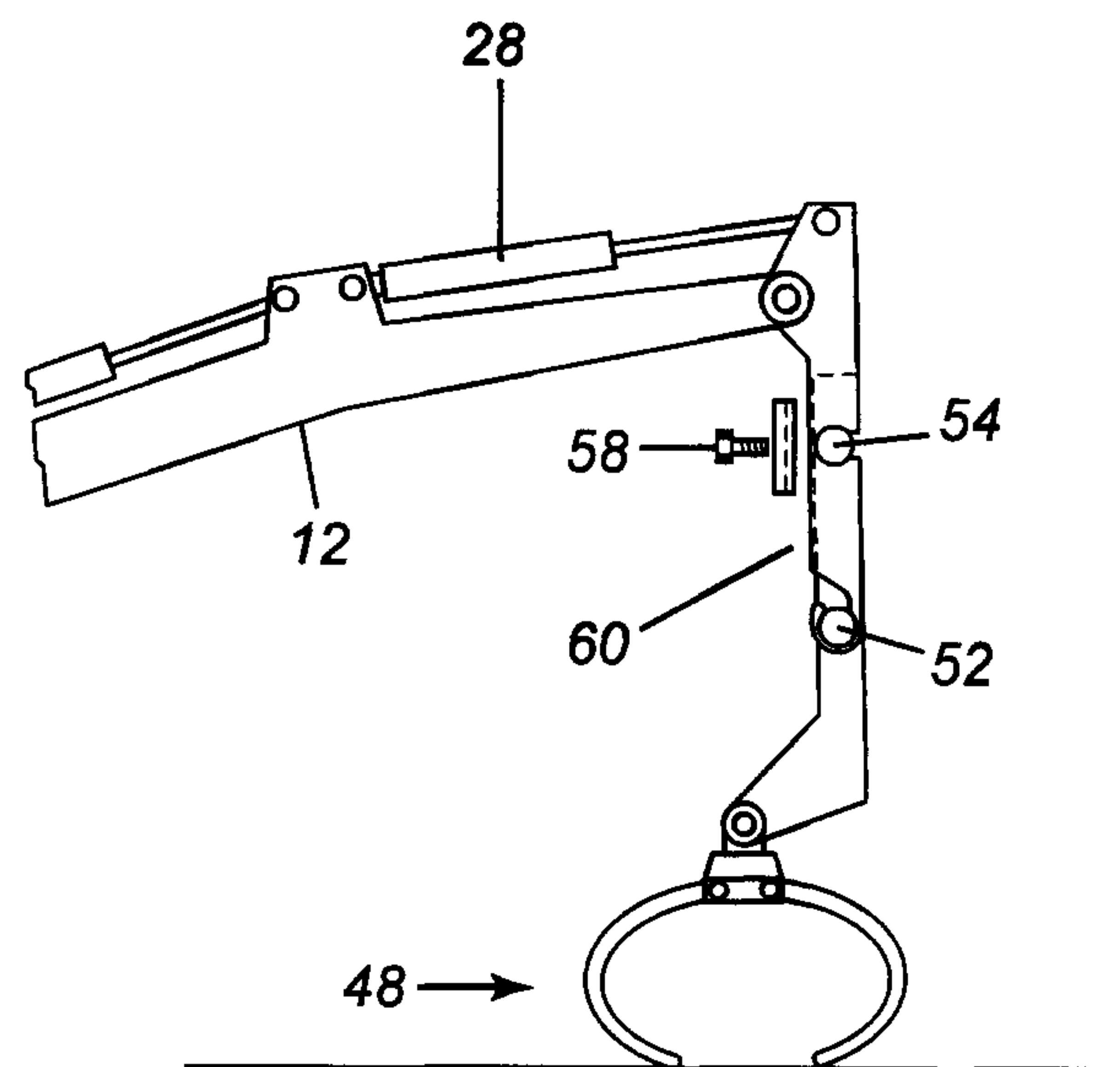

FIG. 3D

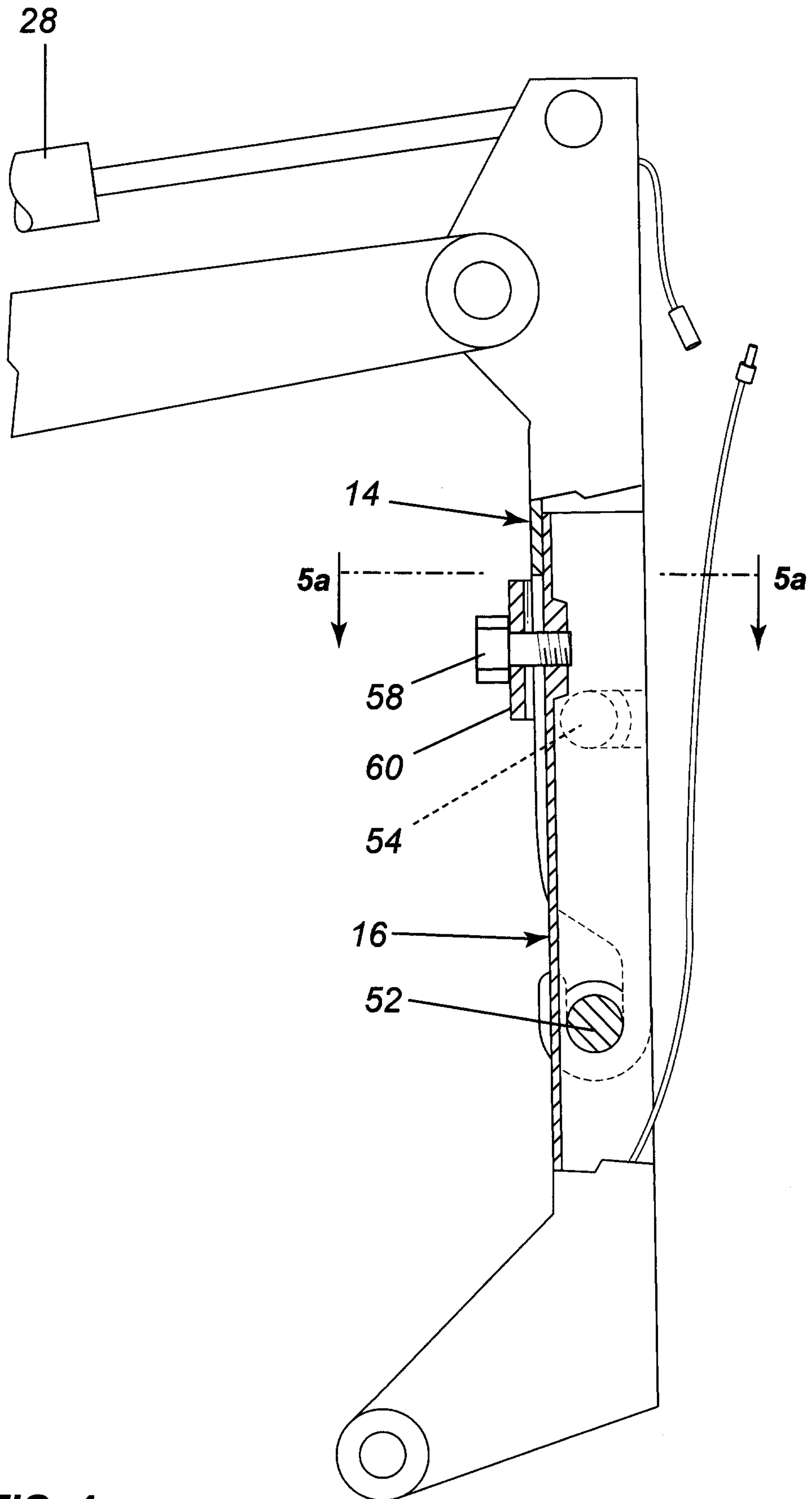

FIG. 4

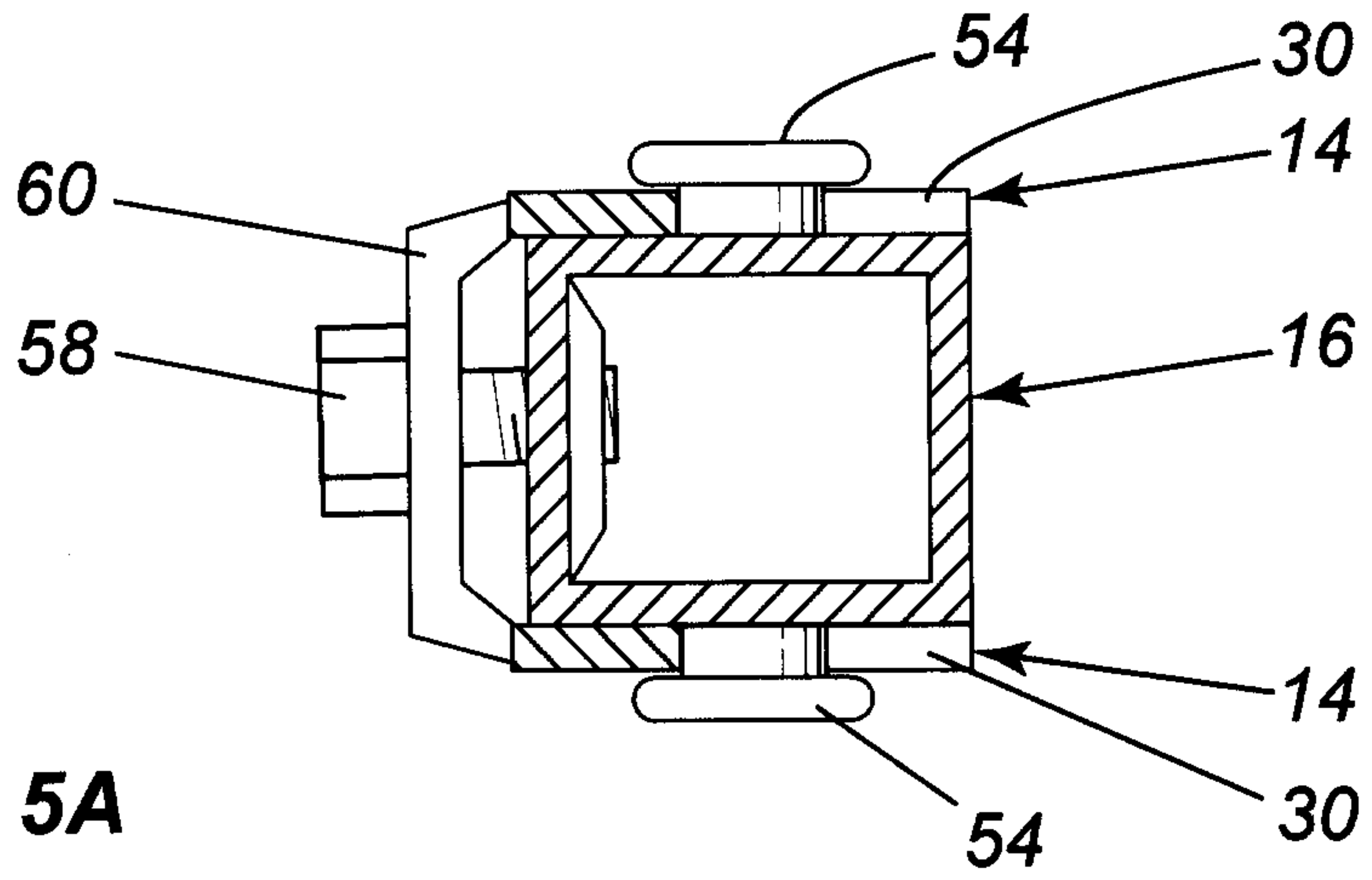

FIG. 5A

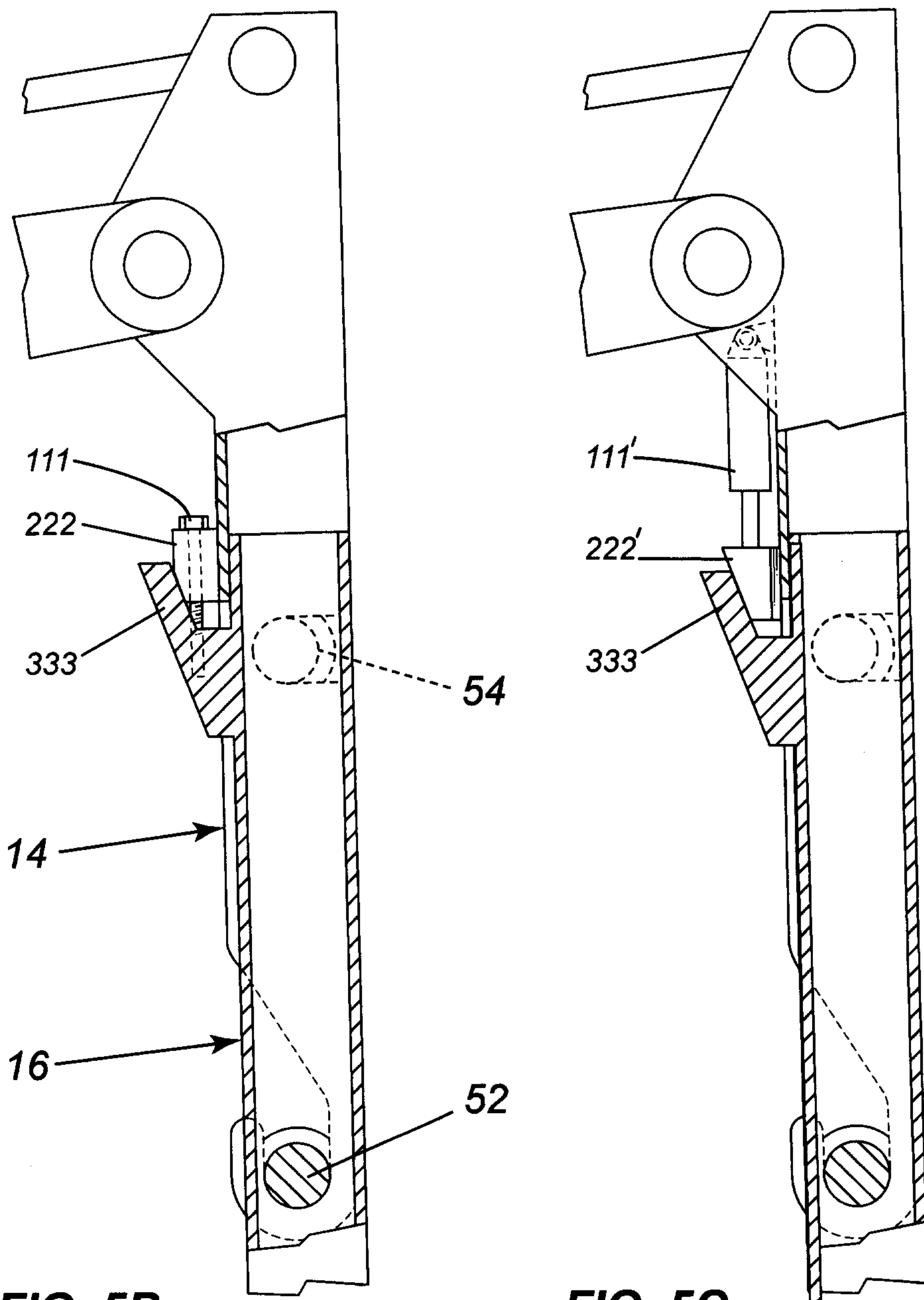

FIG. 5B

FIG. 5C

