

(12) **UK Patent Application** (19) **GB** (11) **2 160 919 A**

(43) Application published 2 Jan 1986

(21) Application No **8513585**  
(22) Date of filing **30 May 1985**  
(30) Priority data  
(31) **8414780** (32) **9 Jun 1984** (33) **GB**

(51) INT CL<sup>4</sup>  
**E01B 29/17**  
(52) Domestic classification  
**E1G 404 416**  
**B8A 4F2 4J 4JK**  
(56) Documents cited  
**None**  
(58) Field of search  
**E1G**  
**B8H**

(71) Applicant  
**Northern Engineering Industries plc (United Kingdom),  
NEI House, Regent Centre, Newcastle upon Tyne  
NE3 3SB**  
(72) Inventor  
**Michael Keddy**  
(74) Agent and/or Address for Service  
**John G Graham,  
Northern Engineering Industries plc, Group Patent  
Dept, c/o International Research & Development Co  
Limited, Fossway, Newcastle upon Tyne NE6 2YD**

(54) **Rail handling equipment**

(57) Rail handling equipment has a rail lifting and guide device 20 which has a support member 24 pivotally supporting gripper members 26 and lever members 28A, 28B. The lever member 28A, 28B are mounted such that they can move vertically relative to the support member 24. When the device 20 approaches a rail 58, the lever members 28A, 28B engage the surface upon which it is lying and the support member 24 continues to move downwardly relative to the lever members 28A, 28B to enable the gripper members 26 to be closed onto the head 60 of the rail 58. Once the rail 58 has been lifted clear of the surface, the lever members 28A, 28B can be closed to engage the flange 62 of the rail 58 via rollers 50, 52. The gripper members 26 can be then opened to allow the rail 58 to be moved longitudinally relative to the device 20. The support member can have rollers which straddle the head 60 of the rail 58 to prevent the rail tipping over during said longitudinal movement.

*Fig.2.*

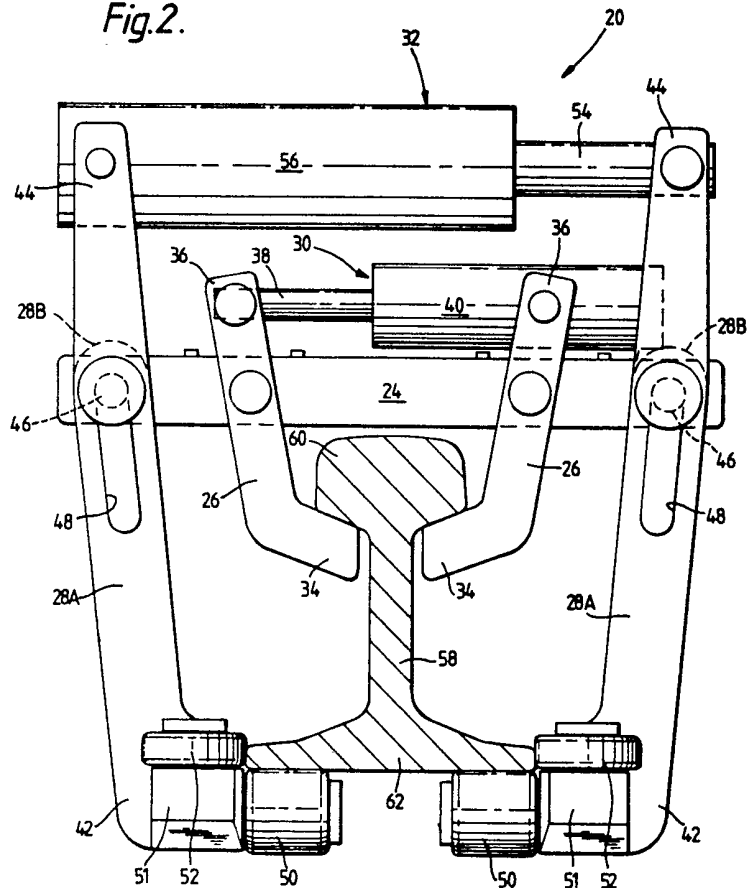

**GB 2 160 919 A**

Fig. 1.

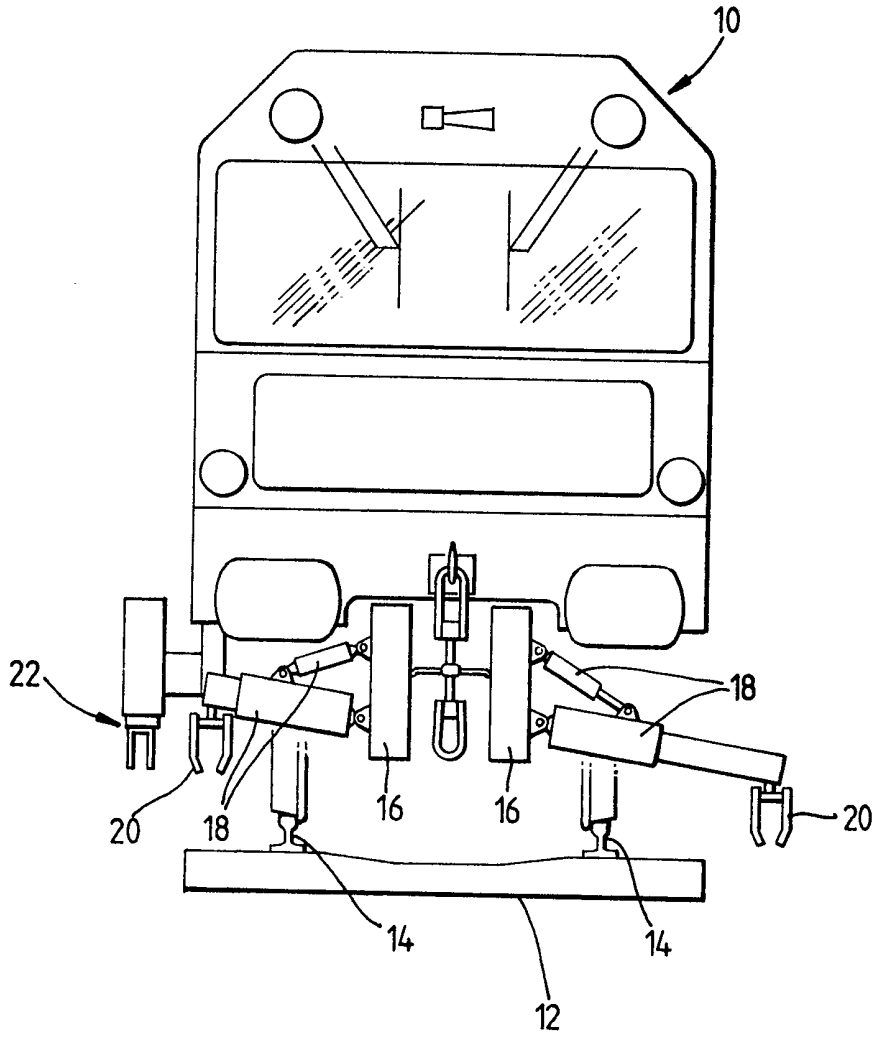
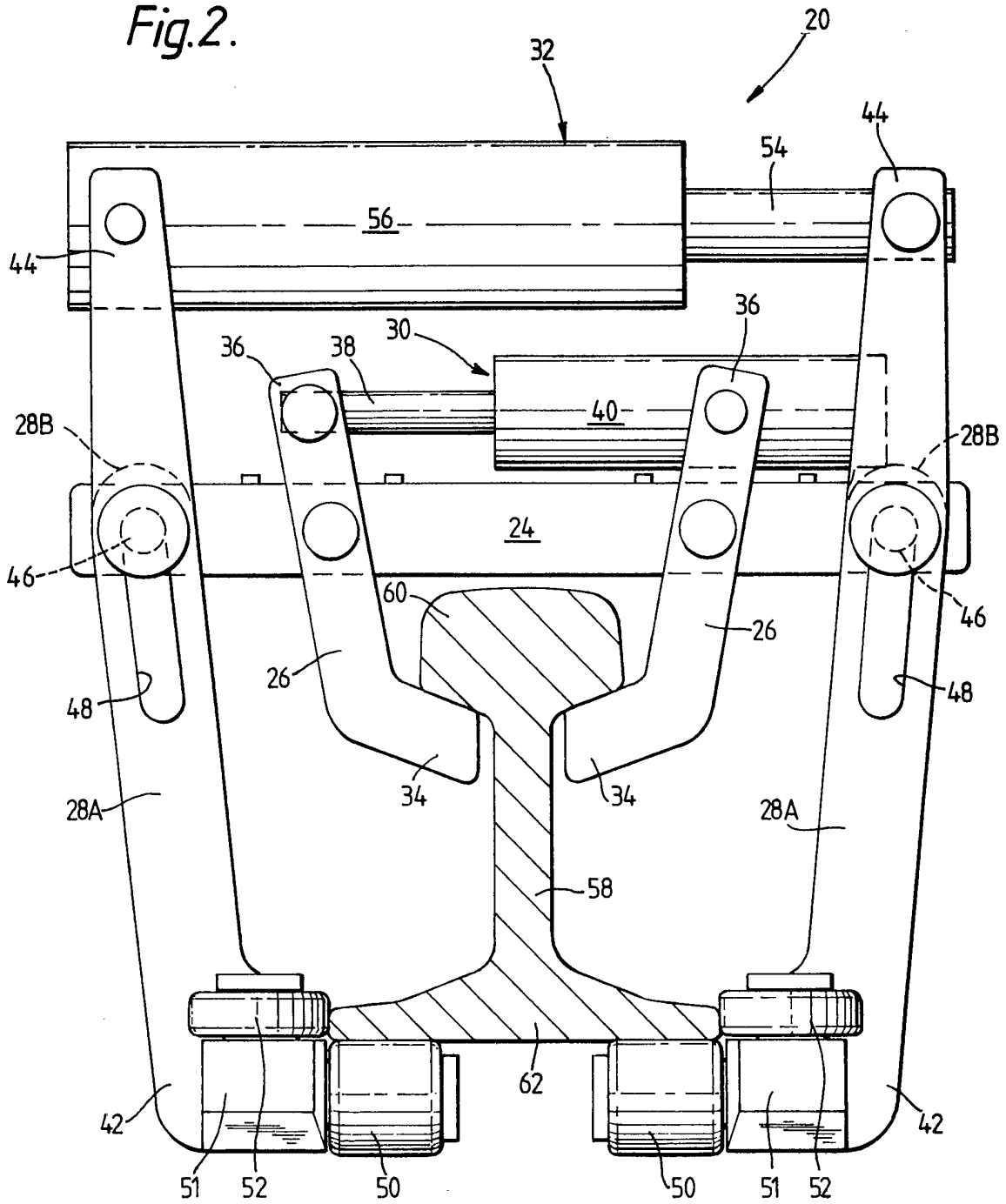

Fig. 2.



## SPECIFICATION

## Rail handling equipment

5 The invention relates to rail handling equipment.

10 In many railway track maintenance operations, it is often necessary to lift and guide a rail relatively to a railway vehicle whilst the vehicle is moved along the track. Typically, such operations include transferring rails from the inside to the outside of the track and vice versa and the loading and unloading of rails on to and off a rail handling train.

15 One prior proposal for rail handling equipment included a rail lifting and guide device having horizontally-mounted rollers for supporting a rail beneath the flange thereof and vertically-mounted rollers for laterally guiding the rail. In operation, the device is positioned relatively to a rail and operated to close the horizontally-mounted rollers about the head of the rail. The rail is then lifted, supports are then placed beneath the rail and the rail is then lowered onto the supports. The device is operated to open the rollers so that the device can be lowered relatively to the rail. The device is operated to locate the horizontally-mounted rollers beneath the flange of the rail, the vertically-mounted rollers being located on either side of the flange. The device is then raised to support the rail on the horizontally-mounted rollers.

20 The operation of the prior proposed device is time-consuming in that it involves two lifting sequences and it also involves the manual location of rail supports beneath the rail that is being handled.

25 It is an object of the present invention to provide rail handling equipment having a rail lifting and guide device which avoids those disadvantages.

30 According to the present invention, rail handling equipment comprises a support structure, a rail lifting and guide device and means for mounting the device on the structure for movement relative thereto, the device comprising a support member to which the mounting means is secured, at least two gripper members pivotally mounted on the support member so that the lower ends of the gripper members are locatable on either side of a rail and are engageable with the rail beneath the head thereof, at least two lever members pivotally mounted on the support member so that the lower ends of the lever members are locatable on either side of a rail, roller means mounted on the lower ends of the lever means engageable with the flange of the rail and first and second actuator means operable to open and close the gripper members and the lever members, respectively, the lever members being free to move substantially vertically relative to the support member whereby, during a rail handling operation,

35

40

45

50

55

60

65

70 when the lever members are in their open position, the support member, together with the gripper members, can continue to approach a rail support surface after downward movement of the lever members is arrested by the surface to grip and lift a rail from or deposit and release a rail onto the surface.

75 According to the invention also, a rail lifting and guide device as defined in the preceding paragraph.

80 Preferably, the first and second actuator means of the device each comprise a piston-and-cylinder unit attached between upper ends of the gripper members and the lever members, respectively.

85 Rail handling equipment will now be described to illustrate the invention by way of example only with reference to the accompanying drawings, in which:—

90 *Figure 1* is a schematic elevation on the front of a railway maintenance train; and

95 *Figure 2* is a schematic end elevation of a rail lifting and guiding device forming part of the train shown in Fig. 1, the device being in its closed position having lifted a rail.

100 One of the functions of the train 10 is to transfer lengths of rail, typically between 18 metres and 180 metres in length, from between the rails 14 of the track 12 to the outside of the track 12 and vice versa.

105 To achieve that function, the train 10 has a support structure 16 (see Fig. 1) on which are mounted hydraulic piston-and-cylinder units 18 from which depend rail lifting and guide device 20. One unit 18 is shown extended (right hand half of Fig. 1) and the other unit 18 is shown retracted (left hand half of Fig. 1).

110 The train 10 is provided with other rail guide devices on suitable outrigger means along its length, for example as indicated at 22.

115 The rail lifting and guide devices 20 (see Fig. 2) each have a support member 24 pivotally connected to the respective unit 18; two gripper members 26; two pairs of lever members 28A and 28B arranged one pair on each side of the two gripper members 26, and respective actuator means for opening and closing the gripper members 26 and the lever members 28 in the form of hydraulic piston-and-cylinder units 30 and 32.

120 The gripper members 26 are pivotally mounted on the support member 24 intermediate their ends 34, 36. The lower ends 34 of the members 26 are at an angle to the remainder of the length of the members 26 so that in the closed position of the members 36 the lower ends 34 engage a rail 58 beneath the head 60 thereof.

125 The upper ends 36 of the gripper members 26 are respectively pivotally connected to the piston rod and to the cylinder 40 of the unit 30.

130 The pair of the lever members 28A are

pivotally mounted on the support member 24 intermediate their ends 42, 44. The pivot pins 46 extend through slots 48 in the members 28A so that the members 28A are free to move vertically relative to the support member 24.

Similarly the other pair of levers 28B are pivotally mounted on the support member 24 by pivot pins (not shown) extending through corresponding slots in the members 28B.

The lower ends 42 of the levers 28A are integrally connected to adjacent lower ends of the levers 28B whereby the two pairs of levers 28A and 28B are simultaneously movable vertically relative to the support member 24 and are simultaneously openable or closable.

The lower ends 42 of the lever members 28A and the lower ends of the lever members 28B each have horizontally-mounted rollers 50 and on end flanges (referenced 51 in the case of levers 28A) vertically-mounted rollers 52 for engaging beneath and at the sides of the flange 62 of the rail 58, respectively, in the closed position of the members 28.

The upper ends 44 of the lever members 28A are respectively pivotally connected to the piston rod 54 and to the cylinder 56 of the unit 32.

The support member 24 supports two pairs of vertically-mounted rollers (not shown), one pair at each end of the device 20, such that the pairs of rollers straddle the head 60 of the rail 58 to prevent the rail 58 tipping over during longitudinal movement of the rail 58 relative to the device 20.

In operation, the train 10 is positioned adjacent to the end of a rail 58 to be handled. One of the units 18 is operated to locate the respective device 20 over the rail 58. In moving to that position, the downward movement of the lever members 28A and 28B is arrested by the ground. Consequently, the support member 24, and the gripper members 26, continue to move downwardly relative to the lever members 28A and 28B and the rail 58 to locate the gripper members 26 in the position in which they can grip the rail 58.

The unit 30 is then operated to close the gripper members 26 on the rail 58, following which the unit 18 is operated to lift the rail 58 clear of the ground, the lever members 28A and 28B are free to move downwardly relative to the support member 24. Once the lever members 28A and 28B are in their lower position, the unit 32 is operated to close the lever members 28A and 28B onto the rail 58 to locate the rollers 50 and 52 beneath and at the side of the flange 62 of the rail 58.

The unit 30 is then operated to open the gripper members 26 to release the rail 58 for longitudinal movement relative to the device 20 and the unit 18 is operated to position the

device 20 such that it will guide the rail 58 to its new position.

Forward movement of the train 10 causes the rail 58 to pass through the device 20. As the other guide devices, e.g. as at 22, approach the end of the rail 58, they are engaged with the rail 58 and positioned to guide the rail 58 to its new position. Continued forward movement of the train 10 relocates the rail 58 in its new position.

The unit 32 is operated at a relatively low pressure. Consequently, when longer rails are handled, the passage of the parts of the rail with welding flash thereon through the device causes the lever members 28A and 28B to open slightly to permit passage of the flash therethrough.

Once the train 10 reaches the other end of the rail 58, the other guide devices are disengaged from the rail 58, the unit 30 is operated to reclose the gripper members 26 onto the rail 58 and the unit 32 is operated to open the lever members 28A and 28B to disengage rollers 50 and 52 from the rail 58. The unit 18 is then operated to lower the end of the rail 58 to the ground, downward movement of the lever members 28A and 28B being arrested in a similar manner to that described above. The unit 30 is then operated to open the gripper members 26 to release the rail 58.

It will be appreciated that the train 10 can handle two rails simultaneously.

The device 20 described above allows the rail to be lifted in preparation for guidance in a single operation without the need for manual assistance in the operation.

It will be appreciated that the train 10 is intended to exemplify the invention only and rail handling equipment in accordance with the invention can take other forms including other types of rail handling or maintenance trains or vehicles.

Other modifications are possible within the scope of the invention. For example, the lever members could be connected to the support member by means of a link pivoted on the support member and the respective lever member, the units 30 and 32 could be connected to the gripper members and lever members through toggle mechanisms.

## CLAIMS

1. Rail handling equipment comprising a support structure, a rail lifting and guide device and means for mounting the device on the structure for movement relative thereto, the device comprising a support member to which the mounting means is secured, at least two gripper members pivotally mounted on the support member so that the lower ends of the gripper members are locatable on either side of a rail and are engageable with the rail beneath the head thereof, at least two lever members pivotally mounted on the support

- member so that the lower ends of the lever members are locatable on either side of a rail, roller means mounted on the lower ends of the lever means and engageable with the
- 5 flange of the rail and first and second actuator means operable to open and close the gripper members and the lever members, respectively, the lever members being free to move substantially vertically relative to the support
- 10 member whereby, during a rail handling operation, when the lever members are in their open position, the support member, together with the gripper members, can continue to approach a rail support surface after downward movement of the lever members is arrested by the surface to grip and lift a rail from or deposit and release a rail onto the surface.
2. Rail handling equipment according to
- 20 claim 1, in which the first and second actuator means of the device each comprise a piston-and-cylinder unit.
3. Rail handling equipment according to
- 25 claim 1 or claim 2, in which the gripper members and the lever members are mounted on the support member intermediate their ends, the first and second actuator means being connected between the upper ends of the gripper members and the lever members,
- 30 respectively.
4. Rail handling equipment according to any preceding claim, in which the lever members each have a slot extending generally parallel to the length of the lever member, a
- 35 pivot pin secured to the support member extending through the slot.
5. Rail handling equipment according to any preceding claim, in which the device comprises a second pair of lever members
- 40 located on the side of the gripper members remote from the first pair of lever members, the lower ends of the second pair of lever members being integrally connected to respective adjacent lower ends of the first pair
- 45 of lever members whereby the pairs of lever members are movable simultaneously with one another.
6. Rail handling equipment according to any preceding claim, in which the support
- 50 member supports at least one pair of vertically-mounted rollers such that the pair of rollers straddle the head of a rail to prevent the rail tipping over during longitudinal movement of the rail relative to the device.
- 55 7. Rail handling equipment according to claim 1, substantially as hereinbefore described with reference to the accompanying drawings.
8. A rail lifting and guide device as
- 60 claimed in any preceding claim.