

75-4

T. B. & J. C. PELL.
OVERALLS.
APPLICATION FILED MAY 14, 1909.

965,596.

Patented July 26, 1910.

3 SHEETS—SHEET 1.

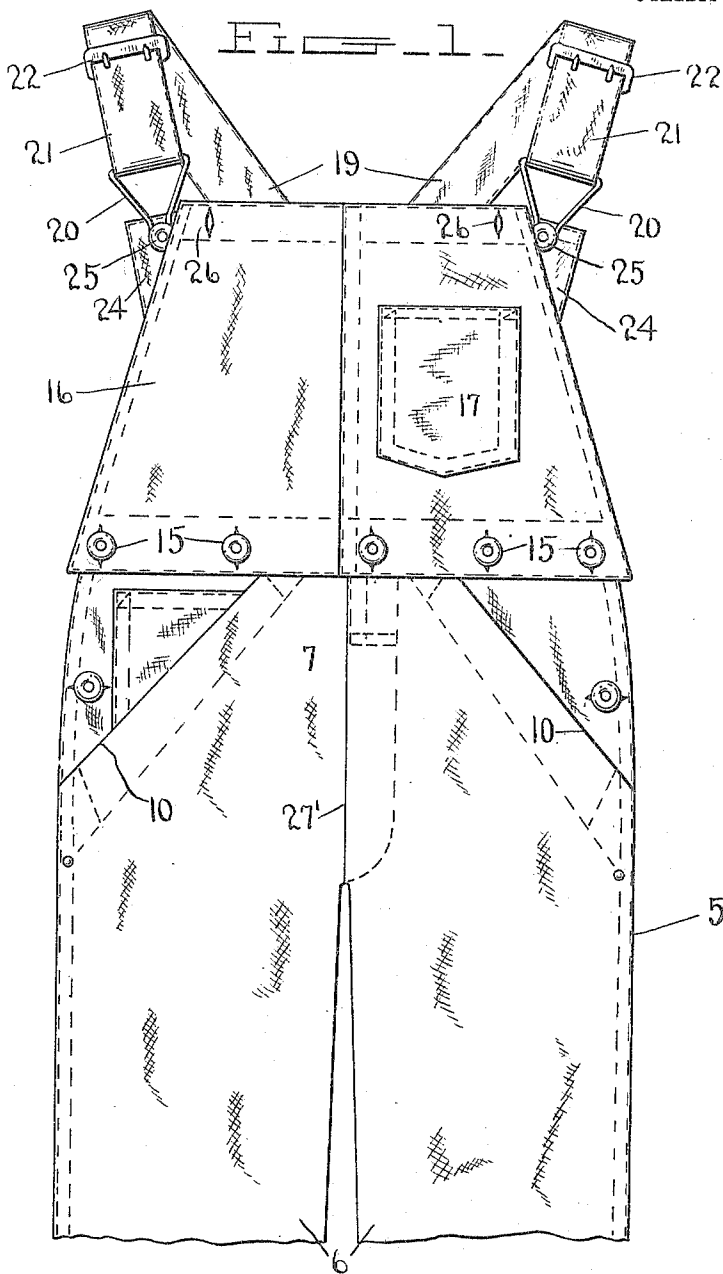

Witnesses

L. B. Jamieson
W. O. Parker

Tom B. Pell
Joseph C. Pell

Inventors

By

Charles Chandler

Attorneys

965,596.

Patented July 26, 1910.

3 SHEETS—SHEET 2.

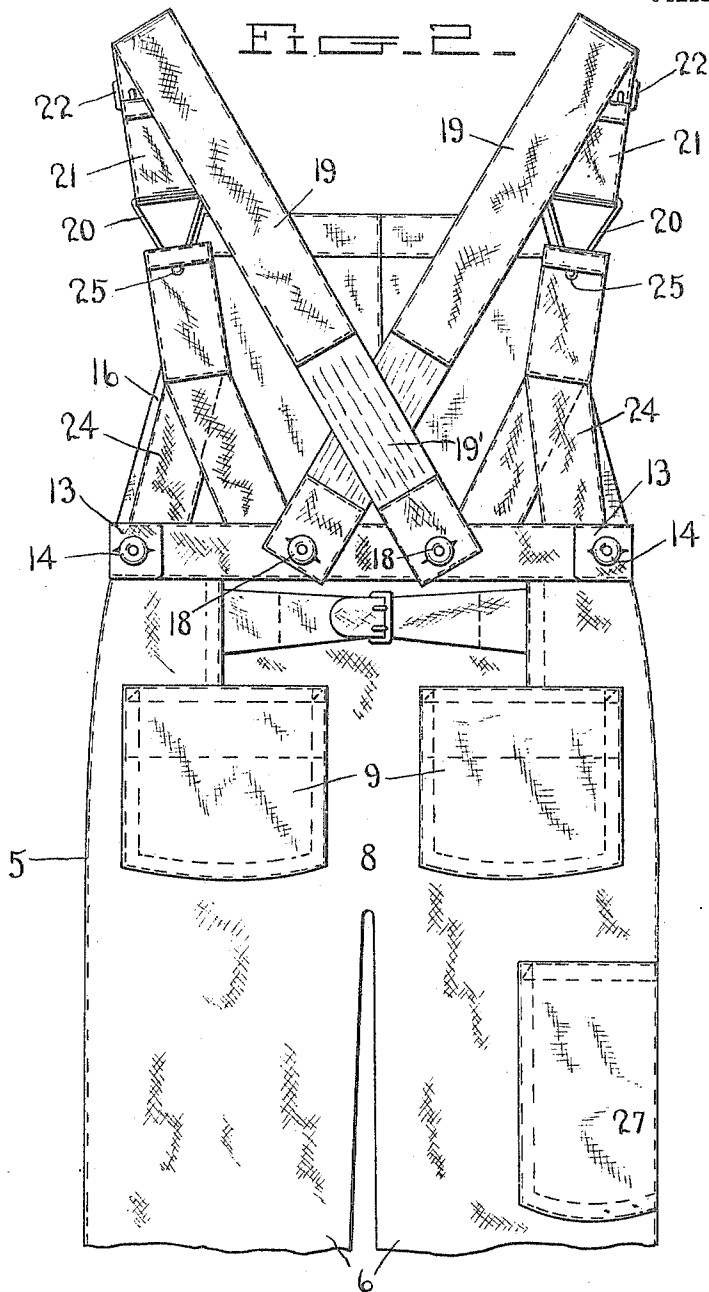

Inventors

Witnesses

L. B. James
H. O. Sawden

Tom B. Pell
Joseph C. Pell &

By

Charles Chandler

Attorneys

965,596.

Patented July 26, 1910.

3 SHEETS—SHEET 3.

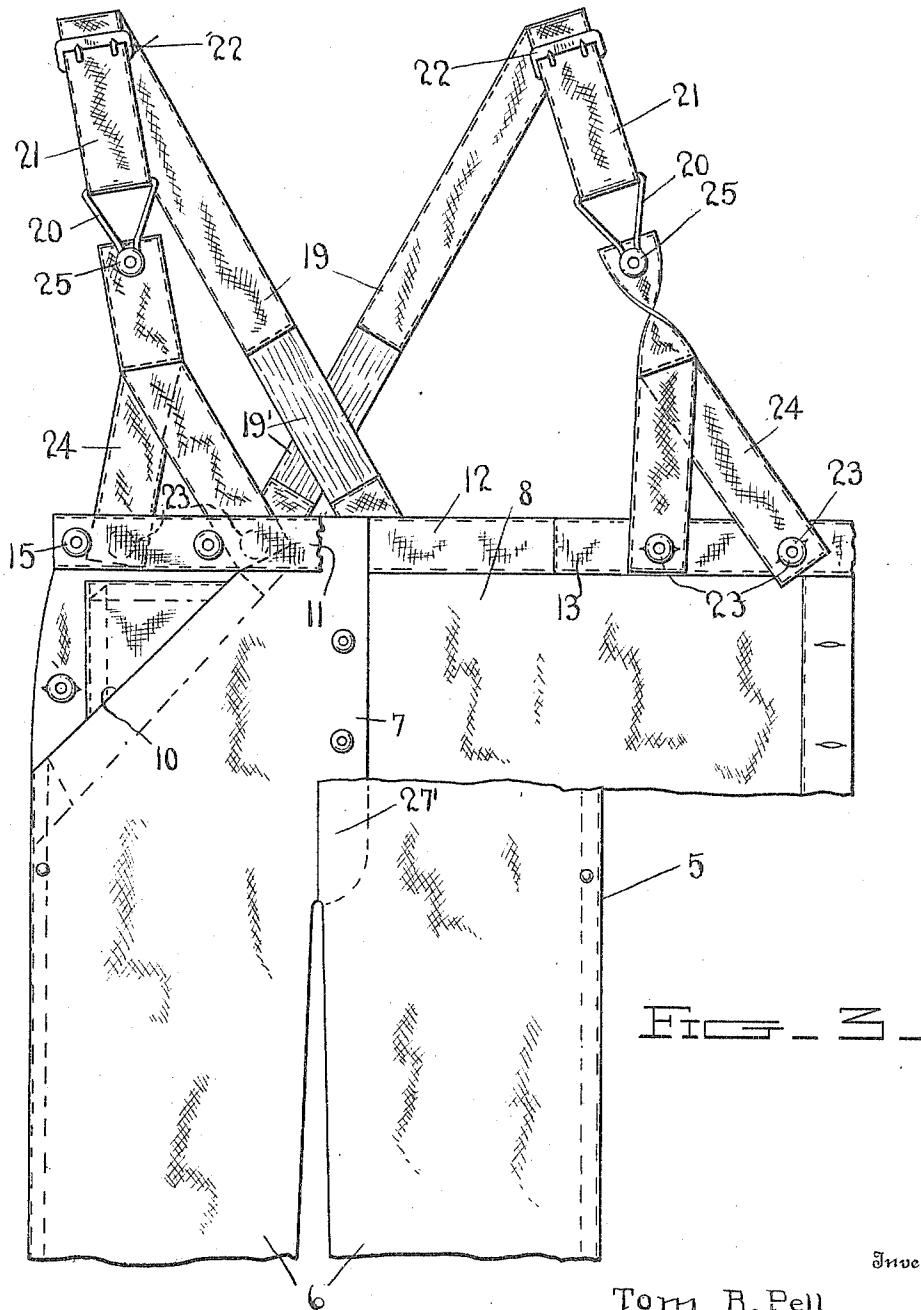

FIG. 3

Inventors

Tom B. Pell
Joseph C. Pell &

Witnesses

L. B. James
W. O. Parker

By

[Signature] *[Signature]*

Attorney S

UNITED STATES PATENT OFFICE.

TOM BLINCOE PELL AND JOSEPH CURTIS PELL, OF LEWISPORT, KENTUCKY.

OVERALLS.

965,596.

Specification of Letters Patent. Patented July 26, 1910.

Application filed May 14, 1909. Serial No. 495,866.

To all whom it may concern:

Be it known that we, TOM B. PELL and JOSEPH C. PELL, citizens of the United States, residing at Lewisport, in the county of Hancock, State of Kentucky, have invented certain new and useful Improvements in Overalls; and we do hereby declare the following to be a full, clear, and exact description of the invention, such as will enable others skilled in the art to which it appertains to make and use the same.

The invention relates to overalls and more particularly to the class of overalls having suspender and apron attachments, for use by laborers such as carpenters, bricklayers or the like.

The primary object of the invention is the provision of a pair of overalls in which an apron section is connected thereto so that it may be used with the same or removed at the will of the wearer, and suspender means detachably connected to the overalls and to the apron section whereby the said overalls may be worn in the ordinary manner.

Another object of the invention is to have a shirt protector such as an apron section accompanying each pair of overalls purchased, and should the purchaser or wearer find that he does not need the apron section it may be readily detached so that the overalls may be worn in the usual manner.

A further object of the invention is the provision of a pair of overalls in which the shirt of a wearer may be protected by means of an apron section or protector which may be readily and easily detachably connected to the supporters and the belt of the overalls, and which protector may hang loose so as to be worn as an apron when required.

With these and other objects in view, the invention consists in the construction, combination and arrangement of parts, as will be hereinafter more fully described in detail, illustrated in the accompanying drawings, which disclose the preferred form of embodiment of the invention, to enable those skilled in the art to practice the same, and as set forth in the claim hereunto appended.

In the drawings:—Figure 1 is a front elevation of a pair of overalls constructed in accordance with the invention. Fig. 2 is a rear elevation thereof. Fig. 3 is a front elevation of a pair of overalls with the front

broken away and distended to show in detail the manner of connecting the suspenders to the front of the overalls.

Similar reference characters indicate corresponding parts throughout the several views in the drawings.

In the drawings, the numeral 5 designates generally overalls comprising leg portions 6, with front and back waist sections 7 and 8, the latter having stitched thereto hip pockets 9, while the front waist section 7, is provided with the usual side pockets 10. Secured to the upper edge of the front and back sections 7 and 8 is a belt or waist band, the latter formed of a front section 11, which extends across and throughout the length of the upper edge of the front body section 7, and a back section 12, coextensive with the upper edge of the back body section and terminates in terminal tabs 13, suitably buttonholed to engage buttons 14, carried near opposite terminals of the front section of the waist band, to detachably unite the front and back body sections of the overalls where they are separated by suitable openings or slits at opposite sides of the latter to permit the lowering of the front or back body section at the will of the wearer.

Connected exteriorly to the front section 11, of the waist band or belt are a row of spaced buttons 15, for the detachable connection of a protector forming an apron section 16, the latter being provided at its lower edge with the usual buttonholes for the connection thereof with the buttons 15, of the overalls. Stitched to the apron section 16, on its front face is a pocket 17, which may be used for any purpose desired.

Connected exteriorly to the rear section 12, of the waist band are a pair of buttons 18, to which are detachably secured the rear terminals of suspenders comprising shoulder straps 19, which latter are crossed as at 19' and passed upwardly and over the shoulders of a person, and have connected at their front extremities substantially V-shaped loop members 20, which latter are adjustably supported by loop terminals 21, carrying buckles 22, which latter permit the adjustment of the shoulder strap to the wearer.

To the front section 11, of the waist band are connected at its inner face buttons 23, to

which are connected front straps 24, which latter have secured thereto at their upper terminals buttons 25, for the connection of the loop members 20, of the shoulder straps 5 19 therewith. The apron section 16, at its upper edge is formed with buttonholes 26, to engage the buttons 25, so as to hold the apron 16, in position for protecting the shirt of the wearer.

10 One leg section has stitched thereto a rule pocket 27, which is of the ordinary form. The overalls 5, in the front body section 7, thereof are provided with the usual fly 27', for the convenience of the wearer.

15 It is clearly obvious that the apron section 16, may be readily detached from the overalls 5, when desired. It is also to be pointed out that the suspenders may be permanently connected to the waist band of 20 the overalls if deemed desirable.

The apron where it attaches to the waist-band may be fastened either by buttons, in the ordinary manner, by hooks and eyes, by

the snap button or in any other manner as best suits the trade. 25

What is claimed is:—

The combination with overalls, of shoulder straps composed of separable front and back sections, means detachably connecting said sections, means connecting the straps to 30 the front and rear of the overalls, and an apron of a length corresponding to the front sections of the shoulder straps carried by the overalls and detachably engaging the means connecting the said sections and also 35 detachably engaging the waist band of the overalls whereby the apron may be entirely removed from the latter.

In testimony whereof, we affix our signatures, in presence of two witnesses.

TOM BLINCOE PELL.
JOSEPH CURTIS PELL.

Witnesses:

M. T. MILLER,
S. R. BRATTAN.