

J. J. HARDENBROOK.
HEATING-DRUM.

No. 171,378.

Patented Dec. 21, 1875.

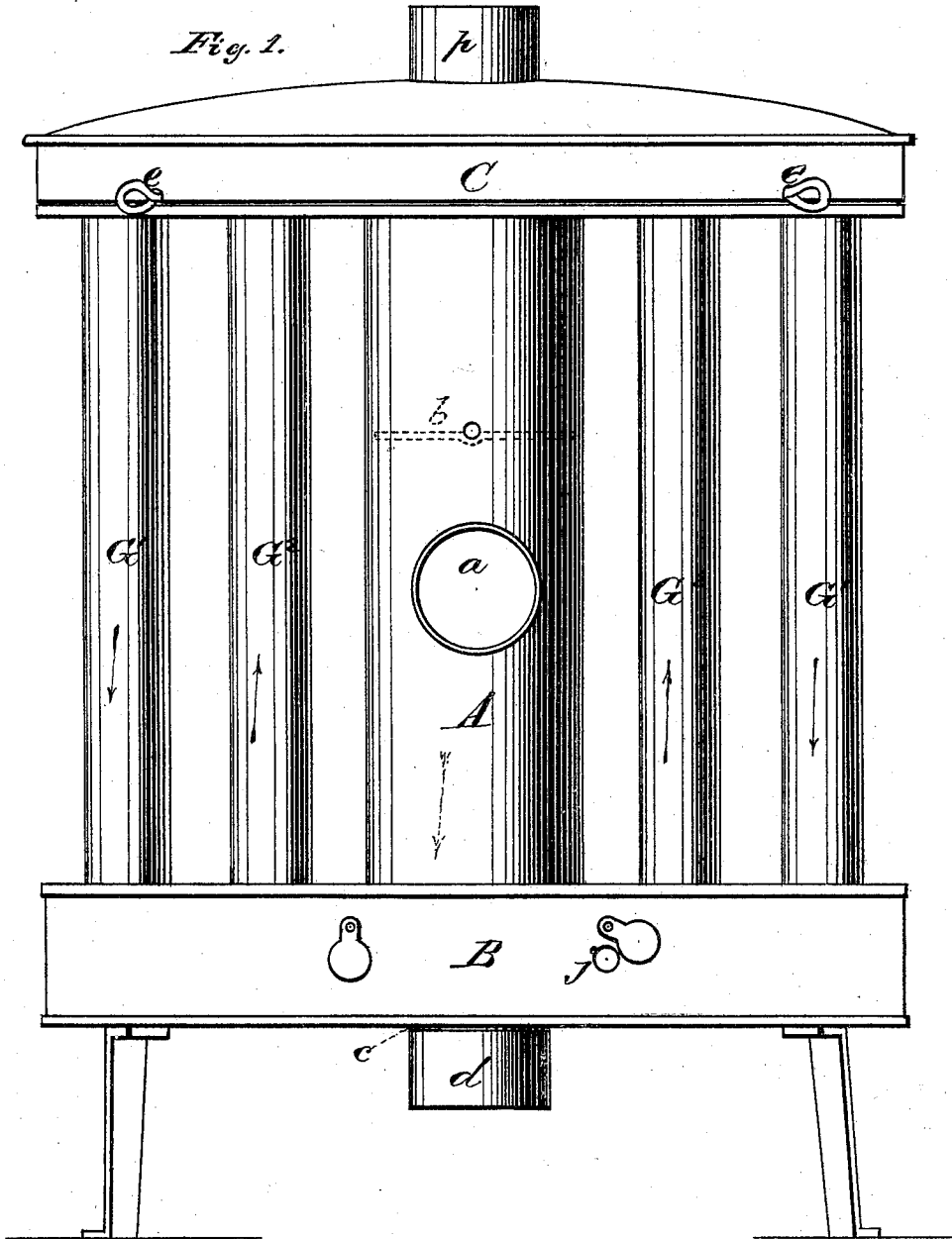

WITNESSES
Robert Everett
Bryan H. Morse

INVENTOR
John J. Hardenbrook
Chipman & Co.
ATTORNEYS

J. J. HARDENBROOK.
HEATING-DRUM.

No. 171,378.

Patented Dec. 21, 1875.

Fig. 2

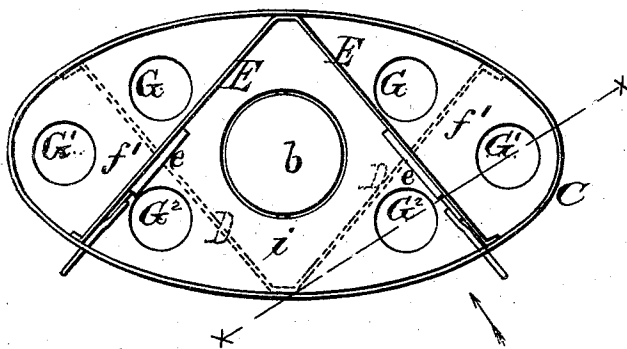
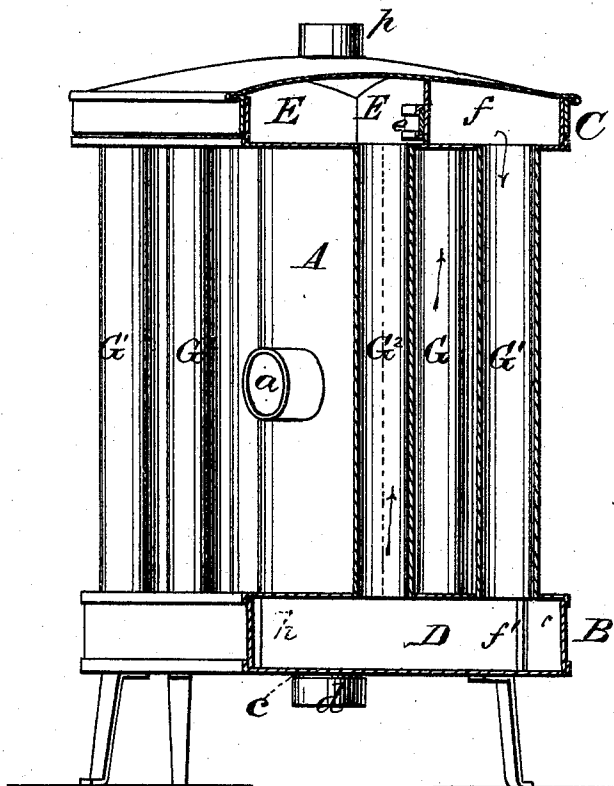

Fig. 3



WITNESSES

Robert Everett
Bryan H. Morse

INVENTOR

John J. Hardenbrook
Chipman & Farnum Co.
ATTORNEYS

UNITED STATES PATENT OFFICE.

JOHN J. HARDENBROOK, OF COLUMBUS GROVE, OHIO.

IMPROVEMENT IN HEATING-DRUMS.

Specification forming part of Letters Patent No. **171,378**, dated December 21, 1875; application filed November 20, 1875.

To all whom it may concern:

Be it known that I, JOHN J. HARDENBROOK, of Columbus Grove, in the county of Putnam and State of Ohio, have invented a new and valuable Improvement in Heaters; and I do hereby declare that the following is a full, clear, and exact description of the construction and operation of the same, reference being had to the annexed drawings, making a part of this specification, and to the letters and figures of reference marked thereon.

Figure 1 of the drawings is a representation of a front view of my heater, and Fig. 2 is a top-plan view with top cap removed. Fig. 3 is a perspective view, part diagonally, vertically sectional.

This invention has relation to heaters through which the products of combustion from a cook or other stove are conducted on their way to the chimney, for the purpose of warming apartments other than that in which the stove is located.

The nature of my invention consists in a radiator or heater having a central drum, which receives the products of combustion, and which communicates with a heating base and cap, in combination with smaller drums or flues, and partitions having valves in them, which latter are so arranged that the heat of the drum can be regulated as may be desired. The invention also consists in the combination and novel arrangement of a damper and the central radiating-drum in a heater, which I shall hereinafter describe.

In the annexed drawings, A designates a vertical cylinder or drum, which communicates with a hollow base, B, and also with a hollow cap, C. The drum A has an opening, *a*, for the entrance of the heated products of combustion from a stove, and directly above this opening *a* is a damper, *b*, which, when it is shut, will direct all of the products of combustion down into the base B; but when it is opened all of the products will rise directly and pass off through a pipe, *p*, leading out of the top of the hollow cap C. Directly below the drum A is an opening surrounded by a collar, *c*, to which the pipe leading from a stove may be connected, instead of being connected to the collar surrounding the opening through the side of drum A. A cap, *d*, is

used for closing either one or the other of the said openings. D D designate vertical plates, which are applied inside of the base B, and arranged in the form of the letter V, for a purpose hereinafter explained, and E E designate vertical plates, which are arranged in the cap C in a reverse order to the plates D D, as indicated in full lines, Fig. 2. The plates E E are provided with damper-slides *ee*. On each side of the drum A are three vertical pipes, G G¹ G², which extend from the base B to the cap C. The two pipes G G¹, on each side of the drum A, communicate with a chamber, *f*, in the cap C, and with a chamber, *f'*, in the hollow base B, and the pipe G², on each side of said drum, communicates with a chamber, *h*, in the base A, and with a chamber, *i*, in the cap. The said chambers are formed in the base and cap by means of the V-shaped partitions above described, and shown in Fig. 2.

The operation of my improved heater is as follows: The products of combustion enter the drum A below the damper *b*, and when this damper is open they ascend directly and pass off into the chimney through the pipe *p*. When the damper *b* is shut the products of combustion descend into the chamber *h*; thence they ascend into chambers *f'* through pipes G and G¹; thence they descend through pipes G¹ and G¹ into chambers *f* and *f*, and from these chambers the products ascend through pipes G² and G² into chamber *i*, from which they finally escape through the pipe *p*. If the dampers *ee* are opened the products of combustion will escape directly into chamber *i* from chambers *f'* *f'*, and will not circulate through pipes G¹ G². Openings *j* are made through the base B, covered by valves, for allowing this base to be cleaned out when necessary. The cover of the cap C is removable, for the purpose of obtaining access to the interior of this cap, and also to the several pipes, when it is desired to clean out the same. If desired, a damper may be applied in the base of the heater, and any desired number of side pipes may be used.

What I claim as new, and desire to secure by Letters Patent, is—

1. In combination with the drum A, having a damper, *b*, and opening *a*, the base B and

cap C, having V-shaped partitions and damp-er-slides *e* in them, and communicating with each other by means of pipes G G¹ G², substantially as and for the purposes described.

2. The vertical V-shaped plates D E, arranged in reversed order in the base B and cap C, in combination with the vertical pipes G C¹ G², operating substantially as described.

In testimony that I claim the above I have hereunto subscribed my name in the presence of two witnesses.

JOHN J. HARDENBROOK.

Witnesses:

CHARLES HOLLIS,
S. SANDERS.