

Dec. 14, 1943.

J. J. CROSS

2,336,927

CODE SIGNAL DISPLAY APPARATUS

Filed Jan. 1, 1943

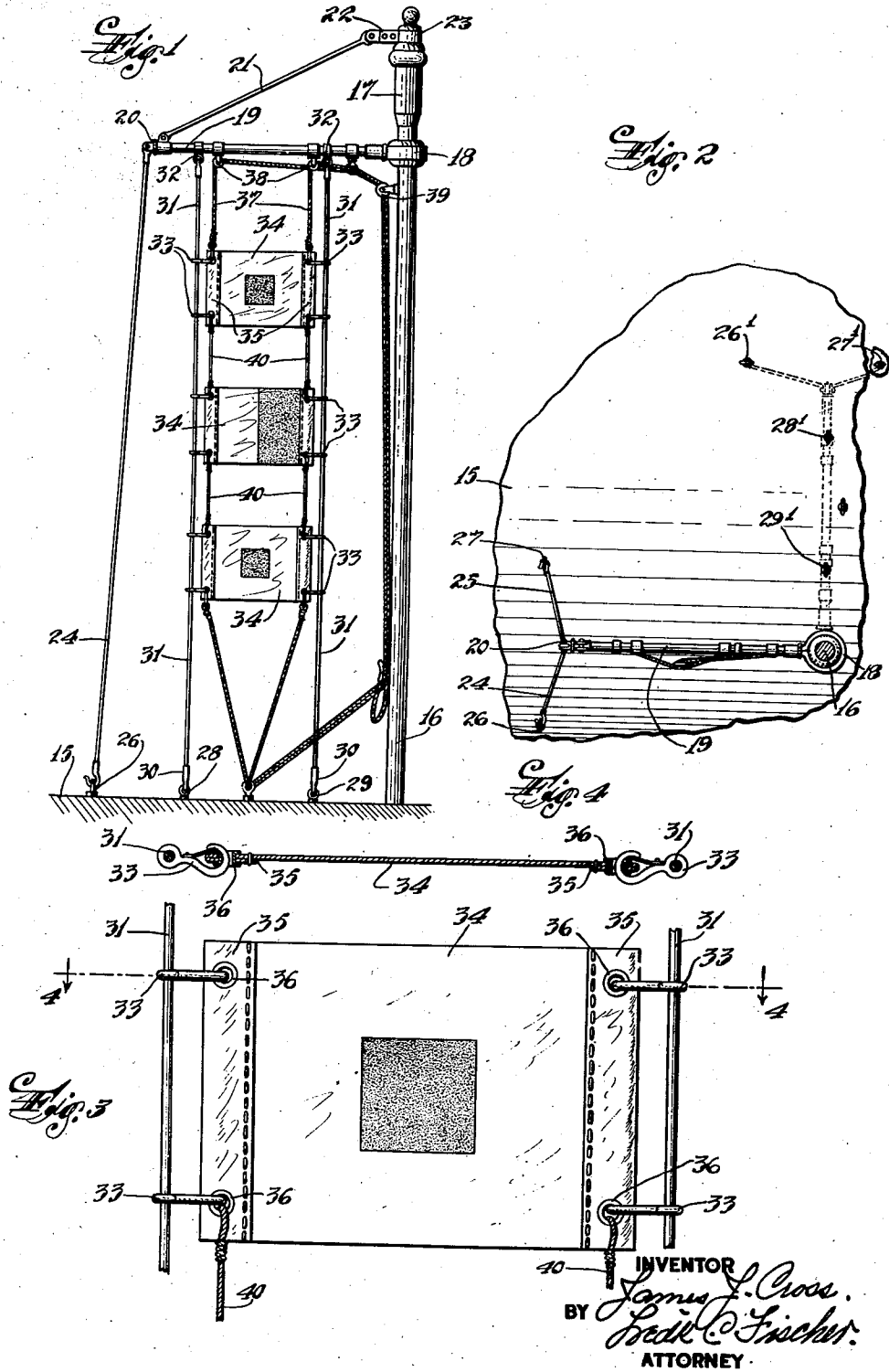

INVENTOR
James J. Cross
BY *Frank C. Fischer*
ATTORNEY

UNITED STATES PATENT OFFICE

2,336,927

CODE SIGNAL DISPLAY APPARATUS

James J. Cross, Elizabeth, N. J.

Application January 1, 1943, Serial No. 471,222

8 Claims. (Cl. 116—173)

This invention relates to visible signal display apparatus and more particularly to such as are adapted to exhibit flags bearing codes.

The necessity of showing such devices has long been recognized; in fact, is embodied in international code signals.

They are usually displayed upon buntings and flags of different shapes, made of textile fabric, which, upon subjection to strong winds or gales, are rapidly destroyed; further, if supported by a pole, are prone to wrap themselves therearound thereby becoming undecipherable.

It is, therefore, an object of the invention to provide signal flags made of strong material, reinforced at their ends to withstand wind and secured at each of their four corners in a substantial manner.

A further feature is in the provision of flag supports which effectively maintain the flags, at all times, fully exposed and to which they may be attached or detached easily and quickly.

Another purpose is to provide an upright support that can be adjusted into different radial positions whereby the flags can be seen from different locations.

These and other advantageous objects are accomplished by the novel and practical construction, combination and arrangement of parts hereinafter described and illustrated in the accompanying drawing constituting a graphical component of this disclosure, and in which:

Fig. 1 is a side elevational view of a complete embodiment of the invention showing its use,

Fig. 2 is a plan view showing the device in full lines and in another position by broken lines,

Fig. 3 is a front view of one of the flags, drawn to an enlarged scale to show the construction, and

Fig. 4 is a sectional view taken on line 4—4 of Fig. 3.

Referring in detail to the several views, the numeral 15 designates in general a raised platform, such for instance as the deck of a ship, in which is rigidly set an upright standard 16 having at its upper end an enlarged terminal 17.

A collar 18 is rotatably mounted on the standard, below the enlargement, the collar being provided with a rigid arm or spar 19 extending at a right angle.

On the outer portion of the arm 19 is a T-shaped fitting 20, its raised central member engaged with a strut 21 having its opposite end engaged with a clevis 22 reaching outwardly from a band 23 suited to rotate on the upright above the enlargement 17.

Fixed to the extreme outer end of the arm 19 are two divergent guys 24—25, which may be rods, ropes or wires, tensioned and attached at their lower ends respectively to eyes 26—27, set in the deck 15. If the display is to be made at a right angle to that shown, the guys will be connected to eyes 26'—27' as indicated in Fig. 2. Other pairs of eyes 28—29 and 28'—29', arranged at suitable distances apart, and from the standard 16, receive the lower ends of tensional elements 30, connecting a pair of spaced stays or guide rods 31, attached at their upper ends to lugs formed with rings 32 carried by the arm 19.

These stays 31 may be rigid or flexible, as preferred, and act to receive pairs of snap hooks 33 in a manner to admit them to be slidably adjusted therealong at the will of an operator.

As shown in Fig. 1, three code signal flags are indicated, but any number can be displayed.

Each flag 34 is preferably composed of an exceedingly strong woven fabric, bearing on one or both sides such insignia as is desired to appear; they are ordinarily elongated rectangles and usually similar in size.

The ends of the material is turned over in the manner of a wide hem 35, secured by stitching to the face of the fabric, providing a most effective reinforcement.

At each of the four corners of the flag are set grommets 36, passing through the flap reinforcements in a manner to further strengthen the flag, and to receive the hook ends of the snap hooks 33, retaining the flag equally distanced between the guide rods 31.

The grommets in the corners of the upper flag are also adapted to receive the ends of a pair of cords 37 trained over pulleys 38 supported on the arm 19, and guided by other pulleys 39 on the standard, to extend into a position convenient for operation.

The foregoing applies to the uppermost flag, to which the others are connected in desired spaced, sequential relation by lanyards or the like 40 engaging in the adjacent grommets at each end of the flags.

From the foregoing it will be apparent that a superior type of flag has been disclosed made of strong material reinforced at its ends to withstand wind and secured at each of its four corners, together with a novel and highly practical manner of mounting.

The flags may be readily removed and others substituted in any easy, safe and rapid manner, and they cannot wrap around the pole or stand-

ard, but are invariably disposed to full view in a taut condition.

By reason of changing the angle of the display, relative to the axis of the standard, the flags will be visible to a greater extent than has hitherto been common.

Although the foregoing is broadly descriptive of the best known embodiment of the invention, it is to be understood as suggestive, rather than restrictive, and that modifications may be made within the scope and tenor of the subjoined claims.

Having thus described my invention, what I claim as new and desire to secure by Letters Patent is:

1. An apparatus for displaying flags comprising a base, an upright pole fixed thereon, an arm rotatably mounted on the upper portion of said pole, means to retain said arm horizontally, means to secure said arm in different radial positions relative to said pole, a pair of parallel upright guides extended between said arm and base, a plurality of flags having reenforced ends, grommets fixed in the corners of each flag, means to maintain said flags in spaced tandem relation, and snap fasteners slidable on said guides to removably engage in said grommets.

2. In a display apparatus for signal flags, a base, an upright standard, an arm rotatably mounted on the upper end thereof, guys extending in divergent transverse directions from the free end of said arm to said base, a pair of guides arranged in spaced parallel relation between said arm and base, and one or more flags detachably engaged at each of their four corners with said guides.

3. In combination with an upright pole mounted on a platform, a horizontal arm rotatably engaged on the upper portion of said pole, a guy member extending between the top of said pole and outer end of said arm, a pair of stress members secured to the outer end of the arm and divergently inclined at right angles to the arm, eyes fixed in said platform to which the lower ends of said stress members are secured, a second set of eyes on said platform for the stress members when said arm is in another radial position with reference to said pole, guide elements attached in spaced parallel relation to said arm, means to secure the lower ends of said guide elements to said platform in the vertical plane of the arm, snap hooks slidable on said guide elements, one or more signal flags engageable at their corners by said snap hooks, a pair of sheaves supported by said arm, and ropes connected with the upper corners of the topmost flag trained over said sheaves to extend to said plat-

form whereby the flag may be manually raised and lowered.

4. In combination with a platform having an arm turnably supported and positioned thereabove and having means to retain said arm in a predetermined radial position, a series of signal flags having grommets in each of their four corners, flexible spacing means connecting said flags one above another, a pair of upright guide members fixed at their respective ends to said arm and platform, snap hooks slidable on said members removably engageable with said grommets, and means for raising and lowering said flags operable from said platform.

5. A code signal apparatus for the display of a series of code signal flags, said apparatus comprising a standard adapted to be mounted on a base and an arm on said standard, a pair of upright guide members adapted to be fixed to said arm and to be secured to said base, fasteners slidable on said members and adapted to engage the signal flags to be displayed to slidably position the flags on the upright guide members, and supporting means carried by said arm and engaging said flags to raise and lower said flags manually.

6. A code signal apparatus for the display of a code signal flag, said apparatus comprising a standard adapted to be mounted on a base and an arm on said standard, a pair of upright guide members adapted to be fixed to said arm and to be secured to said base, fasteners slidable on said members and adapted to engage the signal flag to be displayed to slidably position the flag on the upright guide members, and means carried by said arm to raise and lower said flag manually.

7. A code signal apparatus for the display of a series of code signal flags, said apparatus comprising a standard adapted to be mounted on a base and an arm on said standard, a pair of upright guide members adapted to be fixed to said arm and to be secured to said base in spaced, parallel relation, fasteners slidable on said members and adapted to engage the signal flags to be displayed to slidably position the flags on the upright guide members, and means carried by said arm to raise and lower said flags manually.

8. In a display apparatus for signal flags, an upright standard adapted to be secured to a base, an arm rotatably mounted on the upper end of the standard, guys adapted to be secured to the free end of said arm and to the base and flag guides arranged in parallel relation on said arm and base, perpendicular to said arm and base.

JAMES J. CROSS.